

BLACKJACK KITCHEN TABLE KIT

NEED HELP OR ADVICE PUTTING THIS KIT TOGETHER? MISSING PIECES?
EMAIL US AT [SUPPORT@PIPE-DECOR.COM](mailto:support@pipe-decor.com) FOR ANY QUESTIONS

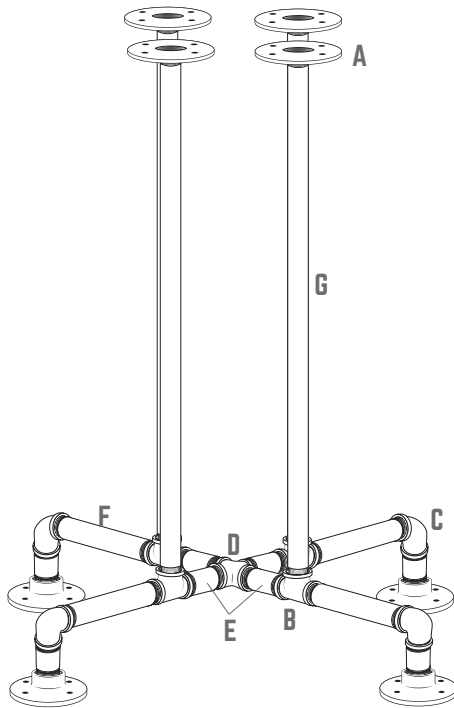

PART	DESCRIPTION	QTY
A	1/2" FLANGE	8
B	REDUCING TEE	4
C	3/4" 90° ELBOW	4
D	3/4" CROSS	1
E	3" PIPE	8
F	10" PIPE	4
G	24" PIPE	4
H	SCREWS	16



HOW TO PREVENT PIPE CORROSION

PIPE DECOR industrial-grade black pipes and fittings are coated with a rust-preventive oil during manufacturing. For best results, **SEAL THE PIPES TO AVOID ANY RUSTING** after cleaning the kit.

CLEAN AND SEAL INSTRUCTIONS:

- CLEAN:** Recommended supplies: regular degreasing dish soap, washcloths, gloves (optional)
1. Wash your pipes and fittings with warm water and dish soap until the oil is completely removed.
 2. Wipe the pipes with a dry washcloth and wait until the pipes are completely dry.

IMPORTANT: THE PIPES MUST BE COMPLETELY DRY BEFORE YOU START THE SEALING PROCESS.

SEAL: **IF USING POLYURETHANE SPRAY:** Spray each dry pipe and fitting with a polyurethane matte or satin finishing spray and let it dry before assembling the kit.

IF USING FINISHING WAX: Coat each dry pipe with a finishing wax. Wait for 20 minutes, then polish the pipe with a dry washcloth by wiping them down. Faster wiping will result in a shinier finish.

PIPE DECOR®

BLACKJACK KITCHEN TABLE KIT

STEP 1:

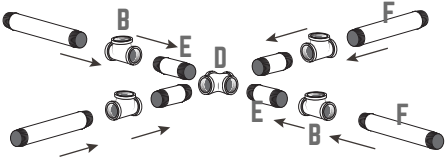

STEP 2:

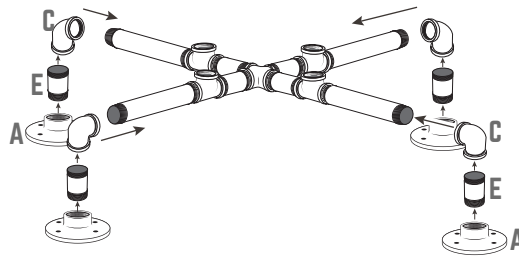

STEP 3:

