

## 90° ELBOW HOOK WITH ROUND FLANGE - 2PK

NEED HELP OR ADVICE PUTTING THIS KIT TOGETHER? MISSING PIECES?  
EMAIL US AT SUPPORT@PIPE-DECOR.COM FOR ANY QUESTIONS

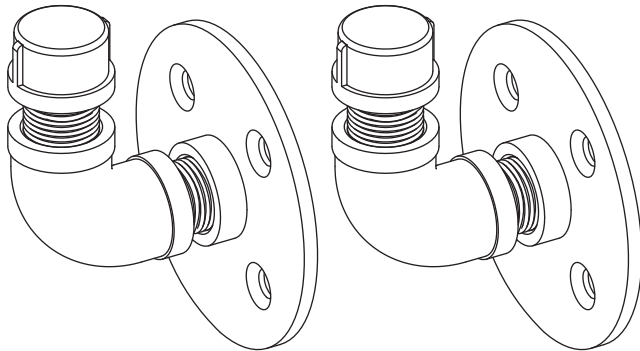

PART	DESCRIPTION	QTY
A	1/2" FLANGE	2
B	90° ELBOW	2
C	1-1/2" NIPPLE	2
D	CLOSE NIPPLE	2
E	1/2" CAP	2
F	SCREWS/ANCHORS	8

### STEP 1

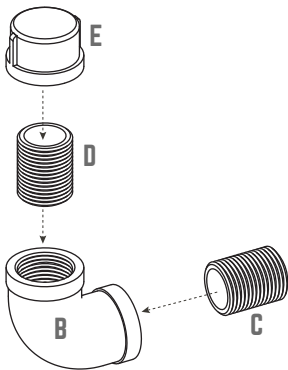

### STEP 2

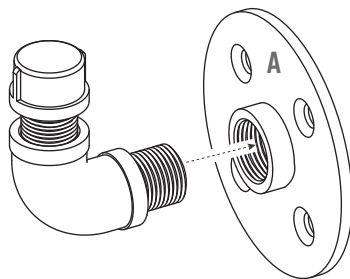

### STEP 3

- Place flange against wall in desired location and mark holes with pencil
- Using stud finder, locate and mark wall stud if found
- If a wall stud is present**, attach flange to wall with included screws
- If no wall stud is present:**
  - A) Drill pilot holes in wall using 1/4" drill bit
  - B) Insert anchor fully into pilot hole using hammer and Phillips screwdriver as needed
- Attach flange to wall using included screws

Anchors will be installed  
**IF NO WALL STUD IS PRESENT.**

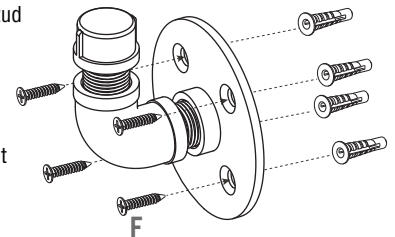

## HOW TO PREVENT PIPE CORROSION

PIPE DECOR industrial-grade black pipes and fittings are coated with a rust-preventive oil during manufacturing. For best results, **SEAL THE PIPES TO AVOID ANY RUSTING** after cleaning the kit.

### CLEAN AND SEAL INSTRUCTIONS:

- CLEAN:** Recommended supplies: regular degreasing dish soap, washcloths, gloves (optional)
1. Wash your pipes and fittings with warm water and dish soap until the oil is completely removed.
  2. Wipe the pipes with a dry washcloth and wait until the pipes are completely dry.

**IMPORTANT: THE PIPES MUST BE COMPLETELY DRY BEFORE YOU START THE SEALING PROCESS.**

### **SEAL:**

**IF USING POLYURETHANE SPRAY:** Spray each dry pipe and fitting with a polyurethane matte or satin finishing spray and let it dry before assembling the kit.

**IF USING FINISHING WAX:** Coat each dry pipe with a finishing wax. Wait for 20 minutes, then polish the pipe with a dry washcloth by wiping them down. Faster wiping will result in a shinier finish.