

UHF Single Bay Dipole

Electrical Specifications

Frequency (Continuous)	360-520 MHz
Gain	2.5 dBd
Power Rating (Max.)	500 W
Polarization	Vertical
VSWR (Max.)	1.5:1
E Plane	80°
H Plane	See pattern
Impedance (Nom.)	50 Ω
Lightning Protection	DC Grounded
RF Connector Type	N Male

Mechanical Specifications

Cable Type	RG 214
Antenna Dimensions (HxWxD)	11.5" x 32.3" x 1.5"
Tower Weight (Antenna+Mounts)	5 lbs.
Mounting	Each dipole element includes a heavy duty stainless steel bracket for mounting to a 1.5-2.5" diameter mast. Antenna may be mounted at 1/4, 1/2 or full wave spacing. Mast is customer supplied.
Material	Electropolished Stainless Steel

Environmental Specifications

Wind Rating	175 MPH
Wind Rating 1/2" Ice	150 MPH
Exposed Area (Max.)	0.27 ft. ²
Lateral Thrust	11 lbs @ 100MPH

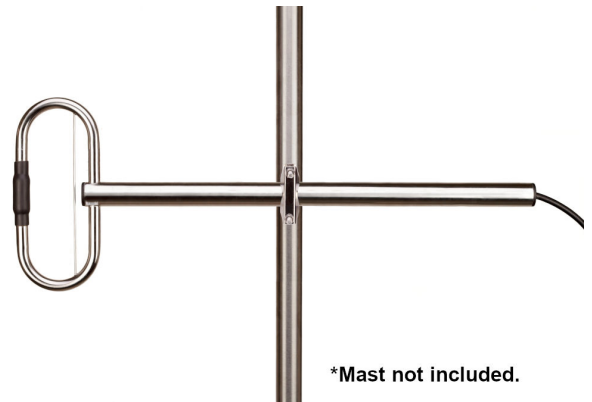

The EMR450DP single bay dipole is a rugged, all electropolished stainless steel, folded broadband dipole for use in the 360-520 MHz band. It is all stainless steel construction, suited to harsh environments. This antenna can be mounted in three configurations to allow for different shaped radiation patterns in the H plane, including 1/4, 1/2 and Full Wave length spacing from the vertical mounting pole.

Product Features

- Broad VSWR bandwidth
- Stainless steel construction
- Weather and corrosion resistance
- No tuning required, plug & play
- Ideal for Public Safety, Government, LMR, and Railroad Applications
- 3 Year Warranty

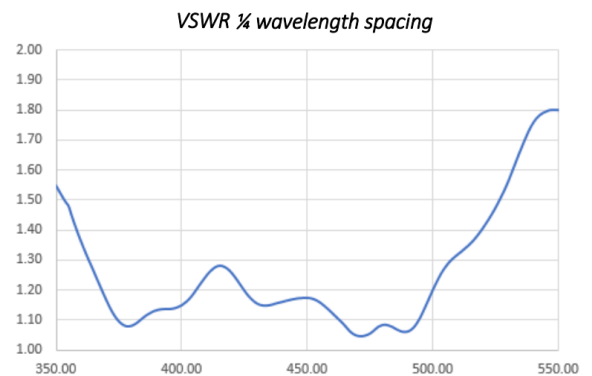
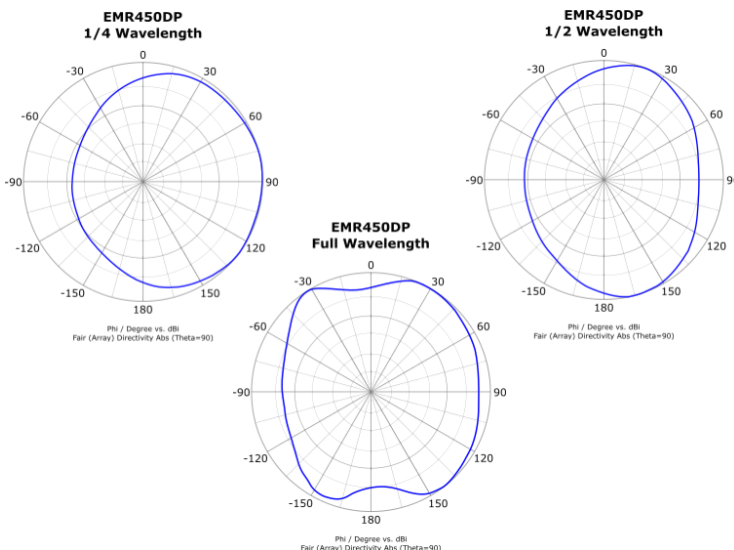

All product specifications subject to change without notice.

Copyright © 2020 EMR Corporation. All rights reserved.

UHF Dipole Antenna Installation Instructions

EMR450DP Supplied Components:

- (x1) - UHF folded dipole w/ boom
- (x1) - Angled mounting bracket
- (x4) - Screws w/ captive washers
- (x1) - Anti seize compound
- (x1) - Installation instructions



Angled Mounting Bracket

Assembling the Antenna:

The dipole antenna element must be securely attached to the boom. Feed the antenna tail through the boom, then insert and tighten included screws with captive washers to secure the boom to the antenna.

Mounting the Antenna to the Mast:

1. **Drain hole must be facing down on the dipole element.**
2. Secure the antenna to the mast with mounting bracket.
3. Apply anti-seize compound to bracket threads.
4. Ensure antenna is set to optimal H pattern before tightening brackets (see Radiation Pattern Options).
5. All connectors must be correctly waterproofed (See Waterproofing RF Connections).

Antenna Mounting Dimensions:

Dimensions for mounting the antenna to the support structure are specified in the illustrations to the right. Adjust distance between dipole element and support structure to achieve the desired radiation pattern.

Radiation Pattern Options:

Mounting spacings to achieve desired H plane radiation patterns are indicated with stickers on the antenna boom. See specification sheet for radiation patterns. Mount the antenna to the support structure at the corresponding distance (Dimension A) to achieve desired spacing:

Wave Length	Frequency	Dimension A
1/4 Wave	360-520 MHz	6.4"
1/2 Wave	360-520 MHz	12.8"
1 Wave	360-520 MHz	25.7"

Side Mount Configuration

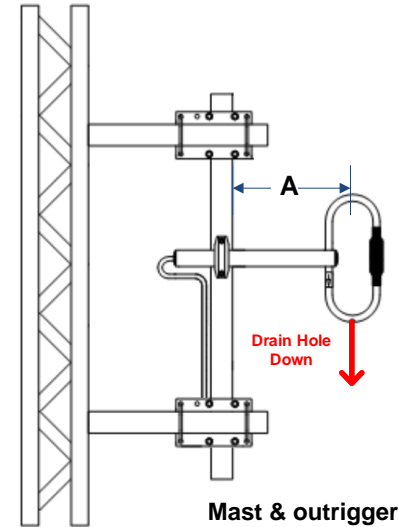

Top Mount Configuration

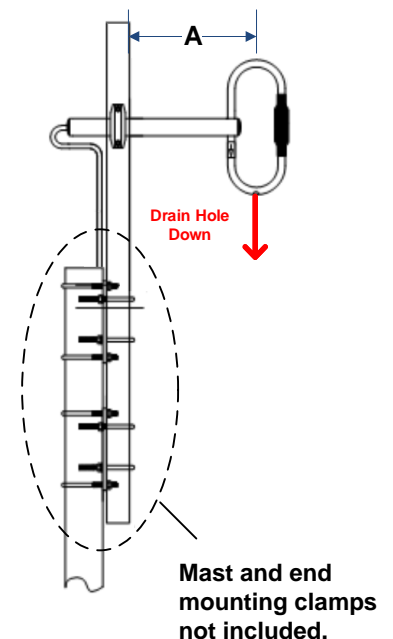

UHF Dipole Antenna Installation Instructions

Waterproofing RF Connections

The RF connections between the antenna tail and the RF feeder cable must be water protected. Water incursions can short-out the inner and outer conductors of the coaxial cable, producing heavy attenuation of RF signals. If water gets into the connectors, it can degrade the antenna performance to the point that the antenna will need to be re-installed and the cables may need to be repaired or replaced. The method consists of using multiple layers of three different types of electrical tape over the RF connectors and first 4-8" of RF cable. Critically the taping must extend beyond the end of any heat-shrink that is part of the N-type connector assembly on the RF cable.

Recommended tape to use

1. 3M Scotch No 23 Self Bonding Electrical Tape
2. 3M Scotch 2228 Rubber Mastic
3. 3M Scotch Super 33+ Vinyl Electrical Tape

1) Temporarily secure the RF cable such that it extends vertically directly from the connector for 30cm or so before bending. This will ease application of the as it maximizes the clearance from the antenna vane.

2) Apply two layers of No. 23 tape over the lock washer, nut, N-thread and N-type connector. The tape must be stretched to 75% of its original width for all layers to ensure good bonding. Each successive turn of the tape should overlap the previous turn by half the width of the tape. Apply a single layer of No. 2228 rubber mastic tape over the No. 23 tape. This layer must extend a minimum of 0.79" beyond the existing No. 23 tape. For the inverted element, start at the tongue and wrap up to the cable. For the non-inverted element start on the cable and wrap up to the tongue. Each successive turn is overlapped by half the width of the tape. Minimum tension should be put on the No. 2228 tape as it is being applied

3) Apply a single layer of No. 2228 rubber mastic tape over the No. 23 tape. This layer must extend a minimum of 0.79" beyond the existing No. 23 tape. For the inverted element, start at the tongue and wrap up to the cable. For the non-inverted element start on the cable and wrap up to the tongue. Each successive turn is overlapped by half the width of the tape. Minimum tension should be put on the No. 2228 tape as it is being applied. Additional tape may be used to build up uneven parts of the connector interface to create a smoother surface for subsequent layers of tape. Gently knead the No. 2228 tape to ensure it seals to itself and removes any air voids.

4) Apply two layers of No. 23 tape over the No. 2228 tape, extending a minimum of 0.97" beyond the end of the existing tape. Stretch the tape to 75% of its original width for all layers to ensure good bonding. Each successive turn of the tape should overlap the previous turn by half the width of the tape. For the inverted element, start on the cable and wrap down to the tongue before wrapping back up the cable extending beyond the start of the tape for water shedding. For the non-inverted element start at the tongue and wrap down the cable before wrapping back up to the tongue.

5) Apply two layers of No. 33+ tape over the No. 23 tape, extending a minimum of .79" beyond the existing tape. Stretch the tape to 65% of its original width for the first layer. Apply the second layer without any tension. Each successive turn of the tape should overlap the previous turn by half the width of the tape.

For the inverted element, start at on the cable and wrap down to the tongue before wrapping back up the cable extending beyond the start of the tape for water shedding. For the non-inverted start at the tongue and wrap down the cable before wrapping back up to the tongue. The finished seal should be smooth without any No. 23 or No. 2228 tape exposed.

Alternative Method – Tape + Cold Shrink

This approach is initially similar to the recommended approach, although replacing the outer two layers of tape with the application of a cold shrink sleeve such as a SL-TN-90 from Gamma Electronics or an equivalent product. Cold shrink with an IP68 rating provides a waterproof layer in addition to UV protection. It is faster install than the multiple layers of tape required in step 4 and 5.

Thread required quantity of cold shrink tubes onto the RF cable prior to attaching the cable to the element. If a single tube is too short to cover required area, use multiple cold shrink tubes. Orientation is important, tubes should be threaded onto the RF cables contacting from the tongue end first. Meaning the "pull tab" will be furthest from the tongue and N-connector. Attach the antenna RF tail to the feeder cable. Temporarily secure RF cable so it extends vertically from connector for 1.54" or so before bending.

This will ease the application of the tape as it maximizes the clearance from the antenna vane. Apply 2 layers of No. 23 tape over nut, N-thread and N-type plug connector. Tape must be stretched to 75% of original width to ensure all layers overlap previous turn by half width of tape. This should completely cover exposed metals as well as any heat shrink on cable. Layers should be continuous, starting from top and proceeding in successive half lapped layers downwards before reversing direction and finishing back at the top.

Apply single layer of No. 2228 rubber mastic tape over No. 23 tape. Layer must extend 0.79" beyond existing No. 23 tape. Each successive turn is overlapped by half width of the tape. Minimal tension should be applied to No. 2228 tape as it is being applied. Additional tape can be used for uneven areas to create smoother areas. Gently knead No. 2228 tape to ensure its sealed.

Slide cold shrink tube along cable until it completely covers connector and presses up against the tongue. Pull the plastic thread to start contracting the cold shrink from the tongue end. Continue to apply pressure to the cold shrink as it contracts to ensure that it closes flush against the tongue. Cold shrink needs to extend .79" beyond the end of No. 2228 tape.

Bird Protection

It is important to note that birds such as cockatoos can cause damage to RF cabling, in particular waterproof taping. To remedy this issue a stainless-steel spiral conduit can be used to cover the RF cabling including the element connectors.