

## VHF Dual Bay Dipole Antenna

### Electrical Specifications

Frequency (Continuous)	136-174 MHz
Gain	4 - 5.5 dBd (depending on spacing)
Power Rating (Max.)	500 W
Bandwidth	38 MHz
VSWR (Max.)	1.5:1
E Plane	35° @ 1/4 Wavelength
H Plane	See pattern
Impedance (Nom.)	50 Ω
Lightning Protection	DC Grounded
RF Connector Type	N Male

### Mechanical Specifications

Cable Type	RG 214
Antenna Dimensions (HxWxD)	32.3" x 51.2" x 2" (each element)
Tower Weight (Antenna+Mounts)	24 lbs.
Mounting	Each dipole element includes a heavy duty stainless steel bracket for mounting to a 1.5-2.5" diameter mast. Antennas may be mounted at 1/4 or 1/2 spacing. Mast is customer supplied.
Material	Electropolished Stainless Steel

### Environmental Specifications

Wind Rating	175 MPH
Wind Rating 1/2" Ice	150 MPH
Exposed Area (Max.)	1.6 ft. <sup>2</sup>
Lateral Thrust	64 lbs @ 100MPH

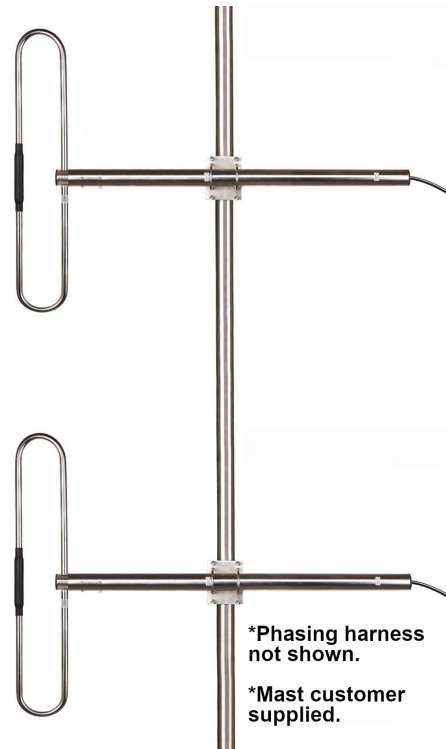

The EMR150DP2 antenna is an all electropolished stainless steel, folded dipole antenna for use in the High Band VHF commercial radio band. Its wide bandwidth is ideal in duplexing and multicoupling applications where numerous operators are required to be connected to one antenna system. This dual antenna configuration includes all necessary bracketry and phasing harness to stack the antennas for increased gain. Its robust construction ensures excellent longevity and performance.

### Product Features

- Wide band
- Stainless steel construction
- Weather and corrosion resistance
- No tuning required, plug & play
- Ideal for Public Safety, Government, LMR, and Railroad Applications
- 3 Year Warranty

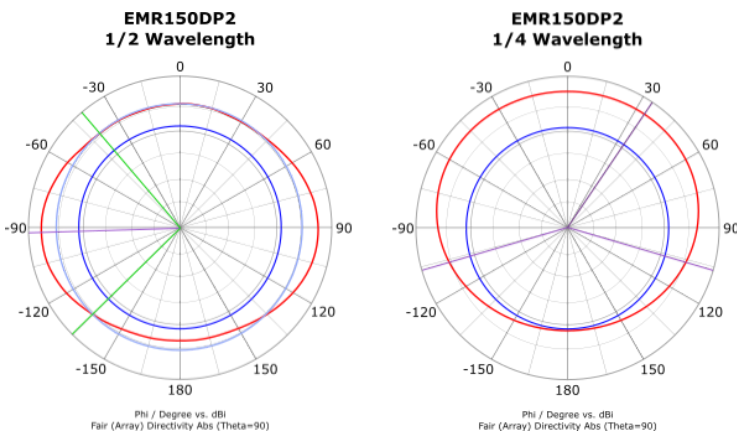

## VHF Dipole Antenna Installation Instructions

### EMR150DP2 Supplied Components:

- (x2) - VHF folded dipole w/ boom
- (x2) - Angled mounting bracket
- (x8) - Screws w/ captive washers
- (x2) - Anti seize compound
- (x1) - 2-way phasing harness
- (x1) - Installation instructions

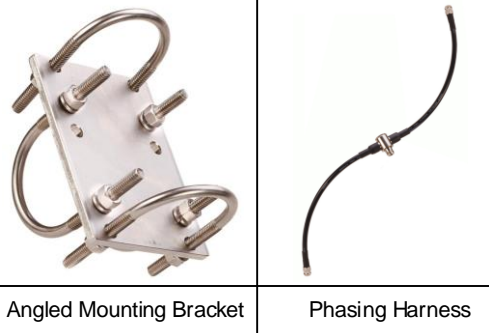

### Assembling the Antennas:

Each dipole antenna element must be securely attached to the boom. Feed the antenna tail through the boom, then insert and tighten included screws w/ captive washers to secure the boom to the antenna.

### Mounting Antennas to the Mast:

1. **Drain holes must be facing down on each dipole element.**
2. Secure the antennas to the mast with mounting bracket.
3. Apply anti-seize compound to bracket threads.
4. Ensure antennas are set to optimal H pattern before tightening brackets (see Radiation Pattern Options) .
5. Attach the phasing harness between multiple antennas.
6. Phasing harness, junction box and all connectors must be correctly waterproofed (See Waterproofing RF Connections).

### Antenna Mounting Dimensions:

Dimensions for mounting the antenna to the support structure are specified in the illustrations to the right:

- A. Distance between dipole element and support structure  
(See Radiation Pattern Options).
- B. Distance between dipole and ends of mast or outrigger clamps.
- C. Distance between dipole centers.
- D. Minimal mast length (Top or Side Mount Configurations vary).

### Radiation Pattern Options:

Mounting spacings to achieve desired H plane radiation patterns are indicated with stickers on the antenna boom. See antenna specification sheet for radiation patterns. Mount the antenna to the support structure at the corresponding distance (Dimension A) to achieve desired spacing:

Wave Length	Frequency	Dimension A	Phasing Harness
1/4 Wave	136-174 MHz	18.3"	PH150DP
1/2 Wave	136-174 MHz	36.7"	PH150DP
1 Wave	136-174 MHz	73.4"	PH150DP

### Side Mount Configuration

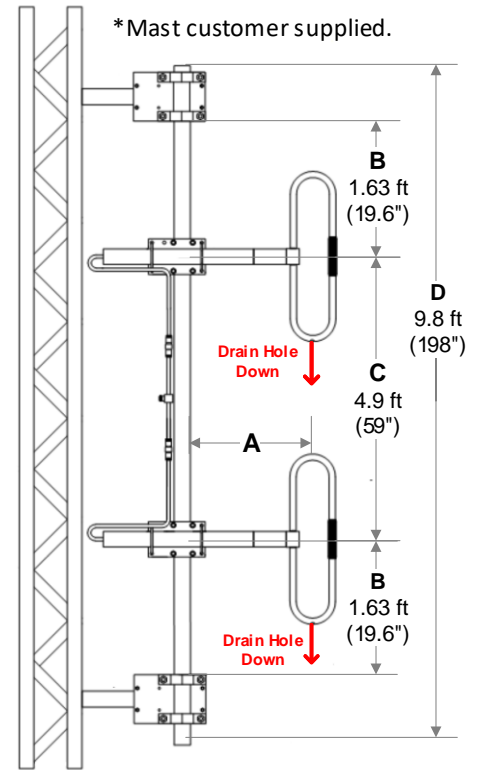

### Top Mount Configuration

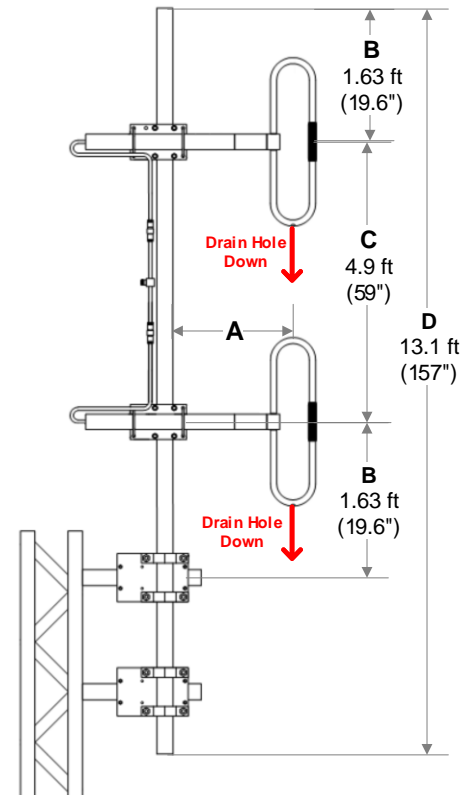

# VHF Dipole Antenna Installation Instructions

## **Waterproofing RF Connections**

The RF connections between the antenna tail and the RF feeder cable must be water protected. Water incursions can short-out the inner and outer conductors of the coaxial cable, producing heavy attenuation of RF signals. If water gets into the connectors, it can degrade the antenna performance to the point that the antenna is unusable. If this occurs the antenna will need to be re-installed and the cables may need to be repaired or replaced. The method consists of using multiple layers of three different types of electrical tape over the RF connectors and first 4-8" of RF cable. Critically the taping must extend beyond the end of any heat-shrink that is part of the N-type connector assembly on the RF cable.

## **Recommended tape to use**

1. 3M Scotch No 23 Self Bonding Electrical Tape
2. 3M Scotch 2228 Rubber Mastic
3. 3M Scotch Super 33+ Vinyl Electrical Tape

- 1) Temporarily secure the RF cable such that it extends vertically directly from the connector for 30cm or so before bending. This will ease application of the as it maximizes the clearance from the antenna vane.
- 2) Apply two layers of No. 23 tape over the lock washer, nut, N-thread and N-type connector. The tape must be stretched to 75% of its original width for all layers to ensure good bonding. Each successive turn of the tape should overlap the previous turn by half the width of the tape. Apply a single layer of No. 2228 rubber mastic tape over the No. 23 tape. This layer must extend a minimum of 0.79" beyond the existing No. 23 tape. For the inverted element, start at the tongue and wrap up to the cable. For the non-inverted element start on the cable and wrap up to the tongue. Each successive turn is overlapped by half the width of the tape. Minimum tension should be put on the No. 2228 tape as it is being applied
- 3) Apply a single layer of No. 2228 rubber mastic tape over the No. 23 tape. This layer must extend a minimum of 0.79" beyond the existing No. 23 tape. For the inverted element, start at the tongue and wrap up to the cable. For the non-inverted element start on the cable and wrap up to the tongue. Each successive turn is overlapped by half the width of the tape. Minimum tension should be put on the No. 2228 tape as it is being applied. Additional tape may be used to build up uneven parts of the connector interface to create a smoother surface for subsequent layers of tape. Gently knead the No. 2228 tape to ensure it seals to itself and removes any air voids.
- 4) Apply two layers of No. 23 tape over the No. 2228 tape, extending a minimum of 0.97" beyond the end of the existing tape. Stretch the tape to 75% of its original width for all layers to ensure good bonding. Each successive turn of the tape should overlap the previous turn by half the width of the tape. For the inverted element, start on the cable and wrap down to the tongue before wrapping back up the cable extending beyond the start of the tape for water shedding. For the non-inverted element start at the tongue and wrap down the cable before wrapping back up to the tongue.
- 5) Apply two layers of No. 33+ tape over the No. 23 tape, extending a minimum of .79" beyond the existing tape. Stretch the tape to 65% of its original width for the first layer. Apply the second layer without any tension. Each successive turn of the tape should overlap the previous turn by half the width of the tape.

For the inverted element, start at on the cable and wrap down to the tongue before wrapping back up the cable extending beyond the start of the tape for water shedding. For the non-inverted start at the tongue and wrap down the cable before wrapping back up to the tongue. The finished seal should be smooth without any No. 23 or No. 2228 tape exposed.

## **Alternative Method – Tape + Cold Shrink**

This approach is initially similar to the recommended approach, although replacing the outer two layers of tape with the application of a cold shrink sleeve such as a SL-TN-90 from Gamma Electronics or an equivalent product. Cold shrink with an IP68 rating provides a waterproof layer in addition to UV protection. It is faster install than the multiple layers of tape required in step 4 and 5.

Thread required quantity of cold shrink tubes onto the RF cable prior to attaching the cable to the element. If a single tube is too short to cover required area, use multiple cold shrink tubes. Orientation is important, tubes should be threaded onto the RF cables contacting from the tongue end first. Meaning the "pull tab" will be furthest from the tongue and N-connector. Attach the antenna RF tail to the feeder cable. Temporarily secure RF cable so it extends vertically from connector for 1.54" or so before bending.

This will ease the application of the tape as it maximizes the clearance from the antenna vane. Apply 2 layers of No. 23 tape over nut, N-thread and N-type plug connector. Tape must be stretched to 75% of original width to ensure all layers overlap previous turn by half width of tape. This should completely cover exposed metals as well as any heat shrink on cable. Layers should be continuous, starting from top and proceeding in successive half lapped layers downwards before reversing direction and finishing back at the top.

Apply single layer of No. 2228 rubber mastic tape over No. 23 tape. Layer must extend 0.79" beyond existing No. 23 tape. Each successive turn is overlapped by half width of the tape. Minimal tension should be applied to No. 2228 tape as it is being applied. Additional tape can be used for uneven areas to create smoother areas. Gently knead No. 2228 tape to ensure its sealed.

Slide cold shrink tube along cable until it completely covers connector and presses up against the tongue. Pull the plastic thread to start contracting the cold shrink from the tongue end. Continue to apply pressure to the cold shrink as it contracts to ensure that it closes flush against the tongue. Cold shrink needs to extend .79" beyond the end of No. 2228 tape.

## **Bird Protection**

It is important to note that birds such as cockatoos can cause damage to RF cabling, in particular waterproof taping. To remedy this issue a stainless-steel spiral conduit can be used to cover the RF cabling including the element connectors.