

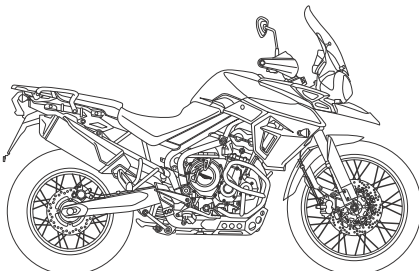

Owner's Handbook

Tiger XCA, Tiger XCx, Tiger XR, Tiger XRt, Tiger XRx and Tiger XRx-LRH

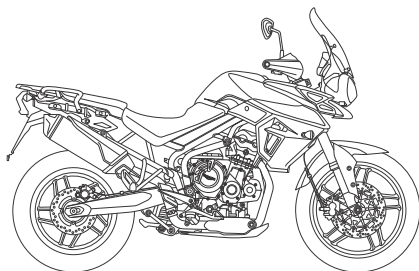

This handbook contains information on the Triumph Tiger XCA, Tiger XCx, Tiger XR, Tiger XRt, Tiger XRx and Tiger XRx-LRH motorcycles. Always store this Owner's Handbook with the motorcycle and refer to it for information whenever necessary.

The information contained in this publication is based on the latest information available at the time of printing. Triumph reserves the right to make changes at any time without prior notice, or obligation.

Not to be reproduced wholly or in part without the written permission of Triumph Motorcycles Limited.

© Copyright 08.2017 Triumph Motorcycles Limited, Hinckley, Leicestershire, England.

Publication part number 3855528-EN issue 1

TABLE OF CONTENTS

This handbook contains a number of different sections. The table of contents below will help you find the beginning of each section where, in the case of the major sections, a further table of contents will help you find the specific subject required.

Foreword.....	3
Safety First.....	7
Warning Labels.....	14
Parts Identification.....	16
Serial Numbers.....	22
Instruments.....	23
General Information.....	76
How to Ride the Motorcycle.....	118
Accessories, Loading and Passengers.....	130
Maintenance.....	134
Cleaning and Storage.....	186
Specifications.....	196
Index.....	201

FOREWORD

Owner's Handbook

 **Warning**

This Owner's Handbook, and all other instructions that are supplied with your motorcycle, should be considered a permanent part of your motorcycle and should remain with it even if your motorcycle is subsequently sold.

All riders must read this Owner's Handbook and all other instructions which are supplied with your motorcycle, before riding, in order to become thoroughly familiar with the correct operation of your motorcycle's controls, its features, capabilities and limitations. Do not lend your motorcycle to others as riding when not familiar with your motorcycle's controls, features, capabilities and limitations can lead to an accident.

Thank you for choosing a Triumph motorcycle. This motorcycle is the product of Triumph's use of proven engineering, exhaustive testing, and continuous striving for superior reliability, safety and performance.

Please read this Owner's Handbook before riding in order to become thoroughly familiar with the correct operation of your motorcycle's controls, its features, capabilities and limitations.

This handbook includes safe riding tips, but does not contain all the techniques and skills necessary to ride a motorcycle safely.

Triumph strongly recommends that all riders undertake the necessary training to ensure safe operation of this motorcycle.

This handbook is available from your local dealer in:

- English
- US English
- French
- German
- Italian
- Dutch
- Spanish
- Portuguese
- Swedish
- Japanese
- Thai.

Talk to Triumph

Our relationship with you does not end with the purchase of your Triumph. Your feedback on the buying and ownership experience is very important in helping us develop our products and services for you.

Please help us by ensuring your authorised Triumph dealership has your email address and registers this with us. You will then receive an online customer satisfaction survey invitation to your email address where you can give us this feedback.

Your Triumph Team.

Foreword

Warnings, Cautions and Notes

Throughout this Owner's Handbook particularly important information is presented in the following form:

 **Warning**

This warning symbol identifies special instructions or procedures, which if not correctly followed could result in personal injury, or loss of life.

 **Caution**

This caution symbol identifies special instructions or procedures, which, if not strictly observed, could result in damage to, or destruction of, equipment.

Note:

- This note symbol indicates points of particular interest for more efficient and convenient operation.

Warning Labels



At certain areas of the motorcycle, the symbol (above) can be seen. The symbol means 'CAUTION: REFER TO THE HANDBOOK' and will be followed by a pictorial representation of the subject concerned.

Never attempt to ride the motorcycle or make any adjustments without reference to the relevant instructions contained in this handbook.

See page **14** for the location of all labels bearing this symbol. Where necessary, this symbol will also appear on the pages containing the relevant information.

Maintenance

To ensure a long, safe and trouble free life for your motorcycle, maintenance should only be carried out by an authorised Triumph dealer.

Only an authorised Triumph dealer will have the necessary knowledge, equipment and skills to maintain your Triumph motorcycle correctly.

To locate your nearest authorised Triumph dealer, visit the Triumph web site at www.triumph.co.uk or telephone the authorised distributor in your country. Their address is given in the service record book that accompanies this handbook.

Off-road Use

The motorcycles are designed for on-road and light off-road use. Light off-road use includes use on unpaved, dirt or gravel roads, but does not include riding on any motocross course, any off-road competition (such as motocross or enduro riding), or riding off-road with a passenger.

Light off-road use does not include jumping the motorcycle or riding over obstacles. Do not attempt to jump over any bumps or obstacles. Do not attempt to ride over any obstacles.

Noise Control System

Tampering with the noise control system is prohibited.

Owners are warned that the law may prohibit:

1. The removal or rendering inoperative by any person other than for purposes of maintenance, repair or replacement, of any device or element of design incorporated into any new vehicle for the purpose of noise control prior to its sale or delivery to the ultimate purchaser or while it is in use and,
2. the use of the vehicle after such device or element of design has been removed or rendered inoperative by any person.

Foreword

Immobiliser and Tyre Pressure Monitoring System

This device complies with part 15 of the Federal Communications Commission (FCC) Rules.

Operation is subject to the following two conditions:

1. This device may not cause harmful interference.
2. This device must accept any interference received, including interference that may cause undesired operation.

Changes or modifications to the device could void the user's authority to operate the equipment.

Tyres

With reference to the Pneumatic Tyres and Tubes for Automotive Vehicles (Quality Control) Order, 2009, Cl. No. 3 (c), it is declared by M/s. Triumph Motorcycles Ltd. that the tyres fitted on this motorcycle meet the requirements of IS 15627: 2005 and comply with the requirements under Central Motor Vehicle Rules (CMVR), 1989.

Tiger 800 XRX - LRH Model

Unless stated otherwise, the information, instructions, and specifications for Tiger 800 XRX - LRH (low ride height) models are identical to those detailed in this Owner's Handbook for the Tiger 800 XRX standard ride height models.

SAFETY FIRST

The Motorcycle

Warning

The motorcycles are designed for on-road and light off-road use. Light off-road use includes use on unpaved, dirt or gravel roads, but does not include riding on any motocross course, any off-road competition (such as motocross or enduro riding), or riding off-road with a passenger.

Light off-road use does not include jumping the motorcycle or riding over obstacles. Do not attempt to jump over any bumps or obstacles. Do not attempt to ride over any obstacles.

Extreme off-road use could lead to loss of motorcycle control and an accident.

Warning

Tiger XRX - LRH (Low Ride Height) Models

The Tiger 800 XRX - LRH motorcycles are equipped with lowered suspension and have reduced ground clearance.

As a result, the cornering banking angles that can be achieved by the Tiger 800 XRX - LRH are reduced, when compared with the standard ride height Tiger 800 XRX models.

When riding, bear in mind that your motorcycle's ground clearance is limited. Operate your motorcycle in an area free from traffic to gain familiarity with the motorcycle's ground clearance and bank angle limitations.

Banking to an unsafe angle or unexpected contact with the ground may cause instability, loss of motorcycle control and an accident.

Warning

This motorcycle is not designed to tow a trailer or be fitted with a sidecar.

Fitting a sidecar and/or a trailer may result in loss of control and an accident.

Safety First

Warning

This motorcycle is designed for use as a two-wheeled vehicle capable of carrying a rider on his/her own, or a rider and one passenger.

The total weight of the rider, and any passenger, accessories and luggage must not exceed the maximum load limit of 222 kg (489 lbs).

Warning

This motorcycle is fitted with a catalytic converter below the engine, which along with the exhaust system reaches a very high temperature during engine operation.

Flammable materials such as grass, hay/straw, leaves, clothing and luggage etc. could ignite if allowed to come into contact with any part of the exhaust system and catalytic converter; always ensure flammable materials are not allowed to contact the exhaust system or catalytic converter.

Fuel and Exhaust Fumes

Warning

PETROL IS HIGHLY FLAMMABLE:

Always turn off the engine when refuelling.

Do not refuel or open the fuel filler cap while smoking or in the vicinity of any open (naked) flame.

Take care not to spill any petrol on the engine, exhaust pipes or silencers when refuelling.

If petrol is swallowed, inhaled or allowed to get into the eyes, seek immediate medical attention.

Spillage on the skin should be immediately washed off with soap and water and clothing contaminated with petrol should immediately be removed.

Burns and other serious skin conditions may result from contact with petrol.

Warning

Never start your engine or let it run for any length of time in a closed area.

The exhaust fumes are poisonous and may cause loss of consciousness and death within a short time.

Always operate your motorcycle in the open-air or in an area with adequate ventilation.

Helmet and Clothing

! Warning



When riding the motorcycle, both rider and passenger (on models where carrying a passenger is permitted) must always wear a motorcycle helmet, eye protection, gloves, boots, trousers (close fitting around the knee and ankle) and a brightly coloured jacket.

Brightly coloured clothing will considerably increase a rider's (or passenger's) visibility to other operators of road vehicles.

Although full protection is not possible, wearing correct protective clothing can reduce the risk of injury when riding.

! Warning

A helmet is one of the most important pieces of riding gear as it offers protection against head injuries. You and your passenger's helmet should be carefully chosen and should fit you or your passenger's head comfortably and securely. A brightly coloured helmet will increase a rider's (or passenger's) visibility to other operators of road vehicles.

An open face helmet offers some protection in an accident though a full face helmet will offer more.

Always wear a visor or approved goggles to help vision and to protect your eyes.

Safety First

Riding

Warning

Never ride the motorcycle when fatigued or under the influence of alcohol or other drugs.

Riding when under the influence of alcohol or other drugs is illegal.

Riding when fatigued or under the influence of alcohol or other drugs reduces the rider's ability to maintain control of the motorcycle and may lead to loss of control and an accident.

Warning

All riders must be licenced to operate the motorcycle. Operation of the motorcycle without a licence is illegal and could lead to prosecution.

Operation of the motorcycle without formal training in the correct riding techniques that are necessary to become licenced is dangerous and may lead to loss of motorcycle control and an accident.

Warning

Always ride defensively and wear the protective equipment mentioned elsewhere in this foreword. Remember, in an accident, a motorcycle does not give the same impact protection as a car.

Warning

This Triumph motorcycle should be operated within the legal speed limits for the particular road travelled. Operating a motorcycle at high speeds can be potentially dangerous since the time available to react to given traffic situations is greatly reduced as road speed increases. Always reduce speed in potentially hazardous driving conditions such as bad weather or heavy traffic.

Warning

Continually observe and react to changes in road surface, traffic and wind conditions. All two-wheeled vehicles are subject to external forces which may cause an accident. These forces include but are not limited to:

- Wind draft from passing vehicles
- Potholes, uneven or damaged road surfaces
- Bad weather
- Rider error.

Always operate the motorcycle at moderate speed and away from heavy traffic until you have become thoroughly familiar with its handling and operating characteristics. Never exceed the legal speed limit.

Handlebars and Footrests

Warning

The rider must maintain control of the vehicle by keeping hands on the handlebars at all times.

The handling and stability of a motorcycle will be adversely affected if the rider removes his hands from the handlebars, resulting in loss of motorcycle control and an accident.

Warning

The rider and passenger must always use the footrests provided, during operation of the vehicle.

By using the footrests, both rider and passenger will reduce the risk of inadvertent contact with any motorcycle components and will also reduce the risk of injury from entrapment of clothing.

Warning

The bank angle indicators must not be used as a guide to how far the motorcycle may be safely banked. This depends on many various conditions including, but not limited to, road surface, tyre condition and weather.

Banking to an unsafe angle may cause instability, loss of motorcycle control and an accident.

Warning

Use of a motorcycle with the bank angle indicators worn beyond the maximum limit will allow the motorcycle to be banked to an unsafe angle.

The bank angle indicators have reached the maximum wear limit and should be replaced when they have worn down to a length of:

20 mm - All models except Tiger 800 XCA

25 mm - Tiger 800 XCA only.

Banking to an unsafe angle may cause instability, loss of motorcycle control and an accident.

Safety First

! Warning

When banking and the bank angle indicator, attached to the rider's footrest, makes contact with the ground, the motorcycle is nearing its bank angle limit. A further increase of the banking angle is unsafe.

Banking to an unsafe angle may cause instability, loss of motorcycle control and an accident.

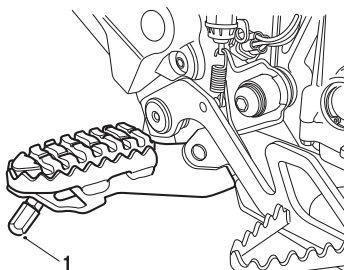

1. Bank angle indicator

Parking

! Warning

Always switch off the engine and remove the ignition key before leaving the motorcycle unattended. By removing the key, the risk of use of the motorcycle by unauthorised or untrained persons is reduced.

When parking the motorcycle, always remember the following:

- Engage first gear to help prevent the motorcycle from rolling off the stand.
- The engine and exhaust system will be hot after riding. DO NOT park where pedestrians, animals and/or children are likely to touch the motorcycle.
- Do not park on soft ground or on a steeply inclined surface. Parking under these conditions may cause the motorcycle to fall over.

For further details, please refer to the 'How to Ride the Motorcycle' section of this Owner's Handbook.

Parts and Accessories

Warning

Owners should be aware that the only approved parts, accessories and conversions for any Triumph motorcycle are those which carry official Triumph approval and are fitted to the motorcycle by an authorised dealer.

In particular, it is extremely hazardous to fit or replace parts or accessories whose fitting requires the dismantling of, or addition to, either the electrical or fuel systems and any such modification could cause a safety hazard.

The fitting of any non-approved parts, accessories or conversions may adversely affect the handling, stability or other aspect of the motorcycle operation that may result in an accident causing injury or death.

Triumph does not accept any liability whatsoever for defects caused by the fitting of non-approved parts, accessories or conversions or the fitting of any approved parts, accessories or conversions by non-approved personnel.

Maintenance/Equipment

Warning

Consult your authorised Triumph dealer whenever there is doubt as to the correct or safe operation of this Triumph motorcycle.

Remember that continued operation of an incorrectly performing motorcycle may aggravate a fault and may also compromise safety.

Warning

Ensure all equipment that is required by law is installed and functioning correctly. The removal or alteration of the motorcycle's lights, silencers, emission or noise control systems can violate the law. Incorrect or improper modification may adversely affect the handling, stability or other aspect of the motorcycle operation, which may result in an accident causing injury or death.

Warning

If the motorcycle is involved in an accident, collision or fall, it must be taken to an authorised Triumph dealer for inspection and repair. Any accident can cause damage to the motorcycle that, if not correctly repaired, may cause a second accident that may result in injury or death.

Warning Labels

WARNING LABELS

Warning Label Locations

The labels detailed on this and the following pages draw your attention to important safety information in this handbook. Before riding, make sure that all riders have understood and complied with all the information to which these labels relate.

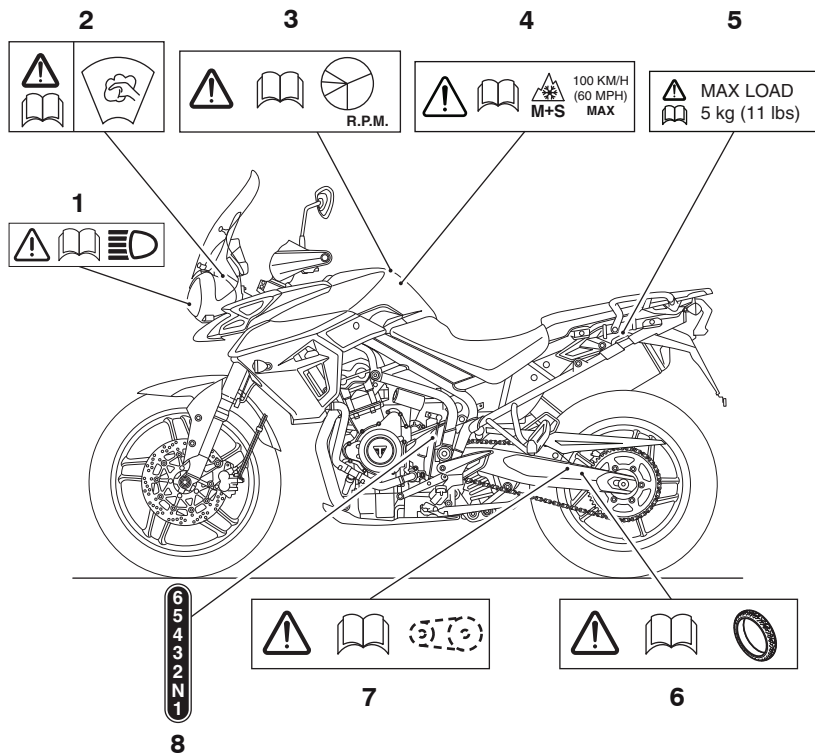

1. Headlight (page 180)
2. Windscreen (if fitted) (page 192)
3. Running-In (page 116)
4. Mud and Snow Tyres (page 196)

5. Panniers (if fitted) (page 130)
6. Tyres (page 167)
7. Drive Chain (page 148)
8. Gear Position (page 122)

Warning Label Locations (continued)

! Caution

All warning labels and decals, with the exception of the Running-in label, are fitted to the motorcycle using a strong adhesive. In some cases, labels are installed prior to an application of paint lacquer. Therefore, any attempt to remove the warning labels will cause damage to the paintwork or bodywork.

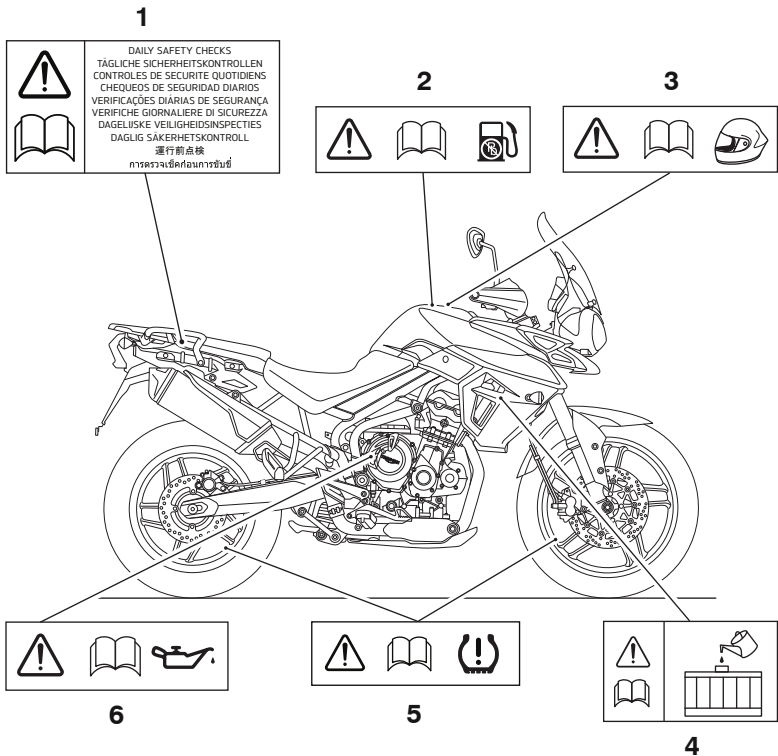

1. Daily Safety Checks (page 117)
2. Unleaded Fuel (page 97)
3. Helmet (page 9)
4. Coolant (page 143)

5. Tyre Pressure Monitoring System (if fitted) (page 169)
6. Engine Oil (page 140)

Parts Identification

PARTS IDENTIFICATION

Tiger 800 XR Models

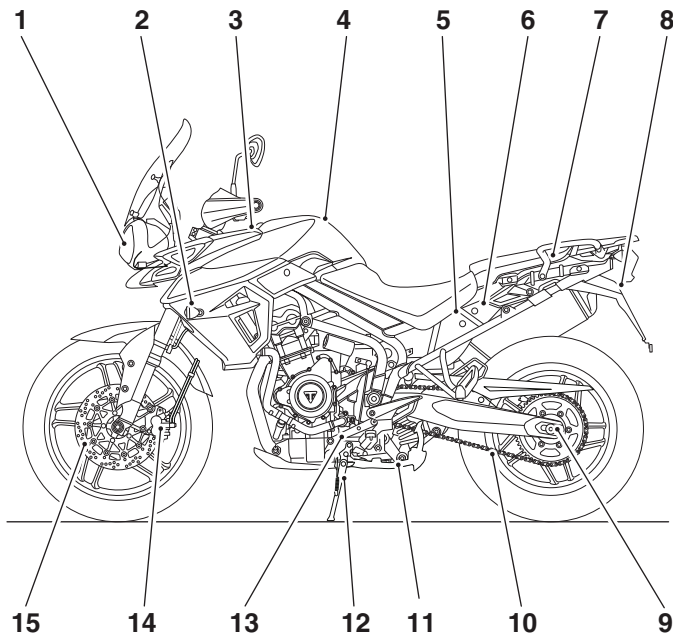

- | | |
|--|------------------------------|
| 1. Headlight | 8. Seat lock |
| 2. Front direction indicator | 9. Rear wheel adjuster |
| 3. Electrical accessory socket | 10. Drive chain |
| 4. Fuel tank and fuel filler cap | 11. Centre stand (if fitted) |
| 5. Battery and fuse boxes (under the rider seat) | 12. Side stand |
| 6. USB socket (under the passenger seat) | 13. Gear change pedal |
| 7. Tool kit/Accessory U-lock storage location (under the passenger seat) | 14. Front brake caliper |
| | 15. Front brake disc |

Tiger 800 XR Models (continued)

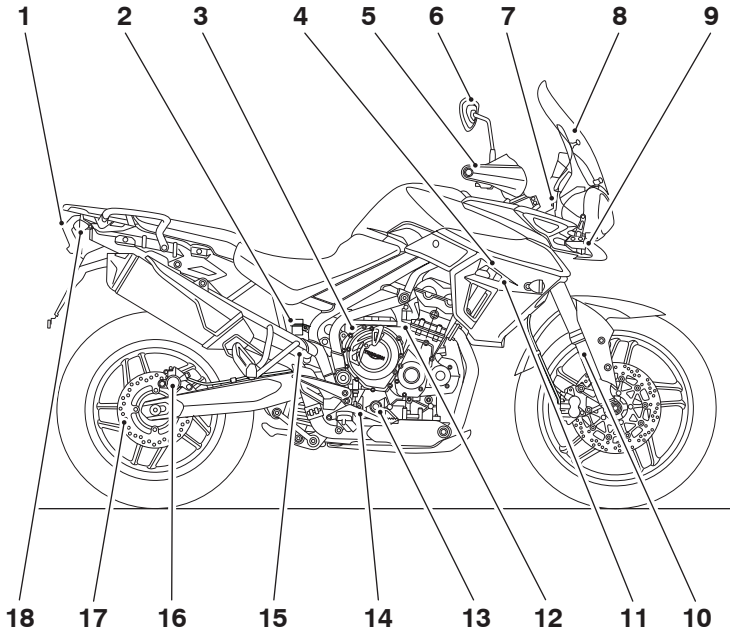

- | | |
|-------------------------------|---|
| 1. Rear light | 11. Radiator/Coolant pressure cap |
| 2. Rear brake fluid reservoir | 12. Clutch cable |
| 3. Oil filler cap | 13. Engine oil level sight glass |
| 4. Coolant expansion tank | 14. Rear brake pedal |
| 5. Handguards (if fitted) | 15. Rear suspension spring preload adjuster |
| 6. Mirror | 16. Rear brake caliper |
| 7. Headlight adjuster | 17. Rear brake disc |
| 8. Windscreen | 18. Rear direction indicator |
| 9. Fog light (if fitted) | |
| 10. Front fork | |

Parts Identification

Tiger 800 XC Models

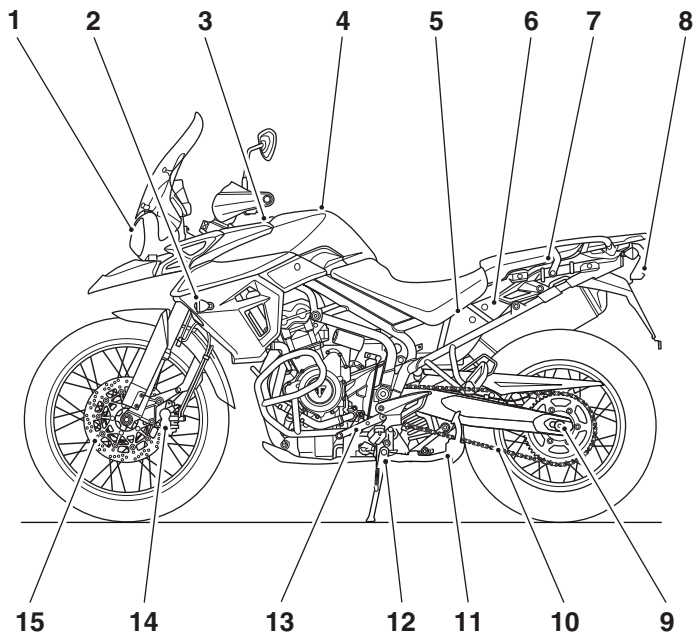

- | | |
|--|------------------------------|
| 1. Headlight | 8. Seat lock |
| 2. Front direction indicator | 9. Rear wheel adjuster |
| 3. Electrical accessory socket | 10. Drive chain |
| 4. Fuel tank and fuel filler cap | 11. Centre stand (if fitted) |
| 5. Battery and fuse boxes (under the rider's seat) | 12. Side stand |
| 6. USB socket (under the passenger's seat) | 13. Gear change pedal |
| 7. Tool kit/Accessory U-lock storage location (under the passenger's seat) | 14. Front brake caliper |
| | 15. Front brake disc |

Tiger 800 XC Models (continued)

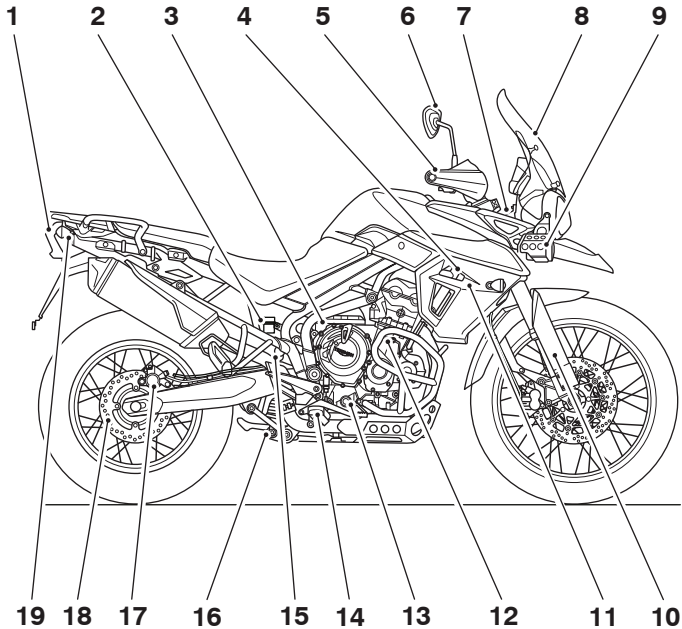

- | | |
|-------------------------------|--|
| 1. Rear light | 11. Radiator/Coolant pressure cap |
| 2. Rear brake fluid reservoir | 12. Clutch cable |
| 3. Oil filler cap | 13. Engine oil level sight glass |
| 4. Coolant expansion tank | 14. Rear brake pedal |
| 5. Handguards | 15. Rear suspension preload adjuster |
| 6. Mirror | 16. Rear suspension rebound damping adjuster |
| 7. Headlight adjuster | 17. Rear brake caliper |
| 8. Windscreen | 18. Rear brake disc |
| 9. Fog light (if fitted) | 19. Rear direction indicator |
| 10. Front fork | |

Parts Identification

Tiger 800 XR Only

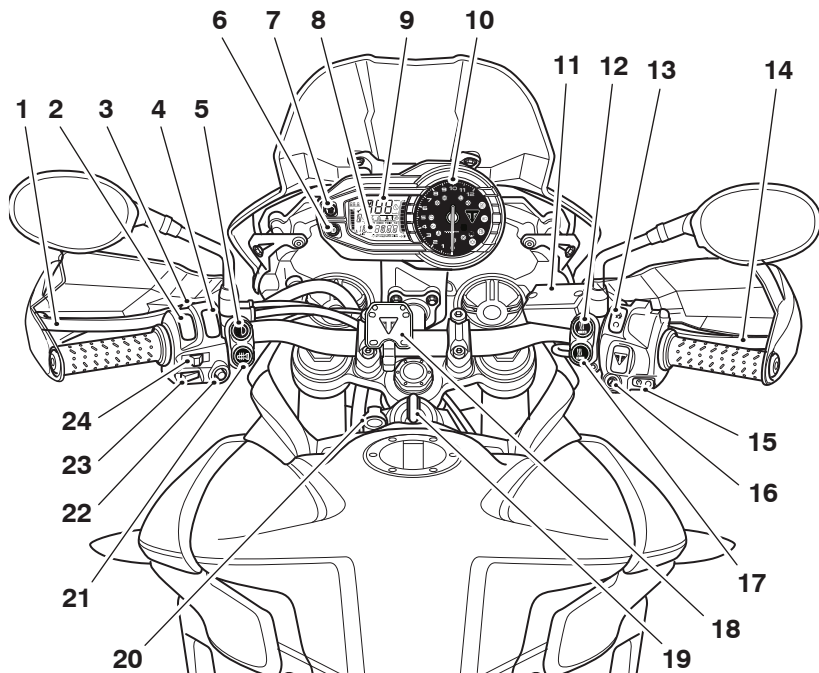

- | | |
|--|---|
| 1. Clutch lever | 14. Front brake lever |
| 2. Headlight dip switch | 15. Starter button |
| 3. Passing button | 16. Hazard warning light button |
| 4. Instrument SCROLL button | 17. Passenger's heated seat switch (if fitted) |
| 5. Fog lights switch (if fitted) | 18. Satellite navigation mounting bracket (if fitted) |
| 6. MODE/TRIP button | 19. Ignition switch |
| 7. HOME button | 20. Electrical accessory socket |
| 8. Trip computer display | 21. Heated grips switch (if fitted) |
| 9. Speedometer | 22. Instrument SET button |
| 10. Tachometer | 23. Horn button |
| 11. Front brake fluid reservoir | 24. Direction indicator switch |
| 12. Rider's heated seat switch (if fitted) | |
| 13. Engine stop switch | |

All Models except Tiger 800 XR

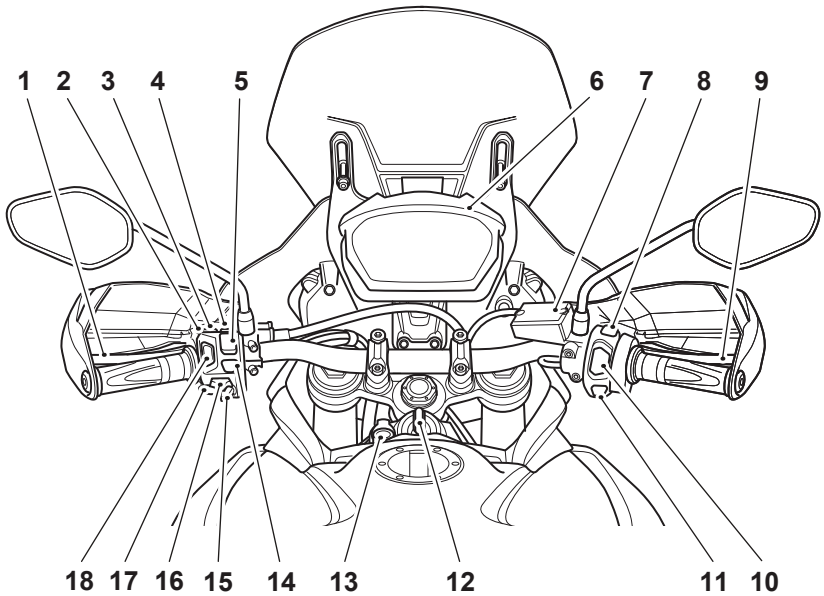

ckec

- | | |
|------------------------------------|--|
| 1. Clutch lever | 10. Engine start/stop button |
| 2. Headlight dip switch | 11. HOME button |
| 3. Heated seats switch (if fitted) | 12. Ignition switch |
| 4. Fog lights switch (if fitted) | 13. Electrical accessory socket |
| 5. Cruise control adjust switch | 14. MODE button |
| 6. TFT instrument display | 15. Joystick button |
| 7. Front brake fluid reservoir | 16. Direction indicator switch |
| 8. Hazard warning light button | 17. Horn button |
| 9. Front brake lever | 18. Daytime Running Lights (DRL) (if fitted) |

SERIAL NUMBERS

Vehicle Identification Number (VIN)

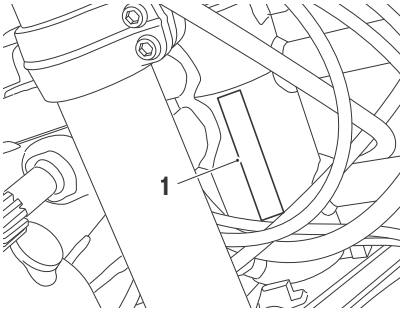

1. Vehicle identification number

The Vehicle Identification Number (VIN) is stamped into the steering head area of the frame. It is also displayed on a label attached to the left hand side of the headstock.

Record the vehicle identification number in the space provided below.

Engine Serial Number

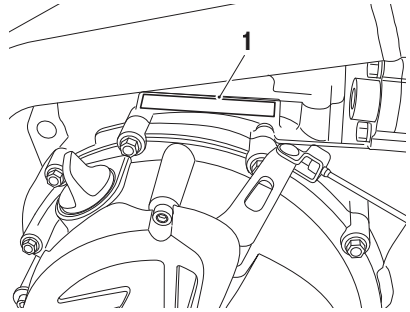

1. Engine serial number

The engine serial number is stamped on the engine crankcase, immediately above the clutch cover.

Record the engine serial number in the space provided below.

INSTRUMENTS

Instrument Displays Overview

There are two types of instrument displays fitted to specific motorcycle models.

All Models except Tiger 800 XR

All models except for Tiger 800 XR are fitted with a full colour Thin Film Transistor (TFT) digital instrument display.

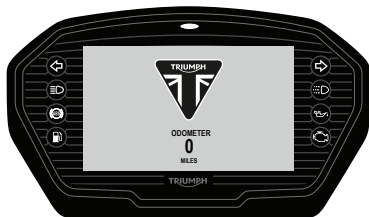

Thin Film Transistor (TFT) Instrument Display

For more information on the TFT instrument display and its operation, see page **24**.

Tiger 800 XR Models Only

Only Tiger 800 XR models are fitted with a Liquid Crystal Display (LCD) instrument display.

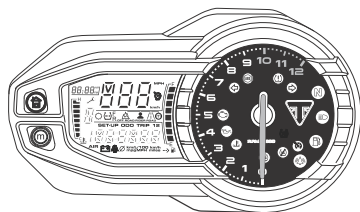

Liquid Crystal Display (LCD) Instrument Display

For more information on the LCD instrument display and its operation, see page **55**.

Instruments

Thin Film Transistor (TFT) Instrument Display

Table of Contents

Instrument Panel Layout.....	25
TFT Display Navigation.....	26
TFT Themes and Styles.....	26
Warning Lights.....	26
Speedometer and Odometer.....	32
Tachometer.....	32
Gear Position Display.....	32
Fuel Gauge.....	33
Service Interval Announcement.....	33
Ambient Air Temperature.....	33
Riding Modes.....	34
Riding Mode Selection.....	35
Information Tray.....	37
Main Menu.....	42
Instrument Panel Position Adjustment.....	53

Instrument Panel Layout

The TFT instrument display is fitted on all models except Tiger 800 XR. Not all instrument features are available on all models.

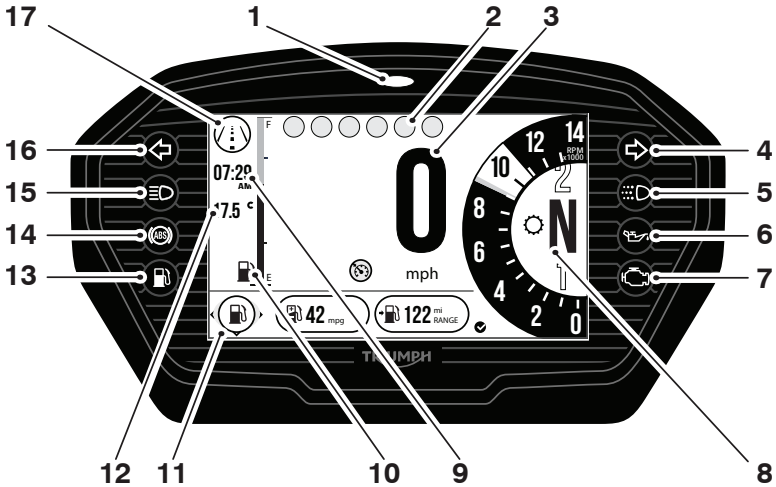

- | | |
|---|----------------------------------|
| 1. Alarm/immobiliser status indicator light (alarm is an accessory kit) | 8. Gear position symbol |
| 2. Warning lights | 9. Clock |
| 3. Speedometer | 10. Fuel gauge |
| 4. Right hand indicator | 11. Information tray |
| 5. Daytime Running Light (DRL) (if fitted) | 12. Ambient air temperature |
| 6. Oil pressure warning light | 13. Fuel level low warning light |
| 7. Engine management Malfunction Indicator Light (MIL) | 14. ABS warning light |
| | 15. High beam warning light |
| | 16. Left hand indicator |
| | 17. Current riding mode |

Instruments

TFT Display Navigation

The table below describes the instrument icons and buttons used to navigate through the instrument menus described in this handbook.



Home button (right hand switch housing).



Mode button (left hand switch housing).



Joystick left/right or up/down.



Joystick Centre (press).



Selection arrow (right shown).



Information Tray - left/right scroll via joystick.



Information Tray - up/down scroll via joystick.



Option available within the Information Tray - scroll via joystick up/down.



Short press (press and release) via joystick centre.



Long press (press and hold) via joystick centre.



Reset current feature. (only available with joystick long press).

TFT Themes and Styles

There is the option to change the style of the instrument display.

Depending on the motorcycle model, there are either one or two themes. Each theme has three different styles to select from.

To select a theme or style, see page **49**.

Styles can also be selected through the Style Options tray, see page **41**.

Theme 1, Style 1 is used for visual recognition throughout this owner's handbook.

Theme 1

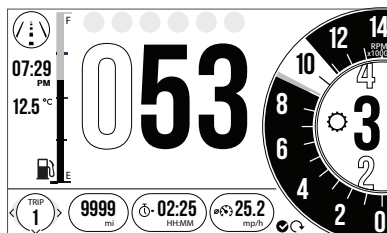

Theme 1 Style 1

Warning Lights

Note:

- **When the ignition is switched on, the instrument warning lights will illuminate for 1.5 seconds and will then go off (except those which remain on until the engine starts, as described in the following pages).**

For additional warning and information messages, see page **38**.

Engine Management System Malfunction Indicator Light (MIL)



The Malfunction Indicator Light (MIL) for the engine management system illuminates when the ignition is switched ON (to indicate that it is working) but should not become illuminated when the engine is running.

If the MIL becomes illuminated when the engine is running, this indicates that a fault has occurred in one or more of the systems controlled by the engine management system. In such circumstances, the engine management system will switch to 'limp-home' mode so that the journey may be completed, if the fault is not so severe that the engine will not run.

Warning

Reduce speed and do not continue to ride for longer than is necessary with the MIL illuminated. The fault may adversely affect engine performance, exhaust emissions and fuel consumption.

Reduced engine performance could cause a dangerous riding condition, leading to loss of control and an accident.

Contact an authorised Triumph dealer as soon as possible to have the fault checked and rectified.

Note:

- If the MIL flashes when the ignition is switched ON contact an authorised Triumph dealer as soon as possible to have the situation rectified. In these circumstances the engine will not start.

Low Oil Pressure Warning Light



With the engine running, if the engine oil pressure becomes dangerously low, the low oil pressure warning light will illuminate.

Caution

Stop the engine immediately if the low oil pressure warning light illuminates. Do not restart the engine until the fault has been rectified.

Severe engine damage will result from running the engine when the low oil pressure warning light is illuminated.

Note:

- The low oil pressure warning light will illuminate if the ignition is switched ON without running the engine.

Low Fuel Warning Light



The low fuel warning light will illuminate when there are approximately 4 litres of fuel remaining in the tank.

Instruments

Immobiliser/Alarm Indicator Light

This Triumph motorcycle is fitted with an engine immobiliser which is activated when the ignition is switched off.

Without Alarm Fitted

When the ignition is switched off, the immobiliser light will flash on and off for 24 hours to show that the engine immobiliser is on. When the ignition is switched on, the immobiliser and the indicator light will be off.

If the indicator light remains on it indicates that the immobiliser has a malfunction that requires investigation. Contact an authorised Triumph dealer as soon as possible to have the fault checked and rectified.

With Alarm Fitted

The immobiliser/alarm light will only illuminate when the conditions described in the genuine Triumph accessory alarm instructions are met.

ABS (Anti-Lock Brake System) Warning Light



When the ignition is switched on, it is normal that the ABS warning light will flash on and off. The light will continue to flash after engine start-up until the motorcycle first reaches a speed exceeding 6 mph (10 km/h) when it will go off.

Note:

- **Traction control will not function if there is a malfunction with the ABS. The warning lights for the ABS, traction control and the MIL will be illuminated.**

The warning light should not illuminate again until the engine is restarted unless there is a fault, or the ABS is switched off - the warning light will remain illuminated.

If the warning light becomes illuminated at any other time while riding it indicates that the ABS has a malfunction that requires investigation.

Warning

If the ABS is not functioning, the brake system will continue to function as a non-ABS equipped brake system. Do not continue to ride for longer than is necessary with the warning light illuminated. Contact an authorised Triumph dealer as soon as possible to have the fault checked and rectified. In this situation braking too hard will cause the wheels to lock resulting in loss of motorcycle control and an accident.

Traction Control (TC) Indicator Light



The TC indicator light is used to indicate that the traction control system is active and is working to limit rear wheel slip during periods of hard acceleration or under wet or slippery road conditions.

Warning

If the traction control is not functioning, care must be taken when accelerating and cornering on wet/slippery road surfaces to avoid rear wheel spin. Do not continue to ride for longer than is necessary with the Engine Management System Malfunction Indicator Light (MIL) and traction control warning lights illuminated. Contact an authorised Triumph dealer as soon as possible to have the fault checked.

Hard acceleration and cornering in this situation may cause the rear wheel to spin resulting in loss of motorcycle control and an accident.

TC Indicator Light Operation:

TC Switched On:

- Under normal riding conditions the indicator light will remain off.
- The indicator light will flash rapidly when the traction control system is working to limit rear wheel slip during periods of hard acceleration or under wet or slippery road conditions.

TC Switched Off:

The indicator light will not illuminate. Instead the TC disabled warning light will be illuminated (see page 29).

Note:

- **Traction control will not function if there is a malfunction with the ABS system. The warning lights for the ABS, traction control and the MIL will be illuminated.**

Traction Control (TC) Disabled Warning Light



The TC disabled warning light should not illuminate unless traction control is switched off or there is a malfunction.

If the warning light becomes illuminated at any other time while riding, it indicates that the traction control system has a malfunction that requires investigation.

Cruise Control Light



The cruise control can only be activated when the motorcycle is travelling at a speed between 19 to 100 mph (30 to 160 km/h) and is in 3rd gear or higher. When activated, the cruise control light will be illuminated (see page 90).

Warning

Cruise control must only be used where you can ride safely at a steady speed.

Cruise control should not be used when riding in heavy traffic, on roads with sharp/blind bends or when they are slippery.

Using cruise control in heavy traffic, on roads with sharp/blind bends or when they are slippery, may result in loss of motorcycle control and an accident.

Instruments

Direction Indicators



When the indicator switch is turned to the left or right, the indicator warning light will flash on and off at the same speed as the direction indicators.

Hazard Warning Lights

To turn the hazard warning lights on or off, press and release the hazard warning light switch.

The ignition must be switched ON for the hazard warning lights to function.

The hazard warning lights will remain on if the ignition is switched off, until the hazard warning light switch is pressed again.

High Beam Button



When the high beam button is pressed the high beam will be switched on. Each press of the button will swap between dip and high beam.

Note:

- **If daytime running lights are fitted to the motorcycle, the high beam button has additional functionality.**

If the DRL switch is in the daytime running lights position, then press and hold the high beam button to turn the high beam on. It will remain on as long as the button is held in and will turn off as soon as the button is released.

Note:

- **A lighting on/off switch is not fitted to this model. The rear light and licence plate light all function automatically when the ignition is turned to the ON position.**
- **The headlight will function when the ignition switch is turned to the ON position. The headlight will go off while pressing the starter button until the engine starts.**

Daytime Running Lights (DRL) Warning Light (if fitted)



When the ignition is switched ON and the daytime running lights switch is set to DAYTIME RUNNING LIGHTS, the daytime running lights warning light will illuminate.

The daytime running lights and low beam headlights are operated manually using a switch on the left hand switch housing, see page **82**.

Warning

Do not ride for longer than necessary in poor ambient light conditions with the Daytime Running Lights (DRL) in use.

Riding with the Daytime Running Lights when dark, in tunnels or where poor ambient light is apparent may reduce the riders vision or dazzle other road users.

Dazzling other road users or reduced vision in low ambient light levels may result in loss of motorcycle control and an accident.

Note:

- During daylight hours the Daytime Running Lights improve the motorcycles visibility to other road users.
- Low beam headlights must be used in any other conditions unless the road conditions allow for high beam headlights to be used.

Tyre Pressure Monitoring System (TPMS) Warning Light (if fitted)

Warning

Stop the motorcycle if the Tyre Pressure Monitoring System (TPMS) warning light illuminates red.

Do not ride the motorcycle until the tyres have been checked and the tyre pressures are at their recommended pressure when cold.

Note:

- The Tyre Pressure Monitoring System (TPMS) is available as an accessory option on some models.



The TPMS warning light will only illuminate red when the front or rear tyre pressure is below the recommended pressure, or no signal is received. It will not illuminate if the tyre is over inflated. For more information, see page 94.

When the warning light is illuminated, the TPMS symbol indicating which is the deflated tyre and its pressure will automatically be visible in the display area.

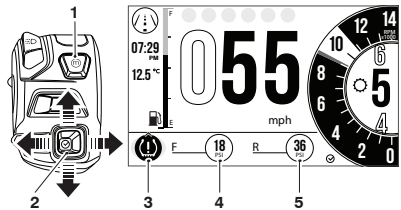

1. Mode button
2. Joystick control
3. TPMS light
4. Front tyre indicator
5. Rear tyre indicator

The tyre pressure at which the warning light illuminates is temperature compensated to 20°C but the numeric pressure display associated with it is not, see page 169. Even if the numeric display seems at or close to the standard tyre pressure when the warning light is on, a low tyre pressure is indicated and a puncture is the most likely cause.

Instruments

Speedometer and Odometer

The speedometer indicates the road speed of the motorcycle.

The odometer shows the total distance that the motorcycle has travelled.

Tachometer

⚠ Caution

Never allow engine speed to enter the red zone as severe engine damage may result.

The tachometer shows the engine speed in revolutions per minute - rpm (r/min). At the end of the tachometer range there is the red zone.

Engine speeds in the red zone are above maximum recommended engine speed and are also above the range for best performance.

Gear Position Display

The gear position display indicates which gear (one to six) has been engaged. When the transmission is in neutral (no gear selected), the display will show N.

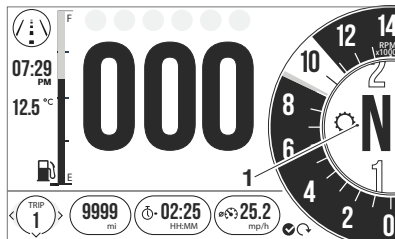

1. Gear position display (neutral position shown)

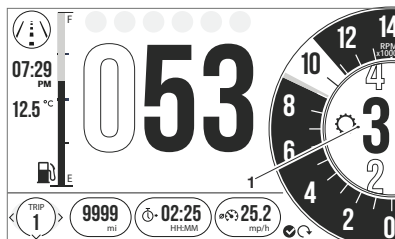

1. Gear position display (third gear shown)

Fuel Gauge

The fuel gauge indicates the amount of fuel in the tank.

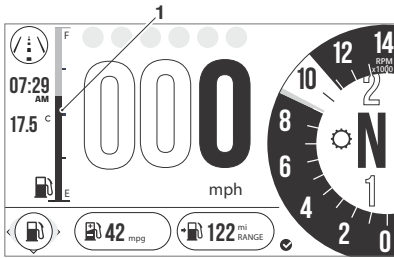

1. Fuel gauge

With the ignition switched on, a filled line indicates the fuel remaining in the fuel tank.

Note:

- **The fuel gauge colours may vary depending on the theme or style chosen.**

The gauge markings indicate intermediate fuel levels between E (empty) and F (full).

The low fuel warning light will illuminate when approximately 3.5 litres of fuel is remaining in the tank and you should refuel at the earliest opportunity.

The range to empty and instantaneous fuel consumption will be also shown in the information tray. Press the joystick centre to acknowledge and hide the low fuel warning.

After refuelling, the fuel gauge and range to empty information will be updated only while riding the motorcycle. Depending on the riding style, updating could take up to five minutes.

Service Interval Announcement



The service interval announcement shows the total distance or time that the motorcycle has remaining before a service is required. When the remaining distance is 0 miles (0 km), or the remaining time is 0 days, the service symbol will remain on until the service has been carried out and the system has been reset by your authorised Triumph dealer.

If the service is overdue then OVERDUE will be shown and the service symbol will be shown in the information tray.

When the service has been carried out by your authorised Triumph dealer, the system will be reset.

The distance to the next service or OVERDUE message will also be shown on the instrument start up screen when the ignition is turned on.

The service symbol will also be shown if a fault has occurred and the ABS and/or MIL warning lights are illuminated. Contact an authorised Triumph dealer as soon as possible to have the fault checked and rectified.

Ambient Air Temperature

The ambient air temperature is displayed as either °C or °F.

When the motorcycle is stationary the heat of the engine may affect the accuracy of the ambient temperature display.

Once the motorcycle starts moving the display will return to normal after a short time.

To change the temperature from °C or °F see page 51.

Instruments

Frost Symbol



The frost symbol will illuminate if the ambient air temperature is 4°C (39°F) or lower.

The frost symbol will remain illuminated until the temperature rises to 6°C (42°F).

An alert will also be displayed in the information tray.



CAUTION: LOW AIR TEMPERATURE
RISK OF SURFACE ICE
1/3 warnings



ACKNOWLEDGE

When the motorcycle is stationary the heat of the engine may affect the accuracy of the ambient temperature display.

Once the motorcycle starts moving the display will return to normal after a short time.

Warning

Black ice (sometimes called clear ice) can form at temperatures several degrees above freezing (0°C (32°F)), especially on bridges and in shaded areas.

Always take extra care when the temperatures are low and reduce speed in potentially hazardous driving conditions such as bad weather.

Excess speed, hard acceleration, heavy braking or hard cornering when roads are slippery may result in loss of motorcycle control and an accident.

Riding Modes











The riding modes allow adjustment of the throttle response (MAP), Anti-lock Brake System (ABS) and Traction Control (TC) settings to suit differing road conditions and rider preferences.

Riding modes can be conveniently selected using the MODE button and joystick located on the left hand switch housing, whilst the motorcycle is stationary or moving, see page 35.

Note:

- Up to six riding modes are available depending on the motorcycle model's specification.

If a riding mode is edited (other than the RIDER mode), the icon will change as shown below.

Default Icon	Rider Edited Icon	Description
	-	RIDER
		RAIN
		ROAD
		SPORT
		OFF-ROAD
		OFF-ROAD PRO

Each riding mode is adjustable. For more information, see page 44.

Availability of the ABS, MAP and TC setting options vary between models.

Riding Mode Selection

Warning

The selection of riding modes whilst the motorcycle is in motion requires the rider to allow the motorcycle to coast (motorcycle moving, engine running, throttle closed, clutch lever pulled in and no brakes applied) for a brief period of time.

Riding mode selection whilst the motorcycle is in motion should only be attempted:

- At low speed
- In traffic-free areas
- On straight and level roads or surfaces
- In good road and weather conditions
- Where it is safe to allow the motorcycle to briefly coast.

Riding mode selection whilst the motorcycle is in motion **MUST NOT** be attempted:

- At high speeds
- Whilst riding in traffic
- During cornering or on winding roads or surfaces
- On steeply inclined roads or surfaces
- In poor road/weather conditions
- Where it is unsafe to allow the motorcycle to coast.

Failure to observe this important warning may lead to loss of motorcycle control and an accident.

Warning

If ABS and/or Traction Control (TC) has been disabled in the Main Menu as described on Bike Set Up - ABS for ABS and/or page **46** for TC then settings saved for all riding modes will be overridden.

ABS and/or TC will remain off regardless of your riding mode selection until they have been re-enabled or, the ignition has been switched off then on again, or the MODE button is held in to return to the default ROAD mode (which enables ABS and/or TC when the motorcycle is next stationary).

If the ABS is disabled, the brake system will function as a non-ABS equipped braking system. In this situation braking too hard will cause the wheels to lock, and may result in loss of motorcycle control and an accident.

If the traction control is disabled, the motorcycle will handle as normal but without traction control. In this situation accelerating too hard on wet/slippery road surfaces may cause the rear wheel to slip, and may result in loss of motorcycle control and an accident.

Instruments

Warning

After selecting a riding mode, operate the motorcycle in an area free from traffic to gain familiarity with the new settings.

Do not loan your motorcycle to anyone as they may change the riding mode settings from the one you are familiar with, causing loss of motorcycle control and an accident.

Note:

- The riding mode will default to ROAD when the ignition is switched ON, if the OFF-ROAD, OFF-ROAD PRO or RIDER mode was active the last time the ignition was switched OFF with ABS or TC set to OFF-ROAD or OFF in either of those modes.
- Otherwise, the last selected riding mode will be remembered and activated when the ignition is switched ON.
- If the mode icons are not visible when the ignition switch is in the ON position, make sure that the engine stop switch is in the RUN position.

The current riding mode is shown in the upper left of the display screen.

To select a riding mode:

- Press and release the MODE button on the left hand switch housing to activate the riding mode selection tray at the bottom of the display screen.
- The currently active riding mode icon is highlighted with a blue background.

To change the selected riding mode:

- Either push the joystick left or right, or repeatedly press the MODE button until the required mode is in the centre of the display screen, highlighted with an arrow above it.
- A brief press of the joystick centre will select the required riding mode, and the icon in the upper left of the display screen will change.

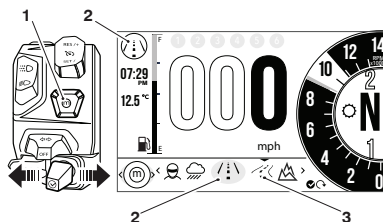

1. **MODE button**
2. **Current riding mode**
3. **New riding mode**

- Push the joystick left/right or press the MODE button to scroll through the riding mode options in the following order:
 - RIDER
 - RAIN
 - ROAD
 - SPORT
 - OFF-ROAD
 - OFF-ROAD PRO.

The selected mode is activated once the following conditions for switching modes have been met:

Motorcycle Stationary - Engine Off

- The ignition is switched ON
- The engine stop switch is in the RUN position.

Motorcycle Stationary - Engine Running

- Neutral gear is selected or the clutch is pulled in.

Motorcycle in Motion

Within 30 seconds of selecting a riding mode the rider must carry out the following simultaneously:

- Close the throttle
- Pull the clutch in
- Make sure that the brakes are not engaged (allow the motorcycle to coast).

Note:

- **It is not possible to switch into or out of OFF-ROAD, OFF-ROAD PRO or RIDER modes whilst the motorcycle is in motion, if the ABS or TC settings are set to OFF-ROAD or OFF in either of those modes.**
- **In this case, the motorcycle must be brought to a stop before the riding mode change can take place.**

If a riding mode change is not completed, the icon will alternate between the previous riding mode and the newly selected riding mode until the change is complete or it is cancelled.

The riding mode selection is now complete and normal riding can be resumed.

Information Tray

Warning

When the motorcycle is in motion, only attempt to switch between the information tray modes or reset the fuel information under the following conditions:

- At low speed
- In traffic free areas
- On straight and level roads or surfaces
- In good road and weather conditions.

Failure to observe this important warning could lead to loss of motorcycle control and an accident.

The information tray appears at the bottom of the display screen and allows easy access to different motorcycle status information.

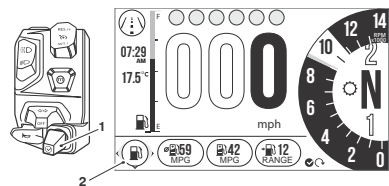

1. Joystick control
2. Information tray

To view the different information tray items, push the joystick left/right until the required information tray item is shown.

Instruments

Note:

- To access the information tray, the warning messages must first be acknowledged, see page 38.

The information tray contains the following information tray items:

- Warnings and Information Messages, see page 38
- Trip Meter, see page 39
- Fuel Information, see page 39
- Tyre Pressure Monitoring System (TPMS) (if fitted), see page 40
- Odometer, see page 40
- Service Interval Announcement, see page 40
- Screen Contrast, see page 41
- Style Options, see page 41
- Coolant Temperature, see page 41

Different information tray items can be shown or hidden from the information tray. For further information, refer to page 50.

Warnings

Any warnings and information messages are shown in the Warnings tray. An example is shown below.

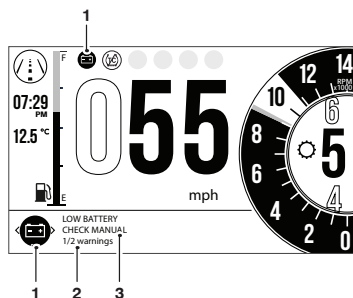

1. Low battery warning
2. Warning counter
3. Warning description

To view the warnings:

- Push the joystick left/right to scroll through the options until the warning review is shown.
- Push the joystick down/up to review each warning (if more than one). The warning counter will show the amount of warnings that are present.
- Push the joystick left/right to return to the information tray.

Low Battery Warning

If items such as the heated grips and accessory fog lights are fitted and are on with the engine at idle, over a period of time, the battery voltage may drop below a predetermined voltage and a warning message will be shown in the Warnings tray.

Trip Meter

There are two trip meters that can be accessed and reset in the information tray.



Trip Meter Information Tray

To view a specific trip meter:

- Push the joystick left/right to scroll through the information tray items until Trip 1 meter is shown.
- Select TRIP 1 or TRIP 2 by pushing the joystick down/up.

Note:

- **TRIP 2 meter can be shown or hidden from the information tray. For more information, see page 48.**

To reset a trip meter:

- Select the trip meter to be reset.
- Press and hold the joystick centre for more than one second.
- The trip meter will then be reset.

The trip meter can also be reset from the Main menu, see page 47.

Fuel Status Information

The Fuel Status information tray shows fuel consumption information.

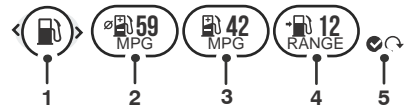

1. Fuel information light
2. Average fuel consumption
3. Instantaneous fuel consumption
4. Range to empty
5. Reset

Fuel Information Light

This light illuminates when the fuel level warning light is activated.

Average Fuel Consumption

This is an indication of the average fuel consumption. After being reset the display will show dashes until 0.1 miles/km has been covered.

Instantaneous Fuel Consumption

An indication of the fuel consumption at an instant in time. If the motorcycle is stationary, --.- will be shown in the display area.

Range to Empty

This is an indication of the predicted distance that can be travelled on the remaining fuel in the tank.

Reset

To reset the average fuel consumption, press and hold the joystick centre.

Instruments

Note:

- After refuelling, the fuel gauge and range to empty information will be updated only while riding the motorcycle. Depending on the riding style, updating could take up to five minutes.

Tyre Pressure Monitoring System (TPMS) (if fitted)

The Tyre Pressure Monitoring System (TPMS) information tray item shows the front and rear tyre pressures and the TPMS warning light. For more information on TPMS, see page 94.

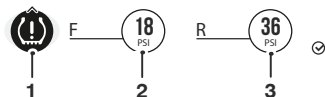

1. TPMS warning light
2. Front tyre pressure display
3. Rear tyre pressure display

TPMS Warning Light

The warning light will only illuminate when the front or rear tyre pressure is below the recommended pressure. It will not illuminate if the tyre is over inflated.

Warning

Stop the motorcycle if the Tyre Pressure Monitoring System (TPMS) warning light illuminates.

Do not ride the motorcycle until the tyres have been checked and the tyre pressures are at their recommended pressure when cold.

Front Tyre Pressure Display

This shows the current front tyre pressure.

Rear Tyre Pressure Display

This shows the current rear tyre pressure.

Odometer

The odometer shows the total distance that the motorcycle has travelled.

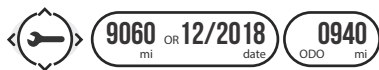

Odometer Information Tray

Service Interval Announcement

The Service Interval Announcement information tray shows the service symbol, the distance/days remaining before the next service and the current odometer reading.

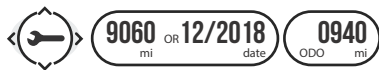

Service Interval Announcement Information Tray

For more information on service interval announcements, see page 33.

Screen Contrast

The Screen Contrast information tray item allows the display screen contrast to be adjusted.

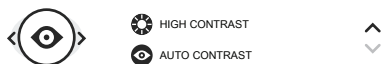

Screen Contrast Information Tray

There are two options available:

- **HIGH CONTRAST** - This option locks the display screen to the white background version of each display screen style for maximum visibility.
- **AUTO CONTRAST** - This option uses the instrument light sensor to adjust the contrast to the most suitable setting. In bright sunlight, low brightness settings will be overridden to make sure that the instruments can be viewed at all times.

To select an option:

- Push the joystick down/up to select either the **HIGH CONTRAST** or **AUTO CONTRAST** option and press the joystick centre to confirm.

If the rider defined brightness setting is suitable this will be used, see page 50.

Note:

- **Do not cover the light sensor on the display screen as this will stop the screen contrast from working correctly.**

Style Options

The Style Options information tray item allows a different style to be applied to the display screen.

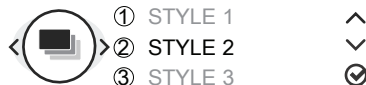

Style Options Information Tray (Style 2 Selected)

To change the display screen style:

- Push the joystick down/up to select the required style and then press the joystick centre to confirm.

Coolant Temperature

The Coolant Temperature information tray item indicates the temperature of the engine coolant.



Coolant Temperature Information Tray

When the engine is started from cold the display will show grey bars. As the temperature increases more bars in the display will be shown illuminated. When the engine is started from hot the display will show the relevant number of illuminated bars, dependant on engine temperature.

The range is between C (cold) and H (hot) on the display.

Instruments

With the engine running, if the engine coolant temperature becomes dangerously high, the high coolant temperature warning light on the display will be illuminated and the gauge will be shown in the information tray.

 **Caution**

Stop the engine immediately if the high coolant temperature warning light illuminates. Do not restart the engine until the fault has been rectified.

Severe engine damage will result from running the engine when the high coolant temperature warning light is illuminated.

Main Menu

To access the Main menu:

- The motorcycle must be stationary with the ignition switched on.
- Press the HOME button on the right handlebar switch housing.
- Scroll the Main menu by pushing the joystick down/up until the required option is selected and then press the joystick centre to confirm.

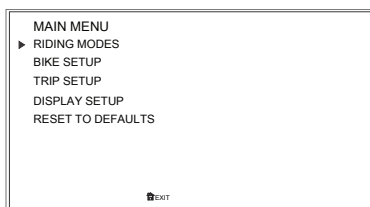

Main Menu Screen

The Main menu allows access to the following options:

Riding Modes

This menu allows configuration of the riding modes. For more information, see page 44.

Bike Set Up

This menu allows configuration of the different features of the motorcycle. For more information, see page 45.

Trip Set Up

This menu allows configuration of Trip 1 and Trip 2. For more information, see page 47.

Display Set Up

This menu allows configuration of the display options. For more information, see page 49.

Reset to Defaults

This menu allows all instrument settings to be returned to the default setting. For more information, see page 53.

Riding Modes Menu

The Riding Modes menu allows configuration of the riding modes.

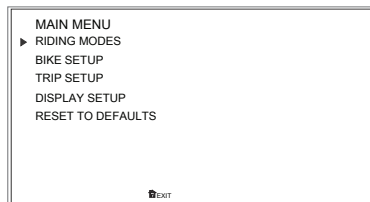

To access the Riding Modes menu:

- Press the HOME button to display the Main menu.
- Push the joystick down and then press the joystick centre to select RIDING MODES.

The riding mode options include:

- Rider
- Rain
- Road
- Sport
- Off-Road
- Off-Road Pro
- Reset To Defaults.

Note:

- **Riding modes are model specific. Not all riding modes will be available.**

Riding Modes

To change the riding modes settings:

- From the Riding Modes menu, push the joystick down/up to select a specific riding mode and press the joystick centre to confirm.

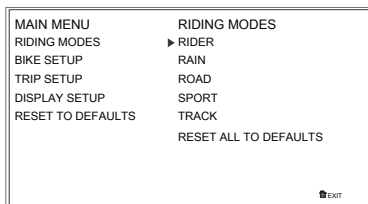

- Push the joystick down/up until the required setting option is selected and press the joystick centre to confirm.

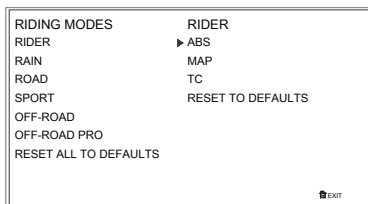

- Push the joystick down/up until the required option is selected and press the joystick centre to confirm.

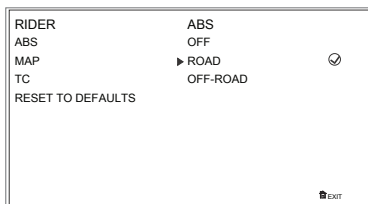







Instruments

Riding Mode Configuration

The riding modes available depends on the motorcycle model. Not all riding modes will be shown.

Refer to the following table for the ABS, MAP and TC options available for each riding mode.

Riding Mode						
	RIDER 	RAIN 	ROAD 	SPORT 	OFF-ROAD 	OFF-ROAD PRO 
ABS (Anti-lock Braking System)						
Road	●	●	●	●	⊘	
Off-Road	○	⊘	⊘	⊘	●	○
Off	○	Via Menu	Via Menu	Via Menu	○	●
MAP (Throttle Response)						
Rain	○	●	○	⊘	○	○
Road	●	○	●	○	○	○
Sport	○	⊘	○	●	○	○
Off-Road	○	⊘	⊘	⊘	●	●
TC (Traction Control)						
Rain	○	●	○	⊘	⊘	⊘
Road	●	○	●	○	⊘	⊘
Sport	○	⊘	○	●	○	⊘
Off-Road	○	⊘	⊘	⊘	●	○
Off	○	Via Menu	Via Menu	Via Menu	○	●
Key						
●		Standard (Factory Default Setting)				
○		Selectable Option				
⊘		Option Not Available				

Bike Set Up Menu

The Bike Set Up menu allows configuration of the different features of the motorcycle.

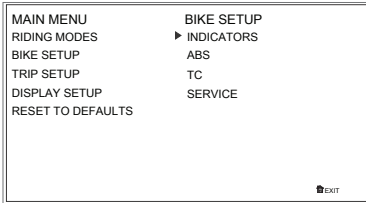

To access the Bike Set Up menu:

- Press the HOME button to display the Main menu.
- Push the joystick down and then press the joystick centre to select BIKE SET UP.

The options available are:

- Direction Indicators
- Anti-Lock Braking System (ABS)
- Traction Control (TC)
- Service.

Bike Set Up - Direction Indicators

The direction indicators can be set to Auto Basic, Auto Advanced or Manual mode.

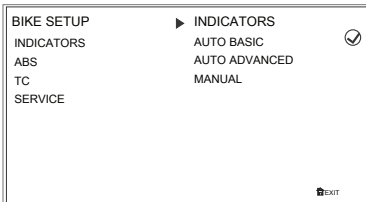

Selecting a Direction Indicators Mode

To select the required direction indicators mode:

- From the Bike Set Up menu, push the joystick down to select INDICATORS and press the joystick centre to confirm.
- Push the joystick down/up to scroll between AUTO BASIC, AUTO ADVANCED and MANUAL.
 - **Auto Basic** - The self-cancelling function is on. The direction indicators will activate for eight seconds and an additional 65 metres.
 - **Auto Advanced** - The self-cancelling function is on. A short press activates the direction indicators for three flashes. A longer press activates the direction indicators for eight seconds and an additional 65 metres.
 - **Manual** - The self-cancelling function is off. The direction indicators must be manually cancelled using the direction indicator switch.
- Press the joystick centre to confirm the required selection.
- The display will then return to the Bike Set Up menu.

Instruments

Bike Set Up - ABS

It is possible to temporarily disable the ABS. The ABS cannot be permanently disabled, it will be automatically enabled when the ignition is turned off and then on again, or if the default riding mode is activated by a long press of the MODE button.

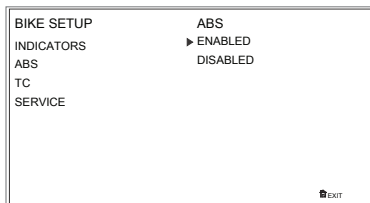

To select the required option:

- From the Bike Set Up menu, push the joystick down to select ABS and press the joystick centre to confirm.
- Push the joystick down/up to scroll between ENABLED and DISABLED.
- Press the joystick centre to confirm the required selection.
- The display will then return to the Bike Set Up menu.

Bike Set Up - Traction Control (TC)

It is possible to temporarily disable the traction control system. The traction control cannot be permanently disabled, it will be automatically enabled when the ignition is turned off and then on again, or if the default riding mode is activated by a long press of the MODE button.

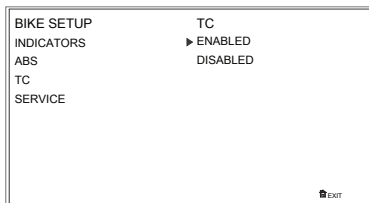

To select the required option:

- From the Bike Set Up menu, push the joystick down to select TC and press the joystick centre to confirm.
- Push the joystick down/up to scroll between ENABLED and DISABLED.
- Press the joystick centre to select the required option.

The display will then return to the BIKE SET UP display.

Bike Set Up - Service

The service interval is set to a distance and/or time period.

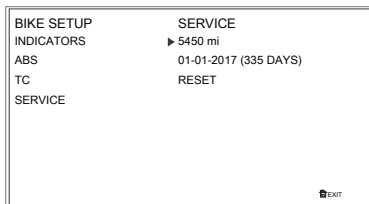

To review the service interval:

- From the Bike Set Up menu, push the joystick down to select SERVICE and press the joystick centre to confirm.
- Press the joystick centre to display the SERVICE information.
- Selecting RESET allows you to reset the standard time and distance, and also any custom times and distances.
- The display will then return to the Bike Set Up menu.

Trip Setup

The Trip Set Up menu allows configuration of the trip meters. Each trip meter can be configured to be reset either manually or automatically. The setup procedure is the same for both trip meters.

To access the Trip Set Up menu:

- Press the HOME button to display the Main menu.
- Push the joystick down and then press the joystick centre to select TRIP SET UP.

The options available are:

- TRIP 1 RESET
- TRIP 2 RESET
- TRIP 2 DISPLAY

Trip Setup - Manual Reset

Manual reset of the trip meters will only reset the selected trip meter when the rider chooses to do so.

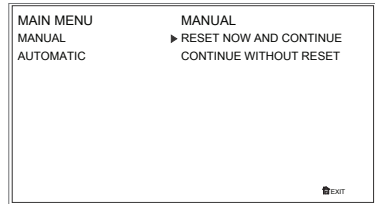

To set the trip meter to reset manually:

- Push the HOME button to display the MAIN MENU.
- Push the joystick down and then press the joystick centre to select TRIP SETUP.
- Push the joystick down and then press the joystick centre to select TRIP 1 RESET or TRIP 2 RESET.
- Push the joystick centre to select MANUAL.

There are two options:

- RESET NOW AND CONTINUE - Resets all trip meter data in the relevant trip meter, and the trip meter will only reset when manually done so by the rider.
 - CONTINUE WITHOUT RESET - The trip meter will not be reset. The trip meter will only reset when manually done so by the rider.
- Press the joystick centre to confirm the selection and return to the previous menu.

Instruments

Trip Setup - Automatic Reset

Automatic reset will reset each trip meter after the ignition has been switched off for a set time.

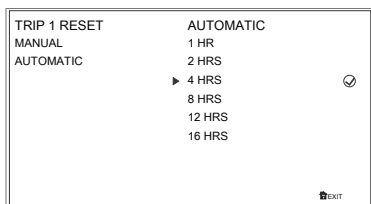

To set the trip meters to reset automatically:

- Push the HOME button to display the MAIN MENU.
- Push the joystick down and then press the joystick centre to select TRIP SETUP.
- Push the joystick down/up and then press the joystick centre to select TRIP 1 RESET or TRIP 2 RESET.
- Push the joystick down/up and select AUTOMATIC and then press the joystick centre.
- Push the joystick down/up to select the timer setting and press the joystick centre to confirm the required time limit. The required time limit is then stored in the trip memory.

When the ignition is turned off, the trip meter is set to zero when the time period has elapsed.

The following table shows two examples of the automatic trip reset functionality.

Ignition Turned Off	Selected Time Delay	Trip Meter Resets to Zero
10:30 hrs	4 HRS	14:30 hrs
18:00 hrs	16 HRS	10:00 hrs (next day)

Trip 2 Enable/Disable

Trip 2 meter can be enabled or disabled. If Trip 2 is disabled it will no longer be shown in the information tray.

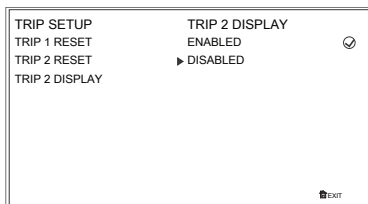

To enable or disable the Trip 2 meter:

- Push the MODE button to display the MAIN MENU.
- Push the joystick down to select TRIP SET UP.
- Push the joystick centre to display the TRIP SET UP menu.
- Push the joystick down/up to scroll to the TRIP 2 DISPLAY and press the joystick centre.
- Push the joystick down/up to scroll between ENABLED and DISABLED and press the joystick centre.

Display Set Up Menu

The Display Set Up menu allows configuration of the different display screen options.

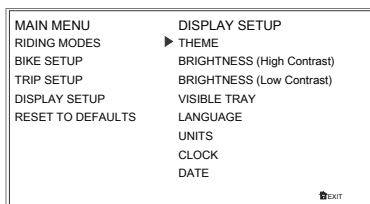

To access the Display Set Up menu:

- Press the HOME button to display the Main menu.
- Push the joystick down and then press the joystick centre to select DISPLAY SET UP.

The following options are available:

- Styles and Themes
- Brightness
- Visible Tray
- Shift Indicator
- Language
- Set Units
- Set Clock
- Set Date.

Display Set Up - Themes and Styles

Note:

- Themes are only available on Tiger 800 XRT and Tiger 800 XCA.

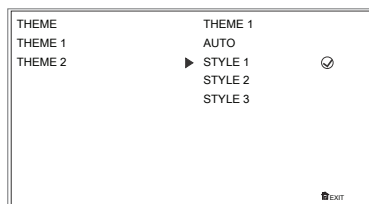

Theme and Style Menu Example

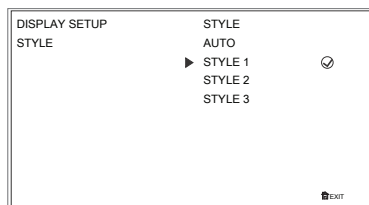

Style Menu Example

To select a style or theme:

- From the Display Set Up menu, push the joystick down to select the THEME (if fitted) and STYLES menu.
 - **Tiger 800 XRT and Tiger 800 XCA:** Push the joystick down/up to scroll between the themes.
 - Press the joystick centre to confirm the selected theme.
 - **All Models:** Push the joystick down/up to scroll between the styles.

Instruments

- Press the joystick centre to confirm the selected style.
- The new theme or style will be saved. Press the HOME button to exit.

Note:

- **Selecting AUTO will prevent a style tray from being displayed. The style is changed with riding modes.**

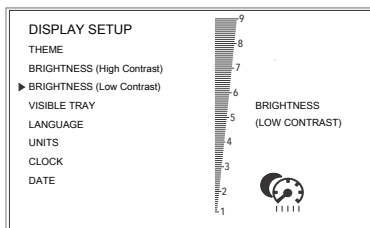

Display Set Up - Brightness

The brightness feature allows the screen's brightness contrast to be changed for day time and night time riding.



BRIGHTNESS (LOW CONTRAST) Shown

There are two brightness options to choose:

- High contrast (day time )
- Low contrast (night time )

To change the brightness level:

- From the Display Set Up menu, push the joystick down to select BRIGHTNESS and press the joystick centre to confirm.
- Push the joystick down to select BRIGHTNESS (High Contrast) or BRIGHTNESS (Low Contrast) menu.
- Press the joystick centre to select the required menu.
- Push the joystick down/up to adjust the brightness.
- Press the joystick centre to confirm the required level of brightness.
- Press the HOME button to return to the main display.

Note:

- **In bright sunlight, low brightness settings will be overridden to make sure that the instruments can be viewed at all times.**

Display Set Up - Visible Tray

The Visible Tray feature allows the selection of required information tray items to be shown in the information tray.

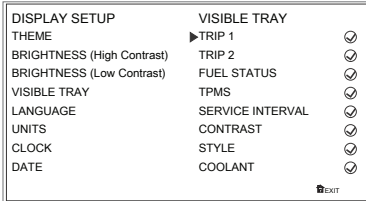

To select the Visible Tray menu:

- From the Display Set Up menu, push the joystick down to select VISIBLE TRAY and press the joystick centre to confirm.
- Push the joystick down/up until the required information tray item is selected.
- Press the joystick centre to select/deselect the information tray item.

An information tray item with a tick next to it will be shown in the tray. An information tray item without a tick next to it will not be shown in the tray.

Display Set Up - Language

There are several different languages that can be selected to be shown in the display screen.

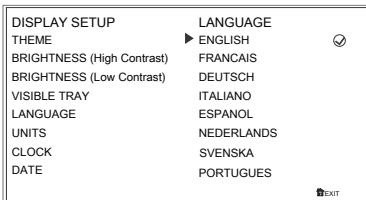

To select a different language:

- From the Display Set Up menu, push the joystick down to select LANGUAGE and press the joystick centre to confirm.
- Push the joystick down/up until the required language is selected.
- Press the joystick centre to select/deselect the required language.

Display Set Up - Set Units

There are different units of measurement options that can be shown in the display screen.

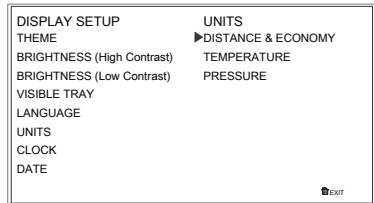

To select the units of measurement required:

- From the Display Set Up menu, push the joystick down to select SET UNITS and press the joystick centre to confirm.
- Push the joystick down/up to select the required unit; DISTANCE and ECONOMY, TEMPERATURE or PRESSURE.
- Push the joystick down/up to select the required unit of measurement from the following options:
 - DISTANCE and ECONOMY:**
 - MILES and MPG (UK)
 - MILES and MPG (US)
 - KM and L/100KM
 - KM and KM/L

Instruments

- **TEMPERATURE:**
 - °C
 - °F
 - **PRESSURE:**
 - PSI
 - BAR
 - KPa
- Press the joystick centre to confirm.

Display Set Up - Set Clock

This function allows the adjustment of the clock.

To set the clock:

- From the Display Set Up menu, push the joystick down to select SET CLOCK and press the joystick centre to confirm.
- Push the joystick down/up to select between either 12 HR or 24 HR clock and press the joystick centre to confirm selection. The clock will display in either 12 or 24 hour format. Once the clock format is set the display will return to the SET CLOCK menu.

To set the time, push the joystick down/up to select HOUR or MINUTE.

To adjust the hour setting:

- Select HOUR on the display and press the joystick centre, a tick will appear next to HOUR and the hour display will flash as shown below.
- Push the joystick down/up to set the hour and press the joystick centre to confirm.

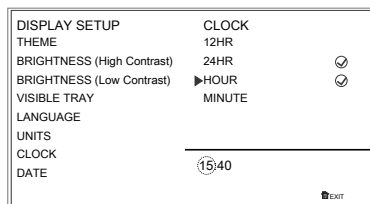

To adjust the minute setting:

- Select MINUTE on the display and press the joystick centre, a tick will appear next to MINUTE and the minute display will flash as shown below.
- Push the joystick down/up to set the minute and press the joystick centre to confirm.

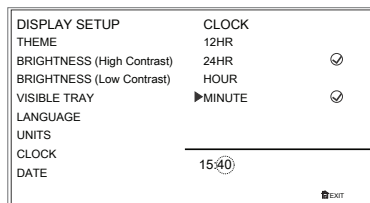

Reset to Defaults

This function allows the main menu display items to be reset to the default setting.

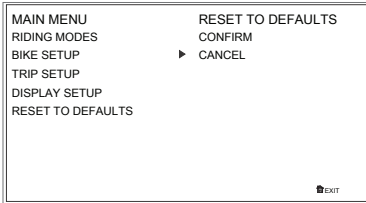

To reset the Main menu display items:

- From the Main menu, push the joystick down and select **RESET TO DEFAULTS**.
- Press the joystick centre to confirm.
- Pushing the joystick down/up, select **CONFIRM** or **CANCEL** from the Reset to Defaults menu, and press the joystick centre to confirm.
- **Confirm** - The following main menu settings and data will be reset to the factory default values - Riding Modes, Indicator Set Up, Trip Computers, Visible Trays, Language, ABS, Traction Control, Style, and Display Brightness.
- **Cancel** - The main menu settings and data will remain unchanged and the display will return to the previous level.

Instrument Panel Position Adjustment

Warning

Operation of the motorcycle with an incorrectly adjusted instrument panel is dangerous.

An incorrectly adjusted instrument panel will result in loss of instrument vision when riding and may cause a distraction leading to loss of control of the motorcycle and an accident.

Always adjust the instrument panel to provide sufficient vision of the instruments before riding the motorcycle.

Warning

Never attempt to clean or adjust the instrument panel while riding the motorcycle. Removal of the rider's hands from the handlebars while riding the motorcycle will diminish the ability of the rider to maintain control of the motorcycle.

Attempting to clean or adjust the instrument panel while riding the motorcycle may result in loss of control of the motorcycle and an accident.

Only attempt to clean or adjust the instrument panel while stationary.

Instruments

⚠ Caution

Do not press directly onto the instrument panel display screen.

Only adjust the position of the instrument panel using the adjustment handle.

Pressing directly on the instrument panel display screen may damage the instrument panel.

The instrument panel can be adjusted to allow for improved visibility of the display screen.

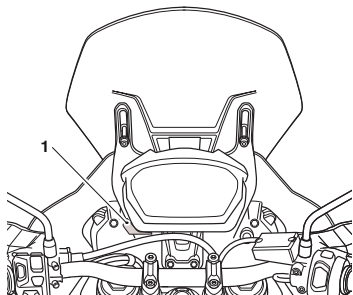

1. Adjustment handle

To adjust the instrument panel:

- Push the adjustment handle away from the instrument panel.
- Position the instrument panel to allow an unobstructed view of the display screen.
- Pull the adjustment handle towards the instrument panel and back into its original position.

Note:

- **Moderate force using the thumb and finger is required to adjust the position of the instrument panel.**

Liquid Crystal Display (LCD) Instrument Display

Table of Contents

Instrument Panel Layout.....	56
Warning Lights.....	57
Instruments.....	62

Instruments

Instrument Panel Layout

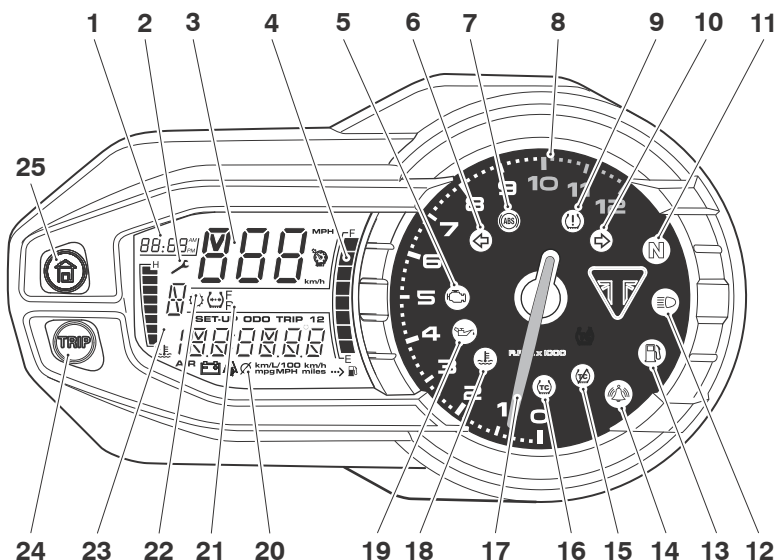

1. Clock
2. Service interval indicator
3. Speedometer
4. Fuel gauge
5. Engine management malfunction indicator light
6. Left hand direction indicator light
7. ABS warning light
8. Tachometer red zone
9. Tyre pressure warning light (if Tyre Pressure Monitoring System (TPMS) is fitted)
10. Right hand direction indicator light
11. Neutral indicator light
12. High beam indicator light
13. Low fuel level indicator light
14. Alarm/immobiliser status indicator light (alarm is an accessory kit)
15. Traction control disabled warning light
16. Traction control indicator light
17. Tachometer
18. High coolant temperature warning light
19. Low oil pressure warning light
20. Frost symbol
21. Tyre pressure display (if Tyre Pressure Monitoring System (TPMS) is fitted)
22. Selected gear
23. Coolant temperature gauge
24. TRIP button
25. HOME button

Warning Lights

When the ignition is switched on, the instrument warning lights will illuminate for 1.5 seconds and will then go off (except those which remain on until the engine starts, as described in the following pages).

Direction Indicators



When the indicator switch is turned to the left or right, the indicator warning light will flash on and off at the same speed as the direction indicators.

Neutral



The neutral warning light indicates when the transmission is in neutral (no gear selected). The warning light will illuminate when the transmission is in neutral with the ignition switch in the ON position.

High Beam Light



When the ignition is switched ON and the headlight dip switch is set to HIGH BEAM, the high beam warning light will illuminate.

Low Fuel Light



The low fuel indicator will illuminate when there are approximately 4.0 litres of fuel remaining in the tank.

ABS (Anti-Lock Brake System) Warning Light



When the ignition switch is turned to the ON position, it is normal that the ABS warning light will flash on and off. The light will continue to flash after engine start-up until the motorcycle first reaches a speed exceeding 6 mph (10 km/h) when it will go off.

Note:

- **Traction control will not function if there is a malfunction with the ABS system.**
- **The warning lights for the ABS, traction control and the MIL will be illuminated.**

The warning light should not illuminate again until the engine is restarted unless there is a fault, or:

- ABS is switched off - the warning light will remain illuminated.
- ABS is set to Off Road - the warning light will flash slowly.

If the warning light becomes illuminated at any other time while riding it indicates that the ABS has a malfunction that requires investigation.

Warning

If the ABS is not functioning, the brake system will continue to function as a non-ABS braking system. Do not continue to ride for longer than is necessary with the warning light illuminated. Contact an authorised Triumph dealer as soon as possible to have the fault checked and rectified. In this situation braking too hard will cause the wheels to lock resulting in loss of motorcycle control and an accident.

For details on how to select different ABS settings see:

- ABS Disable on page 68.

Immobiliser/Alarm Indicator Light



This Triumph motorcycle is fitted with an engine immobiliser which is activated when the ignition switch is turned to the OFF position.

Without Alarm Fitted

When the ignition switch is turned to the OFF position, the immobiliser/alarm light will flash on and off for 24 hours to show that the engine immobiliser is on. When the ignition switch is turned to the ON position the immobiliser and the indicator light will be off.

If the indicator light remains on it indicates that the immobiliser has a malfunction that requires investigation. Contact an authorised Triumph dealer as soon as possible to have the fault checked and rectified.

With Alarm Fitted

The immobiliser/alarm light will only illuminate when the conditions described in the genuine Triumph accessory alarm instructions are met.

Traction Control (TC) Indicator Light



The TC indicator light is used to indicate that the traction control system is active and is working to limit rear wheel slip during periods of hard acceleration or under wet or slippery road conditions.

Warning

If the traction control is not functioning, care must be taken when accelerating and cornering on wet/slippy road surfaces to avoid rear wheel spin. Do not continue to ride for longer than is necessary with the Engine Management System Malfunction Indicator Light (MIL) and traction control warning lights illuminated. Contact an authorised Triumph dealer as soon as possible to have the fault checked.

Hard acceleration and cornering in this situation may cause the rear wheel to spin resulting in loss of motorcycle control and an accident.

TC Indicator Light Operation:

TC Switched On:

- Under normal riding conditions the indicator light will remain off.
- The indicator light will flash rapidly when the traction control system is working to limit rear wheel slip during periods of hard acceleration or under wet or slippery road conditions.

TC Switched Off:

The indicator light will not illuminate. Instead the TC disabled warning light will be illuminated (see page 59).

Note:

- **Traction control will not function if there is a malfunction with the ABS system. The warning lights for the ABS, traction control and the MIL will be illuminated.**

Traction Control (TC) Disabled Warning Light



The TC disabled warning light should not illuminate unless traction control is switched off or there is a malfunction.

If the warning light becomes illuminated at any other time while riding, it indicates that the traction control system has a malfunction that requires investigation.

Engine Management System Malfunction Indicator Light (MIL)



The Malfunction Indicator Light (MIL) for the engine management system illuminates when the ignition is switched ON (to indicate that it is working) but should not become illuminated when the engine is running.

If the MIL becomes illuminated when the engine is running, this indicates that a fault has occurred in one or more of the systems controlled by the engine management system. In such circumstances, the engine management system will switch to 'limp-home' mode so that the journey may be completed, if the fault is not so severe that the engine will not run.

Warning

Reduce speed and do not continue to ride for longer than is necessary with the MIL illuminated. The fault may adversely affect engine performance, exhaust emissions and fuel consumption.

Reduced engine performance could cause a dangerous riding condition, leading to loss of control and an accident.

Contact an authorised Triumph dealer as soon as possible to have the fault checked and rectified.

Instruments

Note:

- If the MIL flashes when the ignition is switched ON contact an authorised Triumph dealer as soon as possible to have the situation rectified. In these circumstances the engine will not start.

High Coolant Temperature Warning Light



With the engine running, if the engine coolant temperature becomes dangerously high, the high coolant temperature warning light will illuminate.

Caution

Stop the engine immediately if the high coolant temperature warning light illuminates. Do not restart the engine until the fault has been rectified.

Severe engine damage will result from running the engine when the high coolant temperature warning light is illuminated.

Caution

Stop the engine immediately if the low oil pressure warning light illuminates. Do not restart the engine until the fault has been rectified.

Severe engine damage will result from running the engine when the low oil pressure warning light is illuminated.

Note:

- The low oil pressure warning light will illuminate if the ignition is switched ON without running the engine.

Tyre Pressure Warning Light (if fitted)



The tyre pressure warning light works in conjunction with the tyre pressure monitoring system (see page 61).

The warning light will only illuminate when the front or rear tyre pressure is below the recommended pressure. It will not illuminate if the tyre is over inflated.

Low Oil Pressure Warning Light



With the engine running, if the engine oil pressure becomes dangerously low, the low oil pressure warning light will illuminate.

When the warning light is illuminated, the TPMS symbol indicating which is the deflated tyre and its pressure will automatically be visible in the display area.

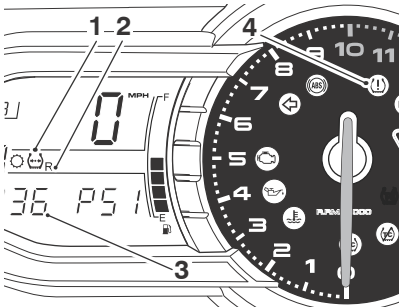

1. TPMS symbol
2. Rear tyre, identified
3. Tyre pressure
4. Tyre pressure warning light

The tyre pressure at which the warning light illuminates is temperature compensated to 20°C but the numeric pressure display associated with it is not (see page 167). Even if the numeric display seems at or close to the standard tyre pressure when the warning light is on, a low tyre pressure is indicated and a puncture is the most likely cause.

Warning

Stop the motorcycle if the tyre pressure warning light illuminates.

Do not ride the motorcycle until the tyres have been checked and the tyre pressures are at their recommended pressure when cold.

Frost Symbol



The frost symbol will illuminate if the ambient temperature is below 4°C (39°F) or lower.

The ambient air temperature is displayed for four seconds upon illumination of the frost symbol. The display will then revert back to the previous screen.

The frost symbol will remain illuminated until the temperature rises to 6°C (42°F).

The temperature display can be turned off by pressing either the SET or SCROLL buttons on the left hand switch housing. The previous screen will be displayed with the frost symbol illuminated until the temperature rises to 6°C (42°F).

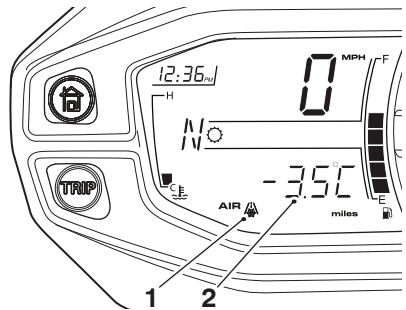

1. Frost symbol
2. Ambient air temperature

Instruments

Warning

Black ice (sometimes called clear ice) can form at temperatures several degrees above freezing (0°C (32°F)), especially on bridges and in shaded areas.

Always take extra care when the temperatures are low and reduce speed in potentially hazardous driving conditions such as bad weather.

Excess speed, hard acceleration, heavy braking or hard cornering when roads are slippery may result in loss of motorcycle control and an accident.

When the motorcycle is stationary the heat of the engine may affect the accuracy of the ambient temperature display.

Once the motorcycle starts moving the display will return to normal after a short time.

Low Battery Warning

If items such as the heated grips and accessory fog lights are fitted and are on with the engine at idle, over a period of time, the battery voltage may drop below a predetermined voltage and bAt Lo will be visible in the display screen.

The display will remain on until one of the following conditions is met:

- The charging system has charged the battery
- Either the SCROLL or SET buttons on the left hand switch housing has been pressed
- The ignition switch has been turned to the OFF position.

If necessary have the battery and charging system checked by your authorised Triumph dealer.

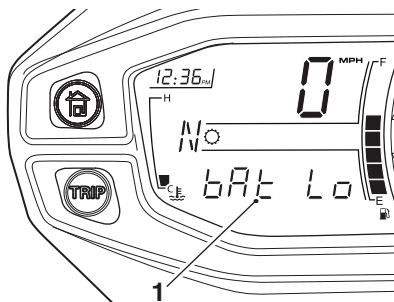

1. Display screen

Instruments

Speedometer and Odometer

The digital speedometer indicates the road speed of the motorcycle. The read-out displays the motorcycle road speed in increments of one mile (or kilometre) per hour.

The electronic odometer and two trip meters are available to view in the display screen. For details of the operation of the odometer and trip meters see page 65.

Tachometer

The tachometer shows the engine speed in revolutions per minute - rpm (r/min). At the end of the tachometer range there is the red zone. Engine rpm (r/min) in the red zone is above maximum recommended engine speed and is also above the range for best performance.

Caution

Never allow engine rpm to enter the red zone as severe engine damage may result.

Gear Position Display

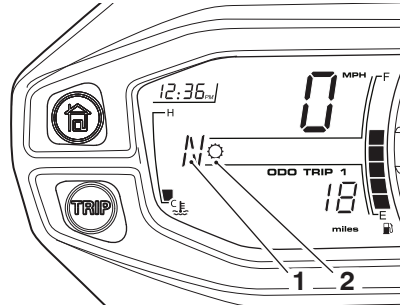

1. Gear position display (neutral position displayed)
2. Gear position symbol

The gear position display indicates which gear (one to six) has been engaged. When the transmission is in neutral (no gear selected), the display will show N.

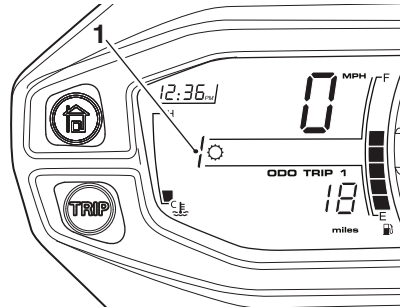

1. Gear position display (first gear shown)

Instruments

Coolant Temperature Gauge

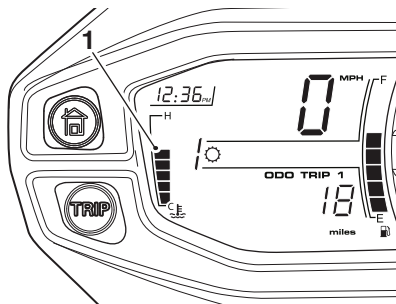

1. Coolant temperature gauge

The coolant temperature gauge indicates the temperature of the engine coolant.

When the ignition is switched on, all eight bars of the display will be shown. When the engine is started from cold the display will show one bar. As the temperature increases more bars in the display will be shown. When the engine is started from hot the display will show the relevant number of bars, dependant on engine temperature.

The normal temperature range is between four and six bars. If the coolant temperature becomes too high the display will show eight bars and will start to flash. The high coolant temperature light in the tachometer will also be illuminated.

Caution

Do not continue to run the engine if either of the high temperature warnings are displayed as severe engine damage may result.

Fuel Gauge

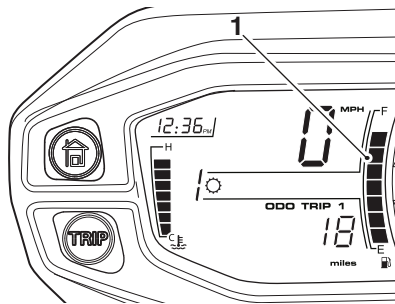

1. Fuel gauge

The fuel gauge indicates the amount of fuel in the tank.

With the ignition switched on, the number of bars shown in the display indicates the level of fuel.

When the fuel tank is full all eight bars are displayed and when empty, no bars are displayed. Other gauge markings indicate intermediate fuel levels between full and empty.

When two bars are displayed the low fuel warning light will illuminate, five seconds later the display screen will switch to the Range to Empty display (see page 66). This indicates there are approximately 4.0 litres of fuel remaining in the tank and you should refuel at the earliest opportunity.

After refuelling, the fuel gauge and range to empty information will be updated only while riding the motorcycle. Depending on the riding style, updating could take up to five minutes. If the display screen is changed so that the Range to Empty is no longer shown, this information may be displayed again through the Information Menu as described in page 66.

Service Interval Indicator

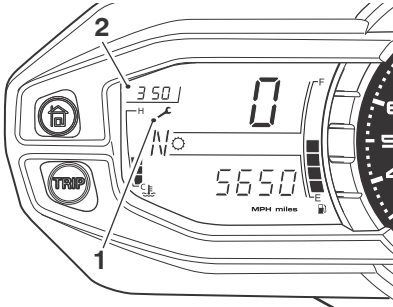

1. Service indicator
2. Remaining distance

When the ignition is switched on and the distance to the next service is 500 miles (800 km) or less, the display will briefly show the distance remaining before the next service. If the service is overdue, the distance will be displayed as a negative number.

When the service has been carried out by your authorised Triumph dealer, the system will be reset.

When the remaining distance is 0 miles (0 km) the service symbol will remain on until the service has been carried out and the system has been reset by your authorised Triumph dealer. If the service is overdue, the distance will be displayed as a negative number.

Trip Computer

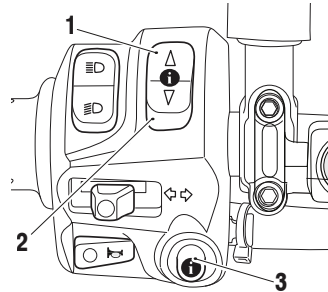

1. SCROLL button, up
2. SCROLL button, down
3. SET button

To access the trip computer information:

- Press and release the SET button on the left hand switch housing until the desired display is shown.
- The display will cycle through in the following order:
 - Trip Meter 1
 - Trip Meter 2
 - Information
 - Setup.

Instruments

Trip Meters

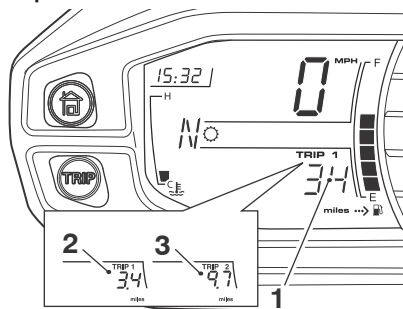

1. Trip meter display
2. Trip meter 1 display
3. Trip meter 2 display

To access the trip meters:

- Press and release the SET button on the left hand switch housing until the required trip meter is shown.
- Press and release the SCROLL button on the left hand switch housing.
- The display will show the journey distance. This is the total journey distance travelled since the trip meter was last reset to zero.

Trip Meter Reset

To reset either of the trip meters:

- Select and display the trip meter to be zeroed.
- Press and hold the SET button for two seconds. After two seconds, all items within the selected trip meter will reset to zero.

Information Menu

To access the information menu:

- Turn the ignition to the ON position.
- Press and release the SET button on the left hand switch housing until InFo appears in the display screen.

Note:

- **InFo will appear in the display screen for 0.5 seconds to indicate that the information menu has been selected. The display screen will then change to display one of the items listed below.**
- Press and release the SCROLL button on the left hand switch housing. The display will scroll through the information menu in the following order when pressing down on the SCROLL button (it will scroll through in the reverse order when pressing up on the SCROLL button):
 - Range to empty
 - Ambient air temperature
 - Odometer
 - Front tyre pressure (if TPMS is fitted and activated)
 - Rear tyre pressure (if TPMS is fitted and activated)
 - Instantaneous fuel consumption.

Each display provides the following information:

Range to Empty

This is an indication of the probable distance that can be travelled on the remaining fuel in the tank.

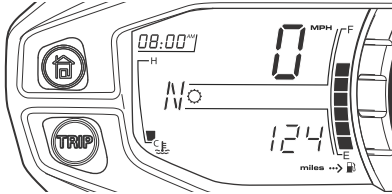

Range to Empty

Ambient Air Temperature

The current ambient air temperature is displayed in °C or °F.

To change the temperature from °C or °F, see page 74.

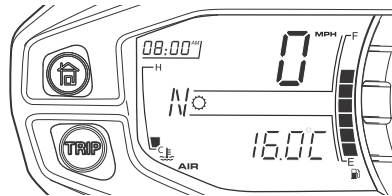

Ambient Air Temperature

Odometer

Shows the total distance that the motorcycle has travelled.

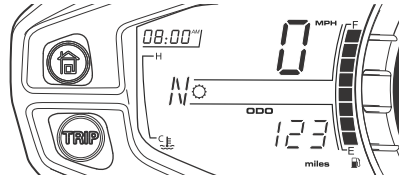

Odometer

Front and Rear Tyre Pressures (if TPMS is fitted and activated)

The front and rear tyre pressures are displayed.

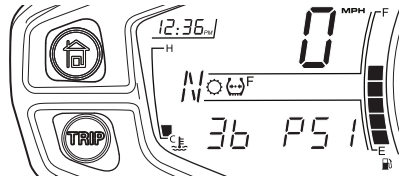

Front Tyre Pressure Shown

Instruments

Instantaneous Fuel Consumption

An indication of the fuel consumption at an instant in time. If the motorcycle is stationary, --- will be shown in the display area.

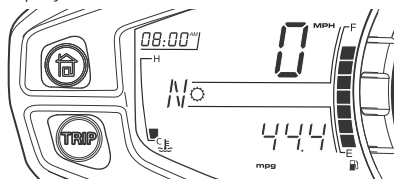

Instantaneous Fuel Consumption

Warning

When the motorcycle is in motion, only attempt to switch between the information and trip meter display modes or reset the trip meter under the following conditions:

- At low speed
- In traffic free areas
- On straight and level roads or surfaces
- In good road and weather conditions.

Failure to observe this important warning could lead to loss of motorcycle control and an accident.

To exit the information menu, press and release the SET button until the desired trip meter is displayed.

Setup Menu

To access the setup menu:

- Make sure the motorcycle is stationary and in neutral.
- Press and release the SET button on the left hand switch housing until SETUP is shown in the display screen.
- Press and release the SCROLL button until the chosen menu item is shown.
- Pressing the SET button allows the displayed menu item to be edited.

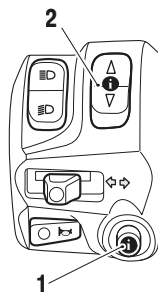

1. SET button
2. SCROLL button

The display will scroll through the menus when pressing down on the SCROLL button (it will scroll through in the reverse order when pressing up on the SCROLL button):

- t-SEt - Clock Adjustment
- Ind - Auto - Self-cancelling Direction Indicators
- SIA - Service Interval Announcement
- UnitS - Changing Units (imperial, metric or US).
- REtURn - Returns the instruments to the main display.
- ttc - Triumph Traction Control (TTC) settings
- AbS - Antilock Braking System (ABS) settings

Each menu item can be edited as follows:

Traction Control (TTC) Disable

It is possible to temporarily disable the TTC system. The TTC system cannot be permanently disabled, it will be automatically enabled when the ignition is turned off and then on again.

Warning

Do not attempt to adjust the traction control settings while the motorcycle is in motion as this may lead to loss of motorcycle control and an accident.

Warning

If the traction control is disabled, the motorcycle will handle as normal but without traction control. In this situation accelerating too hard on wet/slippery road surfaces may cause the rear wheel to slip, and may result in loss of motorcycle control and an accident.

To Disable the TTC

To access the traction control settings:

- With the motorcycle stationary and in neutral, turn the ignition to the ON position.
- Press and release the SET button on the left hand switch housing until SEtUP is shown in the display screen.
- Press and release the SCROLL button until ttc is shown.
- Press the SET button and On or OFF will be displayed.
- Press and release the SCROLL button until OFF is shown in the display screen.
- Pressing the SET button will disable the TTC system; OFF will be displayed for two seconds, and the TTC disabled warning light will be illuminated.
- Press the HOME button and trip 1 will be shown in the display screen.

Instruments

To Enable the TTC

To enable the TTC system again,:

- Repeat the TTC disable procedure and select On.
- Press the HOME button and trip 1 will be shown in the display screen.
- An alternative way to enable the TTC system is to turn the ignition off and on.

ABS Disable (Tiger XR Only)

It is possible to temporarily disable the ABS system. The ABS system cannot be permanently disabled, it will be automatically enabled when the ignition is turned off and then on again.

Warning

Do not attempt to adjust the ABS settings while the motorcycle is in motion as this may lead to loss of motorcycle control and an accident.

Warning

If the ABS is disabled, the brake system will function as a non-ABS braking system.

In this situation braking too hard will cause the wheels to lock, and may result in loss of motorcycle control and an accident.

To Disable the ABS

To access the ABS Disable function:

- With the motorcycle stationary and in neutral, turn the ignition to the ON position.
- Press and release the SET button on the left hand switch housing until SETUP is shown in the display screen.
- Press and release the SCROLL button until AbS is shown.
- Press the SET button and On or OFF will be displayed.
- Press and release the SCROLL button until OFF is shown in the display screen.
- Pressing the SET button will disable the ABS system; OFF will be displayed for two seconds, and the ABS warning light will be illuminated.
- Press the HOME button and trip 1 will be shown in the display screen.

Note:

- **With the ABS disabled, the traction control will still function (unless the traction control is also disabled).**

To Enable the ABS

To enable the ABS system again:

- Repeat the ABS disable procedure and select on.
- Press the HOME button and trip 1 will be shown in the display screen.
- An alternative way to enable the ABS is to turn the ignition off and on.

Clock Adjustment - t-SET

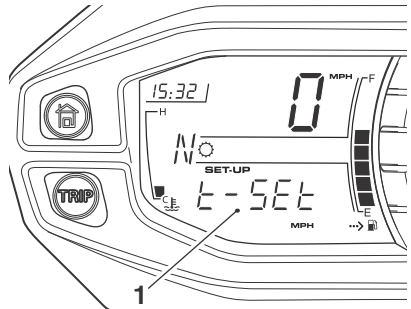

1. Time set

To reset the clock:

- With the motorcycle stationary and in neutral turn the ignition to the ON position.
- Press and release the SET button on the left hand switch housing until SETUP is shown in the display screen.
- Press and release the SCROLL button until t-SET is shown.
- Press the SET button again and either 24 Hr or 12 Hr clock will be shown.
- Press the SCROLL button to select the required clock display and then press the SET button. The hour display will start to flash and the word Hour is shown in the display screen.

Instruments

Note:

- The hour/minute display will increase when pressing up on the SCROLL button or decrease when pressing down on the SCROLL button.

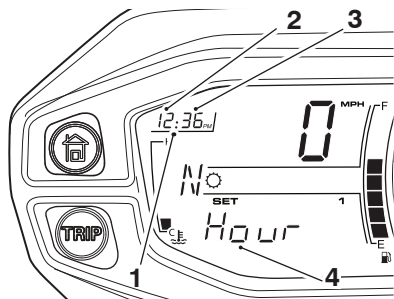

1. Clock display
2. Hours read-out
3. Minutes read-out
4. Display screen (Hour selected for adjustment)

To reset the hour display:

- Make sure that the hour display is still flashing and the word Hour is shown. Press the SCROLL button to change the setting. Each individual button press will change the setting by one digit. If the button is held, the display will continuously scroll through in single digit increments.
- When the correct hour display is shown, press the SET button. The minutes display will begin to flash and the word Min is visible in the display screen. The minutes display is adjusted in the same way as for the hours.
- Once both hours and minutes are correctly set, press the SET button to confirm and t-SET will be shown in the display screen.
- Press the SCROLL button until the display shows RETURN and press the SELECT button, the odometer in the trip 1 menu will be shown in the display screen.

Auto – Self-cancelling Direction Indicators – Ind

The motorcycle has a self-cancelling direction indicator function that can be disabled or enabled.

To disable or enable the self-cancelling function:

- With the motorcycle stationary and in neutral, press and release the SET button on the left hand switch housing until SETUP is shown in the display screen.
- Press and release the SCROLL button until Ind is shown in the display screen.
- Press and release the SET button and Auto or MANUAL will flash on and off.
- Press and release the SCROLL button to select Auto or MANUAL then press the SET button.
 - Auto – The self-cancelling function is on (see page 85).
 - MANUAL – The self-cancelling function is off. The direction indicators must be manually cancelled (see page 85).

To exit the Auto – Self-cancelling Direction Indicators menu:

- Press and release the SCROLL button until the display shows RETURN.
- Press the SELECT button. The trip 1 menu will be shown in the display screen.

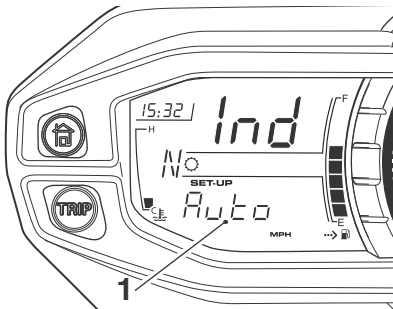

1. Auto selected

Instruments

Service Interval Announcement – SIA

Shows the total distance that the motorcycle has remaining before a service is required (see page 65).

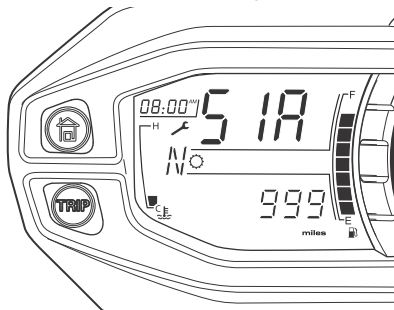

Service Interval Announcement Screen

Changing Units – UnitS (Imperial, US or Metric)

Units has four selectable display modes. Each display provides the following information:

mpg (Imperial gallons)

The speedometer and odometer will read in miles. The fuel consumption will be measured in imperial gallons.

mpg US (US gallons)

The speedometer and odometer will read in miles. The fuel consumption will be measured in US gallons.

L/100 km (Metric)

The speedometer and odometer will read in kilometres. The fuel consumption will be measured in litres of fuel per 100 km.

km/L (Metric)

The speedometer and odometer will read in kilometres. The fuel consumption will be measured in kilometres per litre of fuel.

Units Display

To access the units display:

- With the motorcycle stationary and in neutral, turn the ignition to the ON position.
- Press and release the SET button on the left hand switch housing until SETUP is shown in the display screen.
- Press and release the SCROLL button until UnitS is shown then press the SET button.

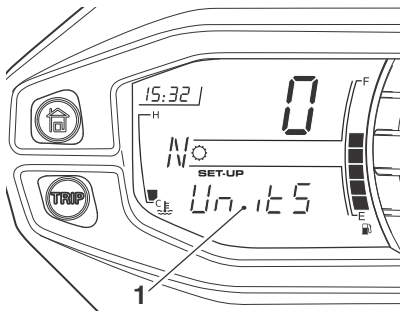

1. Display screen

- Press and release the SCROLL button until the required display is shown. The display will scroll through in the following order when pressing down on the SCROLL button (it will scroll through in the reverse order when pressing up on the SCROLL button):
 - mpg - Imperial gallons
 - mpg US - US gallons
 - L/100 km - Metric
 - km/L - Metric.

Tyre Pressure Units – (if TPMS is fitted)

Press the SET button and do not touch the SCROLL or SET buttons again until PSI or bAr is displayed. Press and release the SCROLL button until the desired tyre pressure units are visible.

Ambient Air Temperature Units

Press the SET button and wait until °C or °F is visible. Press and release the SCROLL button until the desired temperature unit is displayed. Press the SET button and wait until UnitS is displayed.

To exit, press the SCROLL button until the display shows REtURN and press the SET button. The trip 1 menu will be visible in the display screen.

Return

Returns the instruments to the main display.

GENERAL INFORMATION

Table of Contents

Hand Controls.....	78
Ignition.....	78
Engine Immobiliser.....	78
Ignition Switch/Steering Lock.....	78
Right Handlebar Switches.....	79
Right Handlebar Switches.....	80
Left Handlebar Switches.....	81
Left Handlebar Switches.....	85
Throttle Control.....	87
Brake and Clutch Lever Adjusters.....	88
ABS Options.....	89
Cruise Control.....	90
Activating Cruise Control.....	90
Adjusting the Set Speed While in Cruise Control.....	91
Deactivating Cruise Control.....	91
Resuming the Cruise Control Set Speed.....	92
Traction Control (TC).....	93
Traction Control Settings.....	93
Tyre Pressure Monitoring System (TPMS) (if fitted).....	94
Tyre Pressure Sensor Serial Number.....	95
TPMS Display.....	95
Fuel.....	97
Fuel Tank Cap.....	98
Filling the Fuel Tank.....	99
Handlebar Adjustment.....	100
Satellite Navigation Mounting Bracket (if fitted).....	101
Stands.....	102
Centre Stand (if fitted).....	102
Seats.....	103
Passenger Seat.....	103
Rider's Seat.....	104
Heated Seats (if fitted).....	105
Windscreen.....	107
Tool Kit and Owner's Handbook.....	108
Helmet Hook.....	108
Electrical Accessory Socket.....	109

General Information

Universal Serial Bus (USB) Socket.....	110
Luggage Systems.....	111
Triumph Accessory D-lock Storage.....	115
Running-In.....	116
Daily Safety Checks.....	117

General Information

Hand Controls

Ignition

Ignition Key

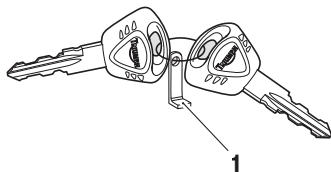

1. Key number tag

In addition to operating the steering lock/ignition switch, the ignition key is required to operate the seat lock and fuel tank cap.

When the motorcycle is delivered from the factory, two keys are supplied together with a small tag bearing the key number. Make a note of the key number and store the spare key and key number tag in a safe place away from the motorcycle.

A transponder is fitted within the key to turn off the engine immobiliser. To ensure the immobiliser functions correctly, always have only one of the ignition keys near the ignition switch. Having two ignition keys near the switch may interrupt the signal between the transponder and the engine immobiliser. In this situation the engine immobiliser will remain active until one of the ignition keys is removed.

Always get replacement keys from your authorised Triumph dealer. Replacement keys must be 'paired' with the motorcycle's immobiliser by your authorised Triumph dealer.

Caution

Do not store the spare key with the motorcycle as this will reduce all aspects of security.

Engine Immobiliser

The ignition barrel housing acts as the antenna for the engine immobiliser. When the ignition switch is turned to the OFF position and the ignition key is removed, the engine immobiliser is active (see page 28). The engine immobiliser is deactivated when the ignition key is in the ignition switch and it is turned to the ON position.

Ignition Switch/Steering Lock

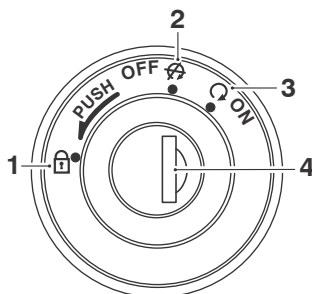

1. LOCK position
2. OFF position
3. ON position
4. Ignition switch/steering lock

Ignition Switch Positions

This is a three position, key operated switch. The key can be removed from the switch only when it is in the OFF or LOCK position.

To lock the motorcycle:

- Turn the handlebar fully to the left.
- Turn the key to the OFF position.
- Push and fully release the key.
- Rotate it to the LOCK position.

Warning

For reasons of security and safety, always move the ignition switch to the OFF position and remove the key when leaving the motorcycle unattended.

Any unauthorised use of the motorcycle may cause injury to the rider, other road users and pedestrians and may also cause damage to the motorcycle.

Warning

With the key in the LOCK position the steering will become locked.

Never turn the key to the LOCK position while the motorcycle is moving as this will cause the steering to lock.

Locked steering will cause loss of motorcycle control and an accident.

Right Handlebar Switches

All Models except Tiger 800 XR

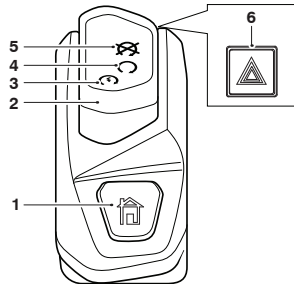

1. **HOME button**
2. **Engine start/stop switch**
3. **START position**
4. **RUN position**
5. **STOP position**
6. **Hazard warning lights switch**

The following sections describe the handlebar buttons and switches functions.

HOME Button

The HOME button is used to access the main menu on the instrument display.

Press and release the HOME button to select between the main menu and instrument display.

Engine Stop Switch

In addition to the ignition switch being turned to the ON position, the engine stop switch must be in the RUN position for the motorcycle to operate.

General Information

The engine stop switch is for emergency use. If an emergency arises which requires the engine to be stopped, move the engine stop switch to the STOP position.

Note:

- Although the engine stop switch stops the engine, it does not turn off all the electrical circuits and may cause difficulty in restarting the engine due to a discharged battery. Ordinarily, only the ignition switch should be used to stop the engine.

⚠ Caution

Do not leave the ignition switch in the ON position unless the engine is running as this may cause damage to electrical components and will discharge the battery.

Starter Button

The starter button operates the electric starter. For the starter to operate, the clutch lever must be pulled to the handlebar.

Note:

- Even if the clutch lever is pulled to the handlebar, the starter will not operate if the side stand is down and a gear is engaged.

Hazard Warning Lights Button

To turn the hazard warning lights on or off, press and release the hazard warning light button.

The ignition must be switched on for the hazard warnings lights to be activated, but the hazard lights will remain active if the ignition is switched off until the hazard warning light button is pressed again.

Right Handlebar Switches

Tiger 800 XR Only

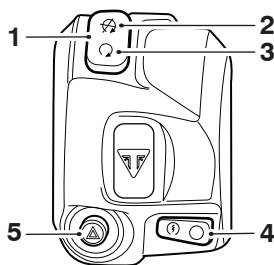

1. Engine stop switch
2. STOP position
3. RUN position
4. Starter button
5. Hazard warning light switch

The following sections describe the handlebar buttons and switches functions.

Engine Stop Switch

In addition to the ignition switch being turned to the ON position, the engine stop switch must be in the RUN position for the motorcycle to operate.

The engine stop switch is for emergency use. If an emergency arises which requires the engine to be stopped, move the engine stop switch to the STOP position.

Note:

- Although the engine stop switch stops the engine, it does not turn off all the electrical circuits and may cause difficulty in restarting the engine due to a discharged battery. Ordinarily, only the ignition switch should be used to stop the engine.



Caution

Do not leave the ignition switch in the ON position unless the engine is running as this may cause damage to electrical components and will discharge the battery.

Starter Button

The starter button operates the electric starter. For the starter to operate, the clutch lever must be pulled to the handlebar.

Note:

- Even if the clutch lever is pulled to the handlebar, the starter will not operate if the side stand is down and a gear is engaged.

Hazard Warning Lights

To turn the hazard warning lights on or off, press the hazard warning light button.

The ignition must be switched ON for the hazard warning lights to function, but the hazard warning lights remain on if the ignition is switched OFF until the hazard warning light button is pressed again.

Left Handlebar Switches

All Models except Tiger 800 XR

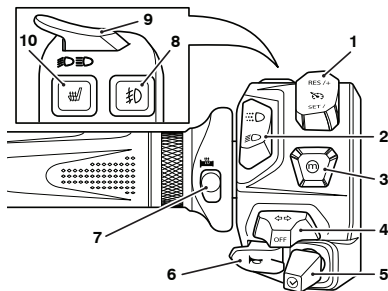

1. Cruise control adjust switch
2. Daytime Running Lights (DRL) switch (if fitted)
3. MODE button
4. Direction indicator switch
5. Joystick button
6. Horn button
7. Heated grips switch
8. Front fog lights switch (if fitted)
9. High beam button
10. Rider and passenger heated seats switch (if fitted)

The following sections describe the handlebar buttons and switches functions.

Cruise Control Adjust Button

The cruise control adjust button is a two way switch with the top marked RES/+ and the bottom marked SET/-.

For more information on cruise control operation, see page 90.

General Information

Daytime Running Lights (DRL) Switch (if fitted)



When the ignition is switched ON and the daytime running lights switch is set to DRL mode, the daytime running lights warning light will illuminate.

The daytime running lights and low beam headlights are operated manually using the DRL switch. Press the top of the switch for DRL mode, and the bottom of the switch for low beam headlight mode.

Warning

Do not ride for longer than necessary in poor ambient light conditions with the Daytime Running Lights (DRL) in use.

Riding with the daytime running lights when dark, in tunnels or where poor ambient light is apparent may reduce the riders vision or dazzle other road users.

Dazzling other road users or reduced vision in low ambient light levels may result in loss of motorcycle control and an accident.

Note:

- **During daylight hours the daytime running lights improve the motorcycles visibility to other road users.**
- **Low beam headlights must be used in any other conditions unless the road conditions allow for high beam headlights to be used.**

MODE Button

When the MODE button is pressed and released it will activate the Riding Mode Selection Menu in the display screen. Further presses of the MODE button will scroll through the available riding modes, see Riding Mode Selection on page 35.

Press and hold the MODE button when a riding mode is selected provides direct access to the riding mode's configuration menu.

For more information on riding mode selection and configuration, see page 44.

Direction Indicator Switch

When the indicator switch is pushed to the left or right and released, the corresponding direction indicators will flash on and off. To turn off the indicators, push and release the switch in the central position.

Models Equipped with Automatic Self-Cancelling Indicators

A short press and release of the indicator switch to the left or right will cause the corresponding direction indicators to flash on and off three times, then go off.

A longer press and release of the indicator switch to the left or right will cause the corresponding direction indicators to flash on and off.

The indicators are automatically turned off after eight seconds and after riding a further 65 metres.

To disable the indicator self-cancel system refer to the Bike Setup section on page 45.

The indicators can be cancelled manually. To manually turn off the indicators, press and release the indicator switch in the central position.

Joystick Button

The Joystick is used to operate the following functions of the instruments:

- Up - scroll the menu from the bottom to the top
- Down - scroll the menu from the top to the bottom
- Left - scroll the menu to the left
- Right - scroll the menu to the right
- Centre - press to confirm selection.

Horn Button

When the horn button is pushed, with the ignition switch turned to the ON position, the horn will sound.

Heated Grips Switch

The heated grips will only heat when the engine is running.

When the heated grips are switched on, the heated grips symbol will appear in the display and the selected heat level will be shown.

There are three levels of heat: low, medium and high. This is indicated by the different colours of the symbols shown in the display.

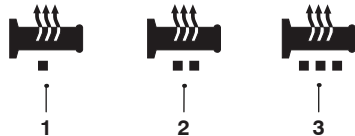

1. Low heat symbol (yellow)
2. Medium heat symbol (orange)
3. High heat symbol (red)

For maximum benefit in cold conditions, from the OFF position press the switch once for the high heat setting initially and then reduce the heat level by pressing the switch again for a low heat setting when the grips have warmed up.

To turn off the heated grips, press and release the switch until the heated grips symbol is no longer shown in the display.

Low Power Voltage Cut Off

If a low voltage is detected, the heated grips switch will power off. The heated grips will not function again until the voltage rises to a safe level.

The switch will not power back on automatically even if the voltage rises to the safe level. The user must manually press the switch again to activate the heated grips.

Fog Lights Switch (if fitted)

To turn the fog lights on or off, with the headlights on, press and release the fog lights switch. When the fog lights are turned on, the fog lights indicator will illuminate in the display.

General Information

Note:

- The fog lights switch will only operate when the headlights are on.
- The fog lights switch will reset to off when the ignition is turned off then on again.

High Beam Button

The high beam button has a different function depending on whether Daytime Running Lights (DRL) are fitted or not. When the high beam is turned on, the high beam indicator light will illuminate in the display.

Models with Daytime Running Lights (DRL)

If the DRL switch is in the Daytime Running Lights (DRL) position, then press and hold the high beam button to turn the high beam on. It will remain on as long as the button is held in and will turn off as soon as the button is released.

If the DRL switch is in the dip beam position, press the high beam button to switch the high beam on. Each press of the button will swap between dip and high beam.

Note:

- A lighting on/off switch is not fitted to this model. The rear light and licence plate light all function automatically when the ignition is turned to the ON position.
- The headlight will function when the ignition is turned on and the engine is running.

Models without Daytime Running Lights (DRL)

Press the high beam button to switch the high beam on. Each press of the button will swap between dip and high beam.

Note:

- A lighting on/off switch is not fitted to this model. The position light, rear light and licence plate light all function automatically when the ignition is turned to the ON position.
- The headlight will function when the ignition is turned on and the engine is running.

Rider and Passenger Heated Seat Switch (if fitted)

The rider and passenger heated seats will only heat when the engine is running. When the heated seats are switched on, then the heated seats symbols will appear in the display. The selected heat level will also be indicated by the colour of the symbol.

For more information, see page 105.

Left Handlebar Switches

Tiger 800 XR

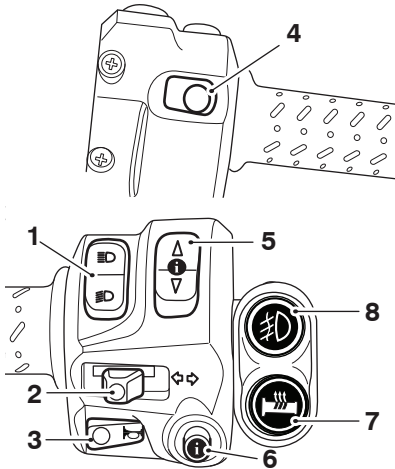

1. Headlight dip switch
2. Direction indicator switch
3. Horn button
4. Pass button
5. Instrument SCROLL button
6. Instrument SET button
7. Heated grips switch (if fitted)
8. Fog lights switch (if fitted)

The following sections describe the handlebar buttons and switches functions.

Headlight Dip Switch

High or low beam can be selected with the headlight dip switch.

To select high beam, push the switch forward.

To select low beam, push the switch rearwards.

When the high beam is turned on, the high beam indicator light will illuminate.

Note:

- A lighting ON/OFF switch is not fitted to this model. The position light, rear light and licence plate light all function automatically when the ignition is turned to the ON position.
- The headlight will only function when the ignition switch is turned to the ON position and the engine is running. An alternate way to turn on the headlight, without the engine running, is to pull in the clutch lever then turn the ignition to the ON position. The headlight will be on and remain on when the clutch lever is released. The headlight will go off while pressing the starter button until the engine starts.

Direction Indicator Switch

The direction indicators can also be cancelled manually. To manually cancel the indicators, press and release the direction indicator switch in the central position.

Horn Button

When the horn button is pushed, with the ignition switch turned to the ON position, the horn will sound.

General Information

Pass Button

 **Caution**

The headlamp pass switch is intended for intermittent use only.

Use of the pass switch for extended periods of time may cause the fuse to fail resulting in loss of headlamp operation.

Note:

- **The pass button will only operate when the engine is running.**

When the pass button is pressed, the headlight main beam will be switched on. It will remain on as long as the button is held in and will turn off as soon as the button is released.

Instrument SCROLL Button

When the SCROLL button is pressed and released it will scroll through the menu shown in the instrument's display screen.

Instrument SET Button

When the SET button is pressed it will select the menu shown in the instrument's display screen.

Heated Grips Switch (if fitted)

The heated grips switch (if fitted) is located on the left hand handlebar, next to the left handlebar switch housing.

The heated grips will only heat when the engine is running.

The system is designed to offer a variable level of heat at the grips from warm to hot.

The outer ring of the switch will illuminate as follows for each heat setting:

- OFF - not illuminated
- HOT - red
- WARM - amber.

For maximum benefit in cold conditions, from the OFF position press the switch once for hot (red) initially and then reduce the heat level by pressing the switch again for warm (amber) when the grips have warmed up.

To turn off the heated grips, press and release the switch until it is not illuminated.

Low Power Voltage Cut Off

When the detected voltage is lower than 11.8 volts continually for more than five minutes the LED in the heated grip switch will flash five times. After the fifth flash the main switch will power off the heated grips and the LED indicator.

The main switch will not power back on automatically even if the voltage rises to the safe level.

The user must manually press the switch again to activate the heated grips.

If the detected voltage is still lower than 11.8 volts, the LED for the switch will flash five times again and cut off the power automatically.

There is a specific fuse that protects the heated grip circuit. See page **178** for the fuse amperage.

Fog Lights Switch (if fitted)

To turn the fog lights on or off, with the ignition switch turned to the ON position, press and release the fog light switch.

When the fog lights are switched on, the outer ring of the switch will illuminate green.

The switch will automatically reset to off whenever the ignition switch is turned off then on again.

Throttle Control

This Triumph model has an electronic throttle twist grip to open and close the throttles via the engine control unit. There are no direct-acting cables in the system.

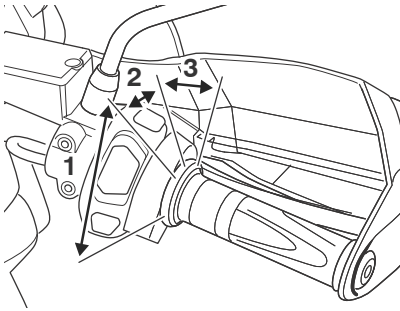

1. Throttle open position
2. Throttle closed position
3. Cruise control cancel position

The throttle grip has a resistive feel to it as it is rolled rearwards to open the throttles. When the grip is released it will return to the throttle closed position by its internal return spring and the throttles will close.

From the closed position, the throttle twist grip can be rolled forward 3 - 4 mm to deactivate the cruise control (if fitted), see page 90.

There are no user adjustments for the throttle control.

If there is a malfunction with the throttle control the Malfunction Indicator Light (MIL) becomes illuminated and one of the following engine conditions may occur:

- MIL illuminated, restricted engine RPM and throttle movement
- MIL illuminated, limp-home mode with the engine at a fast idle condition only
- MIL illuminated, engine will not start.

For all of the above conditions contact an authorised Triumph dealer as soon as possible to have the fault checked and rectified.

Brake Use

At low throttle opening (approximately 20°), the brakes and throttle can be used together.

At high throttle opening (greater than 20°), if the brakes are applied for greater than two seconds the throttles will close and the engine speed will reduce. To return to normal throttle operation, release the throttle control, release the brakes and then reopen the throttle.

General Information

Warning

Reduce speed and do not continue to ride for longer than is necessary with the MIL illuminated. The fault may adversely affect engine performance, exhaust emissions and fuel consumption.

Reduced engine performance could cause a dangerous riding condition, leading to loss of control and an accident.

Contact an authorised Triumph dealer as soon as possible to have the fault checked and rectified.

Brake and Clutch Lever Adjusters

Warning

Do not attempt to adjust the lever with the motorcycle in motion as this may lead to loss of motorcycle control and an accident.

After adjusting the lever, operate the motorcycle in an area free from traffic to gain familiarity with the new lever setting. Do not loan your motorcycle to anyone as they may change the lever setting from the one you are familiar with causing loss of motorcycle control and an accident.

An adjuster is fitted to both the front brake and clutch levers. The adjusters allow the distance from the handlebar to the lever to be changed to one of five positions for the front brake lever or four positions for the clutch lever, to suit the span of the operator's hands.

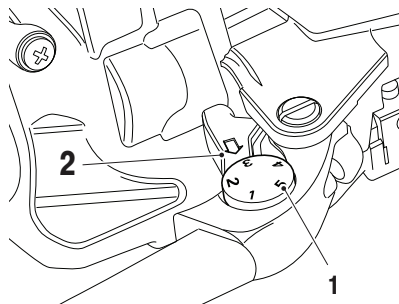

1. Adjuster wheel, brake lever shown
2. Arrow mark

To adjust the lever, push the lever forward and turn the adjuster wheel to align one of the numbered positions with the arrow mark on the lever holder.

The distance from the handlebar grip to the released lever is shortest when set to number five, and longest when set to number one.

ABS Options

Warning

If the ABS is disabled, the brake system will function as a non-ABS braking system.

In this situation braking too hard will cause the wheels to lock, and may result in loss of motorcycle control and an accident.

All Models except Tiger 800 XR

For information on enabling and disabling the ABS, see Bike Set Up - ABS.

Tiger 800 XR Model Only

To disable the ABS:

- Press the SCROLL button and select ABS Off.
- Press the SET button to confirm.

To enable the ABS:

- Turn the ignition off and on again.

Cruise Control

All Models except Tiger 800 XR

Warning

Cruise control must only be used where you can drive safely at a steady speed.

Cruise control should not be used when riding in heavy traffic, on roads with sharp/blind bends or when they are slippery.

Using cruise control in heavy traffic, on roads with sharp/blind bends or when they are slippery, may result in loss of motorcycle control and an accident.

Warning

This Triumph motorcycle should be operated within the legal speed limits for the particular road travelled. Operating a motorcycle at high speeds can be potentially dangerous since the time available to react to given traffic situations is greatly reduced as speed increases. Always reduce speed in consideration of weather and traffic conditions.

General Information

Warning

Only operate this Triumph motorcycle at high speed in closed-course, on-road competition or on closed-course racetracks. High speed operation should only then be attempted by riders who have been instructed in the techniques necessary for high speed riding and are familiar with the motorcycle's behaviour in all conditions.

High speed operation in any other circumstances is dangerous and will lead to loss of motorcycle control and an accident.

Note:

- **Cruise control may not function if there is a malfunction with the ABS system and the ABS warning light is illuminated.**
- **Cruise control will continue to function if a riding mode is selected with ABS set to Off-Road or Off.**
- **Cruise control will continue to function if ABS has been disabled.**

The cruise control buttons are located on the left hand switch housing and can be operated with minimum movement by the rider.

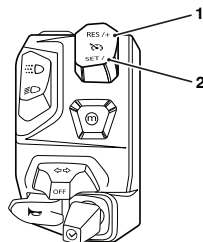

1. **Cruise control RES/+ button**
2. **Cruise control SET/- button**

Cruise control can be switched on or off at any time but it can not be activated until all the conditions described on page 90 have been met.

Activating Cruise Control

To turn on the cruise control system, press the SET/- button. The cruise control symbol will be shown in the display screen. The cruise control set speed will be shown as '--' indicating that a speed has not yet been set.

To activate cruise control, the following conditions have to be met:

- The motorcycle must be travelling at a speed between 19 to 100 mph (30 to 160 km/h).
- The motorcycle must be in 3rd gear or higher.
- Once these conditions have been met, press the SET/- button to activate cruise control. The cruise control symbol will be shown in a green light in the TFT display to indicate that cruise control is now active.

The word SET will be shown next to the cruise control symbol. The cruise control set speed will be shown and the cruise control light will illuminate in the tachometer indicating that cruise control is active.

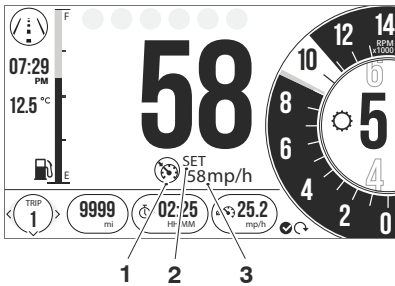

1. Cruise control symbol
2. Cruise control set indicator
3. Cruise control set speed

The cruise control system will maintain the set speed until:

- The set speed is adjusted as described on page 91.
- Cruise control is deactivated as described on page 91.

Adjusting the Set Speed While in Cruise Control

To adjust the set speed while in cruise control, press and release the:

- RES/+ button to increase the speed
- SET/- button to decrease the speed.

Each press of the buttons will adjust the speed by 1 mph or 1 km/h. If the buttons are held, the speed continuously increases or decreases in single digit increments.

Stop pressing the adjust button when the desired speed is shown in the display.

Note:

- The cruise control set speed display will flash until the new set speed has been achieved.
- If riding up a steep incline and cruise control is unable to maintain the set speed, the cruise control set speed display will flash until the motorcycle has regained the set speed.

An alternative way to increase the speed in cruise control is to accelerate to the desired speed using the throttle grip and then press the SET/- button.

Deactivating Cruise Control

The cruise control can be deactivated by one of the following methods:

- Roll the throttle twist grip fully forward.
- Pull the clutch lever.
- Operate the front or rear brake.
- Increase speed by using the throttle for more than 60 seconds.

General Information

Upon deactivation, the cruise control light will go out in the tachometer but the SET indicator and set speed will still be shown in the display screen, indicating that the cruise control set speed has been stored.

The cruise control set speed can be resumed as described on page 92, provided the cruise control has not been deactivated by turning the ignition switch to the OFF position.

A stored set speed is indicated by the word SET next to the cruise control symbol in the display screen.

The stored set speed will remain in the cruise control memory until the ignition switch has been turned to the OFF position.

Note:

- **The cruise control set speed display will flash until the resumed set speed has been achieved.**

Resuming the Cruise Control Set Speed

 **Warning**

When resuming cruise control, always make sure that the traffic conditions are suitable for the set speed.

Using cruise control in heavy traffic, on roads with sharp/blind bends or when they are slippery, may result in loss of motorcycle control and an accident.

Cruise control will be deactivated if one of the following actions has been taken:

- Roll the throttle twist grip fully forward.
- Pull the clutch lever.
- Operate the front or rear brake.
- Increase speed by using the throttle grip for more than 60 seconds.

The cruise control set speed can be resumed by pressing and releasing the RES/+ button provided a set speed has been stored.

The motorcycle must be travelling at a speed between 19 to 100 mph (30 to 160 km/h) and be in 3rd gear or higher.

Traction Control (TC)

Warning

Traction control is not a substitute for riding appropriately for the prevailing road and weather conditions.

The traction control cannot prevent loss of traction due to:

- Excessive speed when entering turns
- Accelerating at a sharp lean angle
- Braking
- Traction control cannot prevent the front wheel from slipping.

Failure to observe any of the above may result in loss of motorcycle control and an accident.

Traction control helps to maintain traction when accelerating on wet/slippery road surfaces. If sensors detect that the rear wheel is losing traction (slipping), the traction control system will engage and alter the engine power until traction to the rear wheel has been restored. The traction control warning light will flash while it is engaged and the rider may notice a change to the sound of the engine.

Note:

- **Traction control will not function if there is a malfunction with the ABS system. The warning lights for the ABS, traction control and the MIL will be illuminated.**

Traction Control Settings

Warning

Do not attempt to adjust the traction control settings while the motorcycle is in motion as this may lead to loss of motorcycle control and an accident.

In the LCD instrument displays, traction control is shown as 'TTC' which refers to Triumph Traction Control (TTC). In the TFT instrument displays it is shown as 'TC' which refers to Traction Control (TC). Both TC and TTC are the same traction control system.

The Triumph Traction Control can be set to one of the following conditions:

- **On/Road** – Optimal TTC setting for road use, allows minimal rear wheel slip
- **Off Road** – TTC is set up for off-road use, allowing increased rear wheel slip when compared to the Road setting. The TTC indicator light will flash slowly.
- **Off** – TTC is turned off. The TTC disabled warning light will be illuminated.

Warning

If the traction control is disabled, the motorcycle will handle as normal but without traction control.

In this situation accelerating too hard on wet/slippery road surfaces may cause the rear wheel to slip, and may result in loss of motorcycle control and an accident.

General Information

To access the TTC settings in the LCD instrument display, see page **68**.

To access the TC settings in the TFT instrument display, see page **46**.

Tyre Pressure Monitoring System (TPMS) (if fitted)



Warning

The daily check of tyre pressures must not be excluded because of the fitment of the TPMS. Check the tyre pressure when the tyres are cold and using an accurate tyre pressure gauge (see page **167**).

Use of the TPMS system to set inflation pressures may lead to incorrect tyre pressures leading to loss of motorcycle control and an accident.

Function

Tyre pressure sensors are fitted to the front and rear wheels. These sensors measure the air pressure inside the tyre and transmit pressure data to the instruments. These sensors will not transmit the data until the motorcycle is travelling at a speed greater than 12 mph (20 km/h). Two dashes will be visible in the display area until the tyre pressure signal is received.

An adhesive label will be fitted to the wheel rim to indicate the position of the tyre pressure sensor, which is near the valve.

For motorcycles without the tyre pressure monitoring system fitted: The Tyre Pressure Monitoring System (TPMS) is an accessory fitted item and must be fitted by your authorised Triumph dealer. The TPMS display on the instruments will only be activated when the system has been fitted.

Tyre Pressure Sensor Serial Number

The serial number for the tyre pressure sensor is printed on a label attached to the sensor. This number may be required by your authorised Triumph dealer for service or diagnostics.

When the tyre pressure monitoring system is being fitted to the motorcycle, make sure that your authorised Triumph dealer records the serial numbers of the front and rear tyre pressure sensors in the spaces provided below.

Front Tyre Pressure Sensor

Rear Tyre Pressure Sensor

TPMS Display

The Tyre Pressure Monitoring System (TPMS) display is accessed from the Information menu (LCD instrument display) or Information tray (TFT instrument display).

TFT Instrument Display

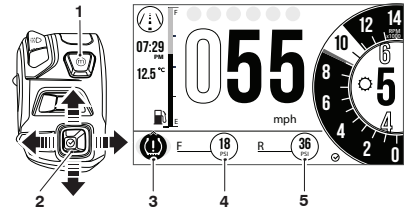

1. Mode button
2. Joystick control
3. TPMS light
4. Front tyre indicator
5. Rear tyre indicator

LCD Instrument Display

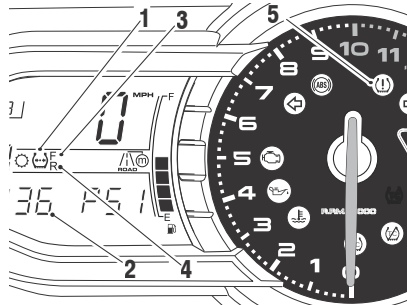

1. TPMS symbol
2. Tyre pressure display
3. Front tyre, identified
4. Rear tyre, identified
5. TPMS warning light

General Information

When the front or rear tyre pressure display has been selected, -- PSI or bAR will be shown in the LCD instrument display screen until the motorcycle is travelling at a speed greater than 12 mph (20 km/h) and the tyre pressure signal is received.

Once the tyre pressure signal has been received, the pressure of the selected tyre will be displayed.

TPMS Symbol

With the ignition switch turned to the ON position, if the TPMS symbol flashes for 10 seconds and then remains on, there is a fault with the TPMS system. Contact your authorised Triumph dealer to have the fault rectified.

TPMS Sensor Batteries

When the battery voltage in a pressure sensor is low, lo bAtt will be displayed for eight seconds and the TPMS symbol will indicate which wheel sensor has the low battery voltage. If the batteries are completely flat, only dashes will be shown in the display screen, the red TPMS warning light will be on and the TPMS symbol will flash continuously. Contact your authorised Triumph dealer to have the sensor replaced and the new serial number recorded in the spaces provided in page **95**.

TPMS Tyre Pressures



The tyre pressure monitoring system is not to be used as a tyre pressure gauge when adjusting the tyre pressures. For correct tyre pressures, always check the tyre pressures when the tyres are cold and using an accurate tyre pressure gauge.

Use of the TPMS system to set inflation pressures may lead to incorrect tyre pressures leading to loss of motorcycle control and an accident.

The tyre pressures shown on your instrument panel indicate the actual tyre pressure at the time of selecting the display. This may differ from the inflation pressure set when the tyres are cold because tyres become warmer during riding, causing the air in the tyre to expand and the inflation pressure to increase. The cold inflation pressures specified by Triumph take account of this.

Replacement Tyres

When replacing tyres, always have an authorised Triumph dealer fit your tyres and make sure that they are aware that tyre pressure sensors are fitted to the wheels.

Fuel



cbny

Fuel Grade

Your Triumph engine is designed to use unleaded fuel and will give optimum performance if the correct grade of fuel is used. Always use unleaded fuel with a minimum octane rating of 91 RON.

In certain circumstances engine calibration may be required. Always refer to your authorised Triumph dealer.

Caution

The motorcycle can be permanently damaged if it is allowed to operate with the incorrect grade of fuel or incorrect engine calibration.

Always make sure the fuel used is of the correct grade and quality.

Damage caused by using the incorrect fuel or engine calibration is not considered a manufacturing defect and will not be covered under warranty.

Caution

The exhaust system for this motorcycle is fitted with a catalytic converter to help reduce exhaust emission levels.

Use of leaded fuel will damage the catalytic converter. In addition, the catalytic converter can be permanently damaged if the motorcycle is allowed to run out of fuel or if the fuel level is allowed to get very low.

Always make sure you have adequate fuel for your journey.

Note:

- **The use of leaded fuel is illegal in some countries, states or territories.**

General Information

Refuelling

Warning

To help reduce hazards associated with refuelling, always observe the following fuel safety instructions:

- Petrol (fuel) is highly flammable and can be explosive under certain conditions. When refuelling, turn the ignition switch to the OFF position.
- Do not smoke.
- Do not use a mobile telephone.
- Make sure the refuelling area is well ventilated and free from any source of flame or sparks. This includes any appliance with a pilot light.
- Never fill the tank until the fuel level rises into the filler neck. Heat from sunlight or other sources may cause the fuel to expand and overflow creating a fire hazard.
- After refuelling always check that the fuel filler cap is correctly closed.
- Because petrol (fuel) is highly flammable, any fuel leak or spillage, or any failure to observe the safety advice given above will lead to a fire hazard, which could cause damage to property, injury to persons or death.

Fuel Tank Cap

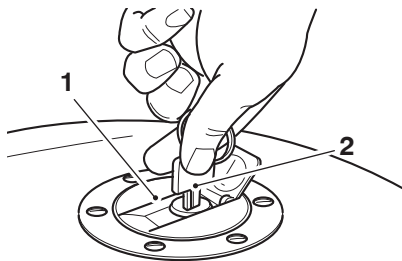

1. Fuel tank cap
2. Key

To open the fuel tank cap, lift up the flap covering the lock itself. Insert the key into the lock and turn the key clockwise.

To close and lock the cap, push the cap down into place with the key inserted, until the lock clicks into place. Withdraw the key and close the key cover.

Caution

Closing the cap without the key inserted will damage the cap, tank and lock mechanism.

Filling the Fuel Tank

Warning

Overfilling the tank can lead to fuel spillage.

If fuel is spilled, thoroughly clean up the spillage immediately and dispose of the materials used safely.

Take care not to spill any fuel on the engine, exhaust pipes, tyres or any other part of the motorcycle.

Because fuel is highly flammable, any fuel leak or spillage, or any failure to observe the safety advice given above may lead to a fire hazard, which could cause damage to property and injury or death to persons.

Fuel spilled near to, or onto the tyres will reduce the tyres' ability to grip the road. This will result in a dangerous riding condition potentially causing loss of motorcycle control and an accident.

Caution

Avoid filling the tank in rainy or dusty conditions where airborne material can contaminate the fuel.

Contaminated fuel may cause damage to fuel system components.

Fill the fuel tank slowly to help prevent spillage. Do not fill the tank to a level above the bottom of the filler neck. This will make sure there is enough air space to allow for fuel expansion if the fuel inside the tank expands through absorption of heat from the engine or from direct sunlight.

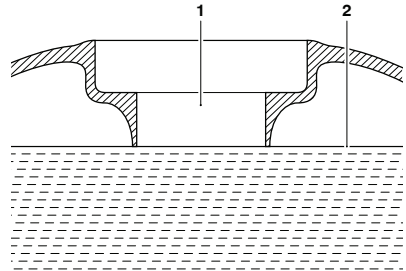

1. **Fuel filler neck**
2. **Maximum fuel level**

After refuelling always check that the fuel filler cap is correctly closed.

General Information

Handlebar Adjustment

Warning

It is recommended to have handlebar adjustments carried out by a trained technician of an authorised Triumph dealer.

Handlebar adjustments carried out by a technician who is not of an authorised Triumph dealer may affect the handling, stability or other aspects of the motorcycle's operation which may result in loss of motorcycle control and an accident.

Warning

Before starting work, make sure that the motorcycle is stabilised and adequately supported.

This will help prevent personal injury and/or damage to the motorcycle.

Note:

- This procedure assumes the handlebars are in the standard position, as delivered from the factory. If the handlebars have already been adjusted as described below, the fixing positions will be reversed.

The handlebars are adjustable for reach by approximately 20 mm.

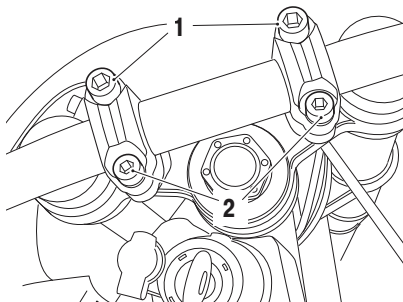

1. 10 mm fixings
2. 8 mm fixings

To adjust the handlebars:

- Loosen and remove the handlebar rear (8 mm threaded) clamp fixings, and then the front (10 mm threaded) clamp and riser fixings.
- Lift the handlebars out of the handlebar risers and support with the aid of an assistant.
- Rotate both risers through 180° and align the fixing holes.
- Reposition the handlebars to the risers.
- Refit the upper clamps, and secure with the two 10 mm threaded fixings in the rear fixing positions. Do not fully tighten the fixings at this stage.
- Rotate the handlebar so that the alignment marking on the handlebar aligns with the split line on the upper clamps/risers.

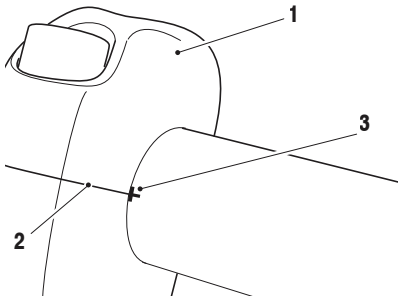

1. Upper clamp
2. Clamp split line
3. Alignment marking (Tiger 800 XRX shown)

- Tighten the 10 mm fixings to **35 Nm**.
- Refit the 8 mm fixings to the front positions and tighten to **26 Nm**.

Satellite Navigation Mounting Bracket (if fitted)

The satellite navigation bracket features a mounting plate that is compatible with Garmin Nuvi® Satellite Navigation Systems 660 and 220.

Other satellite navigation systems may be compatible.

When installing a satellite navigation system, refer to the manufacturer's instructions.

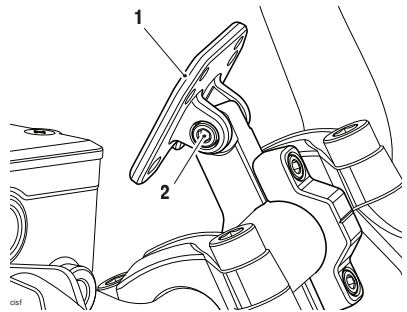

1. Mounting plate
2. Pivot bolt

To adjust the mounting plate:

- Loosen the pivot bolt.
- Set the mounting plate to the desired position.
- Retighten the pivot bolt to **5 Nm**.

The satellite navigation mounting bracket is available as an accessory kit from your authorised Triumph dealer.

General Information

Stands

Side Stand

Warning

The motorcycle is fitted with an interlock system to prevent it from being ridden with the side stand in the down position.

Never attempt to ride with the side stand down or interfere with the interlock mechanism as this will cause a dangerous riding condition leading to loss of motorcycle control and an accident.

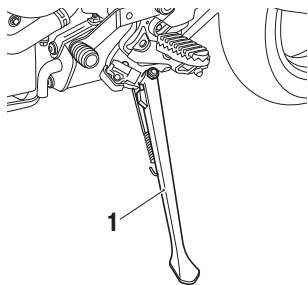

1. Side stand

The motorcycle is equipped with a side stand on which the motorcycle can be parked.

Whenever the side stand is used, before riding, always make sure that the side stand is fully up after first sitting on the motorcycle.

When parking the motorcycle using the side stand, always turn the handlebars fully to the left and leave the motorcycle in first gear.

For instructions on safe parking, refer to the How to Ride the Motorcycle section.

Centre Stand (if fitted)

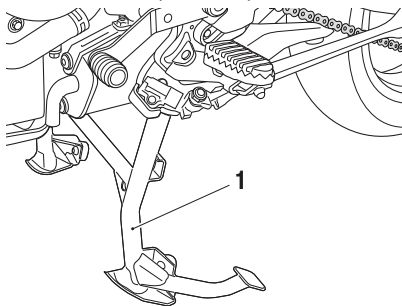

1. Centre stand

To set the motorcycle on the centre stand:

- Hold the motorcycle upright.
- Step down firmly on the foot finder part of the stand.
- Lift the motorcycle up and to the rear using the rear grab rail as a handhold.

For instructions on safe parking, refer to the How to Ride the Motorcycle section.

Caution

Do not use body panels or the seat as a hand-hold when placing the motorcycle on the centre stand as this will cause damage.

Seats

Seat Care

To prevent damage to the seat or seat cover, care must be taken not to drop or lean the seat against any surface which may damage the seat or seat cover.

See page 187 for seat cleaning information.

Caution

To prevent damage to the seat or seat cover, care must be taken not to drop the seat. Do not lean the seat against the motorcycle or any surface which may damage the seat or seat cover. Instead, place the seat, with the seat cover facing upwards, on a clean, flat surface which is covered with a soft cloth.

Do not place any item on the seat which may cause damage or staining to the seat cover.

Passenger Seat

Warning

The rider's seat is only correctly retained and supported once the passenger seat is correctly fitted.

Never ride the motorcycle with the passenger seat detached or removed, as the front seat will not be secure and may move.

A loose or detached seat could cause loss of motorcycle control and an accident.

Warning

To prevent detachment of the seat during riding, after fitting always grasp the seat and pull firmly upwards.

If the seat is not correctly secured, it will detach from the lock.

A loose or detached seat could cause loss of motorcycle control and an accident.

The seat lock is located on the rear mudguard, below the rear light unit.

Passenger Seat Removal

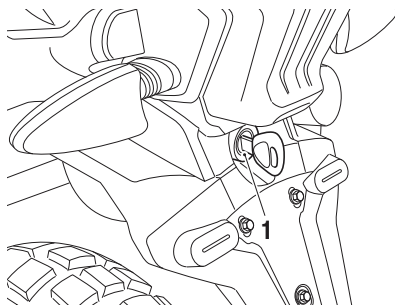

1. Seat lock

To remove the passenger seat:

- Insert the ignition key into the seat lock.
- Turn the ignition key anticlockwise while pressing down on the rear of the seat. This will release the seat from its lock and allow it to be slid rearwards.
- If equipped with heated seats, disconnect the heated seat's electrical connector for complete removal from the motorcycle.

General Information

Passenger Seat Refit

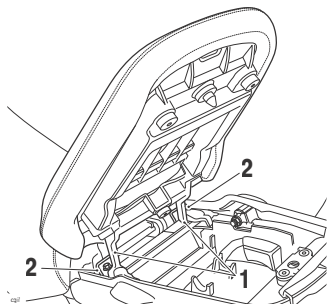

1. Passenger seat brackets
2. Subframe loops

To refit the seat:

- Reconnect the heated seat's electrical connector (if equipped).
- Engage the seat's two brackets under the loops on the subframe.
- Press down at the rear to engage in the seat lock.

Rider's Seat



The rider's seat is only correctly retained and supported once the passenger seat is correctly fitted.

Never ride the motorcycle with the pillion seat detached or removed, as the front seat will not be secure and may move.

A loose or detached seat could cause loss of motorcycle control and an accident.

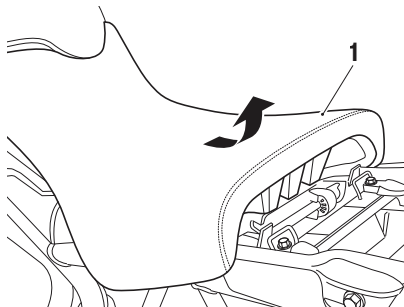

1. Rider's seat

To remove the rider's seat:

- Remove the passenger seat (see page 103).
- Grasp the rider's seat on either side, and slide it rearwards and upwards.
- If equipped with heated seats, disconnect the heated seat's electrical connector for complete removal from the motorcycle.

To refit the seat:

- Reconnect the heated seat's electrical connector (if equipped).
- Engage the seat's front rail into the bracket at the rear of the fuel tank and lower the rear rail in to the rear brackets.
- Push down firmly on the rear of the seat.
- Refit the passenger seat (see page 103).

Rider's Seat Height Adjustment

The rider's seat is adjustable for height by approximately 25 mm.

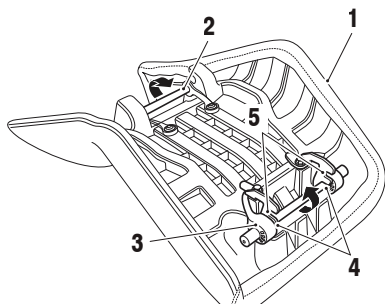

1. Rider's seat
2. Front seat height adjuster
3. Passenger seat height adjuster
4. Low seat height position (rear shown)
5. High seat height position (rear shown)

To adjust the rider's seat:

- Remove the rider's seat (see page 104).
- Reposition both seat height adjusters to the higher or lower position as required.
- Make sure that both adjuster rails are fully engaged in their brackets on the seat.
- Refit the rider's seat (see page 104).

Warning

Always adjust both seat height adjusters. Adjusting only one height adjuster may prevent correct fitment of the seat.

Riding the motorcycle with an incorrectly fitted seat may cause loss of motorcycle control and an accident.

Warning

After adjusting the seat, operate the motorcycle in an area free from traffic to gain familiarity with the new seat position.

Riding the motorcycle with the seat in an unfamiliar position may cause loss of motorcycle control and an accident.

Heated Seats (if fitted)

The heated seats switch (if fitted) is located on the left hand side hand grip. The heated seat switch operates both the rider and passenger heated seats.

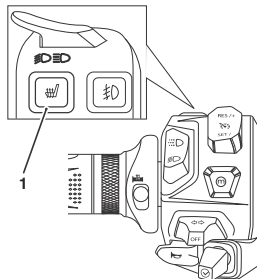

1. Heated seat switch

General Information

The heated seats will only heat when the engine is running. When the heated seats are switched on, the heated seats symbol will appear in the display. The selected heat level for each seat will also be indicated by the colour of the symbol.

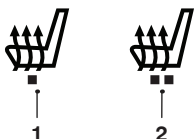

1. Low heat symbol (amber)
2. High heat symbol (red)

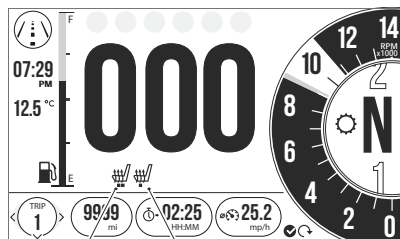

1. Rider's heated seat (high heat selected)
2. Passenger's heated seat (switched on)

Rider's Heated Seat

- The rider's heated seat is operated by a quick press on the heated seat switch. Each quick press of the heated seats switch will change the rider heated seat settings in the following order: OFF - HIGH - LOW - OFF.
- For maximum benefit in cold conditions, from the OFF position press the heated seat switch for the high heat setting initially, and then reduce the heat level by pressing the heated seat switch again for the low heat setting when the seat has warmed up.

Passenger's Heated Seat

- The passenger's heated seat is operated by a long press on the heated seat switch. Each long press of the heated seats switch changes the passenger heated seat settings in the following order: OFF - ON - OFF.

Low Power Voltage Cut Off

If a low voltage is detected the heated seats switch will power off. The heated seats will not function again until the voltage rises to a safe level.

The switch will not power back on automatically even if the voltage rises to the safe level. The ignition must be switched off, then on again to activate the heated seats.

Windscreen

Warning

Never attempt to clean or adjust the windscreen while riding the motorcycle.

Attempting to clean or adjust the windscreen while riding the motorcycle may result in loss of motorcycle control and an accident.

Warning

Make sure that the windscreen is adjusted to the same position on both sides.

Riding the motorcycle with an incorrectly adjusted windscreen could cause loss of motorcycle control and an accident.

Note:

- **The windscreen fitted to this motorcycle can be adjusted without the use of tools.**

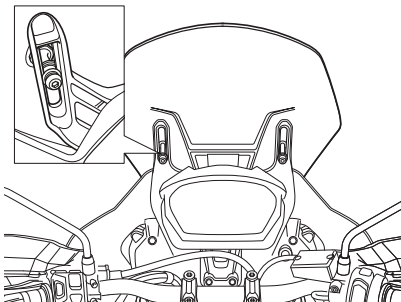

Adjusting the Windscreen

To adjust the windscreen height:

- Stand in front of the motorcycle.
- Firmly grip both sides of the top of the windscreen.
- Pull the windscreen forwards slightly to release the tension in the mountings.
- Slide the windscreen up or down to the required height.
- Release the windscreen.

For windscreen cleaning information, see page **192**.

General Information

Tool Kit and Owner's Handbook

The tool kit is located under the passenger seat and is secured with a rubber strap.

The Owner's Handbook assembly can be stored in a slot in the base of the passenger seat.

Helmet Hook

Warning

Never ride the motorcycle with helmet(s) secured to the helmet hook.

Riding the motorcycle with helmet(s) secured to the helmet hook may cause the motorcycle to become unstable leading to loss of control and an accident.

Caution

Do not allow helmets to rest against a hot silencer.

The helmet may be damaged.

A helmet can be secured to the motorcycle using the helmet hook located on the left hand side of the motorcycle, beneath the passenger seat.

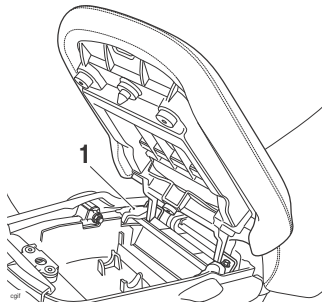

1. Helmet hook

To attach a helmet to the motorcycle:

- Remove the passenger seat.
- Loop the helmet chin strap over the hook.
- Make sure that the flat area above the hook is not obstructed by the helmet strap, as this will prevent the passenger seat engaging correctly.

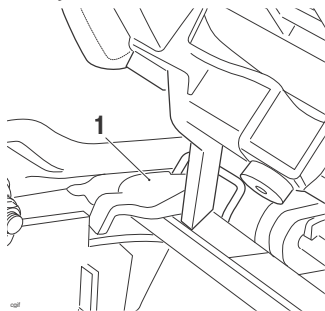

1. Helmet hook flat area

To secure the helmet, refit the seat and lock into position.

Electrical Accessory Socket

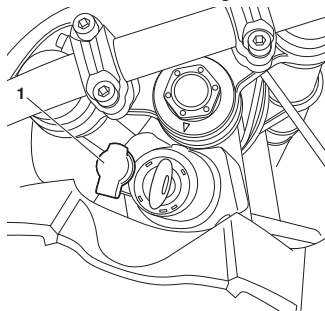

1. Ignition switch socket (all models)

All models have a socket located next to the ignition switch.

The sockets will provide a 12 Volt electrical supply.

The electrical accessory socket circuit is protected by the specified fuse shown in the fuse chart on page **178**.

To protect the battery from excessive discharge while using fitted electrical accessories, the combined total current which may be drawn through the electrical accessory sockets is five Amps.

A plug, suitable for use with the electrical accessory sockets, is available from your authorised Triumph dealer.

General Information

Universal Serial Bus (USB) Socket

Warning

The USB socket is not waterproof unless the waterproof cap is installed. Do not connect electronic devices whilst it is raining.

Water in the USB socket could lead to an electrical problem, resulting in motorcycle damage, loss of motorcycle control and an accident.

A Universal Serial Bus (USB) socket is provided, located under the passenger seat. The connector provides a 5 Volt, 2 Amp power supply which is suitable for charging electronic devices such as mobile phones, cameras and GPS devices.

To access the USB socket:

- Remove the passenger seat.
- Remove the cap from the USB socket.
- Connect your device using a suitable USB cable, then stow the device and USB cable in the space available under the passenger seat.

Caution

Make sure that all electronic devices and cables are safely secured under the seat when riding.

Make sure there is sufficient space surrounding any electronic devices for the seat to close without causing any damage to the electronic device or the motorcycle.

- Fit the passenger seat, making sure that the device or USB cable is not trapped.
- Turn the ignition on and start the engine.

Caution

Do not leave the ignition switch in the ON position unless the engine is running as this will discharge the battery.

- When your device has finished charging, remove the passenger seat and disconnect the device.
- Refit the USB socket cap and refit the passenger seat.

Note:

- The USB socket is protected by a chassis ECM, which will automatically cut power to the socket in the event of an overload.
- Power can be restored to the USB socket by turning the ignition switch off then on again, provided that the socket is not still overloaded.

Luggage Systems

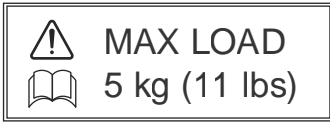

Expedition Aluminium Panniers (if fitted)

The Expedition Aluminium Panniers and mounting rails are available as an accessory option.

For more details on the Expedition Aluminium Panniers and all other luggage solutions available, contact your authorised Triumph dealer or visit www.triumph.co.uk.

Note:

- The same procedure can be followed to remove and mount the left hand or the right hand panniers.
- The pannier lock barrel has two positions as shown.

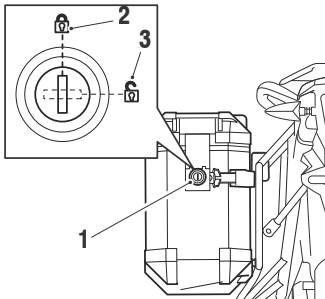

1. Lock barrel
2. Lock position
3. Unlock position

Pannier Removal

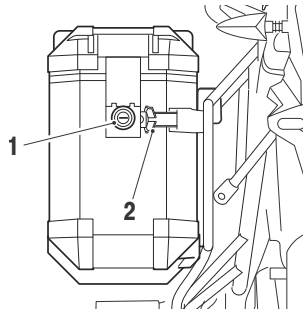

1. Lock (left hand pannier shown)
2. Locking mechanism release lever

To unlock and remove the pannier from the pannier mountings:

- Turn the key to the UNLOCK position.
- Whilst supporting the pannier, pull the locking mechanism release lever to detach the pannier from the upper mounting points.
- Lift the pannier free from the lower mounting points.

Pannier Installation

To install each pannier:

- Insert the key into the lock.
- Turn the key to the UNLOCK position.

General Information

Note:

- The left hand and right hand panniers must be mounted to the correct side of the motorcycle.
- When mounting the panniers, make sure that the lock barrels are facing towards the rear of the motorcycle.
- Position the pannier onto the lower pannier mounting points as shown below.

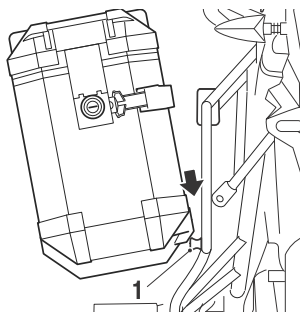

1. Lower pannier mounting point

- Locate the pannier's locking mechanism to the upper mounting points and press the pannier inwards to engage the locking mechanism.

Note:

- An audible click can be heard when the pannier's upper mounting locking mechanism is engaged.
- Two status indicators are also provided on the top of the upper mounting point. The status indicators will change colour from red to green when the locking mechanism is correctly engaged.
- If the status indicators remain red, the upper mounting locking mechanism is not correctly engaged.

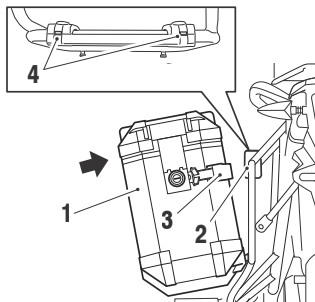

1. Pannier
2. Upper mounting point
3. Locking mechanism
4. Status indicators

- Lock the pannier to the rail by turning the key to the LOCK position.
- Remove the key.

Warning

An incorrectly mounted pannier may detach whilst riding, resulting in a dangerous riding condition.

Before riding, always make sure that both panniers are mounted correctly. Make sure that the status indicators located on the top of the pannier's upper mounting points are green and that the lock barrel is turned to the LOCK position and the key removed.

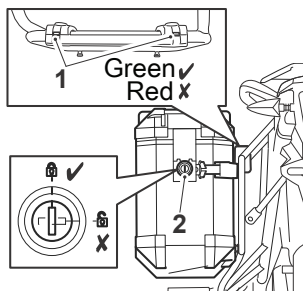

1. Locking mechanism status indicators
2. Lock barrel

A pannier that detaches whilst riding may cause loss of motorcycle control and an accident and/or injury to other road users.

Pannier Operation

To unlock and open the pannier:

- Insert the key and turn it to the UNLOCK position.
- Release the pannier lid latch. The lid can then be opened.

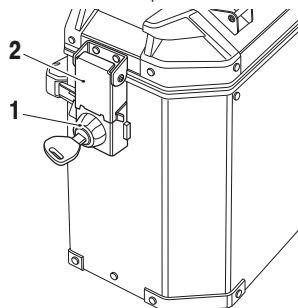

1. Lock barrel - unlock position
2. Pannier lid latch

- The lid can also be removed from the pannier.
- To remove the lid, detach the retaining straps as shown below.

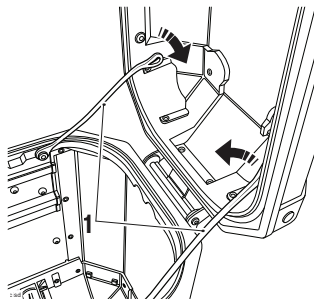

1. Retaining straps

- Press downwards on the quick release mechanism for the pannier lid hinge.

General Information

- Slide the lid down and to the rear to release the pannier lid hinge. The lid can now be removed from the pannier.

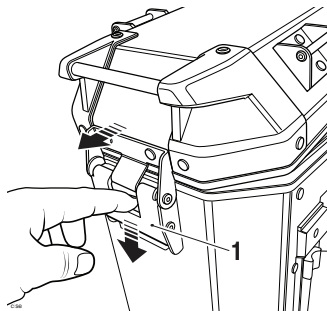

1. Pannier lid hinge quick release mechanism

To install the pannier lid:

- Press downwards on the quick release mechanism and relocate the pannier lid hinge.
- Release the quick release mechanism, making sure that the hinge is correctly engaged.
- Attach the retaining straps to the pannier lid.

To close and lock the pannier:

- Close the lid and secure with the pannier lid latch.
- Turn the key to the LOCK position and remove it.

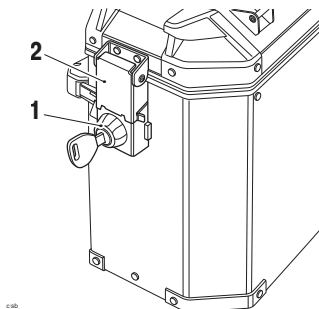

1. Lock barrel - lock position
2. Pannier lid latch

Warning

The maximum safe load for each pannier is 5 kg (11 lbs).

Never exceed this loading limit as this may cause the motorcycle to become unstable leading to loss of motorcycle control and an accident.

Warning

The Expedition Aluminium Panniers are designed to be fitted as a pair.

Never ride the motorcycle with only one pannier installed.

Riding the motorcycle with one pannier installed may cause the motorcycle to become unstable leading to loss of motorcycle control and an accident.

Warning

After fitting or removing the panniers, operate the motorcycle in a safe area free from traffic to gain familiarity with the new handling characteristics.

Operation when not familiar with the new characteristics of the motorcycle may result in loss of motorcycle control and an accident.

For more information refer to the Accessories, Loading and Passengers section on page **130**.

Triumph Accessory D-lock Storage

Space is provided under the passenger seat to store a Triumph accessory D-lock (available from your Triumph dealer).

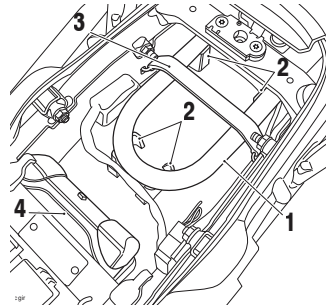

1. **Lock U-section**
2. **Rear mudguard lock support features**
3. **Tool kit strap (tool kit not shown - removed for clarity)**
4. **Lock body**

To secure the lock:

- Release the strap securing the tool kit.
- Position the U-section of the lock to the rear mudguard tray support features, making sure that the open end faces towards the rear of the motorcycle.
- Secure the U-section using the tool kit strap.
- Position the lock body to the tray in the rear mudguard.
- Refit the tool kit.
- Refit the passenger seat to secure the lock body.

General Information

Running-In



Running-in is the name given to the process that occurs during the first hours of a new vehicle's operation.

In particular, internal friction in the engine will be higher when components are new. Later on, when continued operation of the engine has ensured that the components have 'bedded in', this internal friction will be greatly reduced.

A period of careful running-in will ensure lower exhaust emissions, and will optimise performance, fuel economy and longevity of the engine and other motorcycle components.

During the first 500 miles (800 km):

- Do not use full throttle;
- Avoid high engine speeds at all times;
- Avoid riding at one constant engine speed, whether fast or slow, for a long period of time;
- Avoid aggressive starts, stops, and rapid accelerations, except in an emergency;
- Do not ride at speeds greater than 3/4 of maximum speed.

From 500 to 1,000 miles (800 to 1,500 km):

- Engine speed can gradually be increased to the rev limit for short periods.

Both during and after running-in has been completed:

- Do not overrev the engine when cold;
- Do not let the engine labour. Always downshift before the engine begins to 'struggle';
- Do not ride with engine speeds unnecessarily high. Changing up a gear helps reduce fuel consumption, reduces noise and helps to protect the environment.

Daily Safety Checks



Warning

Failure to perform these checks every day before you ride may result in serious motorcycle damage or an accident causing serious injury or death.



DAILY SAFETY CHECKS AND SEAT CARE
CONTRÔLES DE SÉCURITÉ QUOTIDIEN ET NETTOYAGE DE LA SELLE
COMPROBACIONES DIARIAS Y EL MANTENIMIENTO DE SU ASIENTO
DAGELIJKE VEILIGHEIDSKONTROLES EN ZADELONDERHOUD
DÄGLIGA SÄKERHETSKONTROLLER OCH VÅRD AV SADEL
CONTROLLI DI SICUREZZA GIORNALIERI E PULIZIA SELLA
日常安全点検とシートのお手入れ

Check the following items each day before you ride. The time required is minimal, and these checks will help ensure a safe, reliable ride.

If any irregularities are found during these checks, refer to the Maintenance and Adjustment section or see your authorised Triumph dealer for the action required to return the motorcycle to a safe operating condition.

Check:

Fuel: Adequate supply in tank, no fuel leaks (page 97).

Engine Oil: Correct level on dipstick. Add correct specification oil as required. No leaks from the engine or oil cooler (page 140).

Drive Chain: Correct adjustment (page 148).

Tyres/Wheels: Correct inflation pressures (when cold). Tread depth/wear, tyre/wheel damage, punctures etc. (page 167).

Nuts, Bolts, Fasteners: Visually check that steering and suspension components, axles, and all controls are properly tightened or fastened. Inspect all areas for loose/damaged fixings.

Steering Action: Smooth but not loose from lock to lock. No binding of any of the control cables (page 157).

Brakes: Pull the brake lever and push the brake pedal to check for correct resistance. Investigate any lever/pedal where the travel is excessive before meeting resistance, or if either control feels spongy in operation (page 152).

Brake Pads: There should be more than 1.5 mm of friction material remaining on all the brake pads (page 152).

Brake Fluid Levels: No brake fluid leakage. Brake fluid levels must be between the MAX and MIN marks on both reservoirs (page 154).

Front Forks: Smooth action. No leaks from fork seals (page 158).

Throttle: Make sure that the throttle grip returns to the idle position without sticking (page 87).

Clutch: Smooth operation and correct cable free play (page 147).

Coolant: No coolant leakage. Check the coolant level in the expansion tank (when the engine is cold) (page 144).

Electrical Equipment: All lights and the horn function correctly (page 180).

Engine Stop: Stop switch turns the engine off (page 119).

Stands: Returns to the fully up position by spring tension. Return springs not weak or damaged (page 102).

HOW TO RIDE THE MOTORCYCLE

Table of Contents

Stopping the Engine.....	119
Starting the Engine.....	120
Moving Off.....	121
Changing Gears.....	122
Braking.....	123
ABS (Anti-Lock Brake System).....	125
Parking.....	127
Considerations for High Speed Operation.....	128

Stopping the Engine

Tiger 800 XR Model Only

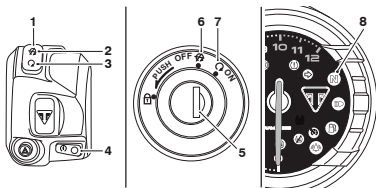

1. Engine stop switch
2. STOP position
3. RUN position
4. Starter button
5. Ignition switch
6. OFF position
7. ON position
8. Neutral indicator light

All Models except Tiger 800 XR

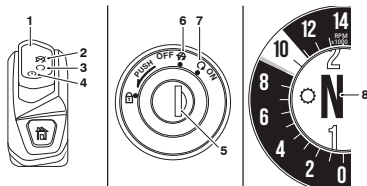

1. Engine stop switch
2. STOP position
3. RUN position
4. Starter button
5. Ignition switch
6. OFF position
7. ON position
8. Neutral indicator light

To stop the engine:

- Close the throttle completely.
- Select neutral.
- Turn the ignition switch OFF.
- Select first gear.
- Support the motorcycle on a firm, level surface with the side stand.
- Lock the steering.

Caution

The engine should normally be stopped by turning the ignition switch to the OFF position. The engine stop switch is for emergency use only.

Do not leave the ignition switched on with the engine stopped.

Electrical damage may result.

How to Ride the Motorcycle

Starting the Engine

Warning

Never start the engine or run the engine in a confined area.

Exhaust fumes are poisonous and can cause loss of consciousness and death within a short period of time.

Always operate your motorcycle in the open-air or in an area with adequate ventilation.

Caution

Do not operate the starter continuously for more than five seconds as the starter motor will overheat and the battery will become discharged. Wait 15 seconds between each operation of the starter to allow for cooling and recovery of battery power.

Do not let the engine idle for long periods as this may lead to overheating which will cause damage to the engine.

Caution

If the low oil pressure warning light/message illuminates after starting the engine, stop the engine immediately and investigate the cause.

Running the engine with low oil pressure will cause severe engine damage.

To start the engine:

- Check that the engine stop switch is in the RUN position.
- Make sure that the transmission is in neutral.
- Turn the ignition switch ON.

Note:

- **When the ignition is switched on, the tachometer needle will quickly sweep from zero to maximum and then return to zero. The instrument warning lights will illuminate and will then go off (except those which normally remain on until the engine starts – see page 57). It is not necessary to wait for the needle to return to zero before starting the engine.**
- **A transponder is fitted within the key to turn off the engine immobiliser. To make sure that the immobiliser functions correctly, always have only one of the ignition keys near the ignition switch. Having two ignition keys near the switch may interrupt the signal between the transponder and the engine immobiliser. In this situation the engine immobiliser will remain active until one of the ignition keys is removed.**
- Pull the clutch lever fully into the handlebar.
- Leaving the throttle fully closed, push the starter button until the engine starts.

The motorcycle is equipped with starter lockout switches. The switches prevent the electric starter from operating when the transmission is not in neutral with the side stand down.

If the side stand is extended whilst the engine is running, and the transmission is not in neutral then the engine will stop regardless of clutch position.

Moving Off

To move the motorcycle:

- Pull in the clutch lever and select first gear.
- Open the throttle a little and let out the clutch lever slowly.
- As the clutch starts to engage, open the throttle a little more, allowing enough engine speed to avoid stalling.

How to Ride the Motorcycle

Changing Gears

! Warning

Take care to avoid opening the throttle too far or too fast in any of the lower gears as this can lead to the front wheel lifting from the ground (pulling a wheelie) and to the rear tyre breaking traction (wheel spin).

Always open the throttle cautiously, particularly if you are unfamiliar with the motorcycle, as a wheelie or loss of traction will cause loss of motorcycle control and an accident.

! Warning

Do not change to a lower gear at speeds that will cause excessive engine rpm (r/min). This can lock the rear wheel causing loss of control and an accident. Engine damage may also be caused.

Changing down the gears should be done so that low engine speeds will be ensured.

To change gears:

- Close the throttle while pulling in the clutch lever.
- Change into the next higher or lower gear.
- Open the throttle part way, while releasing the clutch lever.
- Always use the clutch when changing gear.

Note:

- **The gear change mechanism is the positive stop type. This means that, for each movement of the gear change pedal, you can only select each gear, one after the other, in ascending or descending order.**

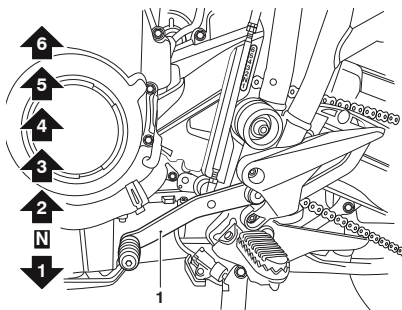

1. Gear change pedal

How to Ride the Motorcycle

Braking

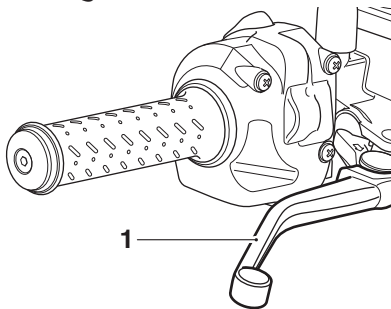

1. Front brake lever

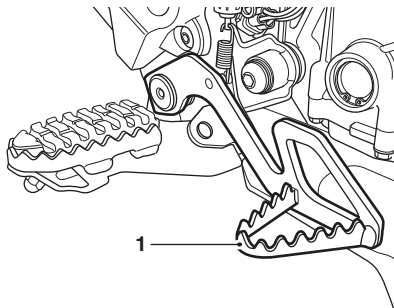

1. Rear brake pedal

Warning

When braking, observe the following:

Close the throttle completely, leaving the clutch engaged to allow the engine to help slow down the motorcycle.

Change down one gear at a time such that the transmission is in first gear when the motorcycle comes to a complete stop.

When stopping, always apply both brakes at the same time. Normally the front brake should be applied a little more than the rear.

Change down or fully disengage the clutch as necessary to keep the engine from stalling.

Never lock the brakes, as this may cause loss of control of the motorcycle and an accident.

Warning

For emergency braking, disregard down changing, and concentrate on applying the front and rear brakes as hard as possible without skidding. Riders should practice emergency braking in a traffic-free area.

Triumph strongly recommends that all riders take a course of instruction, which includes advice on safe brake operation. Incorrect brake technique could result in loss of control and an accident.

How to Ride the Motorcycle

Warning

For your safety, always exercise extreme caution when braking, accelerating or turning as any incautious action can cause loss of control and an accident. Independent use of the front or rear brakes reduces overall braking performance. Extreme braking may cause either wheel to lock, reducing control of the motorcycle and causing an accident.

When possible, reduce speed or brake before entering a turn as closing the throttle or braking in mid-turn may cause wheel slip leading to loss of control and an accident.

When riding in wet or rainy conditions, or on loose surfaces, the ability to manoeuvre and stop will be reduced. All of your actions should be smooth under these conditions. Sudden acceleration, braking or turning may cause loss of control and an accident.

Warning

When descending a long, steep gradient or mountain pass, make use of the engine's braking effect by down changing and use both front and rear brakes intermittently.

Continuous brake application or use of the rear brake only can overheat the brakes and reduce their effectiveness leading to loss of motorcycle control and an accident.

Warning

Riding with your foot on the brake pedal or your hands on the brake lever may actuate the brake light, giving a false indication to other road users. It may also overheat the brake, reducing braking effectiveness leading to loss of motorcycle control and an accident.

Warning

Do not coast with the engine switched off, and do not tow the motorcycle.

The transmission is pressure-lubricated only when the engine is running.

Inadequate lubrication may cause damage or seizure of the transmission, which can lead to sudden loss of motorcycle control and an accident.

Warning

When using the motorcycle on loose, wet, or muddy roads, braking effectiveness will be reduced by dust, mud or moisture collecting on the brakes.

Always brake earlier in these conditions to ensure brake surfaces are cleaned by the braking action.

Riding the motorcycle with brakes contaminated with dust, mud or moisture may cause loss of control and an accident.

ABS (Anti-Lock Brake System)

Warning

ABS helps prevent the wheels from locking, therefore maximising the effectiveness of the braking system in emergencies and when riding on slippery surfaces. The potentially shorter braking distances ABS allows under certain conditions are not a substitute for good riding practice.

Always ride within the legal speed limit.

Never ride without due care and attention and always reduce speed in consideration of weather, road and traffic conditions.

Take care when cornering. If the brakes are applied in a corner, ABS will not be able to counteract the weight and momentum of the motorcycle. This can result in loss of control and an accident.

Under some circumstances it is possible that a motorcycle equipped with ABS may require a longer stopping distance than an equivalent motorcycle without ABS.

ABS Warning Light



When the ignition switch is turned to the ON position, it is normal for the ABS warning light to flash on and off (see page 57). If the ABS warning light is constantly illuminated it indicates that the ABS function is not available because:

- The ABS has been disabled by the rider.
- The ABS has a malfunction that requires investigation.

If the indicator light becomes illuminated while riding, it indicates that the ABS has a malfunction that requires investigation.

Note:

- **Normally, the rider will perceive ABS operation as a harder feel or a pulsation of the brake lever and pedal. As the ABS is not an integrated braking system and it does not control both the front and rear brake at the same time, this pulsation may be felt in the lever, the pedal or both.**
- **The ABS may be activated by sudden upward or downward changes in the road surface.**

How to Ride the Motorcycle

Warning

If the ABS is not functioning, the brake system will continue to function as a non-ABS braking system.

Do not continue to ride for longer than is necessary with the indicator light illuminated.

In the event of a fault, contact an authorised Triumph dealer as soon as possible to have the fault checked and rectified. In this situation, braking too hard will cause the wheels to lock resulting in loss of control and an accident.

Warning

The ABS system operates by comparing the relative speed of the front and rear wheels.

Use of non-recommended tyres can affect wheel speed and cause the ABS function not to operate, potentially leading to loss of control and an accident in conditions where the ABS would normally function.

Warning

The ABS warning light will illuminate when the rear wheel is driven at high speed for more than 30 seconds when the motorcycle is on a stand. This reaction is normal.

When the ignition is switched off and the motorcycle is restarted, the warning light will illuminate until the motorcycle reaches a speed exceeding 19 mph (30 km/h).

How to Ride the Motorcycle

Parking

! Warning

Petrol is extremely flammable and can be explosive under certain conditions.

If parking inside a garage or other structure, be sure it is well ventilated and the motorcycle is not close to any source of flame or sparks. This includes any appliance with a pilot light.

Failure to follow the above advice may cause a fire resulting in damage to property or personal injury.

! Warning

The engine and exhaust system will be hot after riding. DO NOT park where pedestrians and children are likely to touch the motorcycle.

Touching any part of the engine or exhaust system when hot may cause unprotected skin to become burnt.

! Warning

Do not park on a soft or on a steeply inclined surface.

Parking under these conditions may cause the motorcycle to fall over causing damage to property and personal injury.

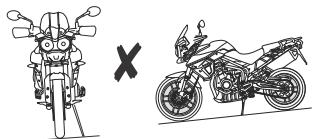
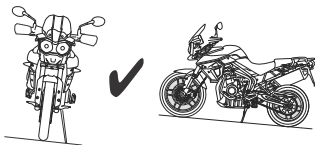

To park the motorcycle:

- Select neutral and turn the ignition switch to the OFF position.
- Lock the steering to help prevent theft.
- Always park on a firm, level surface to prevent the motorcycle from falling. This is particularly important when parking off-road.
- When parking on a hill, always park facing uphill to prevent the motorcycle from rolling off the stand. Engage first gear to prevent the motorcycle from moving.
- On a lateral (sideways) incline, always park such that the incline naturally pushes the motorcycle towards the side stand.
- Do not park on a lateral (sideways) incline of greater than 6° and never park facing downhill.

How to Ride the Motorcycle

Considerations for High Speed Operation

Warning

This Triumph motorcycle should be operated within the legal speed limits for the particular road travelled.

Operating a motorcycle at high speeds can be potentially dangerous since the time available to react to given traffic situations is greatly reduced as road speed increases.

Always reduce speed in consideration of weather and traffic conditions.

Warning

Only operate this Triumph motorcycle at high speed in closed-course on-road competition or on closed-course racetracks. High speed operation should only then be attempted by riders who have been instructed in the techniques necessary for high speed riding and are familiar with the motorcycle's characteristics in all conditions.

High speed operation in any other circumstances is dangerous and will lead to loss of motorcycle control and an accident.

Warning

The handling characteristics of a motorcycle at high speed may vary from those you are familiar with at legal road speeds. Do not attempt high speed operation unless you have received sufficient training and have the required skills as a serious accident may result from incorrect operation.

Warning

The items listed below are extremely important and must never be neglected. A problem, which may not be noticed at normal operating speeds, may be greatly exaggerated at high speeds.

General

Make sure that the motorcycle has been maintained according to the scheduled maintenance chart.

Steering

Check that the handlebar turns smoothly without excessive free play or tight spots. Make sure that the control cables do not restrict the steering in any way.

Luggage

Make sure that any luggage containers are closed, locked and securely fitted to the motorcycle.

Brakes

Check that the front and rear brakes are functioning correctly.

Tyres

High speed operation is hard on tyres, and tyres that are in good condition are crucial to riding safely. Examine their overall condition, inflate to the correct pressure (when the tyres are cold), and check the wheel balance. Securely fit the valve caps after checking tyre pressures. Observe the information given in the maintenance and specification sections on tyre checking and tyre safety.

Fuel

Have sufficient fuel for the increased fuel consumption that will result from high speed operation.



Caution

In many countries, the exhaust system for this model is fitted with a catalytic converter to help reduce exhaust emission levels.

The catalytic converter can be permanently damaged if the motorcycle is allowed to run out of fuel or if the fuel level is allowed to get very low.

Always make sure you have adequate fuel for your journey.

Engine Oil

Check that the engine oil level is correct. Make sure that the correct grade and type of oil is used when topping up.

Drive Chain

Make sure that the drive chain is correctly adjusted and lubricated. Inspect the chain for wear and damage.

Coolant

Check that the coolant level is at the upper level line in the expansion tank. Always check the level with the engine cold.

Electrical Equipment

Make sure that all electrical equipment such as the headlight, rear/brake light, direction indicators and horn all work correctly.

Miscellaneous

Visually check that all fixings are tight.

ACCESSORIES, LOADING AND PASSENGERS

The addition of accessories and carriage of additional weight can affect the motorcycle's handling characteristics causing changes in stability and necessitating a reduction in speed. The following information has been prepared as a guide to the potential hazards of adding accessories to a motorcycle and carrying passengers and additional loads.

Accessories

Warning

Do not install accessories or carry luggage that impairs the control of the motorcycle.

Make sure that you have not adversely affected any lighting component, road clearance, banking capability (i.e. lean angle), control operation, wheel travel, front fork movement, visibility in any direction, or any other aspect of the motorcycle's operation.

Warning

Never ride an accessory equipped motorcycle, or a motorcycle carrying a payload of any kind, at speeds above 80 mph (130 km/h). In either/both of these conditions, speeds in excess of 80 mph (130 km/h) should not be attempted even where the legal speed limit permits this.

The presence of accessories and/or payload will cause changes in the stability and handling of the motorcycle.

Failure to allow for changes in motorcycle stability may lead to loss of motorcycle control and an accident. When riding at high speed, always be aware that various motorcycle configuration and environmental factors can adversely affect the stability of your motorcycle. For example:

- Incorrectly balanced loads on both sides of the motorcycle
- Incorrectly adjusted front and rear suspension settings
- Incorrectly adjusted tyre pressures
- Excessively or unevenly worn tyres
- Side winds and turbulence from other vehicles
- Loose clothing

Accessories, Loading and Passengers

Warning Continued

Remember that the 80 mph (130 km/h) absolute limit will be reduced by the fitting of non-approved accessories, incorrect loading, worn tyres, overall motorcycle condition and poor road or weather conditions

Warning

Owners should be aware that the only approved parts, accessories and conversions for any Triumph motorcycle are those which carry official Triumph approval and are fitted to the motorcycle by an authorised dealer.

In particular, it is extremely hazardous to fit or replace parts or accessories whose fitting requires the dismantling of, or addition to, either the electrical or fuel systems and any such modification could cause a safety hazard.

The fitting of any non-approved parts, accessories or conversions may adversely affect the handling, stability or other aspect of the motorcycle operation that may result in an accident causing injury or death.

Triumph does not accept any liability whatsoever for defects caused by the fitting of non-approved parts, accessories or conversions or the fitting of any approved parts, accessories or conversions by non-approved personnel.

Loading

Warning

Incorrect loading may result in an unsafe riding condition leading to an accident.

Always make sure that any loads carried are evenly distributed on both sides of the motorcycle. Make sure that the load is correctly secured such that it will not move around while the motorcycle is in motion.

Evenly distribute the load within each pannier. Pack heavy items at the bottom and on the inboard side of the pannier.

Always check the load security regularly (though not while the motorcycle is in motion) and make sure that the load does not extend beyond the rear of the motorcycle.

Never exceed the maximum vehicle loading weight of 222 kg (489 lbs).

Warning

The maximum safe load for each pannier is 5 kg (11lbs).

Never exceed this loading limit as this may cause the motorcycle to become unstable leading to loss of motorcycle control and an accident.

Accessories, Loading and Passengers

Warning

Never attempt to store any items between the frame and the fuel tank. This can restrict the steering and will cause loss of control leading to an accident.

Weight attached to the handlebar or front fork will increase the mass of the steering assembly and can result in loss of steering control leading to an accident.

Warning

If the passenger seat is used to carry small objects, they must not exceed 5 kg in weight, must not impair control of the motorcycle, must be securely attached and must not extend beyond the rear or sides of the motorcycle.

Carrying objects in excess of 5 kg in weight, that are insecure, impair control or extend beyond the rear or sides of the motorcycle may lead to loss of motorcycle control and an accident.

Even if small objects are correctly loaded onto the passenger seat, the maximum speed of the motorcycle must be reduced to 80 mph (130 km/h).

Passengers

Warning

The handling and braking capabilities of a motorcycle will be affected by the presence of a passenger. The rider must make allowances for these changes when operating the motorcycle with a passenger and should not attempt such operation unless trained to do so and without becoming familiar and comfortable with the changes in motorcycle operating characteristics that this brings about.

Motorcycle operation without making allowances for the presence of a passenger could lead to loss of motorcycle control and an accident.

Warning

Do not carry a passenger unless he or she is tall enough to reach the footrests provided.

A passenger who is not tall enough to reach the footrests will be unable to sit securely on the motorcycle and may cause instability leading to loss of control and an accident.

Warning

Your passenger should be instructed that he or she can cause loss of motorcycle control by making sudden movements or by adopting an incorrect seated position.

The rider should instruct the passenger as follows:

It is important that the passenger sits still while the motorcycle is in motion and does not interfere with the operation of the motorcycle.

To keep his or her feet on the passenger footrests and to firmly hold onto the grab handles or the rider's waist or hips.

Advise the passenger to lean with the rider when travelling around corners and not to lean unless the rider does so.

Warning

Do not carry animals on your motorcycle.

An animal could make sudden and unpredictable movements that could lead to loss of motorcycle control and an accident.

Warning

The handling and braking capabilities of a motorcycle will be affected by the presence of a passenger. The rider must make allowances for these changes when operating the motorcycle with a passenger and should not attempt such operation unless trained to do so and without becoming familiar and comfortable with the changes in motorcycle operating characteristics that this brings about.

Motorcycle operation without making allowances for the presence of a passenger could lead to loss of motorcycle control and an accident.

MAINTENANCE

Table of Contents

Scheduled Maintenance	136
Scheduled Maintenance Table	138
Engine Oil	140
Oil Level Inspection	140
Oil and Oil Filter Change	141
Disposal of Used Engine Oil and Oil Filters	142
Oil Specification and Grade	142
Cooling System	143
Coolant Level Inspection	144
Coolant Level Adjustment	145
Coolant Change	145
Throttle Control	146
Clutch	147
Clutch Inspection	147
Clutch Adjustment	147
Drive Chain	148
Drive Chain Lubrication	149
Drive Chain Free Movement Inspection	149
Drive Chain and Sprocket Wear Inspection	151
Brakes	152
Breaking-in New Brake Pads and Discs	152
Brake Pad Wear Compensation	153
Disc Brake Fluid	153
Brake Fluid Level Inspection and Adjustment	154
Brake Light Switches	156
Steering Inspection	157
Front Suspension	158
Front Suspension Setting Charts	159
Front Suspension Adjustment	160
Rear Suspension	163
Rear Suspension Adjustment	163
Rear Suspension Setting Charts	165
Bank Angle Indicators	167
Tyres	167
Tyre Inflation Pressures	169
Tyre Pressure Monitoring System (if fitted)	169

Tyre Wear	169
Minimum Recommended Tread Depth	170
Tyre Replacement	170
Tyre Pressure Monitoring System (Only on models fitted with TPMS)	173
Battery	173
Battery Removal	174
Battery Disposal	175
Battery Maintenance	175
Battery Discharge	175
Battery Discharge During Storage and Infrequent Use of the Motorcycle	175
Battery Charging	176
Battery Installation	176
Fuses	178
Fuse Identification	178
Headlights	180
Headlight Adjustment	181
Bulb Replacement	183
Headlight Bulb Replacement	183
Daytime Running Light (DRL) (if fitted)	185
Fog Lights (if fitted)	185
Rear Light/Licence Plate Light	185
Direction Indicator Lights	185

Maintenance

Scheduled Maintenance

Warning

Triumph Motorcycles cannot accept any responsibility for damage or injury resulting from incorrect maintenance or improper adjustment carried out by the owner.

Since incorrect or neglected maintenance can lead to a dangerous riding condition, always have an authorised Triumph dealer carry out the scheduled maintenance of this motorcycle.

Warning

All maintenance is vitally important and must not be neglected. Incorrect maintenance or adjustment may cause one or more parts of the motorcycle to malfunction. A malfunctioning motorcycle may lead to loss of control and an accident.

Weather, terrain and geographical location affect maintenance. The maintenance schedule should be adjusted to match the particular environment in which the vehicle is used and the demands of the individual owner.

Special tools, knowledge and training are required in order to correctly carry out the maintenance items listed in the scheduled maintenance chart. Only an authorised Triumph dealer will have this knowledge and equipment.

Since incorrect or neglected maintenance can lead to a dangerous riding condition, always have an authorised Triumph dealer carry out the scheduled maintenance of this motorcycle.

To maintain the motorcycle in a safe and reliable condition, the maintenance and adjustments outlined in this section must be carried out as specified in the schedule of daily checks, and also in line with the scheduled maintenance chart. The information that follows describes the procedures to follow when carrying out the daily checks and some simple maintenance and adjustment items.

Scheduled maintenance may be carried out by your authorised Triumph dealer in three ways; annual maintenance, mileage based maintenance or a combination of both, depending on the mileage the motorcycle travels each year.

1. Motorcycles travelling less than 6,000 miles (10,000 km) per year must be maintained annually. In addition to this, mileage based items require maintenance at their specified intervals, as the motorcycle reaches this mileage.
2. Motorcycles travelling approximately 6,000 miles (10,000 km) per year must have the annual maintenance and the specified mileage based items carried out together.
3. Motorcycles travelling more than 6,000 miles (10,000 km) per year must have the mileage based items maintained as the motorcycle reaches the specified mileage. In addition to this, annual based items will require maintenance at their specified annual intervals.

In all cases maintenance must be carried out at or before the specified maintenance intervals shown. Consult an authorised Triumph dealer for advice on which maintenance schedule is most suitable for your motorcycle.

Triumph Motorcycles cannot accept any responsibility for damage or injury resulting from incorrect maintenance or improper adjustment.

Maintenance

Scheduled Maintenance Table

Operation Description	Odometer Reading in Miles (km) or Time Period, whichever comes first					
		First Service	Annual Service	Mileage Based Service		
	Every	500 (800) one month	Year	6,000 and 18,000 (10,000 and 30,000)	12,000 (20,000)	24,000 (40,000)
Lubrication						
Engine oil - renew	-	*	*	*	*	*
Engine and oil filter - renew	-	*	*	*	*	*
Engine and oil cooler - check for leaks	Day	*	*	*	*	*
Fuel System and Engine Management						
Fuel system - check for leaks, chafing etc.	Day	*	*	*	*	*
Throttle body plate (butterfly) - check/clean	-			*	*	*
Autoscan - carry out a full Autoscan using the Triumph diagnostic tool (print a customer copy)	-	*	*	*	*	*
ABS modulator - check for stored DTCs	-	*	*	*	*	*
Secondary air injection system - check/clean	-				*	*
Air cleaner - renew	-				*	*
Throttle bodies - balance	-			*	*	*
Fuel hoses - renew	Every four years, regardless of mileage					
Evaporative loss hoses* - renew	Every four years, regardless of mileage					
Ignition System						
Spark plugs - check	-			*		
Spark plugs - renew	-				*	*
Cooling System						
Cooling system - check for leaks	Day	*	*	*	*	*
Coolant level - check/adjust	Day	*	*	*	*	*
Coolant - renew	Every three years, regardless of mileage					
Engine						
Clutch cable - check/adjust	Day	*	*	*	*	*
Valve clearances - check/adjust	-				*	*
Camshaft timing - adjust	First 12,000 miles (20,000 km) service only					
Wheels and Tyres						
Wheels - inspect for damage	Day	*	*	*	*	*
Wheel bearings - check for wear/smooth operation	-	*	*	*	*	*
Wheels - check wheels for broken or damaged spokes and check spoke tightness (if fitted)	Day	*	*	*	*	*
Tyre wear/tyre damage - check	Day	*	*	*	*	*
Tyre pressures - check/adjust	Day	*	*	*	*	*
Electrical						
Lights, instruments and electrical systems - check	Day	*	*	*	*	*
Steering and suspension						
Steering - check for free operation	Day	*	*	*	*	*
Forks - check for leaks/smooth operation	Day	*	*	*	*	*

Operation Description	Odometer Reading in Miles (km) or Time Period, whichever comes first					
		First Service	Annual Service	Mileage Based Service		
	Every	500 (800) one month	Year	6,000 and 18,000 (10,000 and 30,000)	12,000 (20,000)	24,000 (40,000)
Fork oil - renew	-					*
Headstock bearings - check/adjust	-		*	*	*	*
Headstock bearings - lubricate	-				*	*
Rear suspension linkage - check/lubricate	-				*	*
Brakes						
Brake pads - check wear levels	Day	*	*	*	*	*
Brake master cylinders - check for fluid leaks	Day	*	*	*	*	*
Brake calipers - check for fluid leaks and seized pistons	Day	*	*	*	*	*
Brake fluid levels - check	Day	*	*	*	*	*
Brake fluid - renew		Every two years, regardless of mileage				
Drive Chain						
Drive chain slack - check/adjust	Day	*	*	*	*	*
Drive chain - wear check		Every 500 miles (800 km)				
Drive chain - lubricate		Every 200 miles (300 km)				
Drive chain rubbing strip - check	Day	*	*	*	*	*
Drive chain rubbing strip - renew	-			*	*	*
General						
Fasteners - inspect visually for security	Day	*	*	*	*	*
Bank angle indicators - inspect visually for wear	Day	*	*	*	*	*
Accessory rack sliding carriage - check for correct operation†	-		*	*	*	*
Side stand - check operation	Day	*	*	*	*	*
Centre stand - check operation	Day	*	*	*	*	*
Centre stand flanged sleeves - check/clean/grease	-		*	*	*	*
Accessory pannier link mechanism - check for correct operation and adjustment‡	-		*	*	*	*
* Evaporative system fitted to models for certain markets only.						
† Only if fitted.						

Maintenance

Engine Oil



Warning

Motorcycle operation with insufficient, deteriorated, or contaminated engine oil will cause accelerated engine wear and may result in engine or transmission seizure. Seizure of the engine or transmission may lead to sudden loss of control and an accident.

In order for the engine, transmission, and clutch to function correctly, maintain the engine oil at the correct level, and change the oil and oil filter in accordance with scheduled maintenance requirements.

Oil Level Inspection

Warning

Never start the engine or run the engine in a confined area.

Exhaust fumes are poisonous and can cause loss of consciousness and death within a short period of time.

Always operate your motorcycle in the open-air or in an area with adequate ventilation.

Caution

Running the engine with insufficient oil will cause engine damage. If the low oil pressure indicator remains on, stop the engine immediately and investigate the cause.

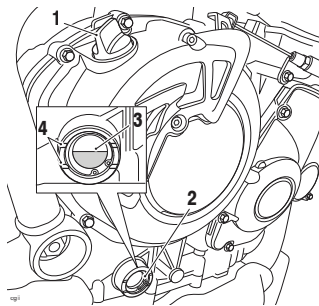

1. **Filler**
2. **Sight glass**
3. **Oil level (correct level shown)**
4. **Crankcase oil level lines**

To inspect the oil level:

- Start the engine and run at idle for approximately five minutes.
- Stop the engine, then wait for at least three minutes for the oil to settle.
- Note the oil level visible in the sight glass.
- When correct, oil should be visible in the sight glass at a point midway between the upper (maximum) and lower (minimum) horizontal lines marked on the crankcase.

Note:

- **An accurate indication of the level of oil in the engine is only shown when the engine is at normal operating temperature and the motorcycle is upright (not on the side stand).**
- When correct, oil should be visible in the sight glass at a point midway between the upper (maximum) and lower (minimum) horizontal lines marked on the crankcase.
- If it is necessary to top up the oil level, remove the filler plug and add oil, a little at a time, until the level registered in the sight glass is correct.

Once the correct level is reached, fit and tighten the filler plug.

Oil and Oil Filter Change

Warning

Prolonged or repeated contact with engine oil can lead to skin dryness, irritation and dermatitis. In addition, used engine oil contains harmful contamination that can lead to skin cancer.

Always wear suitable protective clothing and avoid skin contact with used oil.

The engine oil and filter must be replaced in accordance with scheduled maintenance requirements.

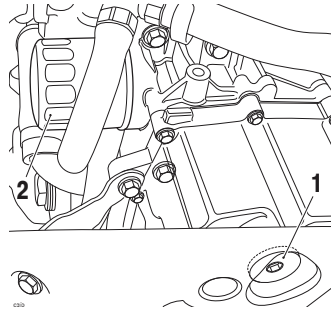

1. **Oil drain plug**
2. **Oil filter**

To change the oil and oil filter:

- Warm up the engine thoroughly, and then stop the engine and secure the motorcycle in an upright position on level ground.
- Place an oil drain pan beneath the engine.
- Remove the oil drain plug.

Warning

The oil may be hot to the touch.

Avoid contact with the hot oil by wearing suitable protective clothing, gloves, eye protection, etc.

Contact with hot oil may cause the skin to be scalded or burned.

- Unscrew and remove the oil filter using Triumph service tool T3880313. Dispose of the old oil filter in an environmentally friendly way.
- Apply a thin smear of clean engine oil to the sealing ring of the new oil filter. Fit the oil filter and tighten to **10 Nm**.
- After the oil has completely drained out, fit a new sealing washer to the drain plug. Fit and tighten the drain plug to **25 Nm**.
- Fill the engine with a 10W/40 or 10W/50 semi or fully synthetic motorcycle engine oil that meets specification API SH (or higher) **and** JASO MA, such as Castrol Power 1 Racing 4T 10W-40 (fully synthetic).
- Start the engine and allow it to idle for a minimum of 30 seconds.

Caution

Raising the engine speed above idle before the oil reaches all parts of the engine can cause engine damage or seizure.

Only raise engine speed after running the engine for 30 seconds to allow the oil to circulate fully.

Caution

If the engine oil pressure is too low, the low oil pressure warning light will illuminate. If this light stays on when the engine is running, stop the engine immediately and investigate the cause.

Running the engine with low oil pressure will cause engine damage.

- Make sure that the low oil pressure warning light remains off and the oil pressure message is not visible in the instrument display screen.
- Stop the engine and recheck the oil level. Adjust if necessary.

Disposal of Used Engine Oil and Oil Filters

To protect the environment, do not pour oil on the ground, down sewers or drains, or into watercourses. Do not place used oil filters in with general waste. If in doubt, contact your local authority.

Oil Specification and Grade

Triumph's high performance fuel injected engines are designed to use 10W/40 or 10W/50 semi or fully synthetic motorcycle engine oil that meets specification API SH (or higher) and JASO MA, such as Castrol Power 1 Racing 4T 10W-40 (fully synthetic) engine oil, sold as Castrol Power RS Racing 4T 10W-40 (fully synthetic) in some countries.

Refer to the chart below for the correct oil viscosity (10W/40 or 10W/50) to be used in your riding area.

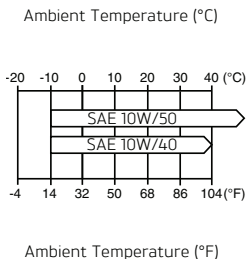

Oil Viscosity Temperature Range

Do not add any chemical additives to the engine oil. The engine oil also lubricates the clutch and any additives could cause the clutch to slip.

Do not use mineral, vegetable, non-detergent oil, castor based oils or any oil not conforming to the required specification. The use of these oils may cause instant, severe engine damage.

Make sure that no foreign matter enters the crankcase during an engine oil change or top up.

Cooling System



To ensure efficient engine cooling, check the coolant level each day before riding the motorcycle, and top up the coolant if the level is low.

Note:

- A year round, Hybrid Organic Acid Technology (known as Hybrid OAT or HOAT) coolant is installed in the cooling system when the motorcycle leaves the factory. It is coloured green, contains a 50% solution of ethylene glycol based antifreeze, and has a freezing point of -35°C (-31°F).

Corrosion Inhibitors

! Warning

HD4X Hybrid OAT coolant contains corrosion inhibitors and antifreeze suitable for aluminium engines and radiators. Always use the coolant in accordance with the instructions of the manufacturer.

Coolant that contains anti-freeze and corrosion inhibitors contains toxic chemicals that are harmful to the human body. Never swallow antifreeze or any of the motorcycle coolant.

Maintenance

Note:

- **HD4X Hybrid OAT coolant, as supplied by Triumph, is premixed and does not need to be diluted prior to filling or topping up the cooling system.**

To protect the cooling system from corrosion, the use of corrosion inhibitor chemicals in the coolant is essential.

If coolant containing a corrosion inhibitor is not used, the cooling system will accumulate rust and scale in the water jacket and radiator. This will block the coolant passages, and considerably reduce the efficiency of the cooling system.

Coolant Level Inspection

Note:

- **The coolant level should be checked when the engine is cold (at room or ambient temperature).**

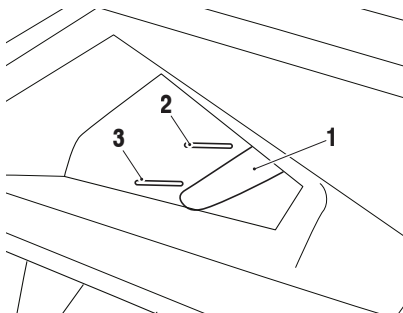

1. Expansion tank
2. MAX mark
3. MIN mark

To inspect the coolant level:

- Position the motorcycle on level ground and in an upright position (not on the stand). The expansion tank can be viewed from the right hand side of the motorcycle, below and towards the front of the fuel tank.
- Check the coolant level in the expansion tank.
- The coolant level must be between the MAX and MIN marks. If the coolant is below the minimum level, the coolant level must be adjusted.

Coolant Level Adjustment

Warning

Do not remove the expansion tank or radiator pressure cap when the engine is hot.

When the engine is hot, the coolant inside the radiator will be hot and also under pressure.

Contact with this hot, pressurised coolant will cause scalds and skin damage.

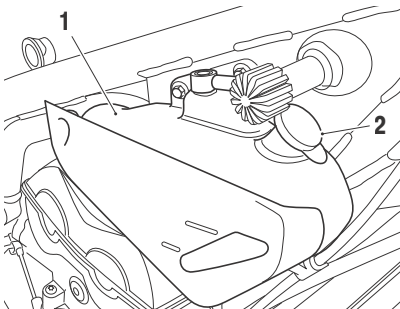

1. Expansion tank (fuel tank shown removed for clarity)
2. Expansion tank cap

To adjust the coolant level:

- Allow the engine to cool.
- The expansion tank cap can be removed from the right hand side of the motorcycle, between the front of the fuel tank and the frame.
- Remove the cap from the expansion tank and add coolant mixture through the filler opening until the level reaches the MAX mark.
- Refit the cap.

Note:

- If the coolant level is being checked because the coolant has overheated, also check the level in the radiator and top up if necessary.
- In an emergency, distilled water can be added to the cooling system. However, the coolant must then be drained and replenished with HD4X Hybrid OAT coolant as soon as possible.

Caution

If hard water is used in the cooling system, it will cause scale accumulation in the engine and radiator, and considerably reduce the efficiency of the cooling system.

Reduced cooling system efficiency may cause the engine to overheat and suffer severe damage.

Coolant Change

It is recommended that the coolant is changed by an authorised Triumph dealer in accordance with scheduled maintenance requirements.

Radiator and Hoses

Warning

The fan operates automatically when the engine is running. Always keep hands and clothing away from the fan as contact with the rotating fan can cause injury.

Caution

Using high pressure water sprays, such as from a car wash facility or household pressure washer, can damage the radiator fins, cause leaks and impair the radiator's efficiency.

Do not obstruct or deflect airflow through the radiator by installing unauthorised accessories, either in front of the radiator or behind the cooling fan. Interference with the radiator airflow can cause overheating, potentially resulting in engine damage.

Check the radiator hoses for cracks or deterioration, and hose clips for tightness in accordance with scheduled maintenance requirements. Have your authorised Triumph dealer replace any defective items.

Check the radiator grille and fins for obstructions by insects, leaves or mud. Clean off any obstructions with a stream of low pressure water.

Throttle Control

Warning

Always be alert for changes in the 'feel' of the throttle control and have the throttle system checked by an authorised Triumph dealer if any changes are detected. Changes can be due to wear in the mechanism, which could lead to a sticking throttle control.

A sticking or stuck throttle control will lead to loss of motorcycle control and an accident.

Clutch

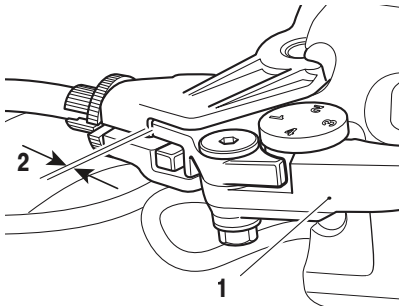

1. Clutch lever
2. 2 - 3 mm

The motorcycle is equipped with a cable-operated clutch.

If the clutch lever has excessive free play, the clutch may not disengage fully. This will cause difficulty in changing gear and selecting neutral. This may cause the engine to stall and make the motorcycle difficult to control.

Conversely, if the clutch lever has insufficient free play the clutch may not engage fully, causing the clutch to slip, which will reduce performance and cause premature clutch wear.

Clutch lever free play must be checked in accordance with scheduled maintenance requirements.

Clutch Inspection

Check that there is 2 - 3 mm clutch lever free play at the lever.

If there is an incorrect amount of free play, adjustments must be made.

Clutch Adjustment

To adjust the clutch:

- Turn the adjuster sleeve until the correct amount of clutch lever free play is achieved.
- Check that there is 2 - 3 mm clutch lever free play at the lever.
- If there is an incorrect amount of free play, adjustments must be made.

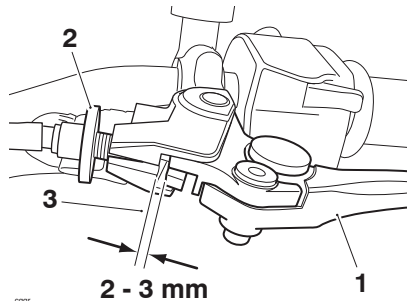

1. Clutch lever
2. Adjuster sleeve (locknut fully released)
3. Correct clearance 2-3 mm

- If correct adjustment cannot be made using the lever adjuster, use the cable adjuster at the lower end of the cable.
- Loosen the adjuster locknut.
- Turn the outer cable adjuster to give 2 - 3 mm of free play at the clutch lever.

Maintenance

- Tighten the locknut to **3.5 Nm**.

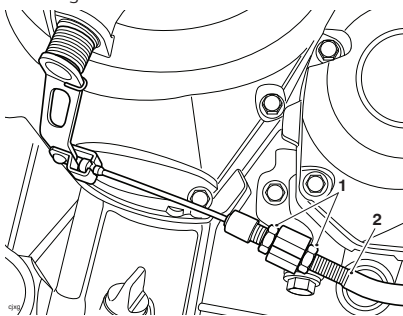

1. Adjuster nuts
2. Clutch outer cable

Drive Chain



Warning

A loose or worn chain, or a chain that breaks or jumps off the sprockets could catch on the engine sprocket or lock the rear wheel.

A chain that snags on the engine sprocket will injure the rider and lead to loss of motorcycle control and an accident.

Similarly, locking the rear wheel will lead to loss of motorcycle control and an accident.

For safety and to prevent excessive wear the drive chain must be checked, adjusted and lubricated in accordance with the scheduled maintenance requirements. Checking, adjustment and lubrication must be carried out more frequently for extreme conditions such as high speed riding, salty or heavily gritted roads.

If the chain is badly worn or incorrectly adjusted (either too loose or too tight) the chain could jump off the sprockets or break. Therefore, always replace worn or damaged chains using genuine Triumph parts supplied by an authorised Triumph dealer.

Drive Chain Lubrication

Lubrication is necessary every 200 miles (300 km) and also after riding in wet weather, on wet roads, or any time that the chain appears dry.

To lubricate the drive chain:

- Use the special drive chain lubricant as recommended in the Specifications section.
- Apply lubricant to the sides of the rollers then allow the motorcycle to stand unused for at least eight hours (overnight is ideal). This will allow the oil to penetrate to the drive chain O-rings etc.
- Before riding, wipe off any excess oil.
- If the drive chain is especially dirty, clean first and then apply oil as mentioned above.

⚠ Caution

Do not use a pressure washer to clean the drive chain as this may cause damage to the drive chain components.

Drive Chain Free Movement Inspection

⚠ Warning

Before starting work, make sure that the motorcycle is stabilised and adequately supported.

This will help prevent injury personal injury and/or damage to the motorcycle.

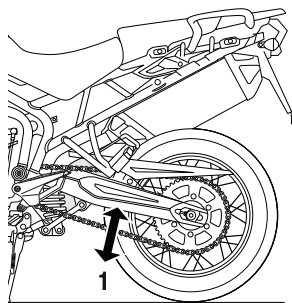

1. Maximum movement position

To inspect the drive chain free movement:

- Place the motorcycle on a level surface and hold it in an upright position with no weight on it.
- Rotate the rear wheel by pushing the motorcycle to find the position where the drive chain is tightest, and measure the vertical movement of the drive chain midway between the sprockets.

Maintenance

Drive Chain Free Movement Adjustment

The vertical movement of the drive chain must be in the range 20 - 30 mm.

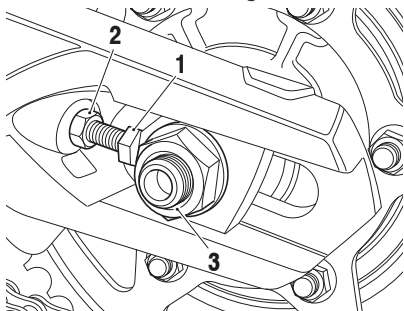

1. Adjuster bolt
2. Adjuster bolt lock nut
3. Rear wheel spindle nut

To adjust the drive chain free movement:

- Loosen the wheel spindle nut.
- Loosen the lock nuts on both the left hand and right hand drive chain adjuster bolts.
- Moving both adjusters by an equal amount, turn the adjuster bolts clockwise to increase drive chain free movement and anticlockwise to reduce drive chain free movement.
- When the correct amount of drive chain free movement has been set, push the wheel into firm contact with the adjusters.
- Tighten both adjuster lock nuts to **20 Nm** and the rear wheel spindle nut to **110 Nm**.
- Repeat the drive chain adjustment check. Readjust if necessary.

! Warning

Operation of the motorcycle with insecure adjuster lock nuts or a loose wheel spindle may result in impaired stability and handling of the motorcycle.

This impaired stability and handling may lead to loss of control or an accident.

- Check the rear brake effectiveness. Rectify if necessary.

! Warning

It is dangerous to operate the motorcycle with defective brakes; you must have your authorised Triumph dealer take remedial action before you attempt to ride the motorcycle again.

Failure to take remedial action may reduce braking efficiency leading to loss of motorcycle control or an accident.

Drive Chain and Sprocket Wear Inspection

Warning

Never neglect drive chain maintenance and always have drive chains installed by an authorised Triumph dealer.

Use a genuine Triumph supplied drive chain as specified in the Triumph Parts Catalogue.

The use of non-approved drive chains may result in a broken drive chain or may cause the drive chain to jump off the sprockets leading to loss of motorcycle control or an accident.

Caution

If the sprockets are found to be worn, always replace the sprockets and drive chain together.

Replacing worn sprockets without also replacing the drive chain will lead to premature wear of the new sprockets.

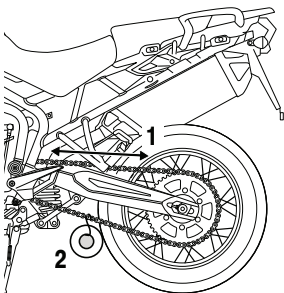

1. Measure across 20 links
2. Weight

To inspect the drive chain and sprocket wear:

- Remove the drive chain guard.
- Stretch the drive chain taut by hanging a 10 - 20 kg (20 - 40 lb) weight on the drive chain.
- Measure the length of 20 links on the straight part of the drive chain from pin centre of the 1st pin to the pin centre of the 21st pin. Since the drive chain may wear unevenly, take measurements in several places.
- If the length exceeds the maximum service limit of 319 mm, the drive chain must be replaced.
- Rotate the rear wheel and inspect the drive chain for damaged rollers, and loose pins and links.
- Also inspect the sprockets for unevenly or excessively worn or damaged teeth.

Worn Tooth (Engine Sprocket) Worn Tooth (Rear Sprocket)

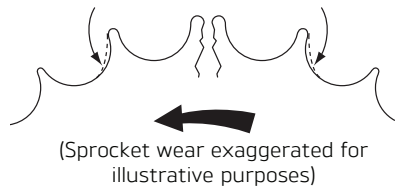

cool

- If there is any irregularity, have the drive chain and/or the sprockets replaced by an authorised Triumph dealer.
- Refit the drive chain guard, tightening the fixings to **9 Nm**.

Maintenance

Brakes

Brake Wear Inspection

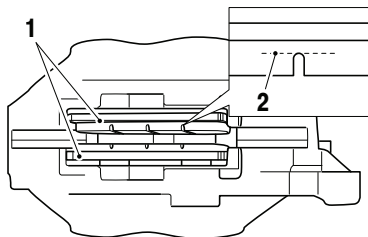

cbmz

1. Brake pads
2. Minimum thickness line

Brake pads must be inspected in accordance with scheduled requirements and replaced if worn to, or beyond the minimum service thickness.

If the lining thickness of any brake pad (front or rear brakes) is less than 1.5 mm (0.06 in), that is, if the brake pad has worn down to the bottom of the grooves, replace all the brake pads on the wheel.

Breaking-in New Brake Pads and Discs

Warning

Brake pads must always be replaced as a wheel set. At the front, where two calipers are fitted on the same wheel, replace all the brake pads in both calipers.

Replacing individual pads will reduce braking efficiency and may cause an accident.

After replacement brake pads have been fitted, ride with extreme caution until the new pads have 'broken in'.

New brake discs and pads require a period of careful breaking-in that will optimise the performance and longevity of the discs and pads. The recommended distance for breaking-in new pads and discs is 200 miles (300 km).

During this period, avoid extreme braking, ride with caution and allow for greater braking distances.

Brake Pad Wear Compensation

Warning

If the brake lever or pedal feels soft when it is applied, or if the lever/pedal travel becomes excessive, there may be air in the brake pipes and hoses or the brakes may be defective.

It is dangerous to operate the motorcycle under such conditions and your authorised Triumph dealer must rectify the fault before riding.

Riding with defective brakes may lead to loss of motorcycle control and an accident.

Disc and brake pad wear is automatically compensated for and has no effect on the brake lever or pedal action. There are no parts that require adjustment on the front and rear brakes.

Disc Brake Fluid

Warning

Brake fluid is hygroscopic which means it will absorb moisture from the air.

Any absorbed moisture will greatly reduce the boiling point of the brake fluid causing a reduction in braking efficiency.

Because of this, always replace brake fluid in accordance with scheduled maintenance requirements.

Always use new brake fluid from a sealed container and never use fluid from an unsealed container or from one which has been previously opened.

Do not mix different brands or grades of brake fluid.

Check for fluid leakage around brake fittings, seals and joints and also check the brake hoses for splits, deterioration and damage.

Always rectify any faults before riding.

Failure to observe and act upon any of these items may cause a dangerous riding condition leading to loss of control and an accident.

Warning

If the ABS is not functioning, the brake system will continue to function as a non-ABS equipped brake system. In this situation, braking too hard will cause the wheels to lock resulting in loss of control and an accident.

Reduce speed and do not continue to ride for longer than is necessary with the indicator light illuminated. Contact an authorised Triumph dealer as soon as possible to have the fault checked and rectified.

Inspect the level of brake fluid in both reservoirs and change the brake fluid in accordance with scheduled maintenance requirements. Use only DOT 4 fluid as recommended in the Specification section. The brake fluid must also be changed if it becomes, or is suspected of having become contaminated with moisture or any other contaminants.

Note:

- **A special tool is required to bleed the ABS braking system. Contact your authorised Triumph dealer when the brake fluid needs renewing or the hydraulic system requires maintenance.**

Brake Fluid Level Inspection and Adjustment

Warning

If there has been an appreciable drop in the level of the fluid in either fluid reservoir, consult your authorised Triumph dealer for advice before riding.

Riding with depleted brake fluid levels, or with a brake fluid leak is dangerous and will cause reduced brake performance potentially leading to loss of motorcycle control and an accident.

Front Brake Fluid Level Inspection and Adjustment

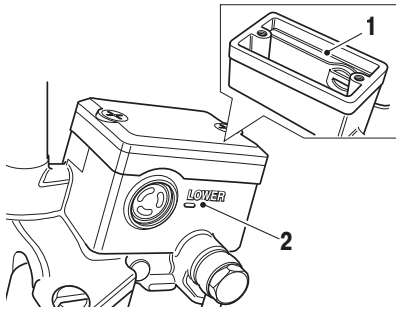

1. Front brake fluid reservoir, upper level line
2. Lower level line

The brake fluid level in the reservoirs must be kept between the upper and lower level lines (reservoir held horizontal).

To inspect the fluid level:

- Check the level of fluid visible in the window at the front of the reservoir body.

To adjust the fluid level:

- Release the cap screws and remove the cover and the diaphragm seal.
- Fill the reservoir to the upper level line using new DOT 4 fluid from a sealed container.
- Refit the cover, making sure that the diaphragm seal is correctly positioned between the cap and reservoir body.
- Tighten the cap retaining screws to **1 Nm**.

Rear Brake Fluid Inspection and Adjustment

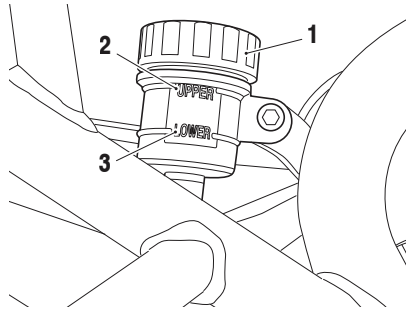

1. Rear brake fluid reservoir
2. Upper level line
3. Lower level line

The reservoir is visible from the right hand side for the motorcycle, forward of the exhaust intermediate pipe, below the rider's seat.

To inspect the fluid level:

- Check the level of fluid visible in the reservoir. The fluid level must be kept between the upper and lower level lines (reservoir held horizontal).

To adjust the fluid level:

- Remove the reservoir cap and the diaphragm seal.
- Fill the reservoir to the upper level line using new DOT 4 fluid from a sealed container.
- Refit the reservoir cap making sure that the diaphragm seal is correctly positioned between the cap and reservoir body.

Maintenance

Rear Brake Fluid Inspection and Adjustment - Accessory Rear Brake Reservoir (if fitted)

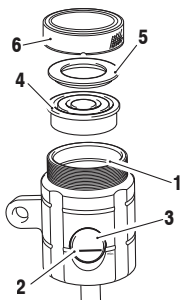

1. Upper level line
2. Lower level line
3. Window
4. Diaphragm seal
5. Diaphragm support ring
6. Reservoir cap

The fluid level must be kept between the upper and lower level lines (reservoir held horizontal).

To inspect the fluid level:

- Check the level of fluid visible in the window at the front of the reservoir body.

To adjust the fluid level:

- Remove the reservoir cap, support ring and the diaphragm seal.
- Fill the reservoir to the upper level line using new DOT 4 fluid from a sealed container.
- Fit the diaphragm and diaphragm support ring into the fluid reservoir.
- Fit the reservoir cap and carefully screw it down, making sure it is fully tightened.

Brake Light Switches

Warning

Riding the motorcycle with defective brake lights is illegal and dangerous.

An accident causing injury to the rider and other road users may result from use of a motorcycle with defective brake lights.

The brake light is activated independently by either the front or rear brake. If, with the ignition in the ON position, the brake light does not work when the front brake lever is pulled or the rear brake pedal is pressed, have your authorised Triumph dealer investigate and rectify the fault.

Steering Inspection

Warning

To prevent risk of injury from the motorcycle falling during the inspection, make sure that the motorcycle is stabilised and secured on a suitable support.

Do not exert extreme force against each wheel or rock each wheel vigorously as this may cause the motorcycle to become unstable and cause injury by falling from its support.

Make sure that the position of the support block will not cause damage to the motorcycle.

Warning

Riding the motorcycle with incorrectly adjusted or defective steering (headstock) bearings is dangerous and may cause loss of motorcycle control and an accident.

Note:

- **Always inspect the wheel bearings at the same time as the steering bearings.**

Inspecting the Steering (Headstock) Bearings for Free Play

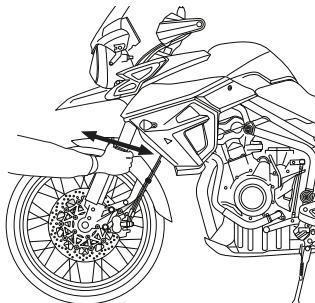

Inspecting the Steering for Free Play

To inspect the steering:

- Position the motorcycle on level ground, in an upright position.
- Raise the front wheel above the ground and support the motorcycle.
- Standing at the front of the motorcycle, hold the lower end of the front forks and try to move them forward and backward.
- If any free play can be detected in the steering (headstock) bearings, ask your authorised Triumph dealer to inspect and rectify any faults before riding.
- Remove the support and place the motorcycle on the side stand.

Note:

- **Lubricate and inspect the condition of the steering (headstock) bearings in accordance with scheduled maintenance requirements.**

Maintenance

Wheel Bearings Inspection

Warning

Operation with worn or damaged front or rear wheel bearings is dangerous and may cause impaired handling and instability leading to an accident.

If in doubt, have the motorcycle inspected by an authorised Triumph dealer before riding.

To inspect the wheel bearings:

- If the wheel bearings in the front or rear wheel allow play in the wheel hub, are noisy, or if the wheel does not turn smoothly, have your authorised Triumph dealer inspect the wheel bearings.
- The wheel bearings must be inspected at the intervals specified in the scheduled maintenance chart.
- Position the motorcycle on level ground, in an upright position.
- Raise the front wheel above the ground and support the motorcycle.
- Standing at the side of the motorcycle, gently rock the top of the front wheel from side to side.
- If any free play can be detected, ask your authorised Triumph dealer to inspect and rectify any faults before riding.
- Reposition the lifting device and repeat the procedure for the rear wheel.
- Remove the support and place the motorcycle on the side stand.

Front Suspension

Warning

Riding the motorcycle with defective or damaged suspension is dangerous and may lead to loss of control and an accident.

Warning

Never attempt to dismantle any part of the suspension units, as all units contain pressurised oil.

Skin and eye damage can result from contact with the pressurised oil.

Front Fork Inspection

Examine each fork for any sign of damage, scratching of the slider surface, or for oil leaks.

If any damage or leakage is found, consult an authorised Triumph dealer.

To check that the forks operate smoothly:

- Position the motorcycle on level ground.
- While holding the handlebars and applying the front brake, pump the forks up and down several times.
- If roughness or excessive stiffness is detected, consult your authorised Triumph dealer.

Front Suspension Setting Charts



Make sure that the correct balance between front and rear suspension is maintained.

Suspension imbalance could significantly change handling characteristics leading to loss of control and an accident.

Refer to the front and rear suspension setting charts for further information or consult your Triumph dealer.

The motorcycle is delivered from the factory with the front suspension set at the Solo (normal) riding setting, as shown in the relevant front suspension setting chart. The Solo suspension settings provide a comfortable ride and good handling characteristics for general, solo riding.

The suspension settings charts show suggested settings for the front suspension and are only a guide. Setting requirements may vary for rider weight and personal preferences.

Tiger 800 XRT

Loading	Front Suspension	
	Compression Damping ¹	Rebound Damping ¹
Solo (Normal) Riding	6	5
Solo (Comfort) Riding	12	12
Solo (Sport) Riding	4	4
Solo (with any loaded luggage items where applicable)	6	5
Rider and Passenger	6	5
Rider and Passenger (with any loaded luggage items where applicable)	6	5

¹ Number of clicks anticlockwise from the fully clockwise (closed) position – noting that the first stop (click) is counted as 1.

Maintenance

Tiger 800 XCX and Tiger 800 XCA

Loading	Front Suspension	
	Compression Damping ¹	Rebound Damping ¹
Solo (Normal) Riding	12	12
Solo (Comfort) Riding	19	19
Solo (Sport) Riding	4	4
Solo (with any loaded luggage items where applicable)	10	10
Rider and Passenger	7	7
Rider and Passenger (with any loaded luggage items where applicable)	6	6

¹ Number of clicks anticlockwise from the fully clockwise (closed) position – noting that the first stop (click) is counted as 1.

Front Suspension Adjustment

Tiger 800 XR, Tiger 800 XRX and Tiger 800 XRX - LRH

The motorcycles have no front suspension adjustment.

Tiger 800 XCA, Tiger 800 XCX and Tiger 800 XRT

The motorcycles are delivered from the factory with the front suspension set at the Solo (normal) riding setting, as detailed in the relevant suspension charts. The front suspension is adjustable and is described in the following sections.

Compression Damping Adjustment - Tiger 800 XCA and Tiger 800 XCX

The compression damping adjuster is located at the top of the left hand fork.

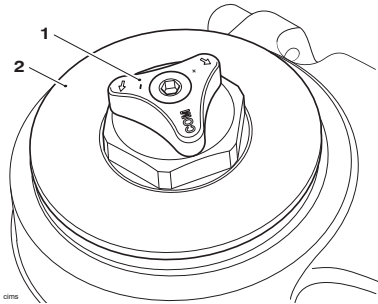

1. Compression damping adjuster (white)
2. Fork top cap

To adjust the front compression damping setting:

- Rotate the compression damping adjuster clockwise to increase, or anticlockwise to decrease.
- Always count the number of clicks back from the fully clockwise (closed) position.

Compression Damping Adjustment - Tiger 800 XRT

The compression damping adjuster is located at the top of the right hand fork.

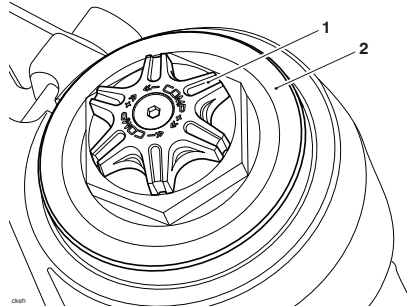

1. Compression damping adjuster
2. Fork top cap

To adjust the front compression damping setting:

- Rotate the compression damping adjuster clockwise to increase, or anticlockwise to decrease.
- Always count the number of clicks back from the fully clockwise (closed) position.

Maintenance

Rebound Damping Adjustment - Tiger 800 XCA and Tiger 800 XCX

The rebound damping adjuster is located at the top of the right hand fork.

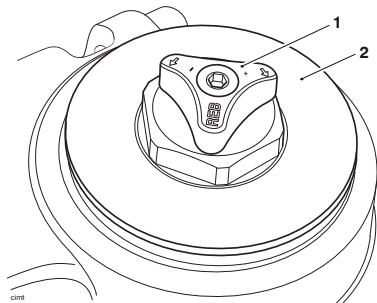

1. Rebound damping adjuster (red)
2. Fork top cap

To adjust the front rebound damping setting:

- Rotate the rebound damping adjuster clockwise to increase, or anticlockwise to decrease.
- Always count the number of clicks back from the fully clockwise (closed) position.

Rebound Damping Adjustment - Tiger 800 XRT

The rebound damping adjuster is located at the top of the left hand fork.

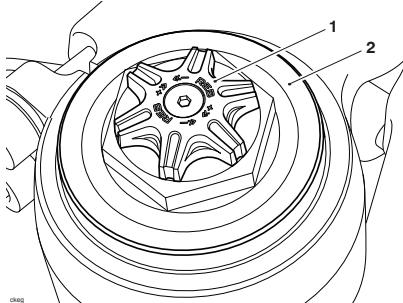

1. Rebound damping adjuster
2. Fork top cap

To adjust the front rebound damping setting:

- Rotate the rebound damping adjuster clockwise to increase, or anticlockwise to decrease.
- Always count the number of clicks back from the fully clockwise (closed) position.

Rear Suspension

Warning

Riding the motorcycle with defective or damaged suspension is dangerous and may lead to loss of control and an accident.

Warning

Never attempt to dismantle any part of the suspension units, as all units contain pressurised oil.

Skin and eye damage can result from contact with the pressurised oil.

Rear Suspension Adjustment

The motorcycles are delivered from the factory with the rear suspension set at the Solo (normal) riding setting, as detailed in the relevant suspension charts.

Spring Preload Adjustment – Tiger 800 XR, Tiger 800 XRT, Tiger 800 XRX and Tiger 800 XRX - LRH

The spring preload adjuster is situated on the right hand side of the motorcycle, at the top of the rear suspension unit.

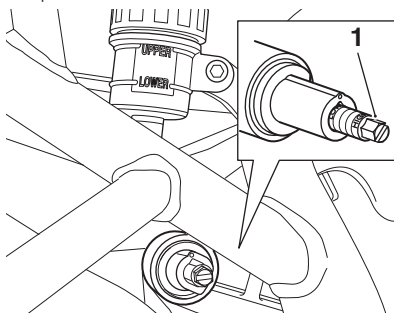

1. Spring preload adjuster

To adjust the spring preload setting:

- Rotate the slotted spring preload adjuster clockwise to increase, or anticlockwise to decrease.
- The setting is measured as the number of clicks anticlockwise from the fully clockwise (closed) position.

Maintenance

Spring Preload Adjustment – Tiger 800 XCA and Tiger 800 XCX

The spring preload adjuster is situated on the right hand side of the motorcycle, at the top of the rear suspension unit.

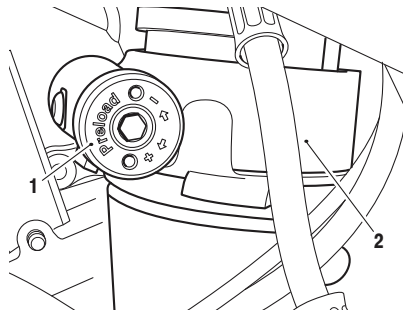

1. Spring preload adjuster
2. Rear suspension unit

To adjust the spring preload setting:

- Rotate the 5 mm hexagon adjuster clockwise to increase, or anticlockwise to decrease.
- The setting is measured as the number of adjuster turns anticlockwise from the fully clockwise (closed) position.

Rebound Damping Adjustment – Tiger 800 XCA, Tiger 800 XCX and Tiger 800 XRT

The rebound damping adjuster is located at the bottom of the rear suspension unit and is accessible from either side of the motorcycle.

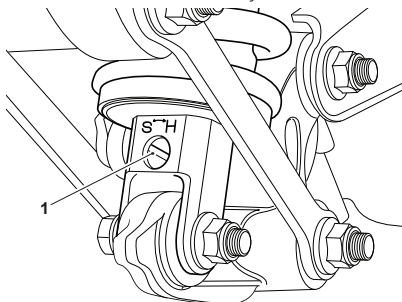

1. Rebound damping adjuster

To adjust the rebound damping setting:

- Rotate the slotted adjuster clockwise to increase (H = harder suspension) and anticlockwise to decrease (S = softer suspension).
- The setting is measured as the number of adjuster turns anticlockwise from the fully clockwise (closed) position.

Rear Suspension Setting Charts



Make sure that the correct balance between front and rear suspension is maintained.

Suspension imbalance could significantly change handling characteristics leading to loss of control and an accident.

Refer to the front and rear suspension setting charts for further information or consult your Triumph dealer.

Rear Suspension Setting Chart – Tiger 800 XR, Tiger 800 XRX and Tiger 800 XRX - LRH

Loading	Spring Preload ¹
Solo (Normal) Riding	30
Rider and Luggage	0
Rider and Passenger, or Rider, Passenger and Luggage	0

¹ Number of clicks anticlockwise from the fully clockwise (closed) position – noting that the first stop (click) is counted as 1.

The motorcycle is delivered from the factory with the rear suspension set at the Solo (normal) riding settings, as shown in the relevant suspension chart. The Solo suspension settings provide a comfortable ride and good handling characteristics for general, solo riding.

The suspension settings charts show suggested settings for the rear suspension and are only a guide. Setting requirements may vary for rider weight and personal preferences.

An increase in spring preload requires firmer damping. A reduction in spring preload requires softer damping. The damping must be adjusted to the road conditions and the spring preload.

Maintenance

Rear Suspension Setting Chart – Tiger 800 XRT

Loading	Spring Preload ¹	Rebound Damping ²
Solo (Normal) Riding	31	1.5
Solo (Comfort) Riding	31	2.5
Solo (Sport) Riding	31	1
Solo (with any loaded luggage items where applicable)	14	1
Rider and Passenger	1	0.75
Rider and Passenger (with any loaded luggage items where applicable)	1	0.5

¹Number of adjuster clicks anticlockwise from the fully clockwise (closed) position - noting that the first stop (click) is counted as 1.

²Number of adjuster turns anticlockwise from the fully clockwise (closed) position.

Rear Suspension Setting Chart – Tiger 800 XCA and Tiger 800 XCX

Loading	Spring Preload ¹	Rebound Damping ¹
Solo (Normal) Riding	9	1.5
Solo (Comfort) Riding	9	3.0
Solo (Sport) Riding	9	0.5
Solo (with any loaded luggage items where applicable)	4.5	1
Rider and Passenger	Fully Clockwise	0.5
Rider and Passenger (with any loaded luggage items where applicable)	Fully Clockwise	0.25

¹Number of adjuster turns anticlockwise from the fully clockwise (closed) position.

Bank Angle Indicators



Warning

Use of a motorcycle with bank angle indicators worn beyond the maximum limit (as described below) will allow the motorcycle to be banked to an unsafe angle.

Banking to an unsafe angle may cause instability, loss of motorcycle control and an accident.

Bank angle indicators are located on the riders footrests.

Regularly check the bank angle indicators for wear.

The bank angle indicators have reached the maximum wear limit and should be replaced when they have worn down to a length of:

- 20 mm - All models except Tiger 800 XCA
- 25 mm - Tiger 800 XCA only.

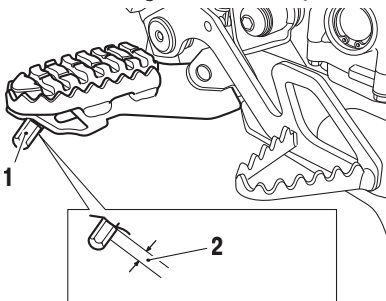

1. Bank angle indicator
2. Wear limit measurement

Tyres



cb0a

Tiger XC Models

The Tiger 800 XC model variants are fitted with spoked wheels which require a tyre suitable for use with an inner tube.



Warning

Failure to use an inner tube in a spoked wheel will cause deflation of the tyre resulting in loss of motorcycle control and an accident.

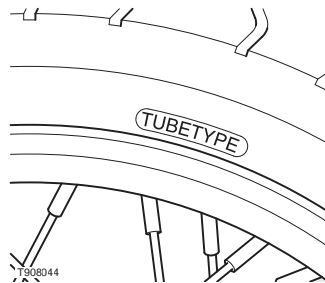

Typical Tyre Marking

Tiger XR Models

The Tiger 800 XR model variants are equipped with tubeless tyres, valves and wheel rims. Use only tyres marked TUBELESS and tubeless valves on rims marked SUITABLE FOR TUBELESS TYRES.

Maintenance

! Warning

Do not install tube-type tyres on tubeless rims.

The bead will not seat and the tyres could slip on the rims, causing rapid tyre deflation that may result in a loss of vehicle control and an accident.

Never install an inner tube inside a tubeless tyre. This will cause friction inside the tyre and the resulting heat build-up may cause the tube to burst resulting in rapid tyre deflation, loss of motorcycle control and an accident.

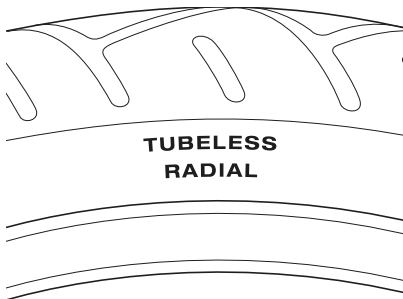

**TUBELESS
RADIAL**

Typical Tyre Marking - Tubeless Tyre

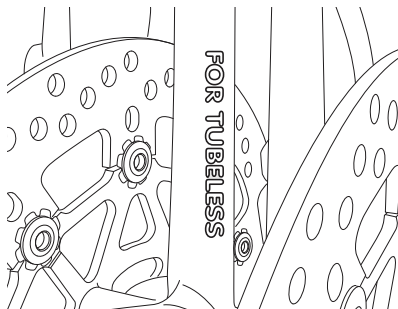

Wheel Marking - Tubeless Wheel

! Warning

Inner tubes must only be used on motorcycles fitted with spoked wheels and with tyres marked TUBE TYPE.

Some brands of approved tyre marked TUBELESS may be suitable for use with an inner tube. Where this is the case, the tyre wall will be marked with text permitting the fitment of an inner tube (see illustration below).

Use of an inner tube with a tyre marked TUBELESS, and NOT marked as suitable for use with an inner tube, or use of an inner tube on an alloy wheel marked SUITABLE FOR TUBELESS TYRES will cause deflation of the tyre resulting in loss of motorcycle control and an accident.

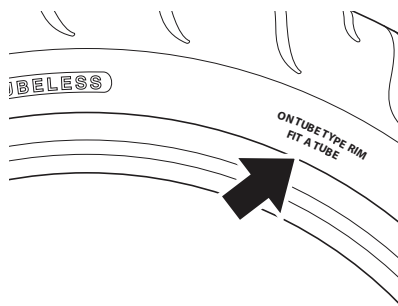

**Typical Tyre Marking - Tubeless Tyre
Suitable For Use With An Inner Tube**

Tyre Inflation Pressures



Incorrect tyre inflation will cause abnormal tread wear and instability problems that may lead to loss of control and an accident.

Underinflation may result in the tyre slipping on, or coming off the rim. Overinflation will cause instability and accelerated tread wear.

Both conditions are dangerous as they may cause loss of control leading to an accident.

Correct inflation pressure will provide maximum stability, rider comfort and tyre life. Always check tyre pressures before riding when the tyres are cold. Check tyre pressures daily and adjust if necessary. See the Specification section for details of the correct inflation pressures.

Tyre Pressure Monitoring System (if fitted)

The tyre pressures shown on your instruments indicate the actual tyre pressure at the time of selecting the display. This may differ from the inflation pressure set when the tyres are cold because tyres become warmer during riding, causing the air in the tyre to expand and increase the inflation pressure. The cold inflation pressures specified by Triumph take account of this.

Only adjust tyre pressures when the tyres are cold using an accurate pressure gauge. Do not use the tyre pressure display on the instruments.

Tyre Wear

As the tyre tread wears down, the tyre becomes more susceptible to punctures and failure. It is estimated that 90% of all tyre problems occur during the last 10% of tread life (90% worn). It is recommended that tyres are changed before they are worn to their minimum tread depth.

Minimum Recommended Tread Depth

Warning

Operation with excessively worn tyres is hazardous and will adversely affect traction, stability and handling which may lead to loss of control and an accident.

When tubeless tyres, used without a tube, become punctured, leakage is often very slow. Always inspect tyres very closely for punctures. Check the tyres for cuts, embedded nails or other sharp objects. Operation with punctured or damaged tyres will adversely affect motorcycle stability and handling which may lead to loss of control or an accident.

Check the rims for dents or deformation. Operation with damaged or defective wheels or tyres is dangerous and loss of motorcycle control or an accident could result.

Always consult your authorised Triumph dealer for tyre replacement, or for a safety inspection of the tyres.

In accordance with the periodic maintenance chart, measure the depth of the tread with a depth gauge, and replace any tyre that has worn to, or beyond the minimum allowable tread depth specified in the table below:

Under 80 mph (130 km/h)	2 mm (0.08 in)
Over 80 mph (130 km/h)	Front 2 mm (0.08 in) Rear 3 mm (0.12 in)

Tyre Replacement

All Triumph motorcycles are carefully and extensively tested in a range of riding conditions to ensure that the most effective tyre combinations are approved for use on each model. It is essential that approved tyres and inner tubes (if installed) fitted in approved combinations, are used when purchasing replacement items. The use of non-approved tyres and inner tubes, or approved tyres and inner tubes in non-approved combinations, may lead to motorcycle instability, loss of control and an accident.

A list of approved tyres and inner tubes specific to your motorcycle are available from your authorised Triumph dealer, or on the Internet at www.triumph.co.uk. Always have tyres and inner tubes fitted and balanced by your authorised Triumph dealer who has the necessary training and skills to ensure safe, effective fitment.

Different wheel speeds, caused by non-approved tyres, can affect the function of the ABS computer.

Warning

The ABS system operates by comparing the relative speed of the front and rear wheels. Use of non-recommended tyres can affect wheel speed and cause the ABS function not to operate, potentially leading to loss of control and an accident in conditions where the ABS would normally function.

Warning

If a tyre or inner tube sustains a puncture, the tyre and inner tube must be replaced. Failure to replace a punctured tyre and inner tube, or operation with a repaired tyre or inner tube can lead to instability, loss of motorcycle control or an accident.

Warning

Inner tubes must only be used on motorcycles fitted with spoked wheels and with tyres marked 'TUBE TYPE'.

Some brands of approved tyres marked 'TUBELESS' may be suitable for use with an inner tube. Where this is the case, the tyre wall will be marked with text permitting the fitment of an inner tube.

Use of an inner tube with a tyre marked 'TUBELESS', and NOT marked as suitable for use with an inner tube, or use of an inner tube on an alloy wheel marked 'SUITABLE FOR TUBELESS TYRES' will cause deflation of the tyre resulting in loss of motorcycle control and an accident.

Warning

Do not install tube-type tyres on tubeless rims. The bead will not seat and the tyres could slip on the rims, causing rapid tyre deflation that may result in a loss of vehicle control and an accident. Never install an inner tube inside a tubeless tyre without the appropriate marking. This will cause friction inside the tyre and the resulting heat build-up may cause the tube to burst resulting in rapid tyre deflation, loss of vehicle control and an accident.

Warning

If tyre damage is suspected, such as after striking the kerb, ask your authorised Triumph dealer to inspect the tyre both internally and externally. Remember, tyre damage may not always be visible from the outside. Operation of the motorcycle with damaged tyres could lead to loss of control and an accident.

Warning

Tyres and inner tubes that have been used on a rolling road dynamometer may become damaged. In some cases, the damage may not be visible on the external surface of the tyre.

Tyres and inner tubes must be replaced after such use as continued use of a damaged tyre or inner tube may lead to instability, loss of motorcycle control and an accident.

Warning

Accurate wheel balance is necessary for safe, stable handling of the motorcycle. Do not remove or change any wheel balance weights. Incorrect wheel balance may cause instability leading to loss of control and an accident.

When wheel balancing is required, such as after tyre or inner tube replacement, see your authorised Triumph dealer.

Only use self-adhesive weights. Clip on weights may damage the wheel, tyre or inner tube resulting in tyre deflation, loss of motorcycle control and an accident.

Warning

When replacement tyres or inner tubes are required, consult your authorised Triumph dealer who will arrange for the tyres and inner tubes to be selected, in a correct combination, from the approved list and fitted according to the tyre and inner tube manufacturer's instructions.

When tyres and inner tubes are replaced, allow time for the tyres and inner tubes to seat to the rim (approximately 24 hours). During this seating period, ride cautiously as an incorrectly seated tyre or inner tube could cause instability, loss of motorcycle control and an accident.

Initially, the new tyres and inner tubes will not produce the same handling characteristics as the worn tyres and inner tubes and the rider must allow adequate riding distance (approximately 100 miles (160 km)) to become accustomed to the new handling characteristics.

24 hours after fitting, the tyre pressures must be checked and adjusted, and the tyres and inner tubes examined for correct seating. Rectification must be carried out as necessary. The same checks and adjustments must also be carried out when 100 miles (160 km) have been travelled after fitting.

Use of a motorcycle with incorrectly seated tyres or inner tubes, incorrectly adjusted tyre pressures, or when not accustomed to its handling characteristics may lead to loss of motorcycle control and an accident.

Tyre Pressure Monitoring System (Only on models fitted with TPMS)

Caution

An adhesive label is fitted to the wheel rim to indicate the position of the tyre pressure sensor. Care must be taken when replacing the tyres to prevent any damage to the tyre pressure sensors. Always have your tyres fitted by your authorised Triumph dealer and inform them that tyre pressure sensors are fitted to the wheels.

Caution

Do not use anti puncture fluid or any other item likely to obstruct air flow to the TPMS sensor's orifices. Any blockage to the air pressure orifice of the TPMS sensor during operation will cause the sensor to become blocked, causing irreparable damage to the TPMS sensor assembly. Damage caused by the use of anti puncture fluid or incorrect maintenance is not considered a manufacturing defect and will not be covered under warranty. Always have your tyres fitted by your authorised Triumph dealer and inform them that tyre pressure sensors are fitted to the wheels.

Battery

Warning

Under some circumstances, the battery can give off explosive gases; keep sparks, flames and cigarettes away. Provide adequate ventilation when charging or using the battery in an enclosed space.

The battery contains sulphuric acid (battery acid). Contact with skin or eyes may cause severe burns. Wear protective clothing and a face shield.

If battery acid gets on your skin, flush with water immediately.

If battery acid gets in your eyes, flush with water for at least 15 minutes and SEEK MEDICAL ATTENTION IMMEDIATELY.

If battery acid is swallowed, drink large quantities of water and SEEK MEDICAL ATTENTION IMMEDIATELY.

KEEP BATTERY ACID OUT OF THE REACH OF CHILDREN.

Warning

The battery contains harmful materials. Always keep children away from the battery whether or not it is fitted in the motorcycle.

Do not attach jump leads to the battery, touch the battery cables together or reverse the polarity of the cables as any of these actions may cause a spark which would ignite battery gases causing a risk of personal injury.

Maintenance

Battery Removal



Make sure that the battery terminals do not touch the motorcycle frame as this may cause a short circuit or spark, which would ignite battery gases causing a risk of personal injury.

To remove the battery:

- Remove the rider's seat.

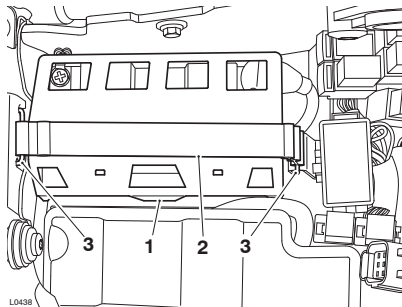

1. **Battery cover**
2. **Battery strap**
3. **Battery strap anchor points**

- Remove the battery strap.
- Remove the battery cover, noting the orientation of the cover and the leads.

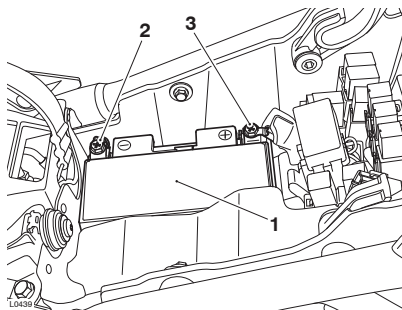

1. **Battery**
2. **Negative (-) terminal**
3. **Positive (+) terminal**

- Disconnect the battery leads, negative (black) lead first.
- Remove the battery out of the case.

Battery Disposal

Should the battery ever require replacement, the original battery must be handed to a recycling agent who will make sure that the dangerous substances from which the battery is manufactured do not pollute the environment.

Battery Maintenance

Warning

Battery acid is corrosive and poisonous and will cause damage to unprotected skin. Never swallow battery acid or allow it to come into contact with the skin. To prevent injury, always wear eye and skin protection when handling the battery.

Clean the battery using a clean, dry cloth. Make sure that the cable connections are clean.

The battery is a sealed type and does not require any maintenance other than checking the voltage and routine recharging when required, such as during storage (see the following paragraphs).

It is not possible to adjust the battery acid level in the battery; the sealing strip must not be removed.

Battery Discharge

Caution

The charge level in the battery must be maintained to maximise battery life.

Failure to maintain the battery charge level could cause serious internal damage to the battery.

Under normal conditions, the motorcycle charging system will keep the battery fully charged. However, if the motorcycle is unused, the battery will gradually discharge due to a normal process called self discharge; the clock, Engine Control Module (ECM) memory, high ambient temperatures, or the addition of electrical security systems or other electrical accessories will all increase this rate of battery discharge. Disconnecting the battery from the motorcycle during storage will reduce the rate of discharge.

Battery Discharge During Storage and Infrequent Use of the Motorcycle

During storage or infrequent use of the motorcycle, inspect the battery voltage weekly using a digital multimeter. Follow the manufacturer's instructions supplied with the meter.

Should the battery voltage fall below 12.7 Volts, the battery should be charged.

Allowing a battery to discharge or leaving it discharged for even a short period of time causes sulphation of the lead plates. Sulphation is a normal part of the chemical reaction inside the

Maintenance

battery, however over time the sulphate can crystallise on the plates making recovery difficult or impossible. This permanent damage is not covered by the motorcycle warranty, as it is not due to a manufacturing defect.

Keeping the battery fully charged reduces the likelihood of it freezing in cold conditions. Allowing a battery to freeze will cause serious internal damage to the battery.

Battery Charging

Warning

The battery gives off explosive gases; keep sparks, flames and cigarettes away. Provide adequate ventilation when charging or using the battery in an enclosed space.

The battery contains sulphuric acid (battery acid). Contact with skin or eyes may cause severe burns. Wear protective clothing and a face shield.

If battery acid gets on your skin, flush with water immediately.

If battery acid gets in your eyes, flush with water for at least 15 minutes and **SEEK MEDICAL ATTENTION IMMEDIATELY.**

If battery acid is swallowed, drink large quantities of water and **SEEK MEDICAL ATTENTION IMMEDIATELY.**

KEEP BATTERY ACID OUT OF THE REACH OF CHILDREN.

Caution

Do not use an automotive quick charger as it may overcharge and damage the battery.

For help with selecting a battery charger, checking the battery voltage or battery charging, contact your local authorised Triumph dealer.

Should the battery voltage fall below 12.7 Volts, the battery should be charged using a Triumph approved battery charger. Always remove the battery from the motorcycle and follow the instructions supplied with the battery charger.

For extended periods of storage (beyond two weeks) the battery should be removed from the motorcycle and kept charged using a Triumph approved maintenance charger.

Similarly, should the battery charge fall to a level where it will not start the motorcycle, remove the battery from the motorcycle before charging.

Battery Installation



Make sure that the battery terminals do not touch the motorcycle frame as this may cause a short circuit or spark, which would ignite battery gases causing a risk of personal injury.

To install the battery:

- Place the battery in the battery case.
- Reconnect the battery, positive (red) lead first and tighten the battery terminals to **4.5 Nm**.

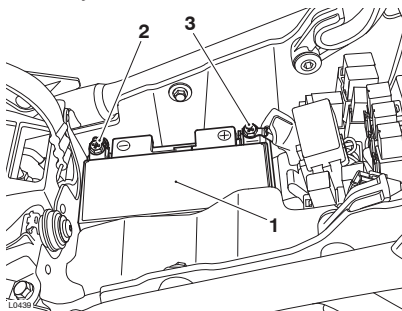

1. **Battery**
2. **Negative (-) terminal**
3. **Positive (+) terminal**

- Apply a light coat of grease to the terminals to prevent corrosion.

- Cover the positive terminal with the protective cap.

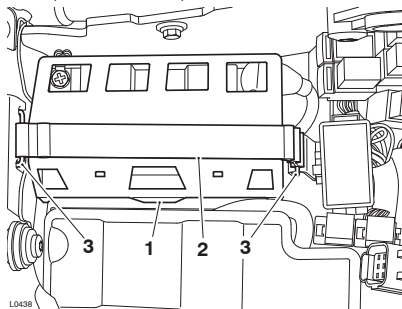

1. **Battery cover**
2. **Battery strap**
3. **Battery strap anchor points**

- Refit the battery cover. Make sure that the orientation of the leads and the battery cover are the same as before the removal process.
- Refit the battery strap.
- Refit the rider's seat.

Maintenance

Fuses

Warning

Always replace blown fuses with new ones of the correct rating (as specified on the fuse box cover) and never use a fuse of higher rating.

Use of an incorrect fuse could lead to an electrical problem, resulting in motorcycle damage, loss of motorcycle control and an accident.

Fuse Box Location

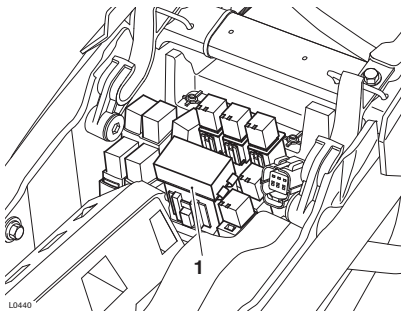

1. Fuse box

The fuse box is located beneath the rider's seat.

To allow access to the fuse boxes, the rider's seat must be removed (see page 104).

Note:

- The starter solenoid has an additional 30 Amp fuse, attached directly to the solenoid under the battery, beneath the rider's seat.

Fuse Identification

Warning

Always replace blown fuses with new ones of the correct rating (as specified on the fuse box cover) and never use a fuse of higher rating.

Use of an incorrect fuse could lead to an electrical problem, resulting in motorcycle damage, loss of motorcycle control and an accident.

Note:

- If the motorcycle is equipped with rider mode settings, then before disconnecting the battery or removing a fuse, note and record the rider mode settings. Once the fuse has been refitted or the battery reconnected then the rider mode settings should be reset as noted.

A blown fuse is indicated when all of the systems protected by that fuse become inoperative. When checking for a blown fuse, use the relevant tables to establish which fuse has blown.

The fuse identification numbers listed in the tables correspond with those printed on the fuse box covers, as shown below.

Tiger 800 XR

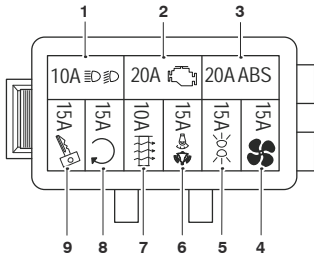

Position	Circuit Protected	Rating (Amps)
1	Dip and High Beam Headlights	10
2	Engine Management System	20
3	ABS	20
4	Cooling Fan	15
5	Rear Light, Position Light and Accessory Socket	15
6	Alarm, Instruments, Indicators and Starter Circuit	15
7	Heated Handlebar Grips, Fog Lights and USB Socket (if fitted)	10
8	Fuel Pump	15
9	Ignition Switch	15

Tiger 800 XRT and Tiger 800 XCA

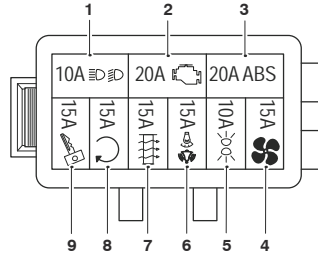

Position	Circuit Protected	Rating (Amps)
1	Headlights, Daytime Running Light (DRL) and Position Light	10
2	Engine Management System	20
3	ABS	20
4	Cooling Fan	15
5	Horn and Fog Lights	10
6	Alarm, Instruments, Indicators and Starter Circuit	15
7	Heated Handlebar Grips, Heated Seats and Accessory Socket	15
8	Fuel Pump	15
9	Ignition Switch, Rear Light and USB Socket	15

Maintenance

Tiger 800 XRX, Tiger 800 XRX - LRH and Tiger 800 XRC

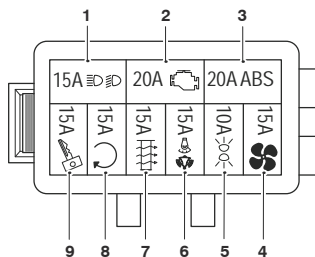

Position	Circuit Protected	Rating (Amps)
1	Dip and High Beam Headlights	15
2	Engine Management System	20
3	ABS	20
4	Cooling Fan	15
5	Horn and Fog Lights	10
6	Alarm, Instruments, Indicators and Starter Circuit	15
7	Heated Handlebar Grips and Accessory Socket	15
8	Fuel Pump	15
9	Ignition Switch, Rear Light, USB Socket, Daytime Running Light (DRL) and Position Light	15

Headlights



Warning

Adjust road speed to suit the visibility and weather conditions in which the motorcycle is being operated.

Make sure that the head light beam is adjusted to illuminate the road surface sufficiently far ahead without dazzling oncoming traffic. An incorrectly adjusted headlight may impair visibility causing an accident.

Warning

Never attempt to adjust a headlight beam when the motorcycle is in motion.

Any attempt to adjust a headlight beam when the motorcycle is in motion may result in loss of control and an accident.

⚠ Caution

Do not cover the headlight or lens with any item likely to obstruct air flow to, or prevent heat escaping from, the headlight lens.

Covering the headlight lens during operation with items of clothing, luggage, adhesive tape, devices intended to alter or adjust the headlight beam or non genuine headlight lens covers will cause the headlight lens to overheat and distort, causing irreparable damage to the headlight assembly.

Damage caused by overheating is not considered a manufacturing defect and will not be covered under warranty.

If the headlight must be covered during use - such as taping of the headlight lens required during closed-course conditions - the headlight must be disconnected.

Headlight Adjustment

LED Headlight Unit

The headlight can be adjusted by means of a vertical adjustment screw located on the rear of the headlight unit. There is no horizontal adjustment. In addition, the headlight is equipped with an easily accessible adjuster to allow the vertical adjustment to be corrected when the motorcycle is fully loaded.

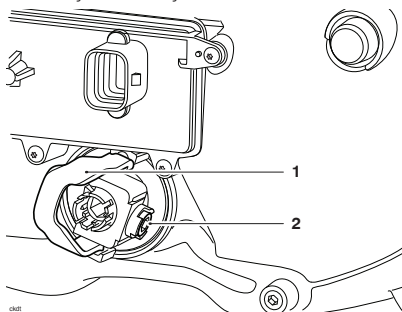

1. Headlight adjuster lever for loaded conditions
2. Vertical adjustment screw

To adjust the headlight:

- Switch the headlight dipped beam on.
- Turn the vertical adjustment screw on the headlight unit clockwise to raise the beam or anticlockwise to lower the beam.

Note:

- There is a small triangle marking on each side of the headlight unit which indicates the height of the light within the headlight unit for adjustment purposes.
- Switch the headlights off when the beam settings are satisfactory.

Maintenance

LED Headlight Unit Adjustment for Loaded Conditions

The headlight unit is equipped with an adjuster lever to allow the vertical adjustment to be corrected when the motorcycle is fully loaded.

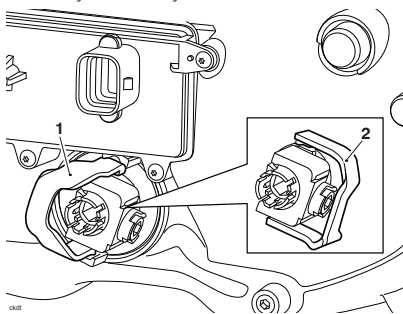

1. Headlight adjuster lever (loaded position)
2. Headlight adjuster lever (unloaded position)

For loaded conditions, move the headlight adjuster lever until it is in position (1). This will lower the headlight beams by approximately 2°.

For normal (unloaded) conditions, the headlight adjuster lever should be set in the horizontal position (2).

Bulb Headlight Unit

Each headlight can be adjusted by the vertical and horizontal adjustment screws located on the rear of each headlight. In addition, the headlight is equipped with an easily accessible adjuster to allow the vertical adjustment to be corrected when the motorcycle is fully loaded.

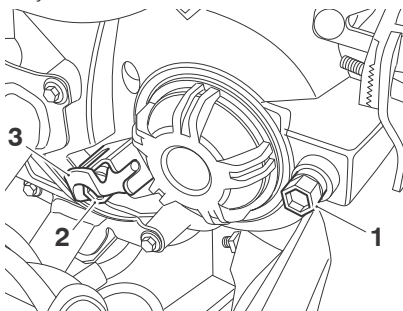

1. Horizontal (LEFT - RIGHT) adjustment screw
2. Vertical (UP - DOWN) adjustment screw
3. Headlight adjuster lever for loaded conditions

To adjust the headlight:

- Switch the headlight dipped beam on.
- Turn the vertical (UP - DOWN) adjustment screw on the headlight clockwise to raise the beam or anti-clockwise to lower the beam.
- Turn the horizontal (LEFT - RIGHT) adjustment screw clockwise to move the beam to the right or anti-clockwise to move the beam to the left.
- Switch the headlights off when the beam settings are satisfactory.

Bulb Headlight Unit Adjustment Lever for Loaded Conditions

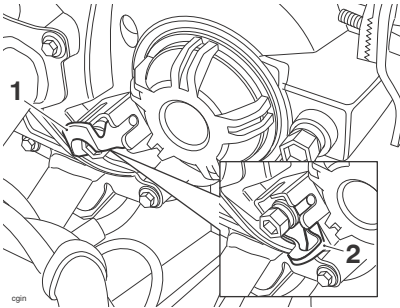

1. **Headlight adjuster lever (unloaded position)**
2. **Headlight adjuster lever (loaded position)**

For normal (unloaded) conditions the headlight adjuster lever should be set in the horizontal position (1).

For loaded conditions rotate the headlight adjuster downwards until it stops (2). This will lower the headlight beams by approximately 2°.

Bulb Replacement

Caution

The use of non-approved bulbs may result in damage to lenses and other lighting unit components.

In addition, the use of bulbs of incorrect wattage may cause the chassis ECM to cut power to affected lighting circuits.

Use genuine Triumph supplied bulbs as specified in the Triumph Parts Catalogue.

Always have replacement bulbs installed by an authorised Triumph dealer.

Headlight Bulb Replacement

LED Headlight Unit

The LED headlight unit is a sealed, maintenance-free LED unit.

Bulb Headlight Unit

Warning

The bulbs become hot during use. Always allow sufficient time for the bulb to cool before handling. Avoid touching the glass part of the bulb. If the glass is touched or gets dirty, clean with alcohol before reuse.

Maintenance

⚠ Caution

The use of non-approved headlight bulbs may result in damage to the headlight lens.

Use a genuine Triumph-supplied headlight bulb as specified in the Triumph Parts Catalogue.

Always have replacement headlight bulbs installed by an authorised Triumph dealer.

It is not necessary to remove the headlight unit when replacing the bulb.

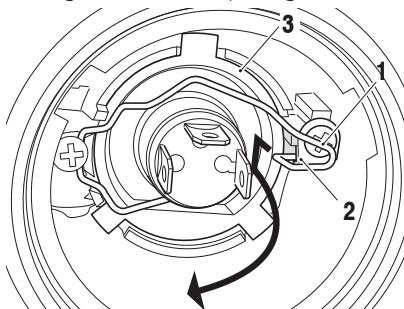

1. Bulb retainer (right hand shown)
2. Bulb retainer hook
3. Bulb

To replace a bulb:

- Remove the rider's seat.
- Disconnect the battery, negative (black) lead first.
- Remove the bulb cover from the bulb to be replaced by rotating it anticlockwise.
- Disconnect the multiplug from the bulb.
- Detach the bulb retainer from the hook on the headlight assembly and rotate it away from the bulb as shown.
- Remove the bulb from the bulb retainer.
- Installation is the reverse of the removal procedure.

Position Light Bulb Replacement

The position light is fitted to the centre of the headlight.

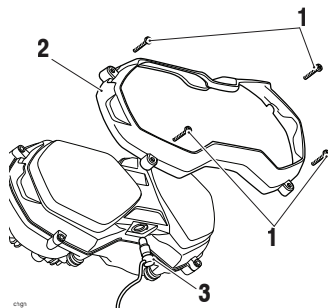

1. Fixings
2. Headlight surround
3. Position light bulb

To replace the bulb:

- Remove the four fixings.
- Remove the headlight surround.
- Detach the rubber retainer from the headlight and gently pull out the bulb.
- Installation is the reverse of the removal procedure.

Daytime Running Light (DRL) (if fitted)

The Daytime Running Light (DRL) is situated within the headlight assembly and is a sealed, maintenance-free LED unit. The headlight unit must be replaced in the event of the failure of the DRL.

Fog Lights (if fitted)

The fog light units are sealed, maintenance-free LED units.

Rear Light/Licence Plate Light

The rear light unit is a sealed, maintenance-free LED unit. The licence plate light is integral to the rear light unit.

Direction Indicator Lights

The motorcycle is fitted with either LED or bulb direction indicator lights.

LED Direction Indicator Lights

The direction indicator light units are sealed, maintenance-free LED units.

Bulb Direction Indicator Lights

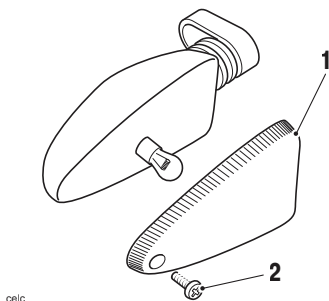

1. Indicator lens
2. Securing screw

The lens on each indicator light is held in place by a securing screw located in the lens of the light.

Release the screw and remove the lens to gain access to the bulb for replacement.

Cleaning and Storage

CLEANING AND STORAGE

Table of Contents

Cleaning.....	187
Preparation for Washing.....	187
Where to be Careful.....	188
Washing.....	188
After Washing.....	188
Care of Matt Paintwork.....	189
Care of Gloss Paintwork.....	189
Aluminium Items - not Lacquered or Painted.....	189
Cleaning of Chrome and Stainless Steel Items.....	190
Black Chrome.....	190
Cleaning of the Exhaust System.....	191
Seat Care.....	192
Windscreen Cleaning (if fitted).....	192
Care of Leather Products.....	193
Preparation for Storage.....	194
Preparation after Storage.....	195

Cleaning

Frequent, regular cleaning is an essential part of the maintenance of your motorcycle. If regularly cleaned, the appearance will be preserved for many years.

Cleaning with cold water containing an automotive cleaner is essential at all times but particularly so after exposure to sea breezes, sea water, dusty or muddy roads and in winter when roads are treated for ice and snow.

Do not use household detergent, as the use of such products will lead to premature corrosion.

Although, under the terms of your motorcycle warranty, cover is provided against the corrosion of certain items, the owner is expected to observe this reasonable advice which will safeguard against corrosion and enhance the appearance of the motorcycle.

Preparation for Washing

Before washing, precautions must be taken to keep water off the following places.

Rear opening of the exhausts: Cover with a plastic bag secured with rubber bands.

Clutch and brake levers, switch housings on the handlebar: Cover with plastic bags.

Ignition switch and steering lock: Cover the keyhole with tape.

Remove any items of jewellery such as rings, watches, zips or belt buckles, which may scratch or otherwise damage painted or polished surfaces.

Use separate cleaning sponges or cleaning cloths for washing painted/polished surfaces and chassis areas. Chassis areas (such as wheels and under mudguards) will be exposed to more abrasive road grime and dust, which may then scratch painted or polished surfaces, if the same sponge or cleaning cloths are used.

Cleaning and Storage

Where to be Careful

Caution

Do not spray any water at all near the air intake duct. The air intake duct is normally located under the rider's seat, under the fuel tank or near the steering head. Any water sprayed in this area could enter the airbox and engine, causing damage to both items.

Caution

Use of high pressure spray washers is not recommended. When using pressure washers, water may be forced into bearings and other components causing premature wear from corrosion and loss of lubrication.

Avoid spraying water with any great force near the following places:

- Instruments;
- Brake cylinders and brake calipers;
- Under the fuel tank;
- Air intake duct;
- Headstock bearings;
- Wheel bearings.

Note:

- **Use of soaps that are highly alkaline will leave a residue on painted surfaces, and may also cause water spotting. Always use a low alkaline soap to aid the cleaning process.**

Washing

Prepare a mixture of cold water and mild automotive cleaner. Do not use a highly alkaline soap as commonly found at commercial car washes because it leaves a residue.

Wash the motorcycle with a sponge or soft cloth. Do not use abrasive scouring pads or steel wool. They will damage the finish.

Rinse the motorcycle thoroughly with cold water.

After Washing

Warning

Never wax or lubricate the brake discs. Loss of braking power and an accident could result. Clean the disc with a proprietary brand of oil-free brake disc cleaner.

Remove the plastic bags and tape, and clear the air intakes.

Lubricate the pivots, bolts and nuts.

Test the brakes before motorcycle operation.

Use a dry cloth or chamois leather to absorb water residue. Do not allow water to stand on the motorcycle as this will lead to corrosion.

Start the engine and run it for 5 minutes. Make sure that there is adequate ventilation for the exhaust fumes.

Care of Matt Paintwork

Matt paintwork requires no greater care than that already recommended for high gloss paintwork.

- Do not use any polish or wax on matt paintwork.
- Do not try and polish out scratches.

Care of Gloss Paintwork

Gloss paintwork should be washed and dried as described above, then protected using a high quality automotive polish. Always follow the manufacturer's instructions and repeat regularly to maintain your motorcycle's appearance.

Aluminium Items - not Lacquered or Painted

Items such as brake and clutch levers, wheels, engine covers, engine cooling fins, upper and lower yokes and throttle bodies on some models must be correctly cleaned to preserve their appearance. Please contact your dealer if you are unsure which components on your motorcycle are aluminium parts not protected by paint or lacquer, and for guidance on how to clean those items.

Use a proprietary brand of aluminium cleaner which does not contain abrasive or caustic elements.

Clean aluminium items regularly, in particular after use in inclement weather, where the components must be hand washed and dried each time the machine is used.

Warranty claims due to inadequate maintenance will not be allowed.

Cleaning and Storage

Cleaning of Chrome and Stainless Steel Items

All chrome and stainless steel parts of your motorcycle must be cleaned regularly to avoid a deterioration of its appearance.

Washing

Wash as previously described.

Drying

Dry the chrome and stainless steel parts as far as possible with a soft cloth or chamois leather.

Protecting

 Caution
The use of products containing silicone will cause discolouration of the chrome and stainless steel parts and must not be used. Similarly, the use of abrasive cleaners will damage the finish and must not be used.

When the chrome and stainless steel is dry, apply a suitable proprietary chrome cleaner on to the surface, following the manufacturer's instructions.

It is recommended that regular protection be applied to the motorcycle as this will both protect and enhance its appearance.

Black Chrome

Items such as headlight bowls and mirrors on some models must be correctly cleaned to preserve their appearance. Please contact your dealer if you are unsure which components on your motorcycle are black chrome parts. Maintain the appearance of black chrome items by rubbing a small amount of light oil into the surface.

Cleaning of the Exhaust System

All parts of the exhaust system of your motorcycle must be cleaned regularly to avoid a deterioration of its appearance. These instructions can be applied to chrome, brushed stainless steel and carbon fibre components; matt painted exhaust systems should be cleaned as above, noting the care instructions in the Matt Paintwork section previously.

Note:

- **The exhaust system must be cool before washing to prevent water spotting.**

Washing

Wash as previously described.

Make sure that no soap or water enters the exhausts.

Drying

Dry the exhaust system as far as possible with a soft cloth or chamois leather. Do not run the engine to dry the system or spotting will occur.

Protecting



The use of products containing silicone will cause discolouration of the chrome and must not be used. Similarly, the use of abrasive cleaners will damage the system and must not be used.

When the exhaust system is dry, apply a suitable proprietary motorcycle protection spray onto the surface, following the manufacturer's instructions.

It is recommended that regular protection be applied to the system as this will both protect and enhance the system's appearance.

Cleaning and Storage

Seat Care

Caution

Use of chemicals or high pressure spray washers is not recommended for cleaning the seat.

Using chemicals or high pressure spray washers may damage the seat cover.

To help maintain its appearance, clean the seat using a sponge or cleaning cloth with soap and water.

Windscreen Cleaning (if fitted)



Warning

Never attempt to clean the windscreen while the motorcycle is in motion as releasing the handlebars may cause loss of motorcycle control and an accident.

Operation of the motorcycle with a damaged or scratched windscreen will reduce the rider's forward vision. Any such reduction in forward vision is dangerous and may lead to loss of motorcycle control and an accident.

Caution

Corrosive chemicals such as battery acid will damage the windscreen. Never allow corrosive chemicals to contact the windscreen.

Caution

Products such as window cleaning fluids, insect remover, rain repellent, scouring compounds, petrol or strong solvents such as alcohol, acetone, carbon tetrachloride, etc. will damage the windscreen.

Never allow these products to contact the windscreen.

Clean the windscreen with a solution of mild soap or detergent and cold water.

After cleaning, rinse well and then dry with a soft, lint-free cloth.

If the transparency of the windscreen is reduced by scratches or oxidation which cannot be removed, the windscreen must be replaced.

Care of Leather Products

We recommend that you periodically clean your leather products with a damp cloth and allow them to dry naturally at room temperature. This will maintain the appearance of the leather and ensure the long life of your product. Your Triumph leather product is a natural product and lack of care can result in damage and permanent wear. Follow these simple instructions and give your leather product the respect it deserves:

- Do not use household cleaning products, bleach, detergents containing bleach or any kind of solvent to clean your leather product.
- Do not immerse your leather product in water.
- Avoid direct heat from fires and radiators which can dry out and distort the leather.
- Do not leave your leather product in direct sunlight for prolonged periods of time.
- Do not dry your leather product by applying direct heat to it at any time.
- If your leather product does get wet, absorb any excess water with a soft clean cloth then leave the product to dry naturally at room temperature.
- Avoid exposure of your leather product to high levels of salt, for example sea/salt water or road surfaces that have been treated during the winter for ice and snow.

Cleaning and Storage

- If exposure to salt is unavoidable, clean your leather product immediately after each exposure using a damp cloth then leave the product to dry naturally at room temperature.
- Gently clean any minor marks with a damp cloth then leave the product to dry naturally at room temperature.
- Place your leather product in a fabric bag or cardboard box to protect it when in storage. Do not use a plastic bag.

Preparation for Storage

Clean and dry the entire vehicle thoroughly.

Fill the fuel tank with the correct grade of unleaded fuel and add a fuel stabiliser (if available), following the fuel stabiliser manufacturer's instructions.

Warning

Petrol is extremely flammable and can be explosive under certain conditions. Turn the ignition switch off. Do not smoke. Make sure the area is well ventilated and free from any source of flame or sparks; this includes any appliance with a pilot light.

Remove the spark plug from each cylinder and put several drops (5 cc) of engine oil into each cylinder. Cover the spark plug holes with a piece of cloth or rag. With the engine stop switch in the RUN position, push the starter button for a few seconds to coat the cylinder walls with oil. Install the spark plugs, tightening to **12 Nm**.

Change the engine oil and filter (see page **141**).

Check and if necessary correct the tyre pressures (see page **196**).

Set the motorcycle on a stand so that both wheels are raised off the ground. (If this cannot be done, put boards under the front and rear wheels to keep dampness away from the tyres.)

Spray rust inhibiting oil (there are a host of products on the market and your dealer will be able to offer you local advice) on all unpainted metal surfaces to prevent rusting. Prevent oil from getting on rubber parts, brake discs or in the brake calipers.

Lubricate and if necessary adjust the drive chain (see page **148**).

Make sure the cooling system is filled with a 50% mixture of coolant (noting that HD4X Hybrid OAT coolant, as supplied by Triumph, is pre-mixed and requires no dilution) and distilled water solution (see page **143**).

Remove the battery, and store it where it will not be exposed to direct sunlight, moisture, or freezing temperatures. During storage it should be given a slow charge (one Ampere or less) about once every two weeks (see page **173**).

Store the motorcycle in a cool, dry area, away from sunlight, and with a minimum daily temperature variation.

Put a suitable porous cover over the motorcycle to keep dust and dirt from collecting on it. Avoid using plastic or similar non-breathable, coated materials that restrict air flow and allow heat and moisture to accumulate.

Preparation after Storage

Install the battery (if removed) (see page **176**).

If the motorcycle has been stored for more than four months, change the engine oil (see page **141**).

Check all the points listed in the Daily Safety Checks section.

Before starting the engine, remove the spark plugs from each cylinder.

Put the side stand down.

Crank the engine on the starter motor several times until the oil pressure light goes out.

Refit the spark plugs, tightening to **12 Nm**, and start the engine.

Check and if necessary correct the tyre pressures.

Clean the entire vehicle thoroughly.

Check the brakes for correct operation.

Test ride the motorcycle at low speeds.

Specifications

SPECIFICATIONS

Dimensions, Weights and Performance

A list of model specific dimensions, weights and performance figures is available from your authorised Triumph dealer, or on the Internet at www.triumph.co.uk.

Payload	Tiger 800 XR - All Models	Tiger 800 XC - All Models
	222 kg (489 lbs)	222 kg (489 lbs)
Engine	Tiger 800 XR - All Models	Tiger 800 XC - All Models
Type	In-line 3 cylinder	In-line 3 cylinder
Displacement	800 cc	800 cc
Bore x Stroke	74.05 x 61.94 mm	74.05 x 61.94 mm
Compression Ratio	11.3:1	11.3:1
Cylinder Numbering	Left to Right	Left to Right
Cylinder Sequence	1 at left	1 at left
Firing Order	1-2-3	1-2-3
Starting System	Electric Starter	Electric Starter
Lubrication	Tiger 800 XR - All Models	Tiger 800 XC - All Models
Lubrication	Pressure Lubrication (wet sump)	Pressure Lubrication (wet sump)
Engine Oil Capacities		
Dry Fill	4.1 litres	4.1 litres
Oil/Filter Change	3.6 litres	3.6 litres
Oil Change Only	3.4 litres	3.4 litres
Cooling	Tiger 800 XR - All Models	Tiger 800 XC - All Models
Coolant Type	Triumph HD4X Hybrid OAT coolant	Triumph HD4X Hybrid OAT coolant
Water/Antifreeze Ratio	50/50 (premixed as supplied by Triumph)	50/50 (premixed as supplied by Triumph)
Coolant Capacity	2.69 litres	2.69 litres
Thermostat Opens (nominal)	88°C	88°C

Fuel System	Tiger 800 XR - All Models	Tiger 800 XC - All Models
Type	Electronic Fuel Injection	Electronic Fuel Injection
Injectors	Solenoid Operated	Solenoid Operated
Fuel Pump	Submerged Electric	Submerged Electric
Fuel Pressure (nominal)	3.5 bar	3.5 bar
Fuel	Tiger 800 XR - All Models	Tiger 800 XC - All Models
Type	91 RON unleaded	91 RON unleaded
Tank Capacity (motorcycle upright)	20.0 litres	20.0 litres
Ignition	Tiger 800 XR - All Models	Tiger 800 XC - All Models
Ignition System	Digital Inductive	Digital Inductive
Electronic Rev Limiter	10,000 r/min	10,000 r/min
Spark Plug	NGK CR9EK	NGK CR9EK
Spark Plug Gap	0.7 mm	0.7 mm
Gap Tolerance	+0.05/-0.1 mm	+0.05/-0.1 mm
Transmission	Tiger 800 XR - All Models	Tiger 800 XC - All Models
Transmission Type	6 Speed, Constant Mesh	6 Speed, Constant Mesh
Clutch Type	Wet, Multi-Plate	Wet, Multi-Plate
Final Drive Chain	DID O-ring, 124 link	DID O-ring, 124 link
Primary Drive Ratio	1.652:1 (76/46)	1.652:1 (76/46)
Gear Ratios:		
Final Drive Ratio	3.125:1 (50/16)	3.125:1 (50/16)
1st	2.615:1 (34/13)	2.615:1 (34/13)
2nd	1.857:1 (39/21)	1.857:1 (39/21)
3rd	1.500:1 (36/24)	1.500:1 (36/24)
4th	1.285:1 (27/21)	1.285:1 (27/21)
5th	1.136:1 (25/22)	1.136:1 (25/22)
6th	1.043:1 (24/23)	1.043:1 (24/23)

Approved Tyres

A list of approved tyres specific to these models is available from your authorised Triumph dealer, or on the Internet at www.triumph.co.uk.

Specifications

Approved Dual Purpose Tyres

A list of approved dual purpose tyres specific to these models is available from your authorised Triumph dealer, or on the Internet at www.triumph.co.uk.

Warning

Use the recommended tyres **ONLY** in the combinations given. Do not mix tyres from different manufacturers or mix different specification tyres from the same manufacturers as this may result in loss of motorcycle control and an accident.

	Tiger 800 XR - All Models	Tiger 800 XC - All Models
Tyre Sizes:		
Front Size	100/90 - 19 M/C 57V	90/90 - 21 M/C 54V
Rear Size	150/70 R 17 M/C 69V	150/70 R 17 M/C 69V
Tyre Pressures (Cold):		
Front	2.5 bar (36 lb/in ²)	2.5 bar (36 lb/in ²)
Rear	2.9 bar (42 lb/in ²)	2.9 bar (42 lb/in ²)

Warning

Tyre pressures which have been reduced for off-road riding will impair on-road stability. Always make sure that the tyre pressures are set as described in the tyre pressure charts for on-road use.

Operation of the motorcycle with incorrect tyre pressures may cause loss of motorcycle control leading to an accident.

Warning

The use of dual purpose tyres will result in reduced motorcycle stability. Always operate a motorcycle equipped with dual purpose tyres at reduced speeds. The permissible maximum speed must be indicated by a sticker, positioned so that it is clearly visible to the rider. Operation of the motorcycle above the permissible maximum speed may result in loss of motorcycle control and an accident.

Electrical Equipment	Tiger 800 XR - All Models	Tiger 800 XC - All Models
Battery Type	YTZ - 14S	YTZ - 14S
Battery Rating	12 Volt, 11.2 Ah	12 Volt, 11.2 Ah
Alternator	14 Volt, 34 Amp at 5,000 rpm	14 Volt, 34 Amp at 5,000 rpm
Headlight	2 x 12 Volt, 55/60 Watt, H4 Halogen (Tiger 800 XR and Tiger 800 XRX) LED (Tiger 800 XRT)	2 x 12 Volt, 55/60 Watt, H4 Halogen (Tiger 800 XCX) LED (Tiger 800 XCA)
Tail/Brake Light	LED	LED
Directional Indicator Lights	12 Volt, 10 Watt (market specific) LED	12 Volt, 10 Watt (market specific) LED
Fog Lights (if fitted)	LED	LED
Frame	Tiger 800 XR - All Models	Tiger 800 XC - All Models
Rake	23.5° 23.9° - Tiger 800 XRX - LRH	22.9°
Trail	85.0 mm 86.6 mm - Tiger 800 XRX - LRH	90.0 mm
Tightening Torques	All Models	
Oil Filter	10 Nm	
Oil Drain Plug	25 Nm	
Spark Plug	12 Nm	
Rear Wheel Spindle	110 Nm	
Chain Adjuster Lock Nut	15 Nm	

Specifications

Fluids and Lubrication

Engine Oil

Brake and Clutch Fluid

Coolant

Bearings and Pivots

Drive Chain

All Models

Semi or fully synthetic 10W/40 or 10W/50 motorcycle engine oil which meets specification API SH (or higher) and JASO MA, such as Castrol Power 1 Racing 4T 10W-40 (fully synthetic) engine oil, sold as Castrol Power RS Racing 4T 10W-40 (fully synthetic) in some countries.

DOT 4 Brake and Clutch Fluid

Triumph HD4X Hybrid OAT coolant

Grease to NLGI 2 specification

Chain spray suitable for O-ring chains

INDEX

- A**
- Accessories..... 130
 - Auto – Self-cancelling Indicators..... 73
- B**
- Bank Angle Indicators..... 167
 - Battery..... 173
 - Charging..... 176
 - Discharge..... 175
 - Disposal..... 175
 - Installation..... 177
 - Maintenance..... 175
 - Removal..... 174
 - Storage..... 175
 - Brakes..... 152
 - Accessory Rear Brake Reservoir..... 156
 - Brake and Clutch Lever Adjusters..... 88
 - Brake Wear Inspection..... 152
 - Braking..... 123
 - Breaking in New Pads and Discs..... 152
 - Disc Brake Fluid..... 154
 - Front Brake Fluid Inspection..... 154
 - Light Switches..... 156
 - Pad Wear Compensation..... 153
 - Rear Brake Fluid Inspection..... 155
- C**
- Changing Units..... 74
 - Cleaning
 - After Washing..... 188
 - Aluminium Items - not Lacquered or Painted..... 189
 - Black Chrome Items..... 190
 - Care of Leather Products..... 193
 - Chrome and Stainless Steel..... 190
 - Drying..... 191
 - Exhaust System..... 191
 - Frequency of Cleaning..... 187
 - Gloss Paintwork..... 189
 - Matt Paintwork..... 189
 - Preparation for Washing..... 187
 - Protecting..... 191
 - Seat Care..... 192
 - Washing..... 188
 - Washing the Exhaust..... 191
 - Where to be Careful..... 188
 - Windscreen..... 192
 - Clock Adjustment..... 71
 - Clutch..... 147
 - Adjustment..... 147
 - Inspection..... 147
 - Cooling System..... 143
 - Coolant Change..... 145
 - Cooling Level Adjustment..... 145
 - Cooling Level Inspection..... 144
 - Corrosion Inhibitors..... 143
 - High Coolant Temperature Warning Light..... 60
 - Specifications..... 196
 - Cruise Control
 - Activating..... 90
 - Adjusting the Set Speed..... 91
 - Cruise Control Adjust Button..... 81
 - Deactivating..... 91
 - Resuming the Set Speed..... 92
- D**
- Dimensions..... 196
 - Direction Indicator Lights..... 185
 - Bulb Unit..... 185
 - LED Unit..... 185
 - Drive Chain..... 148
 - Free Movement Adjustment..... 150
 - Free Movement Inspection..... 149
 - Lubrication..... 149
 - Wear Inspection..... 151
- E**
- Electrical Accessory Socket..... 109
 - Electrical Equipment
 - Specification..... 199
 - Engine
 - Moving Off..... 121
 - Serial Number..... 22
 - Specifications..... 196

Index

Starting the Engine	120
Stopping the Engine	119
Engine Oil	140
Disposal of Oil and Filters	142
Oil and Oil Filter Change	141
Oil Level Inspection	140
Specification and Grade	142

F

Fluids and Lubricants	200
Frame	
Rake	199
Trail	199
Front Suspension	158
Compression Damping Adjustment	160, 161
Front Fork Inspection	158
Rebound Damping Adjustment	162, 162
Setting Chart	159, 160

Fuel

Filling the Fuel Tank	99
Fuel Grade	97
Refuelling	98
Specifications	197
System Specifications	197

Fuses	178
-------	-----

G

Gears

Changing Gears	122
----------------	-----

H

Handlebar Adjustment	100
----------------------	-----

Headlights

Adjustment	181, 182
Bulb Headlight Unit	184
Bulb Replacement	183, 184
Daytime Running Lights (DRL)	185
Fog Lights	185
LED Headlight Unit	183
Position Light Bulb Replacement	184

Heated Seats

Heated Seat Switch	84
--------------------	----

Helmet Hook	108
-------------	-----

High Speed Operation	128
----------------------	-----

I

Ignition	78
----------	----

Key	78
-----	----

Specifications	197
----------------	-----

Immobiliser

Indicator Light	28, 58
-----------------	--------

Information Menu	66
------------------	----

Instrument Panel

Speedometer	63
-------------	----

Tachometer	63
------------	----

Trip Meters	66
-------------	----

Instruments

Description	23
-------------	----

Speedometer	32
-------------	----

Tachometer	32
------------	----

L

Left Handlebar Switches	81, 85
-------------------------	--------

Direction Indicator Switch	82, 85
----------------------------	--------

Fog Lights Switch	83, 87
-------------------	--------

Headlight Dip Switch	85
----------------------	----

Heated Grips Switch	83, 86
---------------------	--------

Heated Seat Switch	84
--------------------	----

High Beam Button	30, 84
------------------	--------

Horn Button	83, 85
-------------	--------

Instrument SCROLL Button	86
--------------------------	----

Instrument SET Button	86
-----------------------	----

Joystick Button	83
-----------------	----

MODE Button	82
-------------	----

Pass Button	86
-------------	----

Loading	130
---------	-----

Lubrication

Specifications	196
----------------	-----

Luggage System

Expedition Aluminium Pannier Installation	111
---	-----

Expedition Aluminium Pannier Operation	113
--	-----

Expedition Aluminium Pannier Removal	111
--------------------------------------	-----

Expedition Aluminium Panniers	111
-------------------------------	-----

M

Maintenance

Scheduled Maintenance	136
-----------------------	-----

O	
Off-road Use	5
P	
Parking	127
Parts Identification	16
Passengers	130
Performance	196
R	
Rear Light	
License Plate Light	185
Rear Suspension	163
Rebound Damping Adjustment	164
Settings Charts	165
Spring Preload Adjustment	163, 164
Right Handlebar Switches	79, 80
Daytime Running Lights (DRL) Switch	30, 82
Engine Stop Switch	79
Hazard Switch	30
Hazard Warning Lights	80
HOME Button	79
Starter Button	80
Running-In	116
S	
Safety	
Daily Checks	117
Fuel and Exhaust Fumes	8
Handlebars and Footrests	11
Helmet and Clothing	9
Maintenance and Equipment	13
Motorcycle	7
Parking	12
Parts and Accessories	13
Riding	10
Satellite Navigation Mounting Bracket	101
Seats	103
Heated Seats (if fitted)	105
Passenger Seat	103
Passenger Seat Refit	104
Passenger Seat Removal	103
Rider's Seat	104
Rider's Seat Height Adjustment	105
Rider's Seat Refit	105
Rider's Seat Removal	104
Seat Care	103, 192
Service Interval Indicator	65
Setup Menu	68
ABS Disable	70
ABS Enable	71
Triumph Traction Control (TTC) Disable	69
Stands	102
Centre Stand	102
Side Stand	102
Steering	
Inspection	157
Storage	
Preparation after Storage	195
Preparation for Storage	194
T	
TFT Digital Display	
Ambient Air Temperature	33
Fuel Gauge	33
Gear Position Display	32
Information Tray - Coolant Temperature	41
Information Tray - Fuel Information	39
Information Tray - Odometer	40
Information Tray - Overview	37
Information Tray - Screen Contrast	41
Information Tray - Service Interval Announcement	40
Information Tray - Style Options	41
Information Tray - Trip Meter	39
Information Tray - Tyre Pressure Monitoring	40
Information Tray - Warning Review	38
Instrument Panel Layout	25
Instrument Panel Position Adjustment	54
Main Menu - Bike Set Up - ABS	46
Main Menu - Bike Set Up - Direction Indicators	45
Main Menu - Bike Set Up - Service	46
Main Menu - Bike Set Up - Traction Control	46
Main Menu - Display Set Up - Brightness	50
Main Menu - Display Set Up - Language	51
Main Menu - Display Set Up - Set Clock	52

Index

Main Menu - Display Set Up - Set Units	51	Tyre Wear	169
Main Menu - Display Set Up - Themes and Styles	49	U	
Main Menu - Display Set Up - Visible Tray	51	Universal Serial Bus (USB) Socket	110
Main Menu - Reset to Defaults	53	V	
Main Menu - Riding Mode Configuration	44	Vehicle Identification Number	22
Main Menu - Riding Modes	43	W	
Main Menu - Trip 2 Enable/Disable	48	Warning Lights	57
Main Menu - Trip Setup	47	Warnings	4
Main Menu - Trip Setup - Automatic Reset	48	Immobiliser and TPMS	6
Main Menu - Trip Setup - Manual Reset	47	Maintenance	5
Main Menu Overview	42	Noise Control System	5
Riding Mode Selection	35	Owner's Handbook	3
Riding Modes	34	Warning Label Locations	14, 15
Service Interval Announcement	33	Warning Lights	27, 59
TFT Display Navigation	26	Weights	196
TFT Themes and Styles	26	Steering	158
Warning Lights	26		
Throttle Control	87, 146		
Tiger 800 XRX - LRH	6		
Tightening Torques	199		
Tool Kit	108		
Traction Control (TC)	93		
Disabled Warning Light	29, 59		
Indicator Light	28, 58		
Transmission			
Specifications	197		
Trip Computer	65		
Tyre Pressure Monitoring System (TPMS)	94		
Replacement Tyres	96		
Sensor Batteries	96		
Sensor Serial Number	95		
Symbol	96		
System Display	95		
Tyre Pressures	96		
Tyres	6, 167		
Inflation Pressures	198		
Minimum Tread Depth	170		
Replacement	170		
Tyre Inflation Pressures	169		
Tyre Pressure Monitoring System (TPMS)	169, 173		
Tyre Sizes	198		