

FOREWORD

This handbook contains information on the Triumph Sprint ST and Sprint GT motorcycles. Always store this owner's handbook with the motorcycle and refer to it for information whenever necessary.

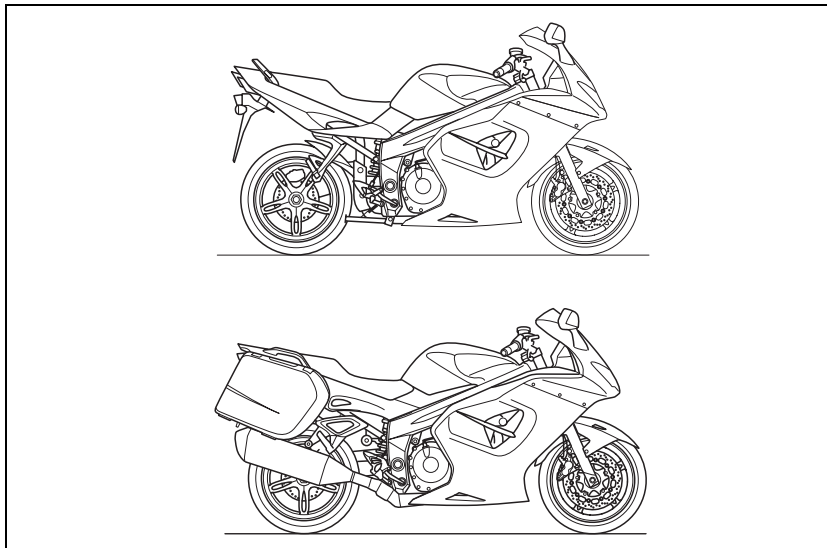

Warnings, Cautions and Notes

Throughout this owner's handbook particularly important information is presented in the following form:

Warning

This warning symbol identifies special instructions or procedures, which, if not correctly followed, could result in personal injury, or loss of life.

Caution

This caution symbol identifies special instructions or procedures, which, if not strictly observed, could result in damage to, or destruction of, equipment.

Note:

- **This note symbol indicates points of particular interest for more efficient and convenient operation.**

Foreword

Warning Labels

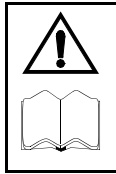

At certain areas of the motorcycle, the symbol (left) can be seen. The symbol means 'CAUTION: REFER TO THE HANDBOOK' and will be followed by a pictorial representation of the subject

concerned.

Never attempt to ride the motorcycle or make any adjustments without reference to the relevant instructions contained in this handbook.

See pages *10* and *11* for the location of all labels bearing this symbol. Where necessary, this symbol will also appear on the pages containing the relevant information.

Maintenance

To ensure a long, safe and trouble free life for your motorcycle, maintenance should only be carried out by an authorised Triumph dealer.

Only an authorised Triumph dealer will have the necessary knowledge, equipment and skills to maintain your Triumph motorcycle correctly.

To locate your nearest Triumph dealer, visit the Triumph web site at www.triumph.co.uk or telephone the authorised distributor in your country. Their address is given in the service record book that accompanies this handbook.

Noise Control System

Tampering with the Noise Control System is prohibited.

Owners are warned that the law may prohibit:

- a) The removal or rendering inoperative by any person other than for purposes of maintenance, repair or replacement, of any device or element of design incorporated into any new vehicle for the purpose of noise control prior to its sale or delivery to the ultimate purchaser or while it is in use and,
- b) the use of the vehicle after such device or element of design has been removed or rendered inoperative by any person.

Owner's Handbook

Thank you for choosing a Triumph motorcycle. This motorcycle is the product of Triumph's use of proven engineering, exhaustive testing, and continuous striving for superior reliability, safety and performance.

Please read this owner's handbook before riding in order to become thoroughly familiar with the correct operation of your motorcycle's controls, its features, capabilities and limitations.

This handbook includes safe riding tips, but does not contain all the techniques and skills necessary to ride a motorcycle safely.

Triumph strongly recommends that all riders undertake the necessary training to ensure safe operation of this motorcycle.

This handbook is also available from your local dealer in:

- Dutch;
- French;
- German;
- Italian;
- Japanese;
- Spanish;
- Swedish.

Warning

This owner's handbook, and all other instructions that are supplied with your motorcycle, should be considered a permanent part of your motorcycle and should remain with it even if your motorcycle is subsequently sold.

All riders must read this owner's handbook and all other instructions which are supplied with your motorcycle, before riding, in order to become thoroughly familiar with the correct operation of your motorcycle's controls, its features, capabilities and limitations. Do not lend your motorcycle to others as riding when not familiar with your motorcycle's controls, features, capabilities and limitations can lead to an accident.

Talk to Triumph

Our relationship with you does not end with the purchase of your Triumph. Your feedback on the buying and ownership experience is very important in helping us develop our products and services for you. Please help us by ensuring your dealership has your E-mail address and registers this with us. You will then receive an online customer satisfaction survey invitation to your E-mail address where you can give us this feedback.

Your Triumph Team.

Foreword

Information

The information contained in this publication is based on the latest information available at the time of printing. Triumph reserves the right to make changes at any time without prior notice, or obligation.

Not to be reproduced wholly or in part without the written permission of Triumph Motorcycles Limited.

© Copyright 04.2010 Triumph Motorcycles Limited, Hinckley, Leicestershire, England.

Publication part number 3856156 issue 1.

Table of Contents

This handbook contains a number of different sections. The table of contents below will help you find the beginning of each section where, in the case of the major sections, a further table of contents will help you find the specific subject required.

Foreword.....	1
Warning Labels.....	10
Parts Identification.....	12
Serial Numbers.....	17
General Information.....	19
How to Ride the Motorcycle.....	49
Accessories, Loading and Passengers.....	61
Maintenance and Adjustment.....	65
Storage.....	115
Specifications.....	117

Foreword - Safety First

FOREWORD - SAFETY FIRST

The Motorcycle

 **Warning**

This motorcycle is designed for on-road use only. It is not suitable for off-road use. Off-road operation could lead to loss of control of the motorcycle resulting in an accident causing injury or loss of life.

 **Warning**

This motorcycle is not designed to tow a trailer or be fitted with a sidecar. Fitting a sidecar and/or a trailer may result in loss of control and an accident.

 **Warning**

This motorcycle is designed for use as a two-wheeled vehicle capable of carrying a rider on his/her own, or a rider and one passenger (subject to a passenger seat being fitted).
The total weight of the rider, and any passenger, accessories and luggage must not exceed the maximum load limit of:
Sprint ST - 215 kg (473 lbs);
Sprint GT - 215 kg (473 lbs).

Fuel and Exhaust Fumes

 **Warning**

PETROL IS HIGHLY FLAMMABLE:

Always turn off the engine when refuelling. Do not refuel or open the fuel filler cap while smoking or in the vicinity of any open (naked) flame.

Take care not to spill any petrol on the engine, exhaust pipes or silencers when refuelling.

If petrol is swallowed, inhaled or allowed to get into the eyes, seek immediate medical attention.

Spillage on the skin should be immediately washed off with soap and water and clothing contaminated with petrol should immediately be removed.

Burns and other serious skin conditions may result from contact with petrol.

 **Warning**

Never start your engine or let it run for any length of time in a closed area. The exhaust fumes are poisonous and may cause loss of consciousness and death within a short time. Always operate your motorcycle in the open-air or in an area with adequate ventilation.

Foreword - Safety First

Riding

Warning

Never ride the motorcycle when fatigued or under the influence of alcohol or other drugs.

Riding when under the influence of alcohol or other drugs is illegal.

Riding when fatigued or under the influence of alcohol or other drugs reduces the rider's ability to maintain control of the motorcycle and may lead to loss of control and an accident.

Warning

All riders must be licenced to operate the motorcycle. Operation of the motorcycle without a licence is illegal and could lead to prosecution.

Operation of the motorcycle without formal training in the correct riding techniques that are necessary to become licenced is dangerous and may lead to loss of motorcycle control and an accident.

Warning

Always ride defensively and wear the protective equipment mentioned elsewhere in this foreword. Remember, in an accident, a motorcycle does not give the same impact protection as a car.

Warning

This Triumph motorcycle should be operated within the legal speed limits for the particular road travelled. Operating a motorcycle at high speeds can be potentially dangerous since the time available to react to given traffic situations is greatly reduced as road speed increases. Always reduce speed in potentially hazardous driving conditions such as bad weather or heavy traffic.

Warning

Continually observe and react to changes in road surface, traffic and wind conditions. All two-wheeled vehicles are subject to external forces which may cause an accident. These forces include but are not limited to:

- Wind draft from passing vehicles;
- Potholes, uneven or damaged road surfaces;
- Bad weather;
- Rider error.

Always operate the motorcycle at moderate speed and away from heavy traffic until you have become thoroughly familiar with its handling and operating characteristics. Never exceed the legal speed limit.

Foreword - Safety First

Helmet and Clothing

Warning

When riding the motorcycle, both rider and passenger must always wear a motorcycle helmet, eye protection, gloves, boots, trousers (close fitting around the knee and ankle) and a brightly coloured jacket. Brightly coloured clothing will considerably increase a rider's (or passenger's) visibility to other operators of road vehicles. Although full protection is not possible, wearing correct protective clothing can reduce the risk of injury when riding.

Warning

A helmet is one of the most important pieces of riding gear as it offers protection against head injuries. You and your passenger's helmet should be carefully chosen and should fit you or your passenger's head comfortably and securely. A brightly coloured helmet will increase a rider's (or passenger's) visibility to other operators of road vehicles.

An open face helmet offers some protection in an accident though a full face helmet will offer more.

Always wear a visor or approved goggles to help vision and to protect your eyes.



Handlebars and Footrests

Warning

The rider must maintain control of the vehicle by keeping hands on the handlebars at all times.

The handling and stability of a motorcycle will be adversely affected if the rider removes his hands from the handlebars, resulting in loss of motorcycle control and an accident.

Warning

The rider and passenger must always use the footrests provided, during operation of the vehicle.

By using the footrests, both rider and passenger will reduce the risk of inadvertent contact with any motorcycle components and will also reduce the risk of injury from entrapment of clothing.

Foreword - Safety First

Parking

Warning

Always turn off the engine and remove the ignition key before leaving the motorcycle unattended. By removing the key, the risk of use of the motorcycle by unauthorised or untrained persons is reduced.

When parking the motorcycle, always remember the following:

Engage first gear to help prevent the motorcycle from rolling off the stand.

The engine and exhaust system will be hot after riding. DO NOT park where pedestrians, animals and/or children are likely to touch the motorcycle.

Do not park on soft ground or on a steeply inclined surface. Parking under these conditions may cause the motorcycle to fall over.

For further details, please refer to the 'How to Ride the Motorcycle' section of this owner's handbook.

Parts and Accessories

Warning

Owners should be aware that the only approved parts, accessories and conversions for any Triumph motorcycle are those which carry official Triumph approval and are fitted to the motorcycle by an authorised dealer.

In particular, it is extremely hazardous to fit or replace parts or accessories whose fitting requires the dismantling of, or addition to, either the electrical or fuel systems and any such modification could cause a safety hazard.

The fitting of any non-approved parts, accessories or conversions may adversely affect the handling, stability or other aspect of the motorcycle operation that may result in an accident causing injury or death.

Triumph does not accept any liability whatsoever for defects caused by the fitting of non-approved parts, accessories or conversions or the fitting of any approved parts, accessories or conversions by non-approved personnel.

Foreword - Safety First

Maintenance/Equipment

Warning

Consult your authorised Triumph dealer whenever there is doubt as to the correct or safe operation of this Triumph motorcycle.

Remember that continued operation of an incorrectly performing motorcycle may aggravate a fault and may also compromise safety.

Warning

Ensure all equipment that is required by law is installed and functioning correctly. The removal or alteration of the motorcycle's lights, silencers, emission or noise control systems can violate the law. Incorrect or improper modification may adversely affect the handling, stability or other aspect of the motorcycle operation, which may result in an accident causing injury or death.

Warning

Use of a motorcycle with bank angle indicators worn beyond the maximum limit will allow the motorcycle to be banked to an unsafe angle.

The maximum bank angle wear limits are:

- Sprint ST - **5 mm** remaining;
- Sprint GT - **15 mm** remaining.

Banking to an unsafe angle may cause instability, loss of motorcycle control and an accident.

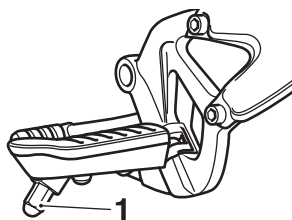

ccsm

1. Bank angle indicator

Warning

If the motorcycle is involved in an accident, collision or fall, it must be taken to an authorised Triumph dealer for inspection and repair. Any accident can cause damage to the motorcycle that, if not correctly repaired, may cause a second accident that may result in injury or death.

Warning Labels

WARNING LABELS

The labels detailed on this and the following pages draw your attention to important safety information in this handbook. Before riding, ensure that all riders have understood and complied with all the information to which these labels relate.

Warning Label Locations

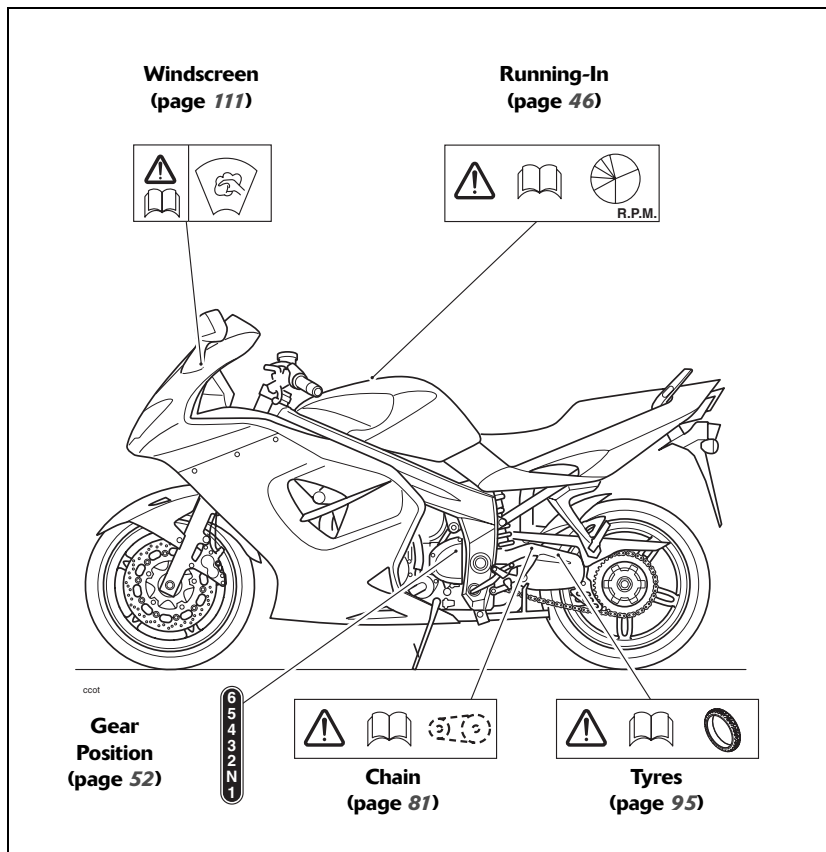

Warning Labels

Warning Label Locations (continued)

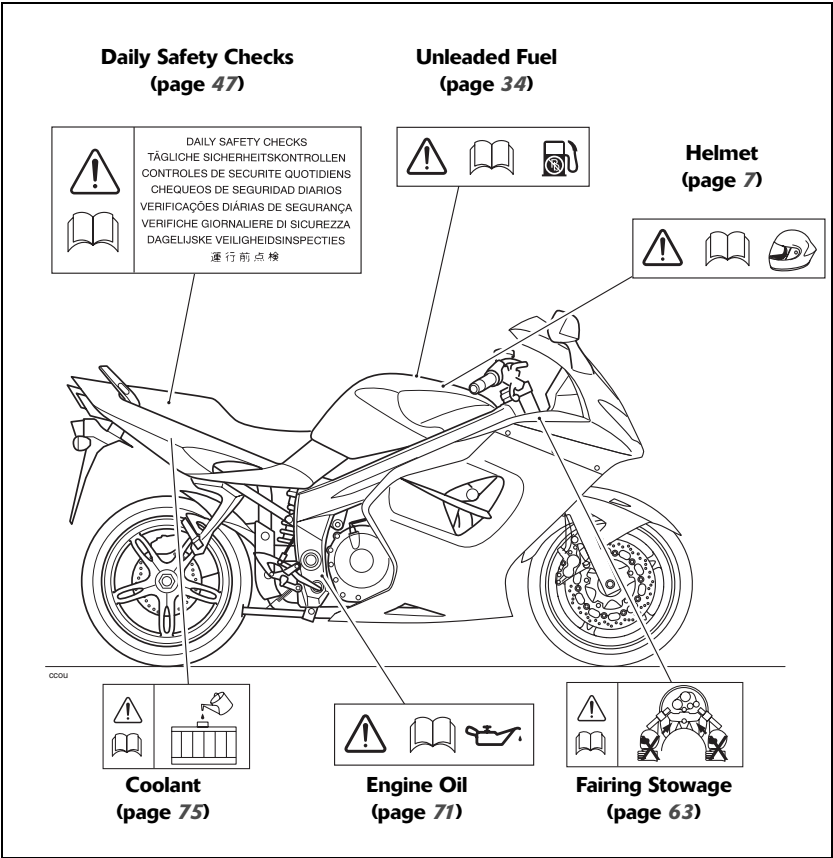

Parts Identification

PARTS IDENTIFICATION

Sprint ST

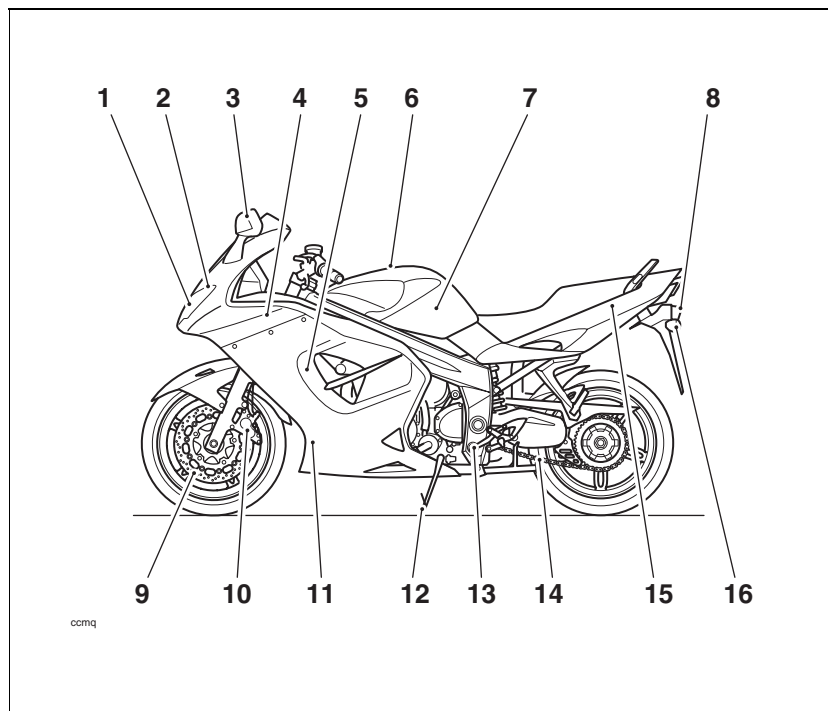

- | | |
|----------------------------------|-------------------------|
| 1. Headlight | 9. Front brake disc |
| 2. Position lamp | 10. Front brake caliper |
| 3. Front indicator | 11. Oil cooler |
| 4. Coolant expansion tank | 12. Side stand |
| 5. Radiator/Coolant pressure cap | 13. Gear-change pedal |
| 6. Fuel filler cap | 14. Drive chain |
| 7. Fuel tank | 15. Silencer |
| 8. Rear light | 16. Rear indicator |

Parts Identification

Sprint ST

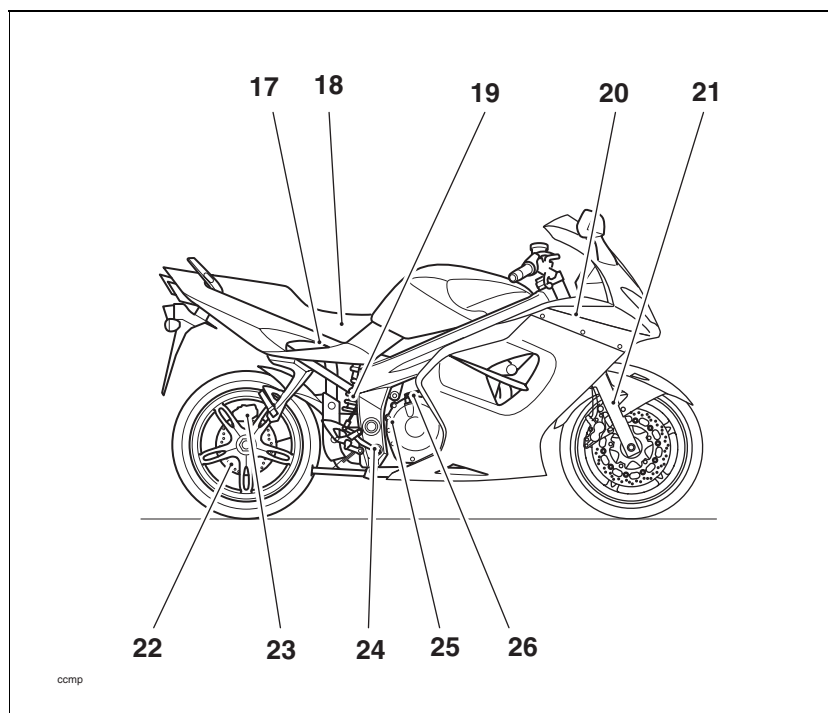

17. Rear brake fluid reservoir

18. Battery

19. Rear suspension unit

20. Tool kit

21. Front fork

22. Rear brake disc

23. Rear brake caliper

24. Rear brake pedal

25. Oil filler cap/Dipstick

26. Clutch cable

Parts Identification

PARTS IDENTIFICATION

Sprint GT

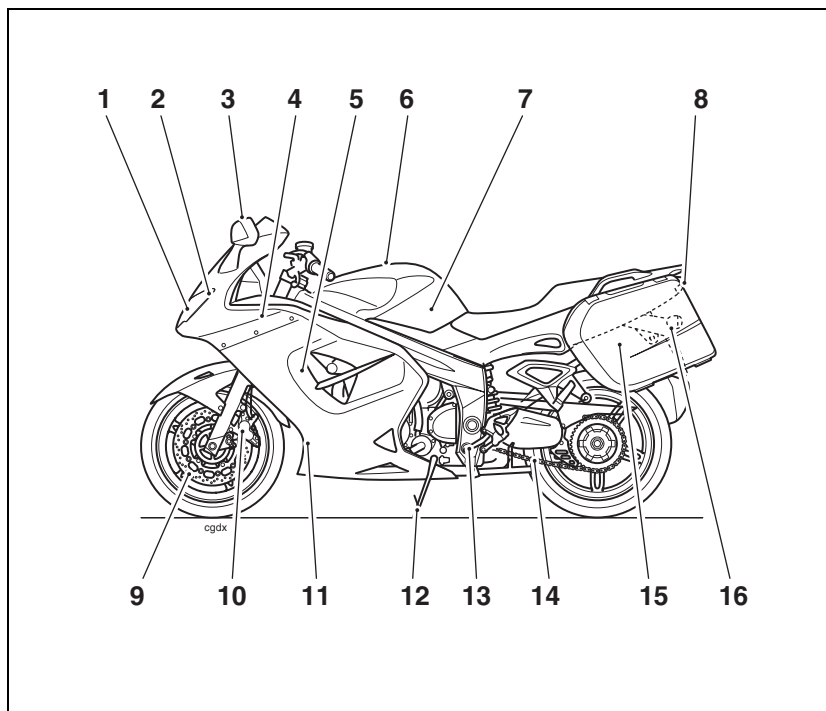

- | | |
|----------------------------------|-------------------------|
| 1. Headlight | 9. Front brake disc |
| 2. Position lamp | 10. Front brake caliper |
| 3. Front indicator | 11. Oil cooler |
| 4. Coolant expansion tank | 12. Side stand |
| 5. Radiator/Coolant pressure cap | 13. Gear-change pedal |
| 6. Fuel filler cap | 14. Drive chain |
| 7. Fuel tank | 15. Pannier |
| 8. Rear light | 16. Rear indicator |

Parts Identification

Sprint GT

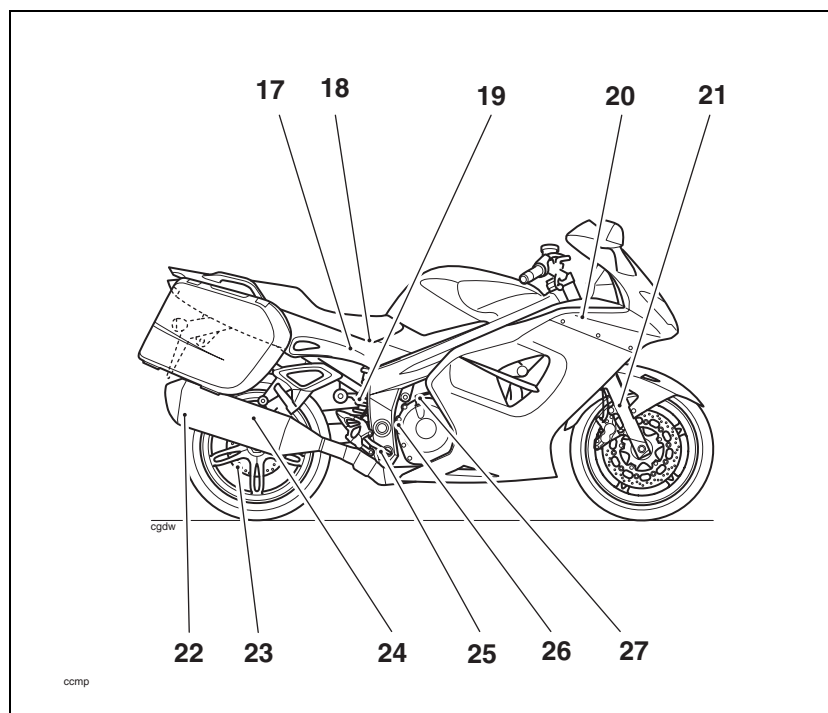

17. Rear brake fluid reservoir

18. Battery

19. Rear suspension unit

20. Tool kit

21. Front fork

22. Silencer

23. Rear brake disc

24. Rear brake caliper

25. Rear brake pedal

26. Oil filler cap/Dipstick

27. Clutch cable

Parts Identification

Parts Identification (continued) - Sprint ST and GT

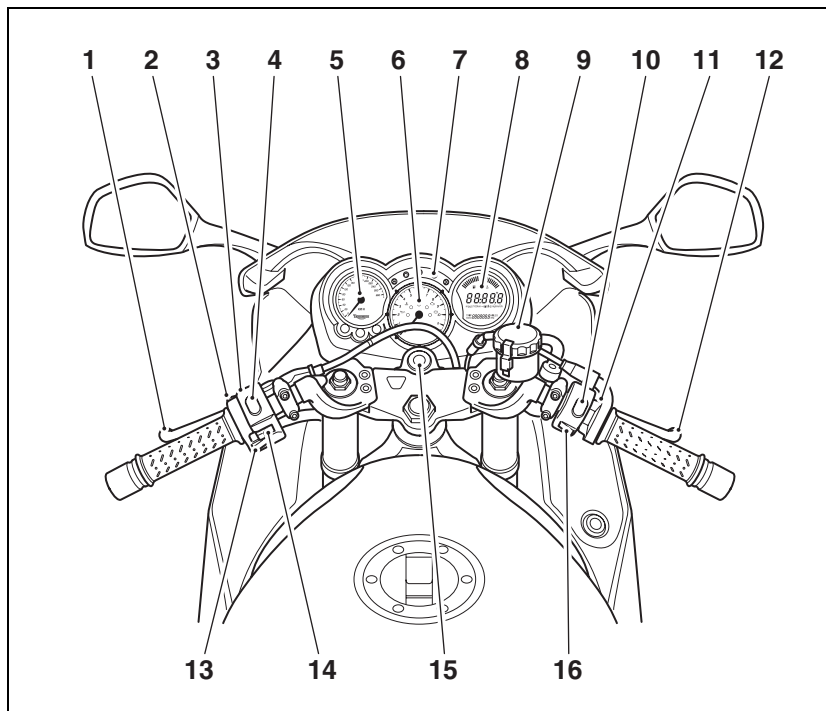

- | | |
|--------------------------|--------------------------------|
| 1. Clutch lever | 9. Front brake fluid reservoir |
| 2. Passing button | 10. Engine stop switch |
| 3. Clutch lever adjuster | 11. Brake lever adjuster |
| 4. Headlight dip switch | 12. Front brake lever |
| 5. Speedometer | 13. Horn button |
| 6. Tachometer | 14. Direction indicator switch |
| 7. Warning lights | 15. Ignition switch |
| 8. Trip computer | 16. Starter button |

Serial Numbers

SERIAL NUMBERS

Vehicle Identification Number (VIN)

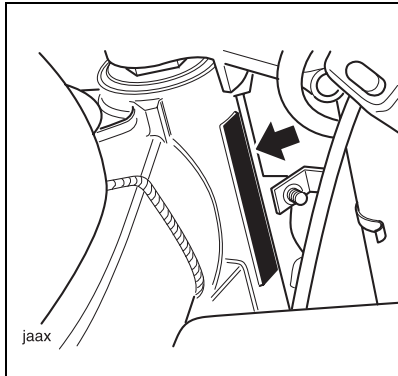

The vehicle identification number is stamped into the steering head area of the frame. It is also displayed on a plate, riveted to the frame, immediately behind the steering head.

Record the vehicle identification number in the space below.

Engine Serial Number

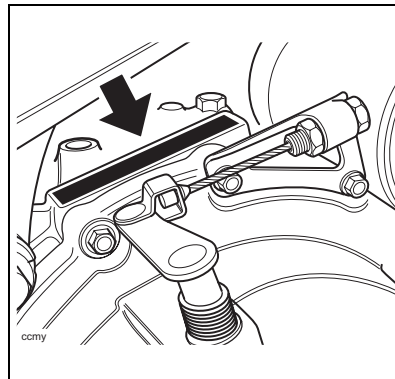

The engine serial number is stamped on the engine crankcase, immediately above the clutch cover.

Record the engine serial number in the space provided below.

Serial Numbers

This page intentionally left blank

GENERAL INFORMATION

Table of Contents

Instrument Panel Layout 21

Speedometer 22

Tachometer 22

Odometer/Trip Meter 22

Clock/Trip Computer 23

 Instantaneous Fuel Consumption 23

 Average Fuel Consumption 23

 Range 23

 Journey Distance 23

 Journey Time 23

 Average Speed 23

 Maximum Speed 23

 Trip Computer Operation 23

 Trip Computer Reset 24

 Clock Adjustment 24

Coolant Temperature Gauge 25

Fuel Gauge 26

Warning Lights 27

 Direction Indicators 27

 High Beam 27

 Low Fuel 27

 Neutral 27

 Low Oil Pressure Warning Light 27

 High Coolant Temperature Warning Light 27

 Engine Management System Malfunction Indicator Light 28

 Alarm Indicator Light 28

 ABS (Anti-Lock Brake System) Indicator Light - Sprint GT only 29

Ignition Key 29

Ignition Switch/Steering Lock 30

 Ignition Switch Positions 30

General Information

Brake and Clutch Lever Adjusters	31
Right Handlebar Switches	32
Engine Stop Switch	32
Starter Button	33
Left Handlebar Switches	33
Headlight Dip Switch	33
Direction Indicator Switch	34
Horn Button	34
Pass Button	34
Fuel Requirement/Refuelling	34
Fuel Grade	34
Fuel Tank Cap	35
Filling the Fuel Tank	36
Stands	37
Side Stand	37
Centre Stand	37
Lifting Handle	38
Tool Kit and Handbook	38
Seat - Sprint ST	39
Seat - Sprint GT	39
Seat Care	40
Helmet Hooks - Sprint GT	40
Triumph Accessory D-lock Storage - Sprint GT models only	41
Pannier System - Sprint GT	41
Pannier Operation	43
Electrical Accessory Socket	46
Running-In	46
Safe Operation	47
Daily Safety Checks	47

General Information

Instrument Panel Layout

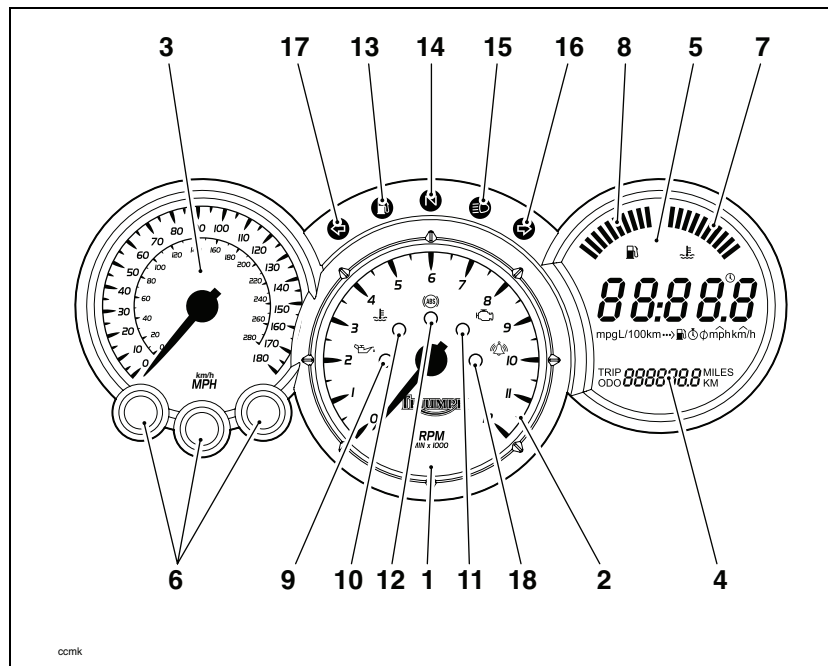

(Sprint ST shown, Sprint GT similar)

1. Tachometer
2. Tachometer 'red zone'
3. Speedometer
4. Odometer/Trip meters
5. Clock/Trip computer display
6. Scroll/Set/Trip buttons
7. Coolant temperature display
8. Fuel gauge
9. Low oil pressure warning light
10. High coolant temperature warning light
11. Engine management malfunction indicator light
12. ABS warning light (ABS models only)
13. Low fuel level indicator light
14. Neutral indicator light
15. High beam indicator light
16. Right turn indicator light
17. Left turn indicator light
18. Alarm status indicator light (alarm is an accessory fit)

General Information

Speedometer

The speedometer indicates the road speed of the motorcycle.

Tachometer

The tachometer shows the engine speed in revolutions per minute - rpm (r/min). On the right side of the tachometer face is the 'red zone'. Engine rpm (r/min) in the red zone is above maximum recommended engine speed and is also above the range for best performance.

Warning

Never allow engine rpm to enter the 'red zone' as severe engine damage may result.

Odometer/Trip Meter

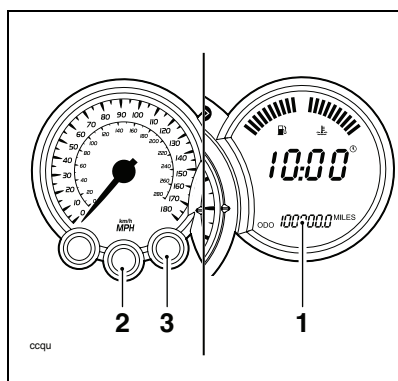

1. Odometer/Trip meter display
2. Set button
3. Trip button

The odometer shows the total distance that the motorcycle has travelled.

The odometer and two trip meters are located in the same LCD display as the clock and trip computer. Either trip meter shows the distance that the motorcycle has travelled since the meter on display was last reset to zero.

Warning

Do not attempt to switch between odometer and trip meter display modes or reset the trip meter with the motorcycle in motion as this may lead to loss of motorcycle control and an accident.

Use the 'trip' button to switch between the odometer and trip meter display modes. Press the 'trip' button repeatedly until the desired display is visible. The display will scroll through in the order:

- Odometer
- Trip Meter 1
- Trip Meter 2

To reset either of the trip meters, select and display the trip meter to be zeroed then press the 'trip' button for 2 seconds. After 2 seconds, the trip meter on display will reset to zero.

General Information

Trip Computer Reset

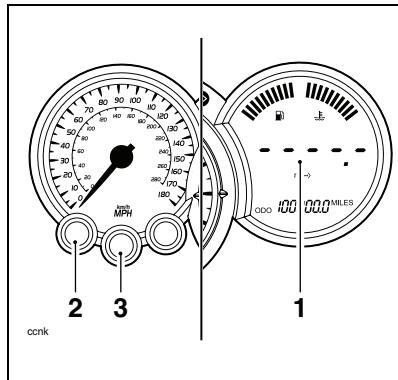

1. Trip computer display
2. Scroll button
3. Set button

The following displays on the trip computer can be reset:

- Average Fuel Consumption
- Journey Distance
- Journey Time
- Average Speed
- Maximum Speed

Warning

Do not attempt to switch between the trip computer display modes or reset the trip computer with the motorcycle in motion as this may lead to loss of motorcycle control and an accident.

To reset the trip computer select the desired display, press the 'scroll' and 'set' buttons simultaneously for 2 seconds. After 2 seconds, the selected display will reset.

Note:

- **Journey distance, journey time and average speed are reset at the same time.**

Clock Adjustment

Warning

Do not attempt to adjust the clock with the motorcycle in motion as this may lead to loss of motorcycle control and an accident.

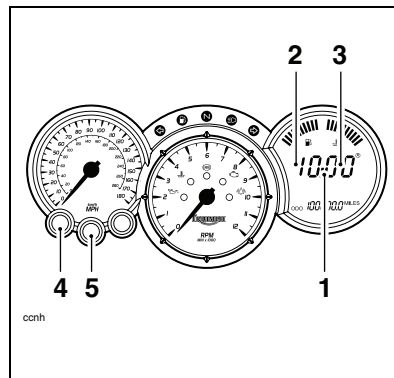

1. Clock display
2. Hours read-out
3. Minutes read-out
4. Scroll button
5. Set button

To reset the clock, select the clock display and press both 'scroll' and 'set' buttons together.

General Information

After a short time, the clock's hour display will start to flash.

To reset the hour display, ensure that the hour display is still flashing then depress the 'scroll' button to change the setting. Each individual press will change the setting by one digit. If the button is held, the display will continuously scroll through in single digit increments.

When the correct hour display is shown, press the 'set' button. The minutes display will begin to flash. The minutes display is adjusted in the same way as for the hours.

Once both hours and minutes are correctly set, press the 'set' button to confirm the setting. The display will cease to flash.

Coolant Temperature Gauge

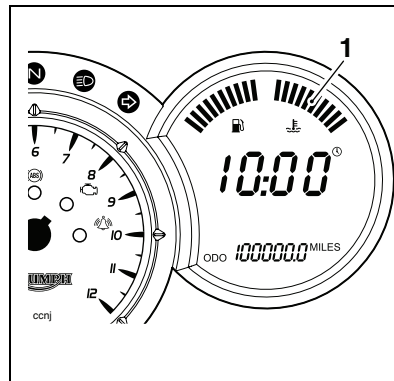

1. Coolant temperature gauge

The coolant temperature gauge indicates the temperature of the engine coolant.

When the ignition is switched on, all 10 bars of the display will be shown. When the engine is started from cold the display will show 1 bar. As the temperature increases, more bars will be shown in the display.

The normal temperature range is between 3 and 6 bars.

If the coolant temperature becomes too high, the display will show 9 bars and will start to flash. The high coolant temperature warning light in the tachometer will also be illuminated.

If the coolant temperature increases further, all 10 bars of the display will flash. The high coolant temperature warning light in the tachometer will remain illuminated.

General Information

Caution

Do not continue to run the engine if either of the high temperature warnings are displayed as severe engine damage may result.

Fuel Gauge

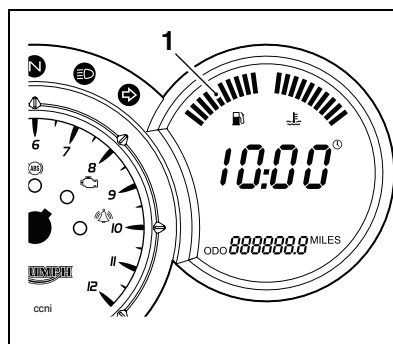

1. Fuel gauge

The fuel gauge indicates the amount of fuel in the tank.

With the ignition switched on, the number of bars shown in the display indicates the level of fuel in the tank.

When the fuel tank is full, all 10 bars are displayed and when empty, no bars are displayed. Other gauge markings indicate intermediate fuel levels between full and empty.

When 2 bars are displayed, the low fuel warning light will illuminate. This indicates there are approximately 4.0 litres of fuel remaining in the tank and you should refuel at the earliest opportunity.

After refuelling, the fuel gauge and range to empty information will be updated only while riding the motorcycle.

Depending on the riding style, this could take approximately 5 minutes.

General Information

Warning Lights

Direction Indicators



When the indicator is pushed to the left or right, the corresponding turn indicator light will flash on and off at the same speed as the turn indicators.

High Beam



When the ignition is switched on and the headlight dip switch is set to 'high beam', the high beam warning light will illuminate.

Low Fuel



The low fuel indicator will illuminate when there are approximately 4.0 litres of fuel remaining in the tank.

Neutral



The neutral warning light indicates when the transmission is in neutral (no gear selected). The warning light will illuminate when the transmission is in neutral with the ignition switch in the ON position.

Low Oil Pressure Warning Light



With the engine running, if the engine oil pressure becomes dangerously low, the low oil pressure warning light in the tachometer will illuminate.

Caution

Stop the engine immediately if the low oil pressure warning light illuminates. Do not restart the engine until the fault has been rectified.

Severe engine damage will result from running the engine when the low oil pressure warning light is illuminated.

The low oil pressure warning light in the tachometer will illuminate if the ignition is switched on without running the engine.

High Coolant Temperature Warning Light



With the engine running, if the engine coolant temperature becomes dangerously high, the high coolant temperature warning light in the tachometer will illuminate.

Caution

Stop the engine immediately if the high coolant temperature warning light illuminates. Do not restart the engine until the fault has been rectified.

Severe engine damage will result from running the engine when the high coolant temperature warning light is illuminated.

The high coolant temperature warning light in the tachometer will illuminate if the ignition is switched on without running the engine.

General Information

Engine Management System Malfunction Indicator Light



The malfunction indicator light for the engine management system illuminates when the ignition is switched on (to indicate that it is working) but should not become illuminated when the engine is running.

If the malfunction indicator light becomes illuminated when the engine is running, this indicates that a fault has occurred in one or more of the systems controlled by the engine management system. In such circumstances, the engine management system will switch to 'limp-home' mode so that the journey may be completed, if the fault is not so severe that the engine will not run.

Note:

- **If the malfunction indicator light flashes when the ignition is switched on, contact an authorised Triumph dealer as soon as possible to have the situation rectified. In these circumstances the engine will not start.**

Alarm Indicator Light



The alarm light will illuminate when the conditions described in the accessory alarm instructions are met.

The light does not function unless an alarm is fitted.

Warning

Reduce speed and do not continue to ride for longer than is necessary with the malfunction indicator light illuminated. The fault may adversely affect engine performance, exhaust emissions and fuel consumption. Reduced engine performance could cause a dangerous riding condition, leading to loss of control and an accident. Contact an authorised Triumph dealer as soon as possible to have the fault checked and rectified.

General Information

ABS (Anti-Lock Brake System) Indicator Light - Sprint GT only



The ABS indicator light illuminates to show that the ABS function is not available. Illumination is normal after engine start-up, and until the motorcycle first reaches a speed exceeding 6 mph (10 km/h). Unless there is a fault, it should not illuminate again until the engine is restarted.

If the indicator light becomes illuminated at any other time while riding it indicates that the ABS has a malfunction that requires investigation.

Warning

If the ABS is not functioning, the brake system will continue to function as a non-ABS braking system. Do not continue to ride for longer than is necessary with the indicator light illuminated. Contact an authorised Triumph dealer as soon as possible to have the fault checked and rectified. In this situation, braking too hard will cause the wheels to lock resulting in loss of control and an accident.

See also Braking on page 53.

Ignition Key

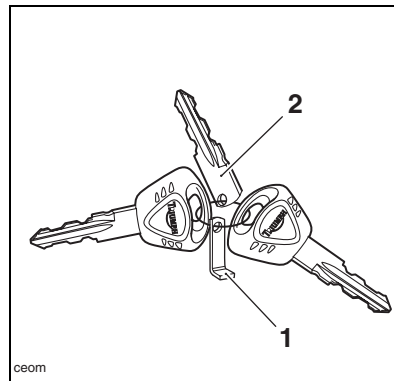

1. Key number tag

2. Key blade for alarm system

In addition to operating the steering lock/ignition switch, the ignition key is required to operate the seat lock and fuel tank cap.

When the motorcycle is delivered from the factory, two ignition keys are supplied together with a small tag bearing the key number, and a spare key blade for use with Triumph accessory alarm. Make a note of the key number and store the spare key, key blade and key number tag in a safe place away from the motorcycle.

Your authorised Triumph dealer can supply a replacement key cut from details of the key number or can cut a new key using the original as a master.

General Information

Note:

- On Sprint ST models, three unused locks are supplied with the motorcycle. These are for use with the optional accessory panniers and top box and will ensure that, when fitted, the same key will operate all the locks on the motorcycle.
- On Sprint GT models, one unused lock is supplied with the motorcycle. This is for use with the optional accessory top box and will ensure that, when fitted, the same key will operate all the locks on the motorcycle.

Caution

Do not store the spare key with the motorcycle as this will reduce all aspects of security.

Ignition Switch/Steering Lock

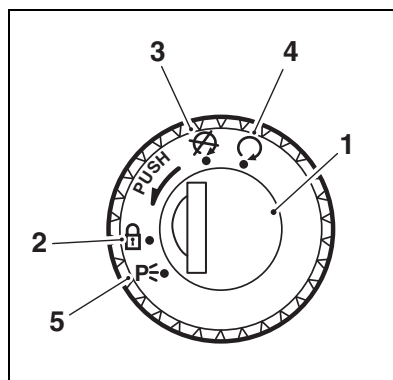

1. Ignition switch/Steering lock
2. LOCK position
3. OFF position
4. ON position
5. PARK position

Ignition Switch Positions

This is a four position, key operated switch. The key can be removed from the switch only when it is in the OFF, LOCK or P (PARK) position.

TO LOCK: Turn the key to the OFF position, push and fully release the key, then rotate it to the LOCK position.

PARKING: Turn the key from the LOCK position to the P position. The steering will remain locked.

General Information

Note:

- **Do not leave the steering lock in the P position for long periods of time as this will cause the battery to discharge.**

Warning

For reasons of security and safety, always move the ignition switch to the OFF position and remove the key when leaving the motorcycle unattended.

Any unauthorised use of the motorcycle may cause injury to the rider, other road users and pedestrians and may also cause damage to the motorcycle.

Warning

With the key in the LOCK or P position the steering will become locked.

Never turn the key to the LOCK or P positions while the motorcycle is moving as this will cause the steering to lock. Locked steering will cause loss of motorcycle control and an accident.

Brake and Clutch Lever Adjusters

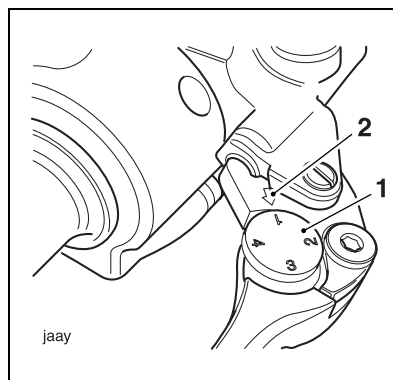

1. Adjuster wheel

2. Triangular mark

An adjuster is fitted to both the front brake and clutch levers. The adjusters allow the distance from the handlebar to the levers to be changed to one of four positions, to suit the span of the operator's hands.

To adjust the levers, push each lever forward and turn the adjuster wheel to align one of the numbered positions with the triangular mark on the lever holder.

The distance from the handlebar grip to the released lever is shortest when set to number four and longest when set to number one.

General Information

Warning

Do not attempt to adjust the levers with the motorcycle in motion as this may lead to loss of motorcycle control and an accident. After adjusting the levers, operate the motorcycle in an area free from traffic to gain familiarity with the new lever setting. Do not loan your motorcycle to anyone as they may change the lever setting from the one you are familiar with causing loss of control or an accident.

Right Handlebar Switches

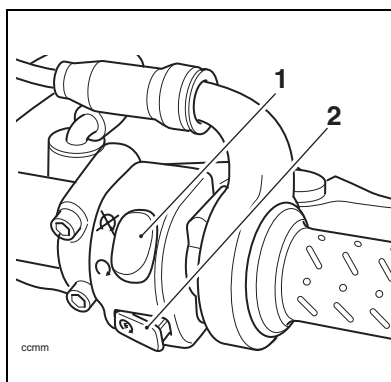

1. Engine stop switch
2. Starter button

Engine Stop Switch

In addition to the ignition switch being turned to the ON position, the engine stop switch must be in the RUN position for the motorcycle to operate.

The engine stop switch is for emergency use. If an emergency arises which requires the engine to be stopped, move the engine stop switch to the STOP position.

Note:

- **Although the engine stop switch stops the engine, it does not turn off all the electrical circuits and may cause difficulty in restarting the engine due to a discharged battery. Ordinarily, only the ignition switch should be used to stop the engine.**

General Information

Caution

Do not leave the ignition switch in the ON position unless the engine is running as this may cause damage to electrical components and will discharge the battery.

Starter Button

The starter button operates the electric starter. For the starter to operate, the clutch lever must be pulled to the handlebar.

Note:

- **Even if the clutch lever is pulled to the handlebar, the starter will not operate if the side stand is down and a gear is engaged.**

Left Handlebar Switches

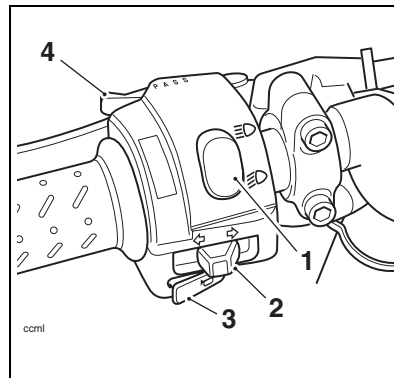

1. Headlight dip switch
2. Direction indicator switch
3. Horn button
4. Pass button

Headlight Dip Switch

High or low beam can be selected with the headlight dip switch. To select high beam, push the switch forward. To select low beam, push the switch rearwards. When the high beam is turned on, the high beam indicator light will illuminate.

Note:

- **A lighting on/off switch is not fitted to this model. The headlight, rear light and licence plate light all function automatically when the ignition is turned to the ON position.**

General Information

Direction Indicator Switch

When the indicator switch is pushed to the left or right and released, the corresponding direction indicators will flash on and off. To turn off the indicators, push and release the switch.

Horn Button

When the horn button is pushed, with the ignition switch turned to the ON position, the horn will sound.

Pass Button

When the pass button is pressed, the headlight main beam will be switched on. It will remain on as long as the button is held in and will turn off as soon as the button is released.

Fuel Requirement/Refuelling

Fuel Grade



Your Triumph engine is designed to use unleaded fuel and will give optimum performance if the correct grade of fuel is used. Always use unleaded fuel with an octane rating of 95 RON.

Caution

In all countries except Australia, Hong Kong, New Zealand and South Africa, the exhaust system for this model is fitted with a catalytic converter to help reduce exhaust emission levels. The catalytic converter can be permanently damaged if the motorcycle is allowed to run out of fuel or if the fuel level is allowed to get very low. Always ensure you have adequate fuel for your journey.

Caution

The use of leaded fuel is illegal in most countries, states or territories. Use of leaded fuel will damage the catalytic converter (if fitted).

General Information

Warning

To help reduce hazards associated with refuelling, always observe the following fuel safety instructions:

Petrol (fuel) is highly flammable and can be explosive under certain conditions. When refuelling, turn the ignition switch to the OFF position.

Do not smoke.

Do not use a mobile telephone.

Make sure the refuelling area is well ventilated and free from any source of flame or sparks. This includes any appliance with a pilot light.

Never fill the tank until the fuel level rises into the filler neck. Heat from sunlight or other sources may cause the fuel to expand and overflow creating a fire hazard.

After refuelling always check that the fuel filler cap is correctly closed and locked.

Because petrol (fuel) is highly flammable, any fuel leak or spillage, or any failure to observe the safety advice given above will lead to a fire hazard, which could cause damage to property, injury to persons or death.

Fuel Tank Cap

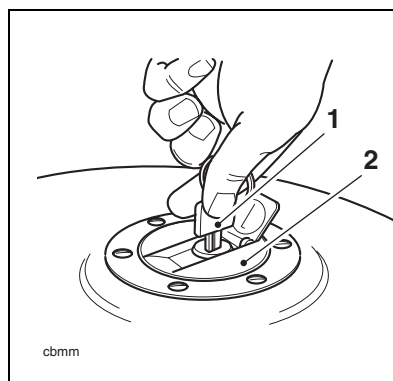

1. Ignition switch key

2. Fuel tank cap

To open the fuel tank cap, lift up the flap covering the lock itself. Insert the key into the lock and turn the key clockwise.

To close and lock the cap, push the cap down into place with the key inserted, until the lock 'clicks' into place. Withdraw the key and close the key cover.

Caution

Closing the cap without the key inserted will damage the cap, tank and lock mechanism.

General Information

Filling the Fuel Tank

Avoid filling the tank in rainy or dusty conditions where airborne material can contaminate the fuel.

Caution

Contaminated fuel may cause damage to fuel system components.

Fill the fuel tank slowly to help prevent spillage. Do not fill the tank to a level above the bottom of the filler neck. This will ensure there is enough air space to allow for fuel expansion if the fuel inside the tank expands through absorption of heat from the engine or from direct sunlight.

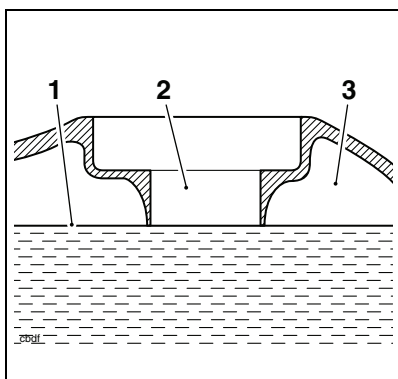

1. Maximum fuel level
2. Fuel filler neck
3. Air space

After refuelling always check that the fuel filler cap is correctly closed and locked.

Warning

Overfilling the tank can lead to fuel spillage.

If fuel is spilled, thoroughly clean up the spillage immediately and dispose of the materials used safely.

Take care not to spill any fuel on the engine, exhaust pipes, tyres or any other part of the motorcycle.

Because fuel is highly flammable, any fuel leak or spillage, or any failure to observe the safety advice given above may lead to a fire hazard, which could cause damage to property and injury or death to persons.

Fuel spilled near to, or onto the tyres will reduce the tyre's ability to grip the road. This will result in a dangerous riding condition potentially causing loss of motorcycle control and an accident.

General Information

Stands

Side Stand

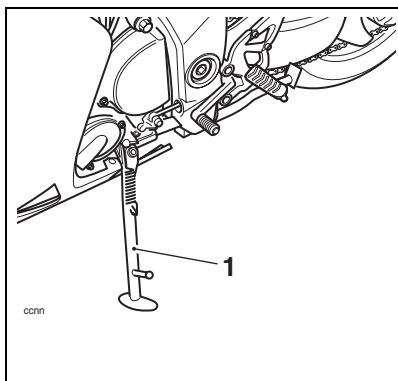

1. Side stand

The motorcycle is equipped with a side stand on which the motorcycle can be parked.

Warning

The motorcycle is fitted with an interlock system to prevent it from being ridden with the side stand in the down position.

Never attempt to ride with the side stand down or interfere with the interlock mechanism as this will cause a dangerous riding condition leading to loss of motorcycle control and an accident.

Note:

- **When using the side stand, always turn the handlebars fully to the left and leave the motorcycle in first gear.**

Whenever the side stand is used before riding, always ensure that the stand is fully up after first sitting on the motorcycle.

For instructions on safe parking, refer to the 'How to Ride the Motorcycle' section.

Centre Stand

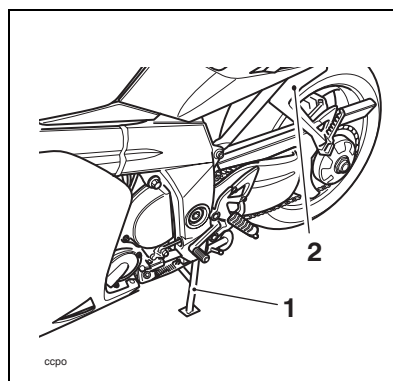

1. Centre stand

2. Lifting handle (Sprint ST shown, Sprint GT similar)

To set the motorcycle up on the centre stand, step down firmly on the foot-finder part of the stand, then lift the motorcycle up and to the rear using the lifting handle as a handhold.

For instructions on safe parking, refer to the 'How to Ride the Motorcycle' section.

General Information

Lifting Handle

The lifting handle is located on the left hand side of the motorcycle, and is the upper edge of the pillion footrest hanger.

Always use the lifting handle or grab rail to park the motorcycle on the centre stand.

Warning

Do not use the side panel or seat as a hand-hold when placing the motorcycle on the centre stand as this will cause damage.

Tool Kit and Handbook

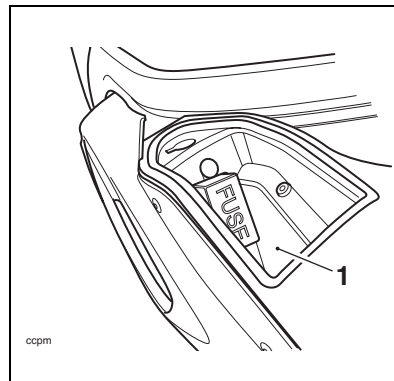

1. Tool kit/Handbook location (Sprint ST shown)

The tool kit and handbook are located in a lockable stowage box on the right hand side of the motorcycle.

To gain access, insert the ignition key into the lock and remove the cover.

Note:

- **The stowage box is not waterproof.**

General Information

Seat - Sprint ST

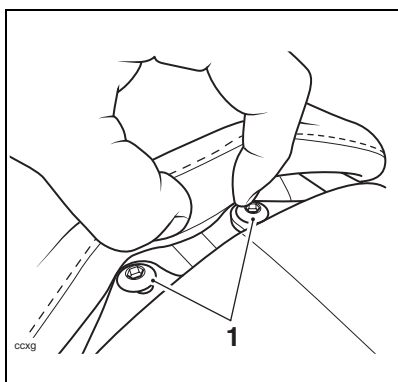

1. Seat fasteners

Two seat fixings are located under the rear edge of the seat. To remove the seat, push back the rear edge of the seat and unscrew the exposed fixings. Remove the fixings and collect the two flanged washers. Raise the seat and slide rearwards for complete removal from the motorcycle.

Warning

The silencer heat shield is located directly below the seat and may be hot to the touch. Do not touch the heat shield as contact with the hot heat shield may cause the skin to become burned.

To refit the seat, engage the seat's tongues under the fuel tank and slide the seat forwards to engage.

Refit the flanged washers and fixings.

Tighten the seat fixings to **3 Nm**.

Seat - Sprint GT

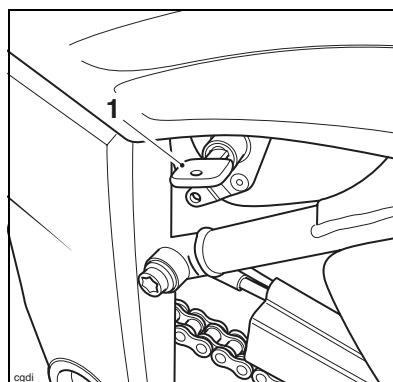

1. Seat lock

The seat lock is located on the left hand side of the battery tray, in line with the footrest mounting rail. To remove the seat, insert the ignition key into the seat lock and turn it anti-clockwise while pressing down on the rear of the seat. This will release the seat from its lock and allow it to be slid rearwards for complete removal from the motorcycle.

To refit the seat, engage the seat's two front hooks under the fuel tank, engage the centre hooks under the rear subframe bridge and slide the seat fully forwards. Press down at the rear to engage in the seat lock.

Warning

To prevent detachment of the seat during riding, after fitting always grasp the seat and pull firmly upwards. If the seat is not correctly secured, it will detach from the lock. A loose or detached seat could cause loss of motorcycle control and an accident.

General Information

Seat Care

To prevent damage to the seat or seat cover, care must be taken not to drop or lean the seat against any surface which may damage the seat or seat cover.

Caution

To prevent damage to the seat or seat cover, care must be taken not to drop the seat. Do not lean the seat against the motorcycle or any surface which may damage the seat or seat cover. Instead, place the seat, with the seat cover facing upwards, on a clean, flat surface which is covered with a soft cloth.

Do not place any item on the seat which may cause damage or staining to the seat cover.

Helmet Hooks - Sprint GT

Two helmets can be secured to the motorcycle using the helmet hooks beneath the seat.

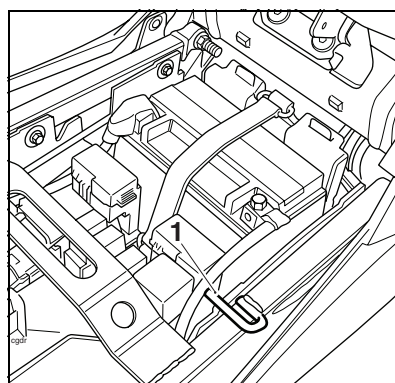

1. Helmet hooks (right hand shown)

To attach a helmet to the motorcycle, remove the seat and loop the helmet chin strap over the hook. To secure the helmet, re-fit the seat and lock into position.

Warning

Never ride the motorcycle with helmet(s) secured to the helmet hooks. Riding the motorcycle with helmet(s) secured to the helmet hooks may cause the motorcycle to become unstable leading to loss of control and an accident.

Caution

Do not allow helmets to rest against a hot silencer. The helmet may be damaged.

General Information

Triumph Accessory D-lock Storage - Sprint GT models only

Space is provided under the seat to store a Triumph accessory D-lock (available from your Triumph dealer).

Secure the lock as follows:

Thread the strap through the rear mudguard lock support from the rear, so that the buckle faces towards the rear of the motorcycle.

Position the U-section of the lock to the rear mudguard support features, ensuring the open end faces towards the rear of the motorcycle.

Position the lock body to the support on the rear mudguard.

Thread the strap over the lock and through the buckle, and pull tight, fastening the hook and loop part of the strap to secure.

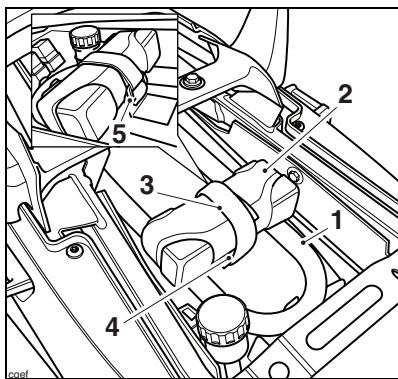

1. Lock U-section
2. Lock
3. Hook and loop strap
4. Rear mudguard lock support feature
5. Buckle

Pannier System - Sprint GT

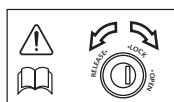

To install each pannier:

Note:

- The same procedure can be followed to remove and mount the left hand or the right hand panniers.
- The pannier is marked in three positions around the lock barrel. To lock, open or release the panniers, the key slot must align with the corresponding symbols around the barrel as shown.

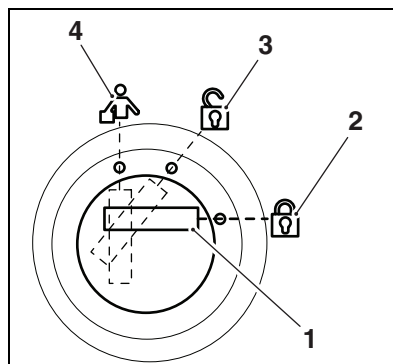

1. Key slot (shown in the LOCK position)
2. Lock position symbol
3. Unlock position symbol
4. Release position symbol

General Information

Insert the key into the lock. Turn the key to the RELEASE position and lift the carrying handle to its fully raised position.

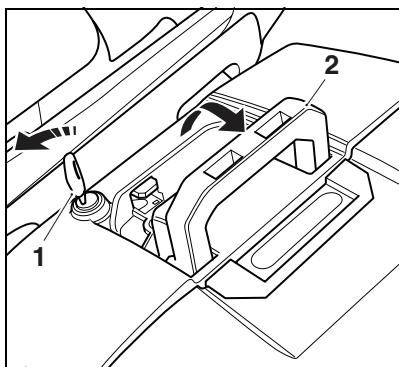

- 1. Lock**
- 2. Carrying handle**

Position the pannier to the motorcycle and engage the fixed hooks of the pannier with the pannier mounting points.

Ensure that the lower mounting bracket fits into the locating cup moulded into the front of the pannier.

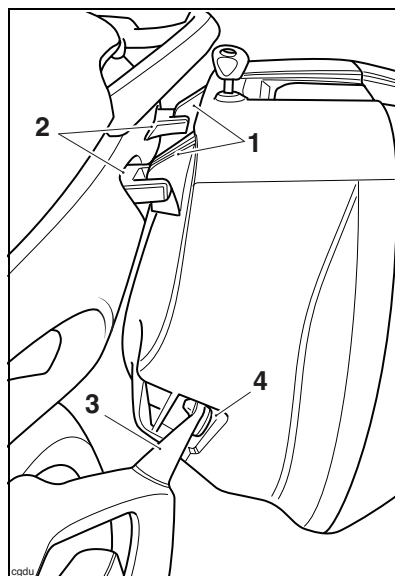

- 1. Pannier fixed hooks**
- 2. Pannier mountings**
- 3. Locating bracket**
- 4. Locating cup**

Lock the pannier to the rail by pressing the carrying handle to the fully closed position whilst turning the key to the LOCK position. Remove the key.

General Information

To remove each pannier:

Note:

- The same procedure can be followed to remove and mount the left hand or the right hand panniers.

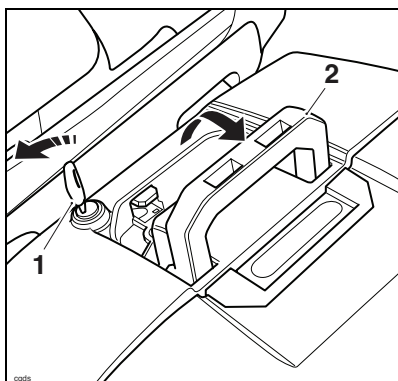

1. Lock
2. Carrying handle

To unlock and remove the pannier from the pannier mountings, turn the key to the RELEASE position and lift the carrying handle to its fully raised position. Lift the pannier free from the pannier mountings.

Pannier Operation

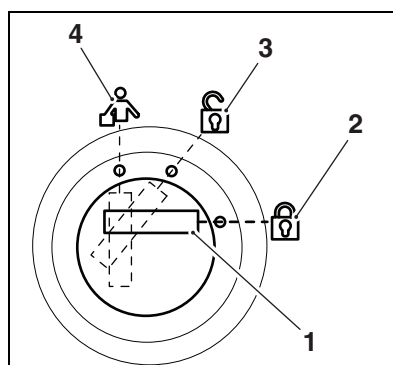

1. Key slot (shown in the LOCK position)
2. Lock position symbol
3. Unlock position symbol
4. Release position symbol

To unlock and open the pannier, insert the key and turn it to the UNLOCK position, then press down on the latch plate. The lid can then be opened.

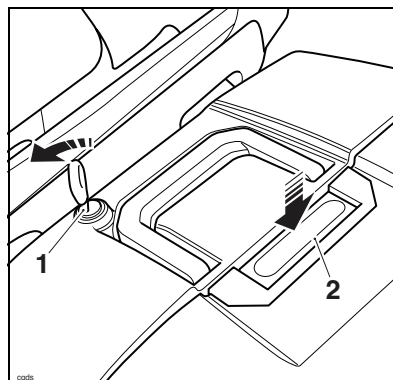

1. Lock
2. Latch plate

General Information

Caution

The pannier lid has two latch positions; the first latch position acts as a safety catch. Always ensure the pannier lid is fully closed on to the second latch position, as the pannier will not fully seal on the first latch position. Riding the motorcycle with the pannier lid in this position may allow water or dust ingress into the pannier, causing damage to the pannier contents.

Note:

- **Due to the effective nature of the pannier lid seal, reasonable force may be required to close the lid to the second latch position.**

To close and lock the pannier, close the lid until the second 'click' is heard. Turn the key to the LOCK position and remove it.

Warning

The maximum safe load for each pannier is 7.5 kg (16.5 lbs). Never exceed this loading limit as this may cause the motorcycle to become unstable leading to loss of control and an accident.

Warning

The two panniers fitted to this motorcycle are designed to be fitted as a pair. Never ride the motorcycle with only one pannier installed. Riding the motorcycle with one pannier installed may cause the motorcycle to become unstable leading to loss of control and an accident.

Warning

The two panniers fitted to this motorcycle are linked by a factory-adjusted link bar to enhance stability. This link bar allows a small amount of sideways pannier movement, independently of the motorcycle.

Do not remove or adjust the link bar as motorcycle stability will be affected. Riding the motorcycle with the link bar removed or incorrectly adjusted may cause the motorcycle to become unstable leading to loss of control and an accident.

Warning

Incorrect loading may result in an unsafe riding condition leading to an accident.

Always ensure any loads carried are evenly distributed on both sides of the motorcycle. Ensure that the load is correctly secured such that it will not move around while the motorcycle is in motion.

Always check the load security regularly (though not while the motorcycle is in motion) and ensure that the load does not extend beyond the rear of the motorcycle. Never exceed the maximum vehicle loading weight of:

- Sprint ST - 215 kg (473 lbs);
- Sprint GT - 215 kg (473 lbs).

This maximum loading weight is made up from the combined weight of the rider, passenger, any accessories fitted and any load carried.

General Information

Warning

After fitting or removing the panniers, operate the motorcycle in a safe area free from traffic to gain familiarity with the new handling characteristics. Operation when not familiar with the new characteristics of the motorcycle may result in loss of control and an accident.

Warning

This motorcycle must not be operated above the legal road speed limit except in authorised closed-course conditions.

Warning

Only operate this Triumph motorcycle at high speed in closed-course on-road competition or on closed-course racetracks. High-speed operation should only be attempted by riders who have been instructed in the techniques necessary for high-speed riding and are familiar with the motorcycle's characteristics in all conditions.

High-speed operation in any other circumstances is dangerous and will lead to loss of motorcycle control and an accident.

Warning

Never ride an accessory equipped motorcycle, or a motorcycle carrying a payload of any kind, at speeds above 80 mph (130 km/h). In either/both of these conditions, speeds in excess of 80 mph (130 km/h) should not be attempted even where the legal speed limit permits this.

The presence of accessories and/or payload will cause changes in the stability and handling of the motorcycle.

Failure to allow for changes in motorcycle stability may lead to loss of control or an accident. Remember that the 80 mph (130 km/h) absolute limit will reduce by the fitting of non-approved accessories, incorrect loading, worn tyres, overall motorcycle condition and poor road or weather conditions.

General Information

Electrical Accessory Socket

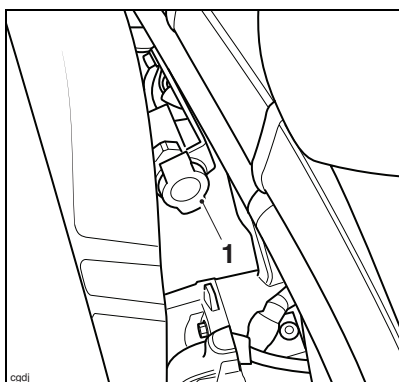

1. Electrical accessory socket

An electrical accessory socket is provided on the left hand side of the motorcycle.

The socket will provide a 12 Volt electrical supply. The socket is protected by a 10 Amp fuse therefore items with a current draw greater than 10 amps must not be plugged into the socket.

A plug, suitable for use with the accessory socket, is available from your authorised Triumph dealer.

Running-In



Running-in is the name given to the process that occurs during the first hours of a new vehicle's operation.

In particular, internal friction in the engine will be higher when components are new. Later on, when continued operation of the engine has ensured that the components have 'bedded in', this internal friction will be greatly reduced.

A period of careful running-in will ensure lower exhaust emissions, and will optimise performance, fuel economy and longevity of the engine and other motorcycle components.

During the first 500 miles (800 kilometres):

- Do not use full throttle.
- Avoid high engine speeds at all times.
- Avoid riding at one constant engine speed, whether fast or slow, for a long period of time.
- Avoid aggressive starts, stops, and rapid accelerations, except in an emergency.
- Do not ride at speeds greater than 3/4 of maximum engine speed.

General Information

From 500 to 1000 miles (800 to 1500 kilometres):

- Engine speed can gradually be increased to the rev limit for short periods.

Both during and after running-in has been completed:

- Do not over-rev the engine when cold.
- Do not let the engine labour. Always downshift before the engine begins to 'struggle'.
- Do not ride with engine speeds unnecessarily high. Changing up a gear helps reduce fuel consumption, reduces noise and helps to protect the environment.

Safe Operation

Daily Safety Checks



Check the following items each day before you ride. The time required is minimal, and these checks will help ensure a safe, reliable ride.

If any irregularities are found during these checks, refer to the Maintenance and Adjustment section or see your authorised Triumph dealer for the action required to return the motorcycle to a safe operating condition.

Warning

Failure to perform these checks every day before you ride may result in serious motorcycle damage or an accident causing serious injury or death.

Check:

Fuel: Adequate supply in tank, no fuel leaks (page 34).

Engine Oil: Correct level on dipstick. Add correct specification oil as required. No leaks from the engine or oil cooler (page 71).

Drive Chain: Check drive chain for correct adjustment and lubrication (page 81).

Tyres/Wheels: Correct inflation pressures (when cold). Tread depth/wear, tyre/wheel damage, punctures etc. (page 95).

General Information

Nuts, Bolts, Fasteners: Visually check that steering and suspension components, axles, and all controls are properly tightened or fastened. Inspect all areas for loose/damaged fixings.

Steering Action: Smooth but not loose from lock to lock. No binding of any of the control cables (page 90).

Brakes: Pull the brake lever and push the brake pedal to check for correct resistance. Investigate any lever/pedal where the travel is excessive before meeting resistance, or if either control feels spongy in operation (page 84).

On models fitted with ABS: Ensure that the ABS warning light does not remain illuminated at speeds above 6 mph (10 km/h) when moving off (page 53).

Brake Pads: There should be more than 1.5 mm of friction material remaining on all the pads (page 84).

Brake Fluid Levels: No brake fluid leakage. Brake fluid levels must be between the MAX and MIN marks on both reservoirs (page 87).

Front Forks: Smooth action. No leaks from fork seals (page 91).

Throttle: Throttle grip free play 2-3 mm. Ensure that the throttle grip returns to the idle position without sticking (page 78).

Clutch: Smooth operation and correct cable free play (page 80).

Coolant: No coolant leakage. Check the coolant level in the expansion tank (when the engine is cold) (page 75).

Electrical Equipment: All lights and horn function correctly (page 33).

Engine Stop: Stop switch turns the engine off (page 50).

Stands: Return to the fully up position by spring tension. Return springs not weak or damaged (page 37).

How to Ride the Motorcycle

HOW TO RIDE THE MOTORCYCLE

Table of Contents

To Stop the Engine.....	50
To Start the Engine.....	50
Moving Off.....	51
Changing Gears.....	52
Braking.....	53
ABS (Anti-Lock Brake System) - Sprint GT only.....	55
Parking.....	56
Considerations for High-Speed Operation.....	58
General.....	58
Steering.....	58
Luggage.....	58
Brakes.....	59
Tyres.....	59
Fuel.....	59
Engine Oil.....	59
Coolant.....	59
Electrical Equipment.....	59
Miscellaneous.....	59

How to Ride the Motorcycle

To Stop the Engine

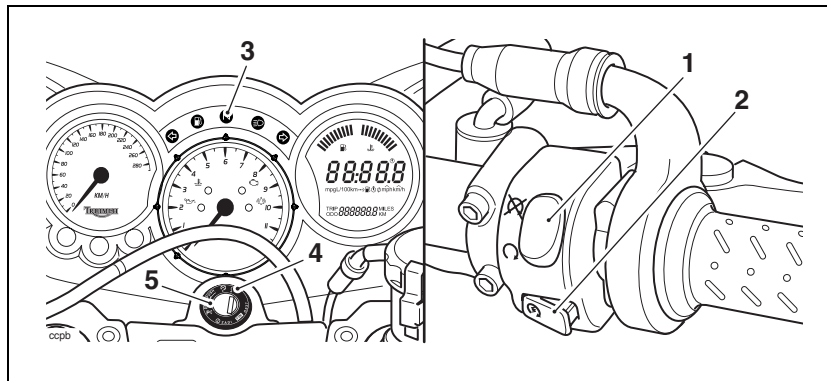

1. Engine stop switch
2. Starter button
3. Neutral indicator light
4. ON position
5. Ignition switch

Close the throttle completely.

Select neutral.

Turn the ignition switch off.

Select first gear.

Support the motorcycle on a firm, level surface with the side or centre stand.

Lock the steering.

Caution

The engine should normally be stopped by turning the ignition switch to the OFF position. The engine stop switch is for emergency use only. Do not leave the ignition switched on with the engine stopped. Electrical damage may result.

To Start the Engine

Check that the engine stop switch is in the RUN position.

Ensure the transmission is in neutral.

Turn the ignition switch on.

Note:

- **When the ignition is switched on, the tachometer and speedometer needles will quickly sweep from zero to maximum and then return to zero. The instrument warning lights will illuminate and will then go off (except those which normally remain on until the engine starts - see page 27). It is not necessary to wait for the needle to return to zero before starting the engine.**
- **In very cold conditions, part open the throttle to aid cold starting. Return to the closed position once the engine has started.**

How to Ride the Motorcycle

Pull the clutch lever fully into the handlebar. Leaving the throttle fully closed, push the starter button until the engine starts.

Warning

Never start the engine or run the engine in a confined area. Exhaust fumes are poisonous and can cause loss of consciousness and death within a short period of time. Always operate your motorcycle in the open-air or in an area with adequate ventilation.

Caution

Do not operate the starter continuously for more than 5 seconds as the starter motor will overheat and the battery will become discharged. Wait 15 seconds between each operation of the starter to allow for cooling and recovery of battery power.

Do not let the engine idle for long periods as this may lead to overheating which will cause damage to the engine.

Caution

The low oil pressure warning light should go out shortly after the engine starts.

If the low oil pressure warning light stays on after starting the engine, stop the engine immediately and investigate the cause. Running the engine with low oil pressure will cause severe engine damage.

- The motorcycle is equipped with starter lockout switches. The switches prevent the electric starter from operating when the transmission is not in neutral with the side stand down.
- If the side stand is extended whilst the engine is running, and the transmission is not in neutral then the engine will stop regardless of clutch position.

Moving Off

Pull in the clutch lever and select first gear. Open the throttle a little and let out the clutch lever slowly. As the clutch starts to engage, open the throttle a little more, allowing enough engine speed to avoid stalling.

How to Ride the Motorcycle

Changing Gears

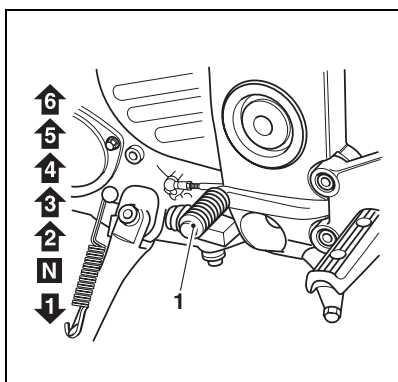

1. Gear change pedal



Close the throttle while pulling in the clutch lever. Change into the next higher or lower gear. Open the throttle part way, while releasing the clutch lever. Always use the clutch when changing gear.

Warning

Take care to avoid opening the throttle too far or too fast in any of the lower gears as this can lead to the front wheel lifting from the ground (pulling a 'wheelie') and to the rear tyre breaking traction (wheel spin).

Always open the throttle cautiously, particularly if you are unfamiliar with the motorcycle, as a 'wheelie' or loss of traction will cause loss of motorcycle control and an accident.

Note:

- The gear change mechanism is the 'positive stop' type. This means that, for each movement of the gear change pedal, you can only select each gear, one after the other, in ascending or descending order.

Warning

Do not change to a lower gear at speeds that will cause excessive engine rpm (r/min). This can lock the rear wheel causing loss of control and an accident. Engine damage may also be caused. Changing down should be done such that low engine speeds will be ensured.

How to Ride the Motorcycle

Braking

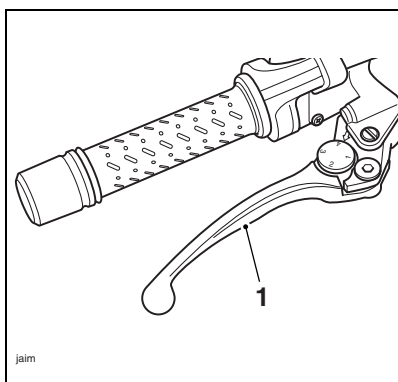

1. Front brake lever

Warning

WHEN BRAKING, OBSERVE THE FOLLOWING:

Close the throttle completely, leaving the clutch engaged to allow the engine to help slow down the motorcycle.

Change down one gear at a time such that the transmission is in first gear when the motorcycle comes to a complete stop.

When stopping, always apply both brakes at the same time. Normally the front brake should be applied a little more than the rear.

Change down or fully disengage the clutch as necessary to keep the engine from stalling.

Never lock the brakes, as this may cause loss of control of the motorcycle and an accident.

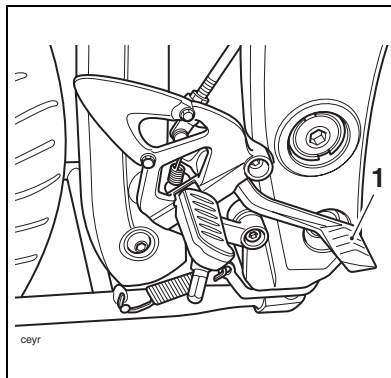

1. Rear brake pedal

Warning

For emergency braking, disregard down changing, and concentrate on applying the front and rear brakes as hard as possible without skidding. Riders should practice emergency braking in a traffic-free area. (See ABS warnings below/over.)

Triumph strongly recommends that all riders take a course of instruction, which includes advice on safe brake operation. Incorrect brake technique could result in loss of control and an accident.

How to Ride the Motorcycle

Warning

For your safety, always exercise extreme caution when braking, (whether or not ABS is fitted), accelerating or turning as any incautious action can cause loss of control and an accident. Independent use of the front or rear brakes reduces overall braking performance. Extreme braking may cause either wheel to lock, reducing control of the motorcycle and causing an accident (see ABS warnings below).

When possible, reduce speed or brake before entering a turn as closing the throttle or braking in mid-turn may cause wheel slip leading to loss of control and an accident.

When riding in wet or rainy conditions, or on loose surfaces, the ability to manoeuvre and stop will be reduced. All of your actions should be smooth under these conditions. Sudden acceleration, braking or turning may cause loss of control and an accident.

Warning

When descending a long, steep gradient, use engine braking by down changing and use the brakes intermittently. Continuous brake application can overheat the brakes and reduce their effectiveness.

Riding with your foot on the brake pedal or your hands on the brake lever may actuate the brake light, giving a false indication to other road users. It may also overheat the brake, reducing braking effectiveness.

Do not coast with the engine switched off, and do not tow the motorcycle. The transmission is pressure-lubricated only when the engine is running. Inadequate lubrication may cause damage or seizure of the transmission, which can lead to sudden loss of motorcycle control and an accident.

How to Ride the Motorcycle

ABS (Anti-Lock Brake System) - Sprint GT only

Warning

Where fitted, ABS prevents the wheels from locking, therefore maximising the effectiveness of the braking system in emergencies and when riding on slippery surfaces. The potentially shorter braking distances ABS allows under certain conditions are not a substitute for good riding practice.

Always ride within the legal speed limit.

Never ride without due care and attention and always reduce speed in consideration of weather, road and traffic conditions.

Take care when cornering. If the brakes are applied in a corner, ABS will not be able to counteract the weight and momentum of the motorcycle. This can result in loss of control and an accident.

Under some circumstances it is possible that a motorcycle equipped with ABS may require a longer stopping distance than an equivalent motorcycle without ABS.

ABS Warning Light



The ABS indicator light illuminates to show that the ABS function is not available. Illumination is normal after engine start-up, and until the motorcycle first reaches a speed exceeding 6 mph (10 km/h). Unless there is a fault, it should not illuminate again until the engine is restarted.

If the indicator light becomes illuminated at any other time while riding, it indicates that the ABS has a malfunction that requires investigation.

Note:

- **Normally, the rider will perceive ABS operation as a harder feel or a pulsation of the brake lever and pedal. As the ABS is not an integrated braking system and it does not control both the front and rear brake at the same time, this pulsation may be felt in the lever, the pedal or both.**
- **The ABS may be activated by sudden upward or downward changes in the road surface.**

Warning

If the ABS is not functioning, the brake system will continue to function as a non-ABS braking system. Do not continue to ride for longer than is necessary with the indicator light illuminated. Contact an authorised Triumph dealer as soon as possible to have the fault checked and rectified. In this situation, braking too hard will cause the wheels to lock resulting in loss of control and an accident.

How to Ride the Motorcycle

Warning

The ABS warning light will illuminate when the rear wheel is driven at high speed for more than 30 seconds when the motorcycle is on a stand. This reaction is normal.

When the ignition is switched off and the motorcycle is re-started, the warning light will illuminate until the motorcycle reaches a speed exceeding 19 mph (30 km/h).

Warning

The ABS computer operates by comparing the relative speed of the front and rear wheels. Use of non-recommended tyres can affect wheel speed and cause the ABS function not to operate, potentially leading to loss of control and an accident in conditions where the ABS would normally function.

Parking

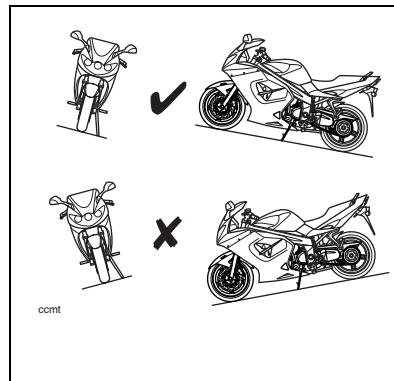

Select neutral and turn the ignition switch to the OFF position.

Lock the steering to help prevent theft.

Always park on a firm, level surface to prevent the motorcycle from falling.

When parking on a hill, always park facing uphill to prevent the motorcycle from rolling off the stand. Engage first gear to prevent the motorcycle from moving.

On a lateral (sideways) incline, always park such that the incline naturally pushes the motorcycle towards the side stand.

Do not park on a lateral (sideways) incline of greater than 6° and never park facing downhill.

How to Ride the Motorcycle

Note:

- **When parking near traffic at night, or when parking in a location where parking lights are required by law, leave the tail, licence plate and position lights on by turning the ignition switch to P (Park).**

Do not leave the switch in the P position for long periods of time as this will discharge the battery.

Ensure that the side stand is fully retracted before riding off.

 **Warning**

Do not park on a soft or on a steeply inclined surface. Parking under these conditions may cause the motorcycle to fall over causing damage to property and personal injury.

 **Warning**

Petrol is extremely flammable and can be explosive under certain conditions. If parking inside a garage or other structure, be sure it is well ventilated and the motorcycle is not close to any source of flame or sparks. This includes any appliance with a pilot light.

Failure to follow the above advice may cause a fire resulting in damage to property or personal injury.

 **Warning**

The engine and exhaust system will be hot after riding. DO NOT park where pedestrians and children are likely to touch the motorcycle.

Touching any part of the engine or exhaust system when hot may cause unprotected skin to become burnt.

How to Ride the Motorcycle

Considerations for High-Speed Operation

Warning

This Triumph motorcycle should be operated within the legal speed limits for the particular road travelled. Operating a motorcycle at high speeds can be potentially dangerous since the time available to react to given traffic situations is greatly reduced as road speed increases. Always reduce speed in consideration of weather and traffic conditions.

Warning

Only operate this Triumph motorcycle at high speed in closed-course on-road competition or on closed-course racetracks. High-speed operation should only then be attempted by riders who have been instructed in the techniques necessary for high-speed riding and are familiar with the motorcycle's characteristics in all conditions.

High-speed operation in any other circumstances is dangerous and will lead to loss of motorcycle control and an accident.

Warning

The handling characteristics of a motorcycle at high speed may vary from those you are familiar with at legal road speeds. Do not attempt high-speed operation unless you have received sufficient training and have the required skills as a serious accident may result from incorrect operation.

Warning

The items listed are extremely important and must never be neglected. A problem, which may not be noticed at normal operating speeds, may be greatly exaggerated at high speeds.

General

Ensure the motorcycle has been maintained according to the scheduled maintenance chart.

Steering

Check that the handlebar turns smoothly without excessive free play or tight spots. Ensure that the control cables do not restrict the steering in any way.

Luggage

Make certain that any luggage containers are closed, locked and securely fitted to the motorcycle.

Ensure panniers are evenly loaded.

Ensure the motorcycle is not overloaded.

How to Ride the Motorcycle

Brakes

Check that the front and rear brakes are functioning properly.

On models fitted with ABS, check that the system is functioning by ensuring that the ABS indicator light does not remain illuminated at speeds above 6 mph (10 km/h).

Tyres

High-speed operation is hard on tyres, and tyres that are in good condition are crucial to riding safely. Examine their overall condition, inflate to the correct pressure (when the tyres are cold), and check the wheel balance. Securely fit the valve caps after checking tyre pressures. Observe the information given in the Maintenance and Specification sections on tyre checking and tyre safety.

Fuel

Have sufficient fuel for the increased fuel consumption that will result from high-speed operation.

Engine Oil

Make certain that the engine oil level is correct. Ensure that the correct grade and type of oil is used when topping up.

Coolant

Check that the coolant level is at the upper level line in the expansion tank. (Always check the level with the engine cold.)

Electrical Equipment

Make certain that the headlight, rear/brake light, direction indicators, horn, etc. all work properly.

Miscellaneous

Visually check that all fixings are tight.

Caution

In all countries except Australia, Hong Kong, New Zealand and South Africa, the exhaust system for this model is fitted with a catalytic converter to help reduce exhaust emission levels. The catalytic converter can be permanently damaged if the motorcycle is allowed to run out of fuel or if the fuel level is allowed to get very low. Always ensure you have adequate fuel for your journey.

How to Ride the Motorcycle

This page intentionally left blank

Accessories and Loading

ACCESSORIES AND LOADING

The addition of accessories and carriage of additional weight can affect the motorcycle's handling characteristics causing changes in stability and necessitating a reduction in speed. The following information has been prepared as a guide to the potential hazards of adding accessories to a motorcycle and carrying passengers and additional loads.

Warning

Incorrect loading may result in an unsafe riding condition leading to an accident.

Always ensure any loads carried are evenly distributed on both sides of the motorcycle. Ensure that the load is correctly secured such that it will not move around while the motorcycle is in motion.

Always check the load security regularly (though not while the motorcycle is in motion) and ensure that the load does not extend beyond the rear of the motorcycle.

Never exceed the maximum vehicle loading weight of:

- Sprint ST - 215 kg (473 lbs);
- Sprint GT - 215 kg (473 lbs).

This maximum loading weight is made up from the combined weight of the rider, passenger, any accessories fitted and any load carried.

Warning

Do not install accessories or carry luggage that impairs the control of the motorcycle.

Make sure that you have not adversely affected the visibility of any lighting component, road clearance, banking capability (i.e. lean angle), control operation, wheel travel, ABS where fitted, front fork movement, visibility in any direction, or any other aspect of the motorcycle's operation.

Accessories and Loading

Warning

Never ride an accessory equipped motorcycle, or a motorcycle carrying a payload of any kind, at speeds above 80 mph (130 km/h). In either/both of these conditions, speeds in excess of 80 mph (130 km/h) should not be attempted even where the legal speed limit permits this.

The presence of accessories and/or payload will cause changes in the stability and handling of the motorcycle.

Failure to allow for changes in motorcycle stability may lead to loss of control or an accident. Remember that the 80 mph (130 km/h) absolute limit will reduce by the fitting of non-approved accessories, incorrect loading, worn tyres, overall motorcycle condition and poor road or weather conditions.

Warning

This motorcycle must not be operated above the legal road speed limit except in authorised closed-course conditions.

Warning

Only operate this Triumph motorcycle at high speed in closed-course on-road competition or on closed-course racetracks. High-speed operation should only then be attempted by riders who have been instructed in the techniques necessary for high-speed riding and are familiar with the motorcycle's characteristics in all conditions.

High-speed operation in any other circumstances is dangerous and will lead to loss of motorcycle control and an accident.

Warning

Your passenger should be instructed that he or she can cause loss of motorcycle control by making sudden movements or by adopting an incorrect seated position.

The rider should instruct the passenger as follows:

- It is important that the passenger sits still while the motorcycle is in motion and does not interfere with the operation of the motorcycle.
- To keep his or her feet on the passenger footrests and to firmly hold onto the seat strap or the rider's waist or hips.
- Advise the passenger to lean with the rider when travelling around corners and not to lean unless the rider does so.

Accessories and Loading

Warning

Do not carry animals on your motorcycle. An animal could make sudden and unpredictable movements that could lead to loss of motorcycle control and an accident.

Warning

The handling and braking capabilities of a motorcycle will be affected by the presence of a passenger. The rider must make allowances for these changes when operating the motorcycle with a passenger and should not attempt such operation unless trained to do so and without becoming familiar and comfortable with the changes in motorcycle operating characteristics that this brings about.

Motorcycle operation without making allowances for the presence of a passenger could lead to loss of motorcycle control and an accident.

Warning

Never attempt to store any items between the frame and the fuel tank. This can restrict the steering and will cause loss of control leading to an accident.

Weight attached to the handlebar or front fork will increase the mass of the steering assembly and can result in loss of steering control leading to an accident.

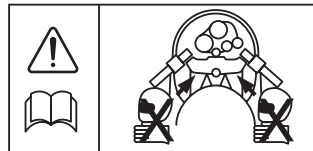

Warning

Do not carry a passenger unless he or she is tall enough to reach the footrests provided.

A passenger who is not tall enough to reach the footrests will be unable to sit securely on the motorcycle and may cause instability leading to loss of control and an accident.

Accessories and Loading

Warning

If the passenger seat or rack (rack on Sprint GT models) are used to carry small objects, they must not exceed a total maximum of 5 kg in weight (combined on the seat and rack on Sprint GT models), must not impair control of the motorcycle, must be securely attached and must not extend beyond the rear or sides of the motorcycle.

Carriage of objects in excess of 5 kg in weight, that are insecure, impair control or extend beyond the rear or sides of the motorcycle may lead to loss of motorcycle control and an accident.

Even if small objects are correctly loaded onto the rear seat or rack (on Sprint GT models), the maximum speed of the motorcycle must be reduced to 80 mph (130 km/h).

Caution

Sprint ST only: Do not allow luggage to rest on or against the upper portion of the rear bodywork.

Allowing luggage to rest on or against the upper portion of the rear bodywork could close the air gap between the bodywork and the exhaust potentially causing the bodywork to become damaged by overheating.

Maintenance and Adjustment

MAINTENANCE AND ADJUSTMENT

Table of Contents

Scheduled Maintenance	68
Engine Oil	71
Oil Level Inspection	71
Oil and Oil Filter Change	73
Oil Specification and Grade	74
Disposal of Used Engine Oil and Oil Filters	74
Cooling System	75
Corrosion Inhibitors	75
Coolant Level Inspection	76
Coolant Level Adjustment	76
Coolant Change	77
Radiator and Hoses	77
Throttle Control	78
Inspection	78
Adjustment	79
Clutch	80
Inspection	80
Adjustment	80
Drive Chain	81
Chain Lubrication	81
Chain Free-Movement Inspection	82
Chain Free-Movement Adjustment	82
Chain and Sprocket Wear Inspection	83
Brakes	84
Brake Wear Inspection	84
Breaking-in New Brake Pads and Discs	85
Brake Pad Wear Compensation	85
Disc Brake Fluid	86
Brake Fluid Level Inspection and Adjustment	87
Brake Light Switches	89

Maintenance and Adjustment

Steering/Wheel Bearings	90
Steering Inspection	90
Inspecting the Steering (Headstock) Bearings for Free Play	90
Wheel Bearings Inspection	91
Front Suspension	91
Front Fork Inspection	91
Suspension Setting Chart	92
Front Suspension Settings	92
Spring Pre-Load Adjustment	93
Rear Suspension Adjustment	93
Rebound Damping Adjustment	93
Spring Pre-Load Adjustment - Sprint ST	94
Tyres	95
Tyre Inflation Pressures	95
Tyre Wear	96
Minimum Recommended Tread Depth	96
Tyre Replacement	97
Battery	99
Battery Removal	99
Battery Disposal	100
Battery Maintenance	100
Battery Discharge	100
Battery Discharge During Storage and Infrequent Use of the Motorcycle	101
Battery Charging	101
Battery Installation	102
Fuse Box	102
Fuse Identification - Sprint ST	103
Fuse Identification - Sprint GT	104
Headlights	105
Headlight Adjustment	106
Main Beam Horizontal Adjustment	106
Main Beam Vertical Adjustment	106
Dipped Headlight Vertical Adjustment	107
Dipped Headlight Horizontal Adjustment	107
Dipped Headlight Bulb Replacement	108

Maintenance and Adjustment

Main Beam Bulb Replacement	108
Position Lamp Bulb Replacement	109
Rear Light	109
Direction Indicator Lights	110
Front Indicator Bulb Replacement	110
Rear Indicator Bulb Replacement	110
Licence Plate Light	111
Bulb Replacement	111
Windscreen Cleaning	111
Cleaning	112
Preparation for Washing	112
Where to be Careful	113
After Washing	113
Seat Care	113
Unpainted Aluminium Items	114
Cleaning of the Exhaust System	114
Washing	114
Drying	114
Protecting	114

Maintenance and Adjustment

Scheduled Maintenance

To maintain the motorcycle in a safe and reliable condition, the maintenance and adjustments outlined in this section must be carried out as specified in the schedule of daily checks, and also in line with the scheduled maintenance chart. The information that follows describes the procedures to follow when carrying out the daily checks and some simple maintenance and adjustment items.

Warning

Special tools, knowledge and training are required in order to correctly carry out the maintenance items listed in the scheduled maintenance chart. Only an authorised Triumph dealer will have this knowledge and equipment.

Since incorrect or neglected maintenance can lead to a dangerous riding condition, always have an authorised Triumph dealer carry out the scheduled maintenance of this motorcycle.

Warning

All maintenance is vitally important and must not be neglected. Incorrect maintenance or adjustment may cause one or more parts of the motorcycle to malfunction. A malfunctioning motorcycle may lead to loss of control and an accident.

Weather, terrain and geographical location affects maintenance. The maintenance schedule should be adjusted to match the particular environment in which the vehicle is used and the demands of the individual owner.

Since incorrect or neglected maintenance can lead to a dangerous riding condition, always have an authorised Triumph dealer carry out the scheduled maintenance of this motorcycle.

Triumph Motorcycles cannot accept any responsibility for damage or injury resulting from incorrect maintenance or improper adjustment carried out by the owner.

Maintenance and Adjustment

Operation Description	Odometer Reading in Miles (Kms) or Time Period, whichever comes first					
		First Service	A Service	B Service	C Service	D Service
	Every	500 (800) 1 month	6,000 (10,000) 1 year	12,000 (20,000) 2 years	18,000 (30,000) 3 years	24,000 (40,000) 4 years
Engine and oil cooler - check for leaks	Day	•	•	•	•	•
Engine oil - renew	-	•	•	•	•	•
Engine oil filter - renew	-	•	•	•	•	•
Valve clearances - check/adjust	-			•		•
Air cleaner - renew	-			•		•
Autoscan - carry out a full Autoscan using the Triumph diagnostic tool	-	•		•		•
Engine ECM - check for stored DTCs			•		•	
ABS ECM - check for stored DTCs		•	•	•	•	•
Spark plugs - check	-		•		•	
Spark plugs - renew	-			•		•
Throttle bodies - balance	-		•	•	•	•
Throttle cables - check/adjust	Day	•	•	•	•	•
Cooling system - check for leaks, chafing etc.	Day	•	•	•	•	•
Coolant level - check/adjust	Day	•	•		•	
Coolant - renew	-			•		•
Fuel system - check for leaks, chafing etc.	Day	•	•	•	•	•
Lights, instruments and electrical systems - check	Day	•	•	•	•	•
Steering - check for free operation	Day	•	•	•	•	•
Headstock bearings - check/adjust	-	•	•	•	•	•
Headstock bearings - lubricate	-			•		•
Forks - check for leaks/smooth operation	Day	•	•	•	•	•
Fork oil - renew	-					•

Maintenance and Adjustment

Operation Description	Odometer Reading in Miles (Kms) or Time Period, whichever comes first					
		First Service	A Service	B Service	C Service	D Service
	Every	500 (800) 1 month	6,000 (10,000) 1 year	12,000 (20,000) 2 years	18,000 (30,000) 3 years	24,000 (40,000) 4 years
Brake fluid levels - check	Day	•	•	•	•	•
Brake fluid - renew	Every 2 years					
Brake pads - check wear levels	Day	•	•	•	•	•
Brake calipers - check for fluid leaks and seized pistons		•	•	•	•	•
Brake master cylinders - check for fluid leaks		•	•	•	•	•
Drive chain - lubricate	Every 200 miles (300 kms)					
Drive chain - wear check	Every 500 miles (800 kms)					
Drive chain slack - check/adjust	Day	•	•	•	•	•
Drive rubbing strip - check	-		•	•	•	•
Wheel bearings - check for wear/smooth operation			•	•	•	•
Rear wheel bearing - lubricate	-			•		•
Wheels - inspect for damage	Day	•	•	•	•	•
Tyre wear/tyre damage - check	Day	•	•	•	•	•
Tyre pressures - check/adjust	Day	•	•	•	•	•
Clutch cable - check/adjust	Day	•	•	•	•	•
Stand - check operation	Day	•	•	•	•	•
Secondary air injection system - check/clean	-			•		•
Secondary exhaust to header clamp bolt - check/adjust	-	•	•	•	•	•
Fasteners - inspect visually for security	Day	•	•	•	•	•
Accessory rack sliding carriage - check for correct operation		•	•	•	•	•
Fuel and evaporative loss* hoses - renew	-					•

*Evaporative system fitted to California models only.

Maintenance and Adjustment

Engine Oil



obnz

In order for the engine, transmission, and clutch to function correctly, maintain the engine oil at the correct level, and change the oil and oil filter in accordance with scheduled maintenance requirements.

Warning

Motorcycle operation with insufficient, deteriorated, or contaminated engine oil will cause accelerated engine wear and may result in engine or transmission seizure. Seizure of the engine or transmission may lead to sudden loss of control and an accident.

Oil Level Inspection

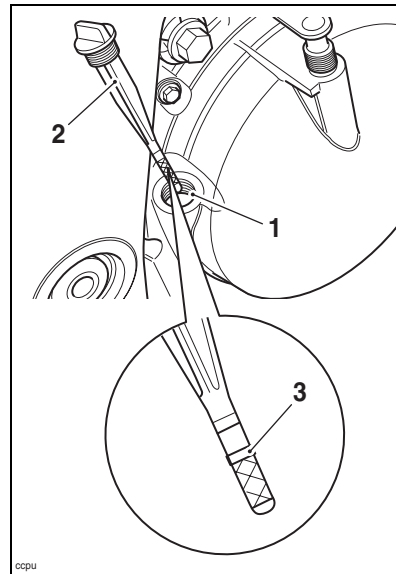

ccpu

1. Filler
2. Filler plug/Dipstick
3. Upper marking

Note:

- An accurate indication of the level of oil in the engine is only shown when the engine oil is at normal operating temperature, the motorcycle is upright (not on the side stand) and the filler plug/dipstick has been fully screwed home.

Maintenance and Adjustment

Warning

Never start the engine or run the engine in a confined area. Exhaust fumes are poisonous and can cause loss of consciousness and death within a short period of time. Always operate your motorcycle in the open-air or in an area with adequate ventilation.

Caution

Running the engine with insufficient oil will cause engine damage. If the low oil pressure indicator remains on, stop the engine immediately and investigate the cause.

Start the engine and run at idle for approximately five minutes.

Stop the engine and wait for three minutes to allow the oil to settle.

With the motorcycle upright, remove the filler plug/dipstick, wipe the blade clean and screw it fully home.

Remove the filler plug/dipstick.

The oil level is indicated by lines on the filler plug/dipstick. When full, the indicated oil level must be level with the upper marking on the dipstick.

If the oil level is below the lower marking, add oil a little at a time until the correct level is reached. Once the correct level is reached, re-fit the filler plug/dipstick.

Maintenance and Adjustment

Oil and Oil Filter Change

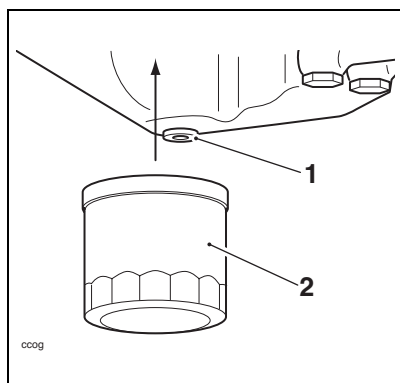

1. Oil drain plug
2. Oil filter

The engine oil and filter must be replaced in accordance with scheduled maintenance requirements.

Warning

Prolonged or repeated contact with engine oil can lead to skin dryness, irritation and dermatitis. In addition, used engine oil contains harmful contamination that can lead to skin cancer. Always wear suitable protective clothing and avoid skin contact with used oil.

Warm up the engine thoroughly, and then stop the engine and secure the motorcycle in an upright position on level ground.

Place an oil drain pan beneath the engine.

Remove the oil drain plug.

Warning

The oil may be hot to the touch. Avoid contact with the hot oil by wearing suitable protective clothing, gloves, eye protection, etc. Contact with hot oil may cause the skin to be scalded or burned.

Unscrew and remove the oil filter using Triumph service tool T3880313. Dispose of the old filter in an environmentally friendly way.

After the oil has completely drained out, fit a new sealing washer to the drain plug. Fit and tighten the drain plug to **25 Nm**.

Apply a thin smear of clean engine oil to the sealing ring of the new oil filter. Fit the oil filter and tighten to **10 Nm**.

Fill the engine to the maximum mark with a 10 W/40 or 15 W/50 semi or fully synthetic motorcycle engine oil that meets specification API SH (or higher) AND JASO MA.

Start the engine and allow it to idle for a minimum of 30 seconds.

Caution

Raising the engine speed above idle before the oil reaches all parts of the engine can cause engine damage or seizure. Only raise engine speed after running the engine for 30 seconds to allow the oil to circulate fully.

Maintenance and Adjustment

Caution

If the engine oil pressure is too low, the low oil pressure warning light will illuminate. If this light stays on when the engine is running, stop the engine immediately and investigate the cause. Running the engine with low oil pressure will cause engine damage.

Ensure that the low oil pressure warning light extinguishes shortly after starting.

Turn off the ignition, check the oil level using the method previously described, and top up to between the minimum and maximum level lines on the dipstick.

Oil Specification and Grade

Triumph high performance fuel injected engines are designed to use 10 W/40 or 15 W/50 semi or fully synthetic motorcycle engine oil that meets specification API SH (or higher) AND JASO MA.

Do not add any chemical additives to the engine oil. The engine oil also lubricates the clutch and any additives could cause the clutch to slip.

Do not use mineral, vegetable, non-detergent oil, castor based oils or any oil not conforming to the required specification. The use of these oils may cause instant, severe engine damage.

Disposal of Used Engine Oil and Oil Filters

To protect the environment, do not pour oil on the ground, down sewers or drains, or into watercourses. Do not place used oil filters in with general waste. If in doubt, contact your local authority.

Maintenance and Adjustment

Cooling System

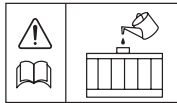

To ensure efficient engine cooling, check the coolant level each day before riding the motorcycle, and top up the coolant if the level is low.

Note:

- **A year-round, Hybrid Organic Acid Technology (known as Hybrid OAT or HOAT) coolant is installed in the cooling system when the motorcycle leaves the factory. It is coloured green, contains a 50% solution of ethylene glycol based antifreeze, and has a freezing point of -35°C (-31°F).**

Corrosion Inhibitors

To protect the cooling system from corrosion, the use of corrosion inhibitor chemicals in the coolant is essential.

If coolant containing a corrosion inhibitor is not used, the cooling system will accumulate rust and scale in the water jacket and radiator. This will block the coolant passages, and considerably reduce the efficiency of the cooling system.

Warning

HD4X Hybrid OAT coolant contains corrosion inhibitors and anti-freeze suitable for aluminium engines and radiators. Always use the coolant in accordance with the instructions of the manufacturer.

Coolant that contains anti-freeze and corrosion inhibitors contains toxic chemicals that are harmful to the human body. Never swallow anti-freeze or any of the motorcycle coolant.

Note:

- **HD4X Hybrid OAT coolant, as supplied by Triumph, is pre-mixed and does not need to be diluted prior to filling or topping up the cooling system.**

Maintenance and Adjustment

Coolant Level Inspection

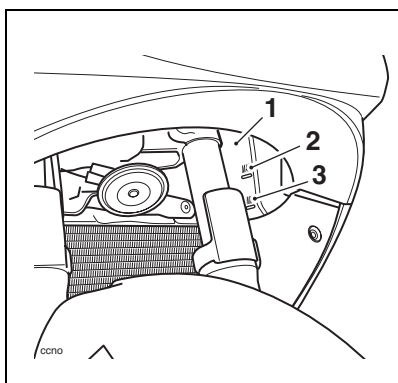

1. Expansion tank
2. MAX mark
3. MIN mark

Position the motorcycle on level ground and in an upright position. The expansion tank is located beneath removable panels on the left hand side of the front fairing.

The coolant level in the expansion tank can be checked by looking up and through the centre opening of the front fairing. The level can also be checked from above by looking down to the left.

Check the coolant level in the expansion tank. The coolant level must be between the MAX and MIN marks. If the coolant is below the minimum level, the coolant level must be adjusted.

Coolant Level Adjustment

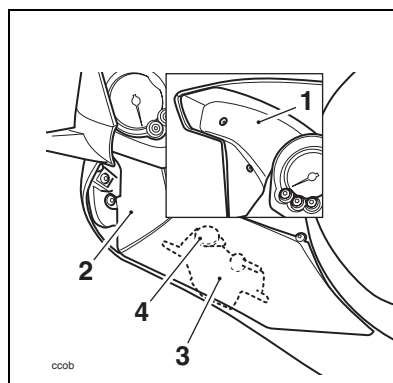

1. Upper infill panel
2. Lower infill panel
3. Expansion tank
4. Tank cap

Warning

Do not remove the expansion tank or radiator pressure cap when the engine is hot. When the engine is hot, the coolant inside the radiator will be hot and also under pressure. Contact with this hot, pressurised coolant will cause scalds and skin damage.

Allow the engine to cool.

Remove the two fixings, release the upper infill panel bayonet from the grommet and carefully remove the infill panel.

Remove the fixing and carefully remove the lower (fairing) infill panel to expose the expansion tank.

Maintenance and Adjustment

Remove the cap from the expansion tank and add coolant mixture through the filler opening until the level reaches the MAX mark. Refit the cap.

Note:

- **If the coolant level is being checked because the coolant has overheated, also check the level in the radiator and top up if necessary.**
- **In an emergency, distilled water can be added to the cooling system. However, the coolant must then be drained and replenished with HD4X Hybrid OAT coolant as soon as possible.**

 **Caution**

If hard water is used in the cooling system, it will cause scale accumulation in the engine and radiator and considerably reduce the efficiency of the cooling system. Reduced cooling system efficiency may cause the engine to overheat and suffer severe damage.

Carefully refit the infill panels, ensuring the upper infill panel bayonet fixing is secured to the lower infill panel grommet. Tighten the fixings to **5 Nm**.

Coolant Change

Have the coolant changed by an authorised Triumph dealer in accordance with scheduled maintenance requirements.

Radiator and Hoses

Check the radiator hoses for cracks or deterioration, and hose clips for tightness in accordance with scheduled maintenance requirements. Have your authorised Triumph dealer replace any defective items.

Check the radiator grille and fins for obstructions by insects, leaves or mud. Clean off any obstructions with a stream of low-pressure water.

 **Warning**

The fan operates automatically when the engine is running. Always keep hands and clothing away from the fan as contact with the rotating fan can cause injury.

 **Caution**

Using high-pressure water sprays, such as from a car wash facility or household pressure washer, can damage the radiator fins, cause leaks and impair the radiator's efficiency.

Do not obstruct or deflect airflow through the radiator by installing unauthorised accessories, either in front of the radiator or behind the cooling fan. Interference with the radiator airflow can cause overheating, potentially resulting in engine damage.

Maintenance and Adjustment

Throttle Control

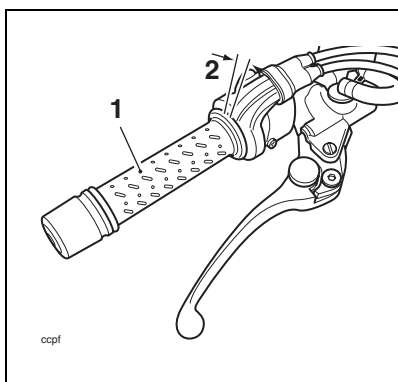

1. Throttle grip
2. 2 - 3 mm

Warning

The throttle grip controls the throttle valves in the throttle bodies. If the throttle cables are incorrectly adjusted, either too tight or too loose, the throttle may be difficult to control and performance will be adversely affected.

Check the throttle grip free play in accordance with scheduled maintenance requirements and make adjustments as necessary.

Warning

Always be alert for changes in the 'feel' of the throttle and have the throttle system checked by an authorised Triumph dealer if any changes are detected. Changes can be due to wear in the mechanism, which could lead to a sticking throttle.

An incorrectly adjusted, sticking or stuck throttle will lead to loss of motorcycle control and an accident.

Inspection

Warning

Use of the motorcycle with incorrectly adjusted, incorrectly routed, sticking or damaged throttle cables will interfere with the throttle function resulting in loss of motorcycle control and an accident.

To avoid incorrect adjustment, incorrect routing, or continued use of a sticking or damaged throttle, always have your throttle checked and adjusted by your authorised Triumph dealer.

Check that the throttle opens smoothly, without undue force and that it closes without sticking. Have your authorised Triumph dealer check the throttle system if a problem is detected or any doubt exists.

Check that there is 2 - 3 mm of throttle grip free play when lightly turning the throttle grip back and forth.

Maintenance and Adjustment

If there is an incorrect amount of free play, Triumph recommends that you have adjustments made by your authorised Triumph dealer. However, in an emergency, throttle adjustment may be made as follows:

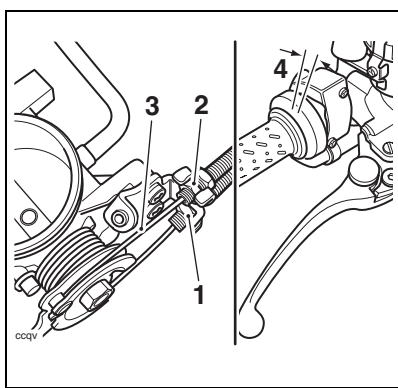

1. Opening cable adjuster
2. Closing cable adjuster
3. Closing cable – free play measurement point
4. Opening cable – free play measurement point

Adjustment

Remove the seat.

Disconnect the battery, negative (black) lead first.

Remove the fuel tank and airbox.

Release the locknut on the 'opening' cable adjuster.

Rotate the 'opening' cable adjuster at the twist grip end such that it has an equal amount of adjustment in each direction.

Rotate the 'opening' cable adjuster at the throttle body end of the cable to give 2 - 3 mm of play at the twist grip. Tighten the locknut.

Make any minor adjustments as necessary to give 2 - 3 mm of play using the adjuster near the twist grip end of the cable. Tighten the locknut.

With the throttle fully closed, ensure that there is 2 - 3 mm of free play in the 'closing' cable at the throttle cam attached to the throttle bodies. If necessary, adjust in the same way as the 'opening' cable until 2 - 3 mm of play is present.

Warning

Ensure that all the adjuster locknuts of all cables are tightened, as a loose locknut could result in a sticking throttle.

An incorrectly adjusted, sticking or stuck throttle can lead to loss of motorcycle control and an accident.

Refit the fuel tank and airbox.

Reconnect the battery, positive (red) lead first.

Refit the seats.

Check that the throttle opens smoothly, without undue force and that it closes without sticking.

Ride carefully to your nearest authorised Triumph dealer and have him check the throttle system thoroughly before riding again.

Maintenance and Adjustment

Clutch

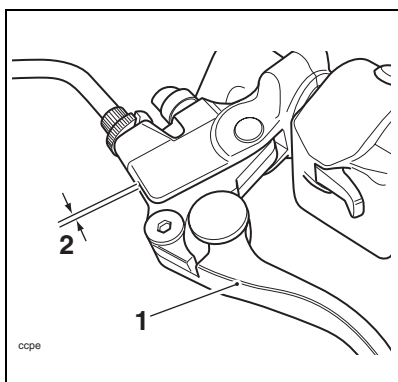

- 1. Clutch lever
- 2. 2 - 3 mm

The motorcycle is equipped with a cable-operated clutch.

If the clutch lever has excessive free play, the clutch may not disengage fully. This will cause difficulty in changing gear and selecting neutral. This may cause the engine to stall and make the motorcycle difficult to control. Conversely, if the clutch lever has insufficient free play the clutch may not engage fully, causing the clutch to slip, which will reduce performance and cause premature clutch wear.

Clutch lever free play must be checked in accordance with scheduled maintenance requirements.

Inspection

Check that there is 2 - 3 mm clutch lever free play at the lever.

If there is an incorrect amount of free play, adjustments must be made.

Adjustment

Loosen the knurled locknut at the lever end of the clutch cable and turn the adjuster sleeve until the correct amount of clutch lever free play is achieved.

Tighten the knurled locknut against the clutch lever assembly.

If correct adjustment cannot be made using the lever adjuster, use the cable adjuster at the lower end of the cable.

Loosen the adjuster locknut.

Turn the outer cable adjuster to give 2 - 3 mm of free play at the clutch lever.

Tighten the locknut.

Maintenance and Adjustment

Drive Chain



For safety and to prevent excessive wear, the drive chain must be checked, adjusted and lubricated in accordance with scheduled maintenance requirements. Checking, adjustment and lubrication must be carried out more frequently for extreme conditions such as salty or heavily gritted roads.

If the chain is badly worn or incorrectly adjusted (either too loose or too tight) the chain could jump off the sprockets or break. Therefore, always replace worn or damaged chains using genuine Triumph parts supplied by an authorised Triumph dealer.

Warning

A loose or worn chain, or a chain that breaks or jumps off the sprockets could catch on the engine sprocket or lock the rear wheel.

A chain that catches on the engine sprocket will injure the rider and lead to loss of motorcycle control and an accident. Similarly, locking the rear wheel will lead to loss of motorcycle control and an accident.

Chain Lubrication

Lubrication is necessary every 200 miles and also after riding in wet weather, on wet roads, or any time that the chain appears dry.

Use the special chain lubricant as recommended in the Specification section.

Apply lubricant to the sides of the rollers then allow the motorcycle to stand unused for at least 8 hours (overnight is ideal). This will allow the oil to penetrate to the chain O-rings etc.

Before riding, wipe off any excess oil.

If the chain is especially dirty, clean first and then apply oil as mentioned above.

Caution

Do not use a pressure wash to clean the chain as this may cause damage to the chain components.

Maintenance and Adjustment

Chain Free-Movement Inspection

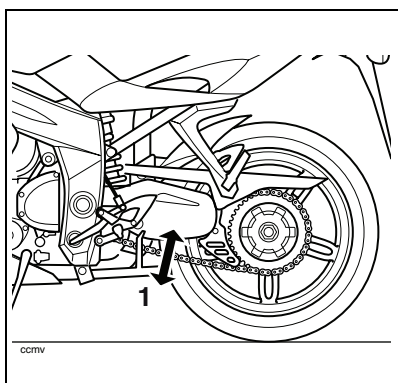

1. Maximum movement position

Warning

Before starting work, ensure the motorcycle is stabilised and adequately supported. This will help prevent injury to the operator or damage to the motorcycle.

Place the motorcycle on a level surface and hold it in an upright position with no weight on it.

Rotate the rear wheel by pushing the motorcycle to find the position where the chain is tightest, and measure the vertical movement of the chain midway between the sprockets.

The vertical movement of the drive chain must be in the range:

Model	Specification
Sprint ST	25 - 35 mm
Sprint GT	26 - 38 mm

Chain Free-Movement Adjustment

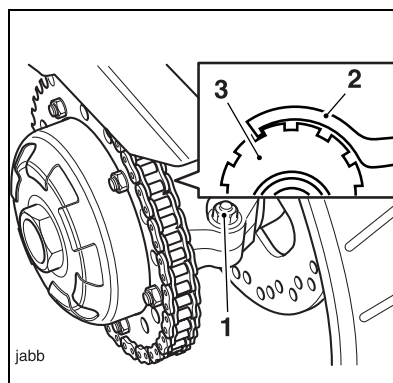

1. Adjuster clamp bolt
2. C-spanner
3. Eccentric adjuster

Loosen the adjuster clamp bolt.

Using the C-spanner supplied in the tool kit, turn the rear hub/eccentric adjuster (clockwise to loosen, anti-clockwise to tighten) until the drive chain is correctly adjusted.

Tighten the clamp bolt to **55 Nm**.

Repeat the chain adjustment check. Re-adjust if necessary.

Warning

Operation of the motorcycle with an insecure rear hub/eccentric adjuster clamp bolt may result in impaired stability and handling of the motorcycle. This impaired stability and handling may lead to loss of control or an accident.

Check the rear brake effectiveness.

Maintenance and Adjustment

Warning

It is dangerous to operate the motorcycle with defective brakes; you must have your authorised Triumph dealer take remedial action before you attempt to ride the motorcycle again. Failure to take remedial action may reduce braking efficiency leading to loss of control or an accident.

Chain and Sprocket Wear Inspection

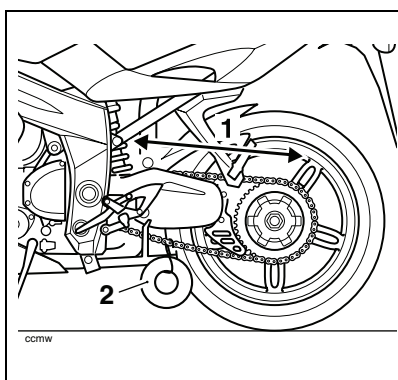

1. Measure across 20 links
2. Weight

Remove the chain guards.

Stretch the chain taut by hanging a 10 - 20 kg weight on the chain.

Measure the length of 20 links on the straight part of the chain from pin centre of the 1st pin to the pin centre of the 21st pin. Since the chain may wear unevenly, take measurements in several places.

If the length exceeds the maximum service limit of 321 mm, the chain must be replaced.

Rotate the rear wheel and inspect the drive chain for damaged rollers, and loose pins and links.

Also inspect the sprockets for unevenly or excessively worn or damaged teeth.

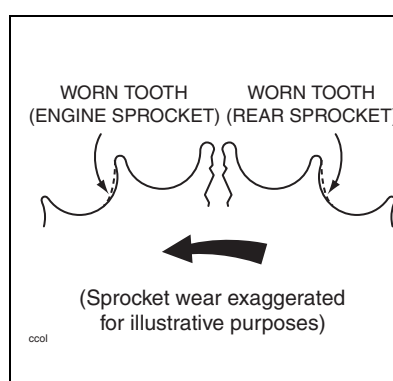

If there is any irregularity, have the drive chain and/or the sprockets replaced by an authorised Triumph dealer.

Refit the chain guards.

Warning

The use of non-approved chains may result in a broken chain or may cause the chain to jump off the sprockets.

Use a genuine Triumph supplied chain as specified in the Triumph parts catalogue.

Never neglect chain maintenance and always have chains installed by an authorised Triumph dealer.

Maintenance and Adjustment

Caution

If the sprockets are found to be worn, always replace the sprockets and drive chain together.

Replacing worn sprockets without also replacing the chain will lead to premature wear of the new sprockets.

Brakes

Brake Wear Inspection

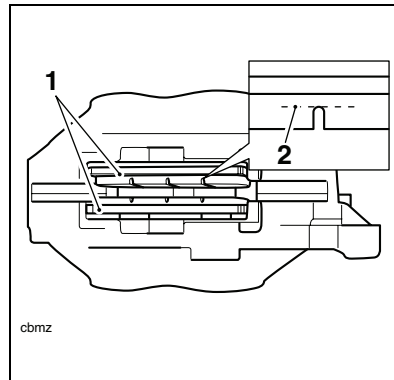

1. Brake pads

2. Minimum thickness line

Brake pads must be inspected in accordance with scheduled requirements and replaced if worn to, or beyond the minimum service thickness.

If the lining thickness of any pad (front or rear brakes) is less than 1.5 mm (0.06 in), that is, if the pad has worn down to the bottom of the grooves, replace all the pads on the wheel.

Maintenance and Adjustment

Breaking-in New Brake Pads and Discs

After replacement brake discs and/or pads have been fitted to the motorcycle, we recommend a period of careful breaking-in that will optimise the performance and longevity of the discs and pads. The recommended distance for breaking-in new pads and discs is 200 miles (300 km).

After fitting new brake discs and/or pads avoid extreme braking, ride with caution and allow for greater braking distances during the breaking-in period.

Warning

Brake pads must always be replaced as a wheel set. At the front, where two calipers are fitted on the same wheel, replace all the brake pads in both calipers.

Replacing individual pads will reduce braking efficiency and may cause an accident.

After replacement brake pads have been fitted, ride with extreme caution until the new pads have 'broken in'.

Brake Pad Wear Compensation

Disc and brake pad wear is automatically compensated for and has no effect on the brake lever or pedal action. There are no parts that require adjustment on the front and rear brakes.

Warning

If the brake lever or pedal feels soft when it is applied, or if the lever/pedal travel becomes excessive, there may be air in the brake pipes and hoses or the brakes may be defective.

It is dangerous to operate the motorcycle under such conditions and your authorised Triumph dealer must rectify the fault before riding.

Riding with defective brakes may lead to loss of motorcycle control and an accident.

Maintenance and Adjustment

Disc Brake Fluid

Inspect the level of brake fluid in both reservoirs and change the brake fluid in accordance with scheduled maintenance requirements. Use only DOT 4 fluid as recommended in the Specification section. The brake fluid must also be changed if it becomes, or is suspected of having become contaminated with moisture or any other contaminants.

Warning

Brake fluid is hygroscopic which means it will absorb moisture from the air.

Any absorbed moisture will greatly reduce the boiling point of the brake fluid causing a reduction in braking efficiency.

Because of this, always replace brake fluid in accordance with scheduled maintenance requirements.

Always use new brake fluid from a sealed container and never use fluid from an unsealed container or from one which has been previously opened.

Do not mix different brands or grades of brake fluid.

Check for fluid leakage around brake fittings, seals and joints and also check the brake hoses for splits, deterioration and damage.

Always rectify any faults before riding.

Failure to observe and act upon any of these items may cause a dangerous riding condition leading to loss of control and an accident.

Warning

If the ABS is not functioning, the brake system will continue to function as a standard non-ABS braking system. In this situation, braking too hard will cause the wheels to lock resulting in loss of control and an accident.

Reduce speed and do not continue to ride for longer than is necessary with the indicator light illuminated. Contact an authorised Triumph dealer as soon as possible to have the fault checked and rectified.

Warning

Failure to observe and act upon any of these items may cause a dangerous riding condition leading to loss of control and an accident.

Note:

- **On models fitted with ABS, a special tool is required to bleed the braking system. Contact your authorised Triumph dealer when the brake fluid needs renewing or the hydraulic system requires maintenance.**

Maintenance and Adjustment

Brake Fluid Level Inspection and Adjustment

The brake fluid level in both reservoirs must be kept between the upper and lower level lines (reservoir held horizontal).

Front Brake

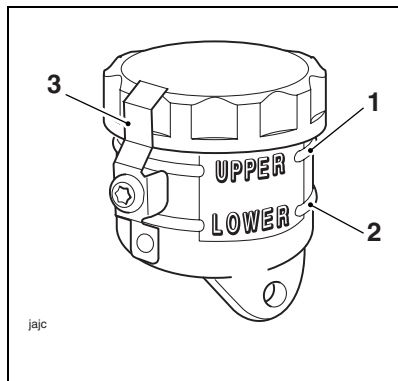

1. Front brake fluid reservoir, upper level line
2. Lower level line
3. Safety clip

Remove the safety clip.

Remove the reservoir cover.

Fill the reservoir to the upper level line using new DOT 4 fluid from a sealed container.

Refit the reservoir cover ensuring that the diaphragm seal is correctly fitted.

Refit the safety clip.

Warning

If there has been an appreciable drop in the level of the fluid in either fluid reservoir, consult your authorised Triumph dealer for advice before riding. Riding with depleted brake fluid levels, or with a brake fluid leak is dangerous and will cause reduced brake performance potentially leading to loss of motorcycle control and an accident.

Maintenance and Adjustment

Rear Brake - Sprint ST

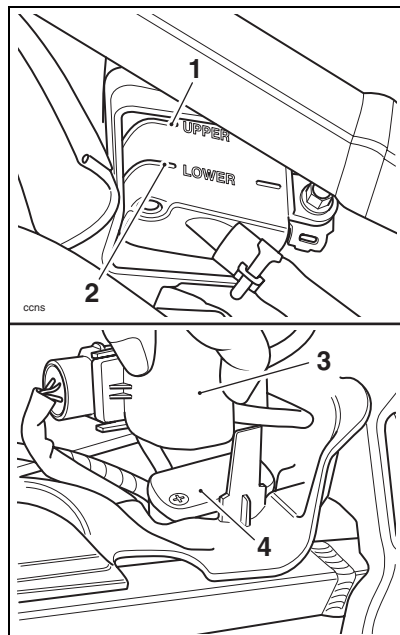

1. Upper level line
2. Lower level line
3. Starter solenoid/Main fuse assembly
4. Rear brake fluid reservoir

Level Inspection

The rear brake fluid level can be inspected without removing the seat. The reservoir is visible from the right hand side of the motorcycle, forward of the exhaust intermediate pipe, below the seat.

Level Adjustment

Remove the seat.

Disconnect the battery, negative (black) lead first.

The starter solenoid and main fuse are attached to a rubber mounting. This mounting fits over the rear brake fluid reservoir filler cap.

To gain access to the filler cap, gently pull off the starter solenoid/main fuse assembly with the rubber mounting.

Remove the reservoir cap. Fill the reservoir to the upper level line using new DOT 4 fluid from a sealed container.

Refit the reservoir cap ensuring that the diaphragm seal is correctly fitted.

Refit the starter solenoid/main fuse assembly.

Reconnect the battery, positive (red) lead first.

Refit the seat.

Maintenance and Adjustment

Rear Brake - Sprint GT

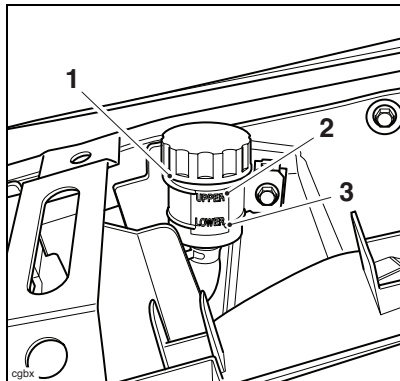

1. Rear brake fluid reservoir
2. Upper level line
3. Lower level line

Level Inspection and Adjustment

Remove the seat.

Remove the reservoir cap. Fill the reservoir to the upper level line using new DOT 4 fluid from a sealed container.

Refit the reservoir cap ensuring that the diaphragm seal is correctly fitted.

Refit the seat.

Brake Light Switches

The brake light is activated independently by either the front or rear brake. If, with the ignition in the ON position, the brake light does not work when the front brake lever is pulled or the rear brake pedal is pressed, have your authorised Triumph dealer investigate and rectify the fault.

Warning

Riding the motorcycle with defective brake lights is illegal and dangerous.

An accident causing injury to the rider and other road users may result from use of a motorcycle with defective brake lights.

Maintenance and Adjustment

Steering/Wheel Bearings

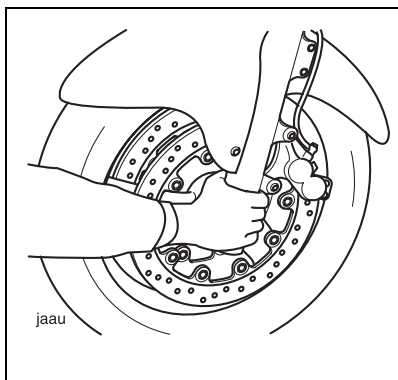

Steering Inspection

Lubricate and inspect the condition of the headstock (steering) bearings in accordance with scheduled maintenance requirements.

Note:

- **Always inspect the wheel bearings at the same time as the steering bearings.**

Warning

To prevent risk of injury from the motorcycle falling during the inspection, ensure that the motorcycle is stabilised and secured on a suitable support. Do not exert extreme force against each wheel or rock each wheel vigorously as this may cause the motorcycle to become unstable and cause injury by falling from its support. Ensure that the position of the support block will not cause damage to the sump.

Inspecting the Steering (Headstock) Bearings for Free Play

Position the motorcycle on level ground, in an upright position.

Raise the front wheel above the ground and support the motorcycle.

Standing at the front of the motorcycle, hold the lower end of the front forks and try to move them forward and backward.

If any free play can be detected in the steering (headstock) bearings, ask your authorised Triumph dealer to inspect and rectify any faults before riding.

Warning

Riding the motorcycle with incorrectly adjusted or defective steering (headstock) bearings is dangerous and may cause loss of motorcycle control and an accident.

Remove the support and place the motorcycle on the side stand.

Maintenance and Adjustment

Wheel Bearings Inspection

If the wheel bearings in the front or rear wheel allow play in the wheel hub, are noisy, or if the wheel does not turn smoothly, have your authorised Triumph dealer inspect the wheel bearings.

The wheel bearings must be inspected at the intervals specified in the scheduled maintenance chart.

Position the motorcycle on level ground, in an upright position.

Raise the front wheel above the ground and support the motorcycle.

Standing at the side of the motorcycle, gently rock the top of the front wheel from side to side.

If any free play can be detected, ask your authorised Triumph dealer to inspect and rectify any faults before riding.

Reposition the lifting device and repeat the procedure for the rear wheel.

Warning

Operation with worn or damaged front or rear wheel bearings is dangerous and may cause impaired handling and instability leading to an accident. If in doubt, have the motorcycle inspected by an authorised Triumph dealer before riding.

Remove the support and place the motorcycle on the side stand.

Front Suspension

Front Fork Inspection

Examine each fork for any sign of damage, scratching of the slider surface, or for oil leaks.

If any damage or leakage is found, consult an authorised Triumph dealer.

To check that the forks operate smoothly:

- Position the motorcycle on level ground.
- While holding the handlebars and applying the front brake, pump the forks up and down several times.
- If roughness or excessive stiffness is detected, consult your authorised Triumph dealer.
- The suspension movement will be affected by adjustment settings.

Warning

Riding the motorcycle with defective or damaged suspension is dangerous and may lead to loss of control and an accident.

Warning

Never attempt to dismantle any part of the suspension units, as all units contain pressurised oil. Skin and eye damage can result from contact with the pressurised oil.

Maintenance and Adjustment

Suspension Setting Chart

Note:

- **These charts are only a guide. Setting requirements may vary for rider weight and personal preferences. See the following pages for instructions on how to adjust your suspension.**

Sprint ST

LOADING	FRONT	REAR	
	Spring Pre-Load †	Rebound Damping*	Spring Pre-Load ‡
Solo Riding	3	1.5	20
Rider and Passenger or Rider and Luggage	3	1.0	10
Rider, Passenger and Luggage	3	0.5	0

† Adjuster rings visible above fork cap.
 * Number of adjuster turns in from the fully screwed out (hard) position.
 ‡ Number of clicks out from the fully screwed in position.

Sprint GT

LOADING	FRONT	REAR	
	Spring Pre-Load †	Rebound Damping*	Spring Pre-Load ‡
Solo Riding	3	1.0	30
Rider and Passenger or Rider and Luggage	3	0.25	20
Rider, Passenger and Luggage	3	0.25	0

† Adjuster rings visible above fork cap.
 * Number of adjuster turns in from the fully screwed out (hard) position.
 ‡ Number of clicks out from the fully screwed in position.

Front Suspension Settings

The standard suspension settings provide a comfortable ride and good handling characteristics for general, solo riding. The chart shows suggested settings for the front and rear suspension.

Warning

Ensure that the correct balance between front and rear suspension is maintained. Suspension imbalance could significantly change handling characteristics leading to loss of control and an accident. Refer to the chart on the previous page for further information or consult your dealer.

The front suspension is adjustable for pre-load only. The spring pre-load adjusters are located at the top of each fork.

Warning

Ensure that the adjusters are set to the same setting on both forks. Settings which vary from left to right could significantly change handling characteristics leading to loss of control and an accident.

Note:

- **The setting figures for the front suspension are measured as the number of adjuster rings visible above the fork top cap.**

Maintenance and Adjustment

Spring Pre-Load Adjustment

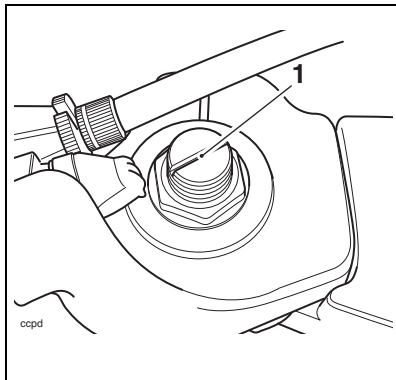

1. Spring pre-load adjuster

To change the spring pre-load, rotate the adjuster clockwise to increase pre-load, or anti-clockwise to decrease pre-load. Always set the pre-load adjusters such that there are an equal number of graduation lines visible on both forks.

Note:

- **The motorcycle is delivered from the factory with the spring pre-load set to three adjuster rings visible above the fork top cap.**

Rear Suspension Adjustment

The rear suspension unit is adjustable for rebound damping and spring pre-load.

Rebound Damping Adjustment

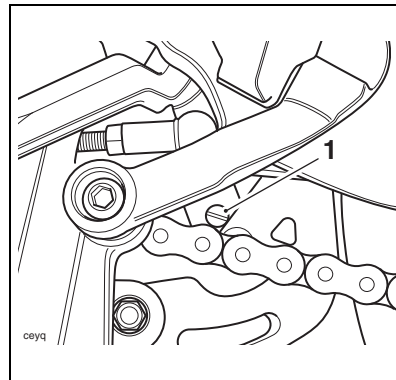

1. Rebound damping adjuster

The rebound damping adjuster is located at the bottom of the rear suspension unit on the left hand side of the motorcycle.

To adjust the rebound damping setting, rotate the adjuster clockwise to increase rebound damping and anti-clockwise to decrease.

Note:

- **The setting is measured as the number of adjuster turns in from the fully screwed out (hard) position.**
- **The motorcycle is delivered from the factory with the rebound adjuster set to 1.5 turns in from the fully screwed out (hard) position.**

Maintenance and Adjustment

Spring Pre-Load Adjustment - Sprint ST

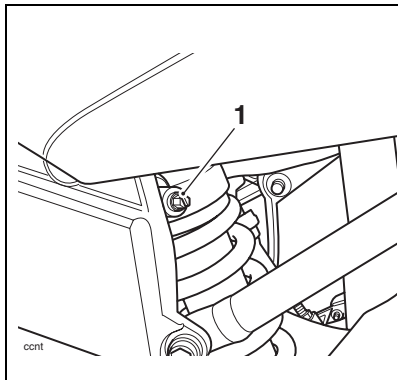

1. Spring pre-load adjuster

The spring pre-load adjuster is situated on the left hand side of the motorcycle, at the top of the rear suspension unit.

To adjust the spring pre-load setting rotate the slotted adjuster clockwise to increase, or anti-clockwise to decrease.

Note:

- The setting is measured as the number of adjuster 'clicks' out from the fully screwed in position.
- The motorcycle is delivered from the factory with the spring pre-load set to 20 'clicks' out from the fully screwed in position.

Spring Pre-Load Adjustment - Sprint GT

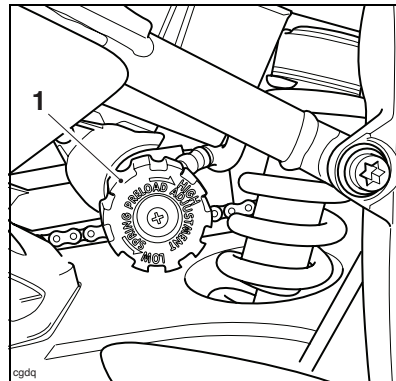

1. Spring pre-load adjuster

The spring pre-load adjuster is situated on the right hand side of the motorcycle, above the swinging arm.

To adjust the spring pre-load setting rotate the slotted adjuster clockwise to increase, or anti-clockwise to decrease.

Note:

- The setting is measured as the number of adjuster turns out from the fully screwed in position.
- The motorcycle is delivered from the factory with the spring pre-load set to 30 'clicks' out from the fully screwed in position.

Maintenance and Adjustment

Tyres

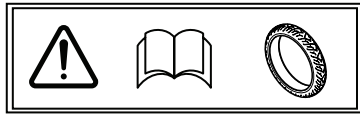

cb0a

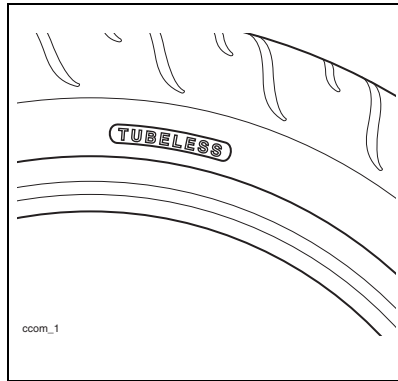

ccom_1

Typical Tyre Marking

This motorcycle is equipped with tubeless tyres, valves and wheel rims. Use only tyres marked 'TUBELESS' and tubeless valves on rims marked 'SUITABLE FOR TUBELESS TYRES'.

Tyre Inflation Pressures

Correct inflation pressure will provide maximum stability, rider comfort and tyre life. Always check tyre pressures before riding when the tyres are cold. Check tyre pressures daily and adjust if necessary. See the Specification section for details of the correct inflation pressures.

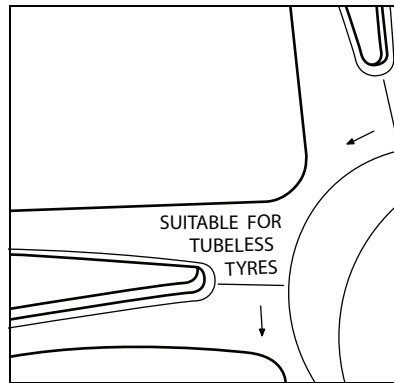

Wheel Marking

Warning

Incorrect tyre inflation will cause abnormal tread wear and instability problems that may lead to loss of control and an accident.

Under-inflation may result in the tyre slipping on, or coming off the rim. Over-inflation will cause instability and accelerated tread wear.

Both conditions are dangerous as they may cause loss of control leading to an accident.

Maintenance and Adjustment

Tyre Wear

As the tyre tread wears down, the tyre becomes more susceptible to punctures and failure. It is estimated that 90% of all tyre problems occur during the last 10% of tread life (90% worn). It is therefore not recommended to use tyres until they are worn to their minimum.

Minimum Recommended Tread Depth

In accordance with the periodic maintenance chart, measure the depth of the tread with a depth gauge, and replace any tyre that has worn to, or beyond the minimum allowable tread depth specified in the table below:

Under 130 km/h (80 mph)	2 mm (0.08 in)
Over 130 km/h (80 mph)	Rear 3 mm (0.12 in) Front 2 mm (0.08 in)

Warning

This motorcycle must not be operated above the legal road speed limit except in authorised closed-course conditions.

Warning

Only operate this Triumph motorcycle at high speed in closed-course on-road competition or on closed-course racetracks. High-speed operation should only then be attempted by riders who have been instructed in the techniques necessary for high-speed riding and are familiar with the motorcycle's characteristics in all conditions. High-speed operation in any other circumstances is dangerous and will lead to loss of motorcycle control and an accident.

Warning

Operation with excessively worn tyres is hazardous and will adversely affect traction, stability and handling which may lead to loss of control and an accident.

When tubeless tyres become punctured, leakage is often very slow. Always inspect tyres very closely for punctures. Check the tyres for cuts, embedded nails or other sharp objects. Operation with punctured or damaged tyres will adversely affect motorcycle stability and handling which may lead to loss of control or an accident.

Check the rims for dents or deformation. Operation with damaged or defective wheels or tyres is dangerous and loss of motorcycle control or an accident could result.

Always consult your authorised Triumph dealer for tyre replacement, or for a safety inspection of the tyres.

Maintenance and Adjustment

Tyre Replacement

All Triumph motorcycles are carefully and extensively tested in a range of riding conditions to ensure that the most effective tyre combinations are approved for use on each model. It is essential that approved tyres, fitted in approved combinations, are used when purchasing replacement tyres. The use of non-approved tyres, or approved tyres in non-approved combinations, may lead to motorcycle instability and an accident. On models fitted with ABS, different wheel speeds, caused by fitting non-approved tyres can affect the function of the ABS computer.

See the Specification section for details of approved tyre combinations. Always have tyres fitted and balanced by your authorised Triumph dealer who has the necessary training and skills to ensure safe, effective fitment.

Warning

On models fitted with ABS, the ABS computer operates by comparing the relative speed of the front and rear wheels. Use of non-recommended tyres can affect wheel speed and cause the ABS function not to operate, potentially leading to loss of control and an accident in conditions where the ABS would normally function.

Warning

If a tyre sustains a puncture, the tyre must be replaced. Failure to replace a punctured tyre, or operation with a repaired tyre can lead to instability, loss of control or an accident.

Warning

Do not install tube-type tyres on tubeless rims. The bead will not seat and the tyres could slip on the rims, causing rapid tyre deflation that may result in a loss of vehicle control and an accident. Never install an inner tube inside a tubeless tyre. This will cause friction inside the tyre and the resulting heat build-up may cause the tube to burst resulting in rapid tyre deflation, loss of vehicle control and an accident.

Warning

If tyre damage is suspected, such as after striking the kerb, ask your authorised Triumph dealer to inspect the tyre both internally and externally. Remember, tyre damage may not always be visible from the outside. Operation of the motorcycle with damaged tyres could lead to loss of control and an accident.

Maintenance and Adjustment

Warning

When replacement tyres are required, consult your authorised Triumph dealer who will arrange for the tyres to be selected, in a correct combination, from the approved list and fitted according to the tyre manufacturer's instructions.

When tyres are replaced, allow time for the tyres to seat to the rim (approximately 24 hours). During this seating period, ride cautiously as an incorrectly seated tyre could cause loss of control or an accident.

Initially, the new tyres will not produce the same handling characteristics as the worn tyres and the rider must allow adequate riding distance (approximately 100 miles) to become accustomed to the new handling characteristics.

24 hours after fitting, the tyre pressures must be checked and adjusted, and the tyres examined for correct seating. Rectification must be carried out as necessary.

The same checks and adjustments must also be carried out when 100 miles have been travelled after fitting.

Warning

Tyres that have been used on a rolling road dynamometer may become damaged. In some cases, the damage may not be visible on the external surface of the tyre. Tyres must be replaced after such use as continued use of a damaged tyre may lead to instability, loss of control and an accident.

Warning

Accurate wheel balance is necessary for safe, stable handling of the motorcycle. Do not remove or change any wheel balance weights. Incorrect wheel balance may cause instability leading to loss of control and an accident.

When wheel balancing is required, such as after tyre replacement, see your authorised Triumph dealer.

Only use self-adhesive weights. Clip-on weights may damage the wheel and tyre resulting in tyre deflation, loss of control and an accident.

Warning

Use of a motorcycle with incorrectly seated tyres, incorrectly adjusted tyre pressures, or when not accustomed to its handling characteristics may lead to loss of control and an accident.

Maintenance and Adjustment

Battery

Warning

Under some circumstances, the battery can give off explosive gases; keep sparks, flames and cigarettes away. Provide adequate ventilation when charging or using the battery in an enclosed space.

The battery contains sulphuric acid (battery acid). Contact with skin or eyes may cause severe burns. Wear protective clothing and a face shield.

If battery acid gets on your skin, flush with water immediately.

If battery acid gets in your eyes, flush with water for at least 15 minutes and SEEK MEDICAL ATTENTION IMMEDIATELY.

If battery acid is swallowed, drink large quantities of water and SEEK MEDICAL ATTENTION IMMEDIATELY.

KEEP BATTERY ACID OUT OF THE REACH OF CHILDREN.

Warning

The battery contains harmful materials. Always keep children away from the battery whether or not it is fitted in the motorcycle.

Do not attach jump leads to the battery, touch the battery cables together or reverse the polarity of the cables as any of these actions may cause a spark which would ignite battery gases causing a risk of personal injury.

Battery Removal

Sprint ST

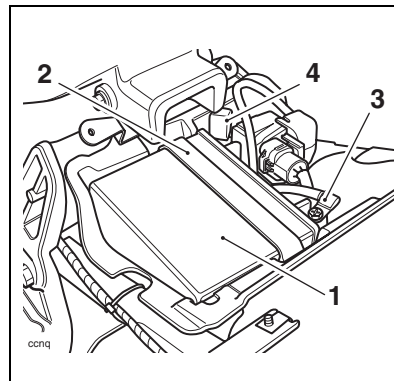

1. Battery
2. Battery Strap
3. Negative (black) terminal
4. Positive (red) terminal

Sprint GT

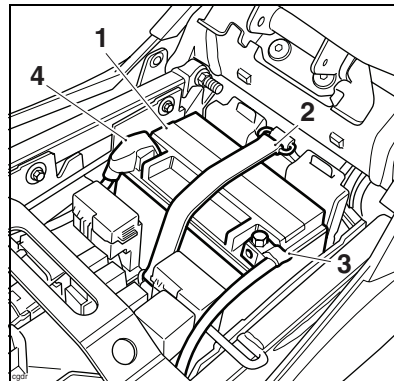

1. Battery
2. Battery strap
3. Negative (black) terminal
4. Positive (red) terminal

Maintenance and Adjustment

Remove the seat.
Remove the battery strap.
Disconnect the battery leads, negative (black) lead first.
Take the battery out of the case.

Warning

Ensure that the battery terminals do not touch the motorcycle frame as this may cause a short circuit or spark, which would ignite battery gases causing a risk of personal injury.

Battery Disposal

Should the battery ever require replacement, the original battery must be handed to a recycling agent who will ensure that the dangerous substances from which the battery is manufactured do not pollute the environment.

Battery Maintenance

Clean the battery using a clean, dry cloth. Be sure that the cable connections are clean.

Warning

The battery acid is corrosive and poisonous and will cause damage to unprotected skin. Never swallow battery acid or allow it to come into contact with the skin. To prevent injury, always wear eye and skin protection when handling the battery.

The battery is a sealed type and does not require any maintenance other than checking the Voltage and routine recharging when required, such as during storage.

It is not possible to adjust the battery acid level in the battery; the sealing strip must not be removed.

Battery Discharge

Caution

The charge level in the battery must be maintained to maximise battery life.
Failure to maintain the battery charge level could cause serious internal damage to the battery.

Maintenance and Adjustment

Under normal conditions, the motorcycle charging system will keep the battery fully charged. However, if the motorcycle is unused, the battery will gradually discharge due to a normal process called self discharge; the clock, engine control module (ECM) memory, high ambient temperatures, or the addition of electrical security systems or other electrical accessories will all increase this rate of battery discharge. Disconnecting the battery from the motorcycle during storage will reduce the rate of discharge.

Battery Discharge During Storage and Infrequent Use of the Motorcycle

During storage or infrequent use of the motorcycle, inspect the battery Voltage weekly using a digital multimeter. Follow the manufacturer's instructions supplied with the meter.

Should the battery Voltage fall below 12.7 Volts, the battery should be charged (see page 101).

Allowing a battery to discharge or leaving it discharged for even a short period of time causes sulphation of the lead plates. Sulphation is a normal part of the chemical reaction inside the battery, however over time the sulphate can crystallise on the plates making recovery difficult or impossible. This permanent damage is not covered by the motorcycle warranty, as it is not due to a manufacturing defect.

Keeping the battery fully charged reduces the likelihood of it freezing in cold conditions. Allowing a battery to freeze will cause serious internal damage to the battery.

Battery Charging

For help with selecting a battery charger, checking the battery Voltage or battery charging, contact your local authorised Triumph dealer.

Warning

The battery gives off explosive gases; keep sparks, flames and cigarettes away. Provide adequate ventilation when charging or using the battery in an enclosed space.

The battery contains sulphuric acid (battery acid). Contact with skin or eyes may cause severe burns. Wear protective clothing and a face shield.

If battery acid gets on your skin, flush with water immediately.

If battery acid gets in your eyes, flush with water for at least 15 minutes and SEEK MEDICAL ATTENTION IMMEDIATELY.

If battery acid is swallowed, drink large quantities of water and SEEK MEDICAL ATTENTION IMMEDIATELY.

KEEP BATTERY ACID OUT OF THE REACH OF CHILDREN.

Caution

Do not use an automotive quick charger as it may overcharge and damage the battery.

Should the battery Voltage fall below 12.7 Volts, the battery should be charged using a Triumph approved battery charger. Always remove the battery from the motorcycle and follow the instructions supplied with the battery charger.

Maintenance and Adjustment

For extended periods of storage (beyond two weeks) the battery should be removed from the motorcycle and kept charged using a Triumph approved maintenance charger.

Similarly, should the battery charge fall to a level where it will not start the motorcycle, remove the battery from the motorcycle before charging.

Battery Installation

Warning

Ensure that the battery terminals do not touch the motorcycle frame as this may cause a short circuit or spark, which would ignite battery gases causing a risk of personal injury.

- Place the battery in the battery case.
- Reconnect the battery, positive (red) lead first.
- Apply a light coat of grease to the terminals to prevent corrosion.
- Cover the positive terminal with the protective cap.
- Refit the battery strap.
- Refit the seat.

Fuse Box

Sprint ST

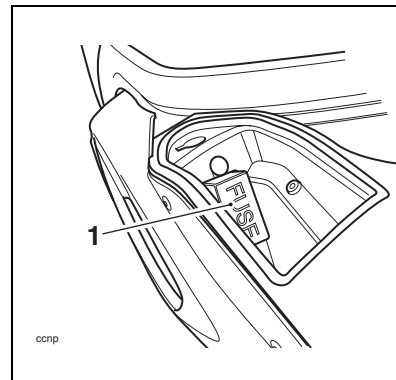

1. Fuse box

The fuse box is located beneath a removable panel on the right hand side of the front fairing.

To allow access to the fuse box, insert the ignition key and remove the panel.

Maintenance and Adjustment

Sprint GT

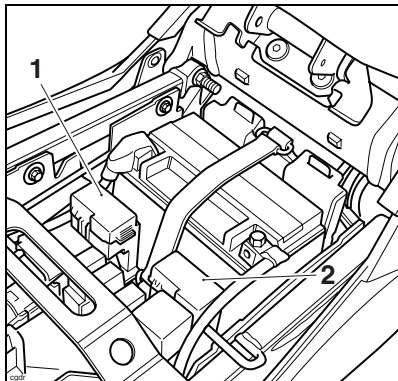

1. Left fuse box
2. Right fuse box

The fuse boxes are located beneath the seat. Remove the seat to access the fuse boxes.

Warning

Always replace blown fuses with new ones of the correct rating (as specified on the fuse box cover) and never use a fuse of higher rating. Use of an incorrect fuse could lead to an electrical problem, resulting in motorcycle damage, loss of motorcycle control and an accident.

Fuse Identification - Sprint ST

The fuses can be identified by a number moulded into the fusebox housing, adjacent to each fuse, as shown below. These numbers correspond to the numbers given in the table below. Fuses without an identification number are spare, and should be replaced if used.

A blown fuse is indicated when all of the systems protected by that fuse become inoperative. When checking for a blown fuse, use the table below to establish which fuse has blown.

Circuit Protected	Position	Rating (Amps)
Starter solenoid, dip and main beam headlights	1	20
Ignition switch main feed, tail lights, number plate light, side lights, fuel pump	2	10
Indicators, brake light, horn	3	10
Not used	4	
Not used	5	
Accessory socket, heated grips	6	10
Cooling fan	7	15
Engine management system	8	10
Alarm, diagnostic connector, instruments	9	10
GPS	10	2

Maintenance and Adjustment

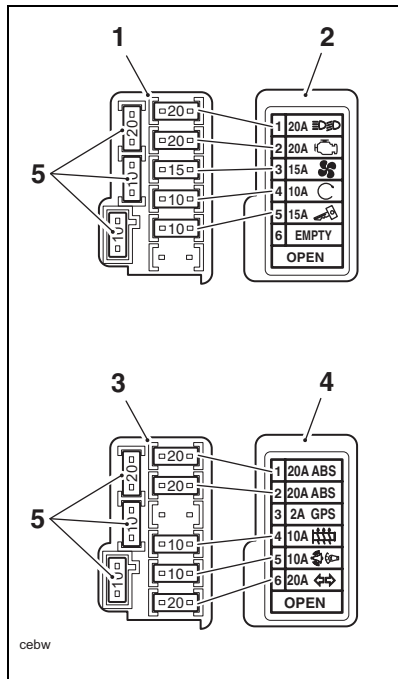

1. Fuse box number 1 (left hand)
2. Fuse box cover
3. Fuse box number 2 (right hand)
4. Fuse box cover
5. Spare fuses

Note:

- The starter solenoid has an additional 30 Amp fuse, attached directly to the solenoid, beneath the rider's seat.

Headlights

Warning

Adjust road speed to suit the visibility and weather conditions in which the motorcycle is being operated.

Ensure that the beams are adjusted to illuminate the road surface sufficiently far ahead without dazzling oncoming traffic. An incorrectly adjusted headlight may impair visibility causing an accident.

Warning

Never attempt to adjust a headlight beam when the motorcycle is in motion.

Any attempt to adjust a headlight beam when the motorcycle is in motion may result in loss of control and an accident.

Caution

If the motorcycle is to be used under closed-course conditions, you may be asked to tape the visible outer surface of the headlight.

When taped, the headlight will overheat and distort the outer surface. Therefore, to avoid headlight distortion, always disconnect the headlights when they are taped for use under closed-course conditions.

Maintenance and Adjustment

Headlight Adjustment

Each headlight can be adjusted by means of vertical and horizontal adjustment screws located on the top and rear of each headlight.

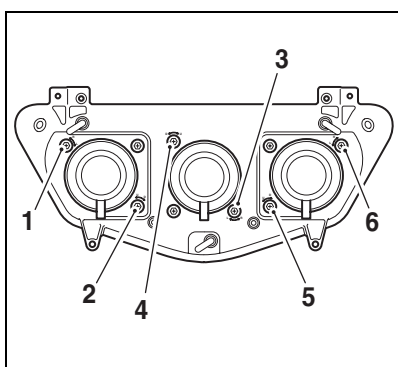

1. Horizontal adjustment screw (LH dipped headlight)
2. Vertical adjustment screw (LH dipped headlight)
3. Horizontal adjustment screw (main beam)
4. Vertical adjustment screw (main beam)
5. Vertical adjustment screw (RH dipped headlight)
6. Horizontal adjustment screw (RH dipped headlight)

Note:

- The illustration shows a view of the rear of the lighting assembly.
- When turning the adjustment screws, clockwise and anti-clockwise directions are as viewed from the rear of the lighting assembly.

Main Beam Horizontal Adjustment

The main beam horizontal adjustment screw is accessible without removing any panels. It can be reached from below the lights.

Switch the main beam on.

Turn the adjustment screw clockwise to move the beam to the left or anti-clockwise to move the beam to the right.

Switch the headlights off when the beam setting is satisfactory.

Main Beam Vertical Adjustment

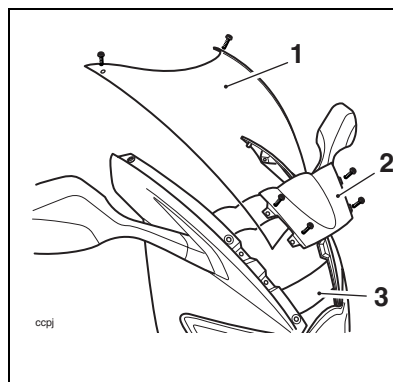

1. Windscreen
2. Cover panel
3. Adjustment screw access

Remove the screws securing the windscreen to the cockpit. Slide the windscreen upwards and to the rear to remove it.

Remove the screws securing the cover panel and remove the panel.

The adjustment screw is now accessible.

Switch the main beam on.

Maintenance and Adjustment

Turn the vertical adjustment screw clockwise to raise the beam or anti-clockwise to lower the beam.

Switch the headlights off when the beam setting is satisfactory.

Refit the cover panel and windscreen.

Dipped Headlight Vertical Adjustment

The dipped headlight vertical adjustment screws are accessible without removing any panels. They can be reached from below the lights on the left or right hand side. Turn the handlebars for ease of access.

Switch the headlight beam on.

Turn the vertical adjustment screws anti-clockwise to raise the beams or clockwise to lower the beams.

Switch the headlights off when the beam settings are satisfactory.

Dipped Headlight Horizontal Adjustment

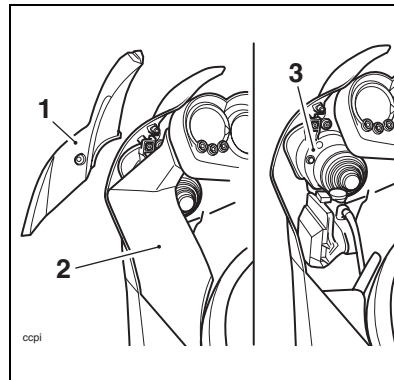

1. Left hand filler panel

2. Coolant expansion tank cover

3. Left hand headlight adjustment screw

Remove the left and right hand filler panels.

Remove the coolant expansion tank and stowage/fuse box cover panels. It is not necessary to remove the stowage box liner or the fuse box.

Switch the headlight dipped beam on.

The adjustment screws are now accessible.

On the right hand headlight, turn the horizontal adjustment screw clockwise to move the beam to the right, or anti-clockwise to move the beam to the left.

On the left hand headlight, turn the horizontal adjustment screw anti-clockwise to move the beam to the right, or clockwise to move the beam to the left.

Switch the headlights off when the beam settings are satisfactory.

Refit the cover and filler panels.

Maintenance and Adjustment

Dipped Headlight Bulb Replacement

It is not necessary to remove the dipped headlight when bulb replacement becomes necessary. The left and right filler panels, coolant expansion tank and stowage/fuse box cover panels do have to be removed.

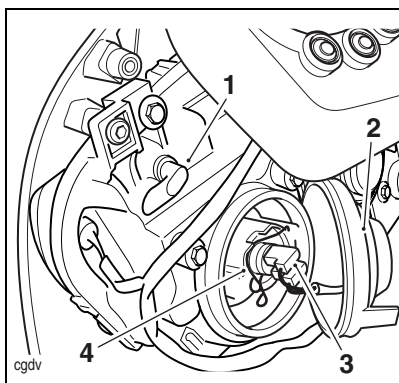

1. Headlight
2. Rubber cover
3. Multi-pin electrical connection
4. Bulb retainer

To replace a dipped headlight bulb:

Remove the seat.

Disconnect the battery, negative (black) lead first.

Remove the relevant filler and cover panels.

Remove the rubber cover and disconnect the multi-pin electrical connector from the bulb to be replaced.

Detach the wire bulb retainer from the clip. It is not necessary to undo the screw.

Remove the bulb from the headlight unit.

Installation is the reverse of the removal procedure.

Main Beam Bulb Replacement

It is necessary to remove the cockpit and the complete headlight unit when bulb replacement becomes necessary.

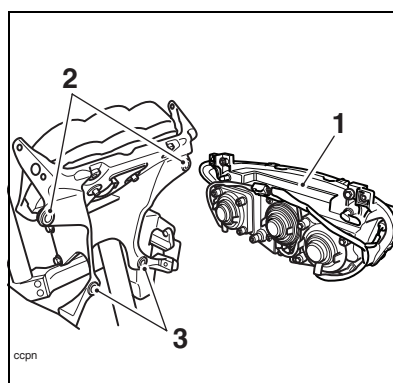

1. Headlight unit
2. Side fixing
3. Centre fixing

To replace a main beam bulb:

Remove the seat.

Disconnect the battery, negative (black) lead first.

Remove the cockpit.

Unscrew the nuts securing the headlight unit to the support bracket and release the unit.

Remove the rubber cover and disconnect the multi-pin electrical connector from the bulb to be replaced.

Detach the wire bulb retainer from the clip. It is not necessary to undo the screw.

Remove the bulb from the headlight unit.

Installation is the reverse of the removal procedure.

Maintenance and Adjustment

Warning

The bulbs become hot during use. Always allow sufficient time for the bulbs to cool before handling. Avoid touching the glass part of the bulb. If the glass is touched or gets dirty, clean with alcohol before re-use.

Position Lamp Bulb Replacement

The position lamps are fitted within the headlight aperture.

Carefully remove the rubber bulb holder from the back of the position lamp and detach the bulb.

Installation is the reverse of the removal procedure.

Caution

Ensure that the bulb holder is correctly fitted to prevent water ingress.

Warning

When reconnecting the battery, connect the positive (red) lead first.

Warning

Do not reconnect the battery until the assembly process has been completed. Premature battery reconnection could result in ignition of the battery gases causing risk of injury.

Rear Light

The rear light unit is a sealed, maintenance free LED unit.

Warning

Riding the motorcycle with defective brake lights is illegal and dangerous. In the event of failure of the LED unit, consult your authorised Triumph dealer.

An accident causing injury to the rider and other road users may result from use of a motorcycle with defective brake lights.

Maintenance and Adjustment

Direction Indicator Lights

Front Indicator Bulb Replacement

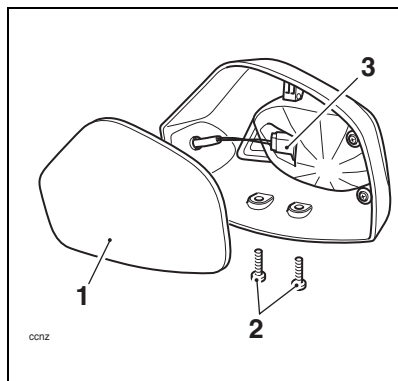

1. Mirror glass
2. Securing screws
3. Bulb holder

Release the screws on the underside of the mirror shell and remove the mirror glass to gain access to the bulb holder.

Caution

Support the mirror glass in case it falls out when releasing the screws.

Carefully remove the rubber bulb holder and detach the bulb.

Installation is the reverse of the removal procedure.

Rear Indicator Bulb Replacement

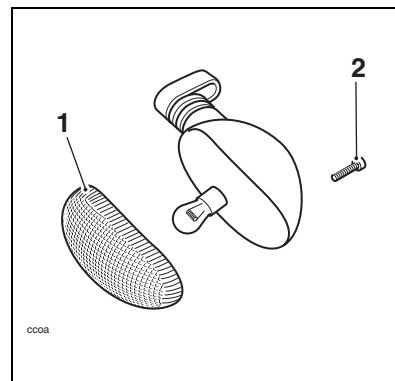

1. Indicator lens
2. Lens screw

The lens on each indicator light is held in place by a screw located in the body of the light.

Release the screws and remove the lens to gain access to the bulb for replacement.

Installation is the reverse of the removal procedure.

Maintenance and Adjustment

Licence Plate Light

Bulb Replacement

Carefully remove the rubber bulb holder from the back of the licence plate light unit and remove the bulb.

 **Caution**

To avoid cable damage, do not pull the bulb holder using the cables.

Installation is the reverse of the removal procedure.

 **Caution**

Ensure that the bulb holder is correctly fitted to prevent water ingress.

Windscreen Cleaning



Clean the windscreen with a solution of mild soap or detergent and lukewarm water. After cleaning, rinse well and then dry with a soft, lint free cloth.

 **Caution**

Products such as window cleaning fluids, insect remover, rain repellent, scouring compounds, petrol or strong solvents such as alcohol, acetone, carbon tetrachloride, etc. will damage the windscreen. Never allow these products to contact the windscreen.

If the transparency of the windscreen is reduced by scratches or oxidation which cannot be removed, the windscreen must be replaced.

Maintenance and Adjustment

Warning

Never attempt to clean the windscreen while the motorcycle is in motion as releasing the handlebars may cause loss of vehicle control and an accident.

Operation of the motorcycle with a damaged or scratched windscreen will reduce the rider's forward vision. Any such reduction in forward vision is dangerous and may lead to an accident causing injury or death.

Caution

Corrosive chemicals such as battery acid will damage the windscreen. Never allow corrosive chemicals to contact the windscreen.

Cleaning

Frequent, regular cleaning is an essential part of the maintenance of your motorcycle. If regularly cleaned, the appearance will be preserved for many years. Cleaning with cold water containing an automotive cleaner is essential at all times but particularly so after exposure to sea breezes, sea water, dusty or muddy roads and in winter when roads are treated for ice and snow. Do not use household detergent, as the use of such products will lead to premature corrosion.

Although, under the terms of your motorcycle warranty, cover is provided against the corrosion of certain items, the owner is expected to observe this reasonable advice which will safeguard against corrosion and enhance the appearance of the motorcycle.

Preparation for Washing

Before washing, precautions must be taken to keep water off the following places:

Rear opening of the exhausts: Cover with a plastic bag secured with rubber bands.

Clutch and brake levers, switch housings on the handlebar: Cover with plastic bags.

Ignition switch and steering lock: Cover the keyhole with tape.

Remove any items of jewellery such as rings, watches, zips or belt buckles, which may scratch or otherwise damage painted or polished surfaces.

Use separate cleaning sponges or cleaning cloths for washing painted/polished surfaces and chassis areas. Chassis areas (such as wheels and under mudguards) will be exposed to more abrasive road grime and dust, which may then scratch painted or polished surfaces, if the same sponge or cleaning cloths are used.

Maintenance and Adjustment

Where to be Careful

Avoid spraying water with any great force near the following places:

- Instruments;
- Brake cylinders and brake calipers;
- Under the fuel tank;
- Drive chain;
- Headstock bearings;
- Wheel bearings and suspension linkage bearings.

Caution

Do not spray any water at all under the cockpit area. The engine's air intake ducts are located in this area, and any water sprayed in this area could enter the airbox and engine, causing damage to both items.

Caution

Use of high-pressure spray washers is not recommended. When using pressure washers, water may be forced into bearings and other components causing premature wear from corrosion and loss of lubrication.

Note:

- **Use of soaps that contain high levels of alkaline will leave a residue on painted surfaces, and may also cause water spotting. Always use a low alkaline soap to aid the cleaning process.**

After Washing

Remove the plastic bags and tape, and clear the air intakes.

Lubricate the pivots, bolts and nuts.

Test the brakes before motorcycle operation.

Start the engine and run it for 5 minutes. Ensure adequate ventilation for the exhaust fumes.

Use a dry cloth to absorb water residue. Do not allow water to stand on the machine as this will lead to corrosion.

Warning

Never wax or lubricate the brake discs. Loss of braking power and an accident could result. Clean the disc with a proprietary brand of oil-free brake disc cleaner.

Seat Care

Caution

Use of chemicals or high-pressure spray washers is not recommended for cleaning the seat. When using chemicals or pressure washers the seat cover may get damaged.

To help maintain its appearance, clean the seat using a sponge or cleaning cloth with soap and water.

Maintenance and Adjustment

Unpainted Aluminium Items

Items such as brake and clutch levers must be correctly cleaned to preserve their appearance.

Use a proprietary brand of aluminium cleaner which does not contain abrasive or caustic elements.

Clean aluminium items regularly, in particular after use in inclement weather, where the components must be hand washed and dried each time the machine is used.

Warranty claims due to inadequate maintenance will not be allowed.

Cleaning of the Exhaust System

All parts of the exhaust system of your motorcycle must be cleaned regularly to avoid a deterioration of its appearance. These instructions can be applied to chrome, brushed stainless steel and carbon fibre components alike.

Note:

- **The exhaust system must be cool before washing to prevent water spotting.**

Washing

Prepare a mixture of cold water and mild automotive cleaner. Do not use a highly alkaline soap as commonly found at commercial car washes because it leaves a residue.

Wash the exhaust system with a soft cloth. Do not use an abrasive scouring pad or steel wool. They will damage the finish.

Rinse the exhaust system thoroughly.

Ensure no soap or water enters the exhausts.

Drying

Dry the exhaust system as far as possible with a soft cloth. Do not run the engine to dry the system or spotting will occur.

Protecting

When the exhaust system is dry, rub 'Motorex 645 Clean and Protect' into the surface.

Caution

The use of products containing silicone will cause discolouration of the chrome and must not be used. Similarly, the use of abrasive cleaners and polishes will damage the system and must not be used.

It is recommended that regular protection be applied to the system as this will both protect and enhance the system's appearance.

STORAGE

Preparation for Storage

Clean the entire vehicle thoroughly.

Fill the fuel tank with the correct grade of unleaded fuel and add a fuel stabiliser (if available), following the fuel stabiliser manufacturer's instructions.

 **Warning**

Petrol is extremely flammable and can be explosive under certain conditions. Turn the ignition switch off. Do not smoke. Make sure the area is well ventilated and free from any source of flame or sparks; this includes any appliance with a pilot light.

Remove the spark plug from each cylinder and put several drops (5 ml) of engine oil into each cylinder. Cover the spark plug holes with a piece of cloth or rag. With the engine stop switch in the RUN position, push the starter button for a few seconds to coat the cylinder walls with oil. Install the spark plugs, tightening to **12 Nm**.

Change the engine oil and filter (see page 73).

Check and if necessary correct the tyre pressures (see page 120).

Set the motorcycle on a box or stand so that both wheels are raised off the ground. (If this cannot be done, put boards under the front and rear wheels to keep dampness away from the tyres.)

Spray rust inhibiting oil (there are a host of products on the market and your dealer will be able to offer you local advice) on all unpainted metal surfaces to prevent rusting. Prevent oil from getting on rubber parts, brake discs or in the brake calipers.

Lubricate and if necessary adjust the drive chain (see page 87).

Make sure the cooling system is filled with a 50% mixture of anti-freeze and distilled water solution (see page 118).

Remove the battery, and store it where it will not be exposed to direct sunlight, moisture, or freezing temperatures. During storage it should be given a slow charge (one ampere or less) about once every two weeks (see page 100).

Store the motorcycle in a cool, dry area, away from sunlight, and with a minimum daily temperature variation.

Put a suitable porous cover over the motorcycle to keep dust and dirt from collecting on it. Avoid using plastic or similar non-breathable, coated materials that restrict air flow and allow heat and moisture to accumulate.

Storage

Preparation after Storage

Install the battery (if removed) (see page 102).

If the motorcycle has been stored for more than four months, change the engine oil (see page 73).

Check all the points listed in the Daily Safety Checks section.

Before starting the engine, remove the spark plugs from each cylinder.

Put the side stand down.

Crank the engine on the starter motor several times until the oil pressure light goes out.

Replace the spark plugs, tightening to **12 Nm**, and start the engine.

Check and if necessary correct the tyre pressures (see page 120).

Check the brakes for correct operation.

Test ride the motorcycle at low speeds.

Specifications

SPECIFICATIONS

	Sprint ST	Sprint GT
Dimensions		
Overall Length	2,114 mm (83.2 in)	2,260 mm (88.9 in)
Overall Width	745 mm (29.3 in)	940 mm (37 in)
Overall Height:	1,215 mm (47.8 in)	1,210 mm (47.6 in)
Wheelbase	1,457 mm (57.4 in)	1,565 mm (61.6 in)
Seat Height	820 mm (32.3 in)	815 mm (32.1 in)
Weights		
Wet Weight	241 kg (531 lbs)	268 kg (590 lbs)
Maximum Payload	215 kg (473 lbs)	215 kg (473 lbs)
Engine		
Type	In-line 3 cyl.	In-line 3 cyl.
Displacement	1050 cc	1050 cc
Bore x Stroke	79 x 71.4 mm	79 x 71.4 mm
Compression Ratio	12.0:1	12.0:1
Cylinder Numbering	Left to Right	Left to Right
Cylinder Sequence Number	1 at left	1 at left
Firing Order	1-2-3	1-2-3
Starting System	Electric Starter	Electric Starter

Specifications

	Sprint ST	Sprint GT
Performance		
Maximum Power*	125 PS (123 bhp) at 9,100 rpm	129.9 PS (128.2 bhp) at 9,200 rpm
Maximum Torque	103 Nm (76 ft.lbf) at 7,500 rpm	108 Nm (80 ft.lbf) at 6,300 rpm
Lubrication		
Type	Forced Lubrication (Wet sump)	Forced Lubrication (Wet sump)
Cooling		
Coolant Type	Triumph HD4X Hybrid OAT coolant	Triumph HD4X Hybrid OAT coolant
Water/Anti-freeze ratio	50/50 (pre-mixed as supplied by Triumph)	50/50 (pre-mixed as supplied by Triumph)
Coolant Capacity	2.3 litres	2.3 litres
Thermostat Opens (nominal)	85 - 88°C	85 - 88°C
Fuel System		
Type	Electronic Fuel Injection	Electronic Fuel Injection
Injectors	Twin Jet Solenoid Operated Plate Valve	Twin Jet Solenoid Operated Plate Valve
Fuel Pump	Submerged Electric	Submerged Electric
Fuel Pressure	2.94 bar (nominal)	2.94 bar (nominal)
Fuel		
Type	95 RON unleaded	95 RON unleaded
Steel Fuel Tank Capacity	20 litres	20 litres

* DIN 70020

Specifications

	Sprint ST	Sprint GT
Ignition		
Ignition System	Digital Inductive	Digital Inductive
Electronic Rev Limiter (r/min)	9,500 (r/min)	9,500 (r/min)
Spark Plug	NGK CR9EK	NGK CR9EK
Spark Plug Gap	0.7 mm	0.7 mm
Gap Tolerance	+0.05/-0.1 mm	+0.05/-0.1 mm
Transmission		
Transmission Type	6 Speed, Constant Mesh	6 Speed, Constant Mesh
Clutch Type	Wet, Multi-Plate	Wet, Multi-Plate
Final Drive Chain	DID X-Ring Endless, 106 Link	DID X-Ring Endless, 116 Link
Primary Drive Ratio	1.750 (105/60)	1.750 (105/60)
Gear Ratios:		
Final Drive Ratio	2.211 (19/42)	2.211 (19/42)
1st	2.733 (15/41)	2.733 (15/41)
2nd	1.947 (19/37)	1.947 (19/37)
3rd	1.545 (22/34)	1.545 (22/34)
4th	1.292 (24/31)	1.292 (24/31)
5th	1.154 (26/30)	1.154 (26/30)
6th	1.074 (27/29)	1:1 (28/28)

Specifications

	Sprint ST	Sprint GT
Tyres		
Tyre Pressures (Cold):		
Front	36 psi (2.5 bar)	36 psi (2.5 bar)
Rear	42 psi (2.9 bar)	42 psi (2.9 bar)
Approved tyres/sizes:		
Option 1		
Front	Bridgestone BT021 (FBZ) 120/70ZR17	Bridgestone BT021 (FBZ) 120/70ZR17
Rear	Bridgestone BT021 180/55ZR17	Bridgestone BT021 180/55ZR17
Option 2		
Front	Pirelli Angel ST 120/70ZR17 (A Specification)	Pirelli Angel ST 120/70ZR17 (A Specification)
Rear	Pirelli Angel ST 180/55ZR17 (E Specification)	Pirelli Angel ST 180/55ZR17 (E Specification)
Option 3		
Front	Dunlop Sportmax Roadsmart 120/70ZR17	Dunlop Sportmax Roadsmart 120/70ZR17
Rear	Dunlop Sportmax Roadsmart 180/55ZR17	Dunlop Sportmax Roadsmart 180/55ZR17
Option 4		
Front	Bridgestone BT020 120/70ZR17	Michelin Pilot Road II 120/70ZR17 (D Specification)
Rear	Bridgestone BT020 U 180/55ZR17	Michelin Pilot Road II 180/55ZR17 (B Specification)

Specifications

 **Warning**

Use the recommended tyres **ONLY** in the combinations given. Do not mix tyres from different manufacturers or mix different specification tyres from the same manufacturer as this may result in loss of motorcycle control and an accident.

Specifications

	Sprint ST	Sprint GT
Electrical Equipment		
Battery	12 Volt, 10 Ah	12 Volt, 12 Ah
Alternator	12 Volt, 35 Amp	12 Volt, 35 Amp
Headlight	3 x 12 Volt, 55 watt H7 halogen	3 x 12 Volt, 55 watt H7 halogen
Tail/Brake Light	LED	LED
Directional Indicator Lights	12 Volt, 10 watt	12 Volt, 10 watt
Frame		
Rake	24°	23.5°
Trail	90 mm	84 mm
Tightening Torques		
Oil Filter	10 Nm	10 Nm
Oil Drain Plug	25 Nm	25 Nm
Spark Plug	12 Nm	12 Nm
Rear Wheel Eccentric Clamp Bolt	55 Nm	55 Nm

Specifications

	Sprint ST	Sprint GT
Fluids and Lubricants		
Engine Oil	Semi or fully synthetic 10 W/40 or 15 W/50 motorcycle engine oil which meets specification API SH (or higher) and JASO MA.	Semi or fully synthetic 10 W/40 or 15 W/50 motorcycle engine oil which meets specification API SH (or higher) and JASO MA.
Brake and Clutch Fluid	Mobil Universal Brake and Clutch Fluid DOT 4	Mobil Universal Brake and Clutch Fluid DOT 4
Coolant	Triumph HD4X Hybrid OAT coolant (pre-mixed)	Triumph HD4X Hybrid OAT coolant (pre-mixed)
Bearings and Pivots	Mobil Grease HP 222	Mobil Grease HP 222
Drive Chain	Mobil Chain Spray or Mobilube HD 80	Mobil Chain Spray or Mobilube HD 80

Specifications

This page intentionally left blank

INDEX

B

Battery 99
 Charging 101
 Disposal 100
 Installation 102
 Maintenance 100
 Removal 99
 Brakes 84
 Brake and Clutch Lever Adjusters ... 31
 Brake Pad Wear Compensation 85
 Brake Wear Inspection 84
 Disc Brake Fluid 86
 Fluid Level 87
 Light Switches 89

C

Cleaning 112
 After Washing 113
 Drying 114
 Exhaust System 114
 Preparation 112
 Protecting 114
 Unpainted Aluminium Items 114
 Washing 114
 Where to be Careful 113
 Clock/Trip Computer 23
 Clutch 80
 Adjustment 80
 Inspection 80
 Cooling System 75, 118
 Coolant Change 77
 Coolant Level Inspection 76
 Corrosion Inhibitors 75
 Level Adjustment 76
 Radiator Hoses 77
 Temperature Gauge 25

D

Dimensions 117
 Drive Chain 81
 Chain Lubrication 81
 Movement Adjustment 82
 Movement Inspection 82
 Wear Inspection 83

E

Electrical Equipment 122
 Engine
 Serial Number 17
 Specifications 117
 To Start the Engine 50
 To Stop the Engine 50
 Engine Oil 71
 Disposal of Used Oil and Filters 74
 Oil Level Inspection 71
 Specification and Grade 74

F

Fluids and Lubricants 123
 Frame 122
 Fuel 118
 Fuel Gauge 26
 Fuel Requirement 34
 Filling the Fuel Tank 36
 Fuel Grade 34
 Fuel Tank Cap 35
 Fuel System 118
 Fuse Box 102
 Fuse Identification - Sprint GT 104
 Fuse Identification - Sprint ST 103

G

Gears
 Changing Gears 52

Index

H

Headlights	105
Adjustment	106
Dipped Headlight Adjustment	107
Dipped Headlight Bulb Replacement	108
Main Beam Headlight Adjustment	106
Main Beam Headlight Bulb Replacement	108
Position Lamp Bulb Replacement	109

I

Ignition	119
Key	29
Switch/Steering Lock	30
Instrument Panel Layout	21

L

Left Handlebar Switches	
Direction Indicator Switch	34
Horn Button	34
Pass Button	34
Licence Plate Light	111
Lubrication	118

O

Odometer/Trip Meter	22
-------------------------------	----

P

Pannier System - Sprint GT	41
Parts Identification	
Sprint GT	14
Sprint ST	12
Performance	118

R

Rear Light	109
Right Handlebar Switches	32
Engine Stop Switch	32
Starter Button	33

S

Safety	5
Fuel and Exhaust Fumes	5
Handlebars and Footrests	7
Helmet and Clothing	7
Maintenance/Equipment	9
Motorcycle	5
Parking	8
Parts and Accessories	8
Riding	6
Seat Care	113
Speedometer	22
Storage	115
Preparation after Storage	116
Preparation for Storage	115

T

Tachometer	22
Tightening Torques	122
Transmission	119
Tyres	120, 121

V

Vehicle Identification Number	17
---	----

W

Warnings	
Warning Label Locations	10
Warning Labels	2
Warning Lights	27
Warnings, Cautions and Notes	1
Weights	117
Windscreen Cleaning	111