

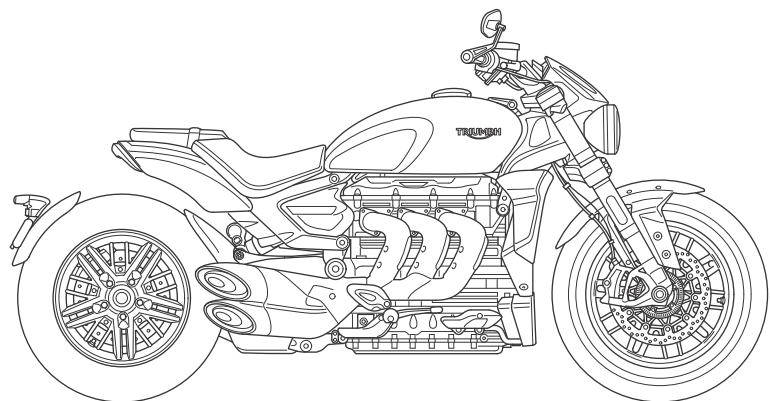

Owner's Handbook

Rocket 3 TFC



This handbook contains information on the Triumph Rocket 3 TFC motorcycle. Always store this Owner's Handbook with the motorcycle and refer to it for information whenever necessary.

The information contained in this publication is based on the latest information available at the time of printing. Triumph reserves the right to make changes at any time without prior notice, or obligation.

Not to be reproduced wholly or in part without the written permission of Triumph Motorcycles Limited.

© Copyright 05.2019 Triumph Motorcycles Limited, Hinckley, Leicestershire, England.

Publication part number 3855628-EN issue 1

Table of Contents

This handbook contains a number of different sections. The table of contents below will help you find the beginning of each section where, in the case of the major sections, a further table of contents will help you find the specific subject required.

Foreword.....	3
Safety First.....	7
Warning Labels.....	14
Parts Identification.....	16
Serial Numbers.....	19
Instruments.....	21
General Information.....	59
How to Ride the Motorcycle.....	93
Accessories, Loading and Passengers.....	109
Maintenance.....	113
Cleaning and Storage.....	155
Specifications.....	167
Index.....	171
Approval Information.....	175

Foreword

Warnings, Cautions and Notes

Throughout this Owner's Handbook particularly important information is presented in the following form:

 **Warning**

This warning symbol identifies special instructions or procedures, which if not correctly followed could result in personal injury, or loss of life.

 **Caution**

This caution symbol identifies special instructions or procedures, which, if not strictly observed, could result in damage to, or destruction of, equipment.

Note

This note symbol indicates points of particular interest for more efficient and convenient operation.

Warning Labels



At certain areas of the motorcycle, the symbol (above) can be seen. The symbol means CAUTION: REFER TO THE HANDBOOK and will be followed by a pictorial representation of the subject concerned and/or text.

Never attempt to ride the motorcycle or make any adjustments without reference to the relevant instructions contained in this handbook.

For the location of all labels showing this symbol, see the Warning Label Locations section of this Owner's Handbook. Where necessary, this symbol will also appear on the pages containing the relevant information.

Maintenance

To ensure a long, safe and trouble free life for your motorcycle, maintenance should only be carried out by an authorised Triumph dealer.

Only an authorised Triumph dealer will have the necessary knowledge, equipment and skills to maintain your Triumph motorcycle correctly.

To locate your nearest authorised Triumph dealer, visit the Triumph web site at www.triumph.co.uk or telephone the authorised distributor in your country. Their address is given in the service record book that accompanies this handbook.

Foreword

Noise Control System

Tampering with the noise control system is prohibited.

Owners are warned that the law may prohibit:

1. The removal or rendering inoperative by any person other than for purposes of maintenance, repair or replacement, of any device or element of design incorporated into any new vehicle for the purpose of noise control prior to its sale or delivery to the ultimate purchaser or while it is in use and,
2. the use of the vehicle after such device or element of design has been removed or rendered inoperative by any person.

Among those acts presumed to constitute tampering are the acts listed below:

- Removal of, or puncturing the muffler, baffles, header pipes or any other component which conducts exhaust gases.
- Removal of, or puncturing of any part of the intake system.
- Lack of proper maintenance.
- Replacing any moving parts of the vehicle, or parts of the exhaust or intake system, with parts other than those specified by the manufacturer.

Immobiliser and Tyre Pressure Monitoring System

This device complies with part 15 of the Federal Communications Commission (FCC) Rules.

Operation is subject to the following two conditions:

1. This device may not cause harmful interference.
2. This device must accept any interference received, including interference that may cause undesired operation.

Changes or modifications to the device could void the user's authority to operate the equipment.

Tyres

With reference to the Pneumatic Tyres and Tubes for Automotive Vehicles (Quality Control) Order, 2009, Cl. No. 3 (c), it is declared by M/s. Triumph Motorcycles Ltd. that the tyres fitted on this motorcycle meet the requirements of IS 15627: 2005 and comply with the requirements under Central Motor Vehicle Rules (CMVR), 1989.

Owner's Handbook

Warning

This Owner's Handbook, and all other instructions that are supplied with your motorcycle, should be considered a permanent part of your motorcycle and should remain with it even if your motorcycle is subsequently sold.

All riders must read this Owner's Handbook and all other instructions which are supplied with your motorcycle, before riding, in order to become thoroughly familiar with the correct operation of your motorcycle's controls, its features, capabilities and limitations.

Do not lend your motorcycle to others as riding when not familiar with your motorcycle's controls, features, capabilities and limitations can lead to an accident.

Thank you for choosing a Triumph motorcycle. This motorcycle is the product of Triumph's use of proven engineering, exhaustive testing, and continuous striving for superior reliability, safety and performance.

Please read this Owner's Handbook before riding in order to become thoroughly familiar with the correct operation of your motorcycle's controls, its features, capabilities and limitations.

This Owner's Handbook includes safe riding tips, but does not contain all the techniques and skills necessary to ride a motorcycle safely.

Triumph strongly recommends that all riders undertake the necessary training to ensure safe operation of this motorcycle.

This Owner's Handbook is available from your local dealer in:

- English
- US English
- Chinese
- Dutch
- French
- German
- Italian
- Japanese
- Portuguese
- Spanish
- Swedish
- Thai.

The languages available for this Owner's Handbook are dependent on the specific motorcycle model and country.

Talk to Triumph

Our relationship with you does not end with the purchase of your Triumph. Your feedback on the buying and ownership experience is very important in helping us develop our products and services for you.

Please help us by ensuring your authorised Triumph dealership has your email address and registers this with us. You will then receive an online customer satisfaction survey invitation to your email address where you can give us this feedback.

Your Triumph Team.

This page intentionally left blank

Safety First

The Motorcycle

Warning

This motorcycle is designed for on-road use only. It is not suitable for off-road use.

Off-road operation could lead to loss of control of the motorcycle resulting in an accident causing injury or loss of life.

Warning

This motorcycle is not designed to tow a trailer or be fitted with a sidecar.

Fitting a sidecar and/or a trailer may result in loss of control and an accident.

Warning

This motorcycle is designed for use as a two-wheeled vehicle capable of carrying a rider on his/her own, or a rider and one passenger.

The total weight of the rider, and any passenger, accessories and luggage must not exceed the maximum load limit stated in the Specifications section.

Warning

This motorcycle is fitted with a catalytic converter below the engine, which along with the exhaust system reaches very high temperature during engine operation.

Flammable materials such as grass, hay/straw, leaves, clothing and luggage etc. could ignite if allowed to come into contact with any part of the exhaust system and catalytic converter.

Always make sure that flammable materials are not allowed to contact the exhaust system or catalytic converter.

Safety First

Fuel and Exhaust Fumes

Warning

PETROL IS HIGHLY FLAMMABLE:

Always turn off the engine when refuelling.

Do not refuel or open the fuel filler cap while smoking or in the vicinity of any open (naked) flame.

Take care not to spill any petrol on the engine, exhaust pipes or silencers when refuelling.

If petrol is swallowed, inhaled or allowed to get into the eyes, seek immediate medical attention.

Spillage on the skin should be immediately washed off with soap and water and clothing contaminated with petrol should immediately be removed.

Burns and other serious skin conditions may result from contact with petrol.

Warning

Never start the engine or run the engine in a confined area.

Exhaust fumes are poisonous and can cause loss of consciousness and death within a short period of time.

Always operate the motorcycle in the open air or in an area with adequate ventilation.

Helmet and Clothing



Warning

When riding the motorcycle, both rider and passenger (on models where carrying a passenger is permitted) must always wear appropriate clothing including a motorcycle helmet, eye protection, gloves, boots, trousers (close fitting around the knee and ankle) and a brightly coloured jacket.

During off-road use (on models suitable for off-road use), the rider must always wear appropriate clothing including trousers and boots.

Brightly coloured clothing will considerably increase a rider's (or passenger's) visibility to other operators of road vehicles.

Although full protection is not possible, wearing correct protective clothing can reduce the risk of injury when riding.

Warning

A helmet is one of the most important pieces of riding gear as it offers protection against head injuries. You and your passenger's helmet should be carefully chosen and should fit you or your passenger's head comfortably and securely. A brightly coloured helmet will increase a rider's (or passenger's) visibility to other operators of road vehicles.

An open face helmet offers some protection in an accident though a full face helmet will offer more.

Always wear a visor or approved goggles to help vision and to protect your eyes.

Riding

Warning

Never ride the motorcycle when fatigued or under the influence of alcohol or other drugs.

Riding when under the influence of alcohol or other drugs is illegal.

Riding when fatigued or under the influence of alcohol or other drugs reduces the rider's ability to maintain control of the motorcycle and may lead to loss of control and an accident.

Warning

All riders must be licenced to operate the motorcycle.

Operation of the motorcycle without a licence is illegal and could lead to prosecution.

Operation of the motorcycle without formal training in the correct riding techniques that are necessary to become licenced is dangerous and may lead to loss of motorcycle control and an accident.

Warning

Always ride defensively and wear the protective equipment mentioned elsewhere in this foreword.

Remember, in an accident, a motorcycle does not give the same impact protection as a car.

Safety First

Warning

This Triumph motorcycle should be operated within the legal speed limits for the particular road travelled.

Operating a motorcycle at high speeds can be potentially dangerous since the time available to react to given traffic situations is greatly reduced as road speed increases.

Always reduce speed in potentially hazardous driving conditions such as bad weather or heavy traffic.

Warning

Continually observe and react to changes in road surface, traffic and wind conditions. All two-wheeled vehicles are subject to external forces which may cause an accident. These forces include but are not limited to:

- Wind draft from passing vehicles
- Potholes, uneven or damaged road surfaces
- Bad weather
- Rider error.

Always operate the motorcycle at moderate speed and away from heavy traffic until you have become thoroughly familiar with its handling and operating characteristics. Never exceed the legal speed limit.

Handlebars and Footrests

Warning

The rider must maintain control of the motorcycle by keeping hands on the handlebars at all times.

The handling and stability of a motorcycle will be adversely affected if the rider removes their hands from the handlebars, resulting in loss of motorcycle control and an accident.

Warning

The rider and passenger (if applicable) must always use the footrests provided, during operation of the motorcycle.

By using the footrests, both rider and passenger will reduce the risk of inadvertent contact with any motorcycle components and will also reduce the risk of injury from entrapment of clothing.

Warning

The bank angle indicators must not be used as a guide to how far the motorcycle may be safely banked.

This depends on many various conditions including, but not limited to, road surface, tyre condition and weather. Banking to an unsafe angle may cause instability, loss of motorcycle control and an accident.

Warning

Always replace the bank angle indicators before they are worn to their maximum limit.

Use of a motorcycle with bank angle indicators worn beyond the maximum limit will allow the motorcycle to be banked to an unsafe angle.

Banking to an unsafe angle may cause instability, loss of motorcycle control and an accident.

Warning

When banking and the bank angle indicator, attached to the rider's footrest, makes contact with the ground, the motorcycle is nearing its bank angle limit. A further increase of the banking angle is unsafe.

Banking to an unsafe angle may cause instability, loss of motorcycle control and an accident.

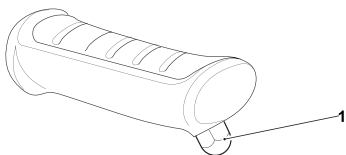

09c_1

1. Bank angle indicator

Maintenance and Equipment

Warning

Consult your authorised Triumph dealer whenever there is doubt as to the correct or safe operation of this Triumph motorcycle.

Remember that continued operation of an incorrectly performing motorcycle may aggravate a fault and may also compromise safety.

Warning

Make sure all equipment that is required by law is installed and functioning correctly.

The removal or alteration of the motorcycle's lights, silencers, emission or noise control systems can violate the law.

Incorrect or improper modification may adversely affect the handling, stability or other aspect of the motorcycle operation, which may result in an accident causing injury or death.

Warning

If the motorcycle is involved in an accident, collision or fall, it must be taken to an authorised Triumph dealer for inspection and repair.

Any accident can cause damage to the motorcycle that, if not correctly repaired, may cause a second accident that may result in injury or death.

Safety First

Parking

Warning

Always switch off the engine and remove the ignition key before leaving the motorcycle unattended. By removing the key, the risk of use of the motorcycle by unauthorised or untrained persons is reduced.

When parking the motorcycle, always remember the following:

- Engage first gear to help prevent the motorcycle from rolling off the stand.
- The engine and exhaust system will be hot after riding. DO NOT park where pedestrians, animals and/or children are likely to touch the motorcycle.
- Do not park on soft ground or on a steeply inclined surface. Parking under these conditions may cause the motorcycle to fall over.

For further details, please refer to the 'How to Ride the Motorcycle' section of this Owner's Handbook.

Parts and Accessories

Warning

Owners should be aware that the only approved parts, accessories and conversions for any Triumph motorcycle are those which carry official Triumph approval and are fitted to the motorcycle by an authorised dealer.

In particular, it is extremely hazardous to fit or replace parts or accessories whose fitting requires the dismantling of, or addition to, either the electrical or fuel systems and any such modification could cause a safety hazard.

The fitting of any non-approved parts, accessories or conversions may adversely affect the handling, stability or other aspect of the motorcycle operation that may result in an accident causing injury or death.

Triumph does not accept any liability whatsoever for defects caused by the fitting of non-approved parts, accessories or conversions or the fitting of any approved parts, accessories or conversions by non-approved personnel.

This page intentionally left blank

Warning Labels

Warning Labels

The labels detailed on this and the following pages indicate important safety information found in this handbook. Before riding, make sure that all riders have understood and complied with all the information to which these labels relate.

Warning Label Locations

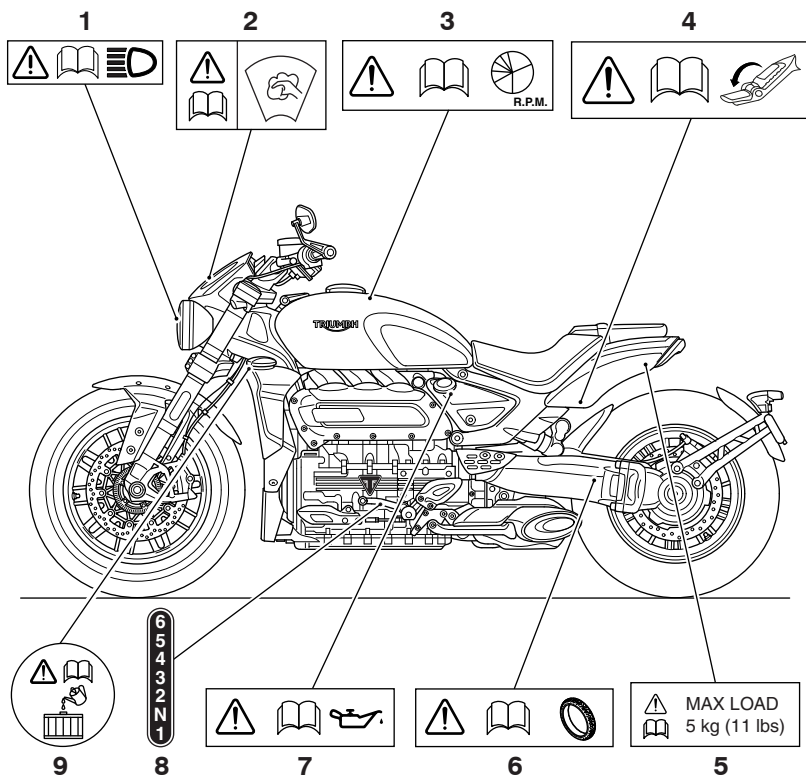

1. Headlight (page 150)
2. Windscreen (page 88)
3. Running-In (page 91)
4. Passenger Footrests (page 86)
5. Panniers (if fitted) (page 109)

6. Tyres (page 140)
7. Engine Oil (page 119)
8. Gear Position (page 96)
9. Coolant (page 124)

Warning Labels

⚠ Caution

All warning labels and decals, with the exception of the Running-in and Passenger Footrest labels, are fitted to the motorcycle using a strong adhesive.

In some cases, labels are installed prior to an application of paint lacquer. Therefore, any attempt to remove the warning labels will cause damage to the paintwork or bodywork.

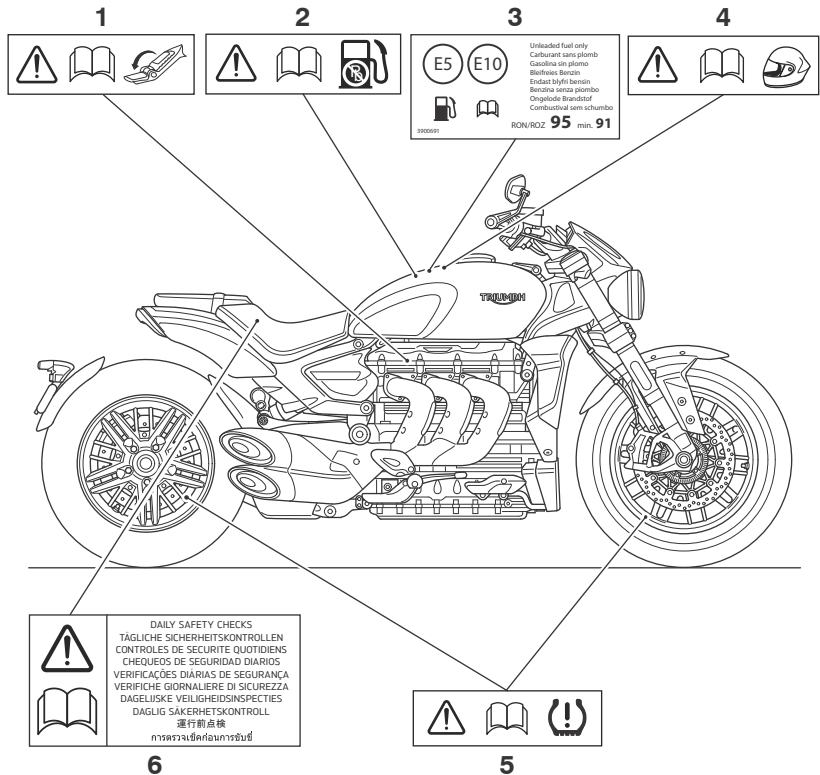

1. Daily Safety Checks (page 92)
2. Unleaded Fuel (page 78)
3. E5 and E10 Fuel (if fitted) (page 78)

4. Helmet (page 8)
5. Tyre Pressure Monitoring System (TPMS) (if fitted) (page 75)
6. Passenger Footrests (page 86)

Parts Identification

Parts Identification

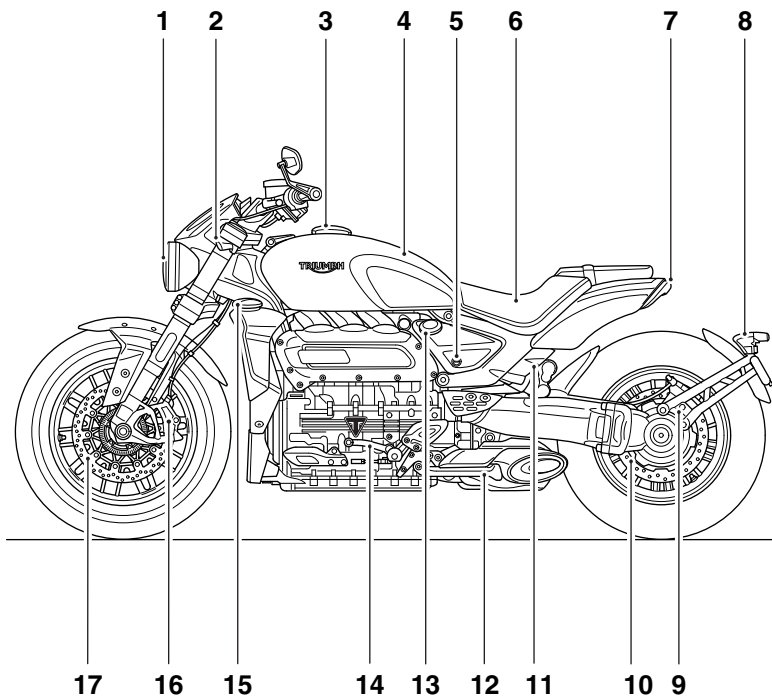

- | | |
|--------------------------------------|--------------------------------------|
| 1. Headlight | 10. Rear brake disc |
| 2. Front indicator | 11. Rear suspension preload adjuster |
| 3. Fuel filler cap | 12. Side stand |
| 4. Fuel tank | 13. Oil filler cap |
| 5. Seat lock | 14. Gear change pedal |
| 6. Battery (under the seat) | 15. Radiator cap |
| 7. Rear light | 16. Front brake caliper |
| 8. Number plate light and indicators | 17. Front brake disc |
| 9. Rear brake caliper | |

Parts Identification (Continued)

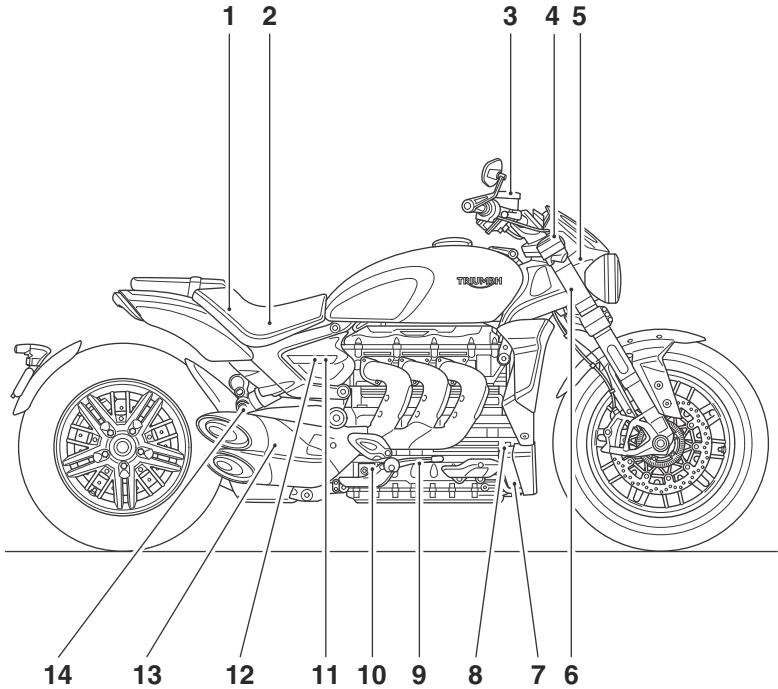

1. USB socket (under the seat)
2. Fuse box (under the seat)
3. Front brake fluid reservoir
4. Front suspension adjusters
5. Steering lock
6. Front fork
7. Coolant expansion tank
8. Coolant expansion tank cap

9. Rear brake pedal
10. Rear brake fluid reservoir
11. Tool kit (behind the side panel)
12. Rear rebound damping suspension adjuster (behind the side panel)
13. Silencer
14. Rear suspension compression damping adjuster

Parts Identification

Rider View Parts Identification

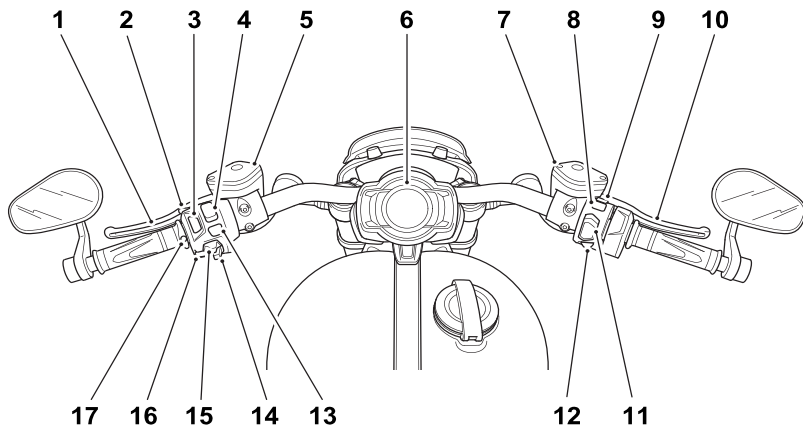

- | | |
|---------------------------------------|-------------------------------------|
| 1. Clutch lever | 12. Home button |
| 2. High beam button | 13. MODE button |
| 3. Daytime running lights (if fitted) | 14. Joystick button |
| 4. Cruise control adjust button | 15. Direction indicator switch |
| 5. Clutch fluid reservoir | 16. Horn button |
| 6. Multifunction display screen | 17. Heated grips switch (if fitted) |
| 7. Front brake fluid reservoir | |
| 8. Hazard warning lights button | |
| 9. Steering lock button | |
| 10. Front brake lever | |
| 11. Engine start/stop switch | |

Serial Numbers

Vehicle Identification Number (VIN)

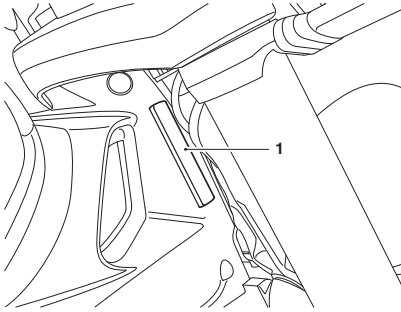

1. Vehicle identification number

The Vehicle Identification Number (VIN) is stamped into the steering head area of the frame. In addition, it is displayed on a label which is mounted on the right hand side of the front subframe.

Record the vehicle identification number in the space provided below.

Engine Serial Number

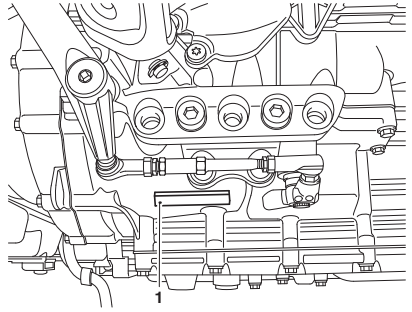

1. Engine serial number

The engine serial number is stamped on the bottom of the engine crankcase.

Record the engine serial number in the space provided below.

This page intentionally left blank

Instruments

Table of Contents

Instruments Panel Layout	23
Warning Lights	25
Engine Management System Malfunction Indicator Light (MIL)	25
Low Oil Pressure Warning Light	25
Immobiliser/Alarm Indicator Light	26
Anti-lock Braking System (ABS) Warning Light	26
Traction Control (TC) Indicator Light	26
Traction Control (TC) Disabled Warning Light	27
Direction Indicators	27
Hazard Warning Lights	27
High Beam Light	27
Daytime Running Lights (DRL) (if fitted)	28
Low Fuel Warning Light	28
General Warning Symbol	28
Ambient Air Temperature	29
Speedometer and Odometer	29
Tachometer	30
Fuel Gauge	30
Gear Position Display	31
Riding Modes	32
Riding Mode Selection	32
Information Tray	35
Warnings and Messages	35
Contrast	36
Themes	37
Detail	37
Trip Meters	38
Fuel	38
Coolant	39
Service Indicator and Odometer	40
Tyre Pressure Monitoring System (TPMS) (if fitted)	40

Instruments

Main Menu.....	41
Riding Modes.....	42
Riding Mode Configuration.....	43
Bike Setup Menu.....	44
Trip Setup Menu.....	48
Display Setup Menu.....	50
Reset to Defaults.....	55
Instrument Panel Position Adjustment.....	56

Instruments Panel Layout

There are two different themes available on the instrument display. Not all instrument features are available on all models.

Quartz Theme

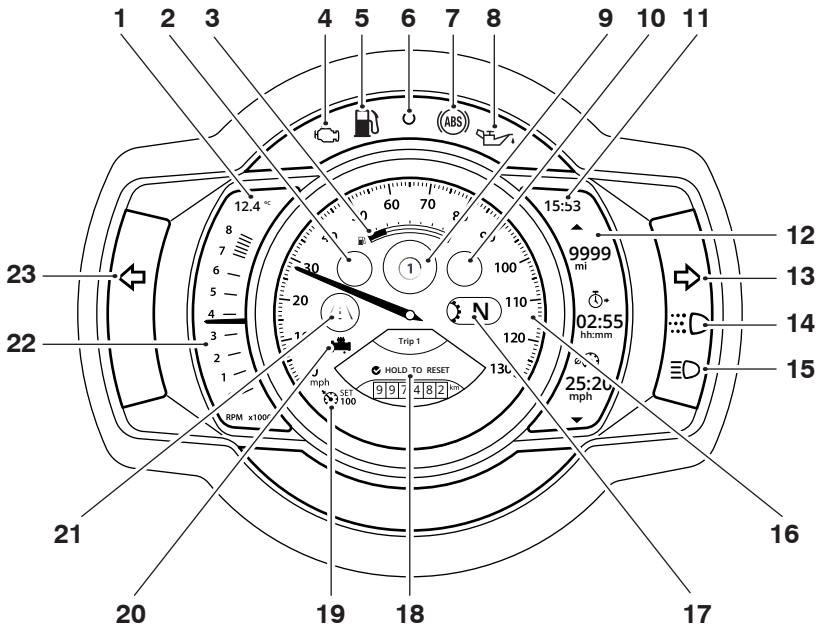

- | | |
|---|---|
| 1. Ambient air temperature | 11. Clock |
| 2. Warning light | 12. Right hand side display panel |
| 3. Fuel gauge | 13. Right hand indicator |
| 4. Engine management Malfunction Indicator Light (MIL) | 14. Daytime Running Light (DRL) (if fitted) |
| 5. Fuel level low warning light | 15. High beam warning light |
| 6. Alarm/immobiliser status indicator light (alarm is an accessory kit) | 16. Speedometer |
| 7. ABS warning light | 17. Gear position symbol |
| 8. Oil pressure warning light | 18. Information tray |
| 9. Information tray symbol/Riding mode symbol | 19. Cruise control SET indicator |
| 10. Warning light | 20. Heated grips status |
| | 21. Current riding mode |
| | 22. Tachometer/Left hand side display panel |
| | 23. Left hand indicator |

Instruments

Chronos Theme

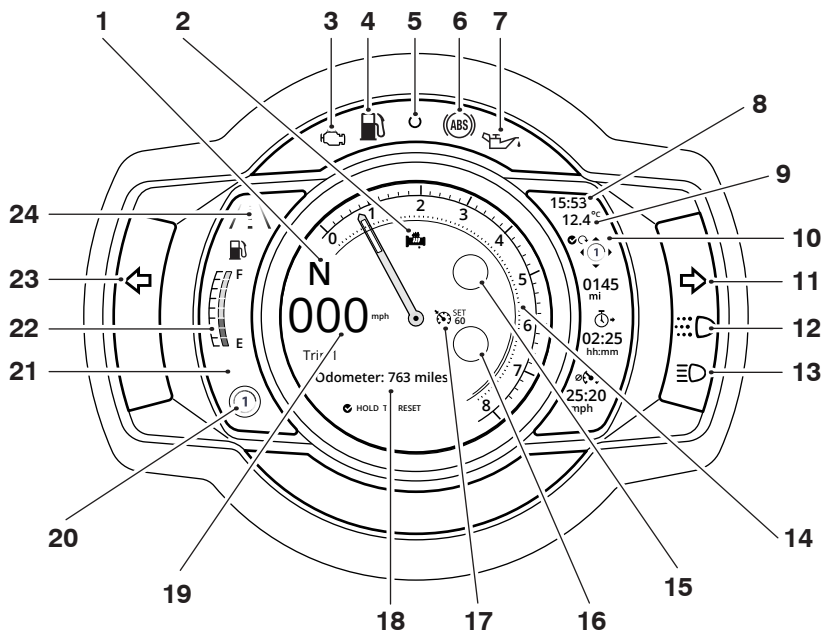

1. Gear position symbol
2. Heated grips status
3. Engine management Malfunction Indicator Light (MIL)
4. Fuel level low warning light
5. Alarm/immobiliser status indicator light (alarm is an accessory kit)
6. ABS warning light
7. Oil pressure warning light
8. Clock
9. Ambient air temperature
10. Right hand side display panel
11. Right hand indicator
12. Daytime Running Light (DRL) (if fitted)
13. High beam warning light
14. Tachometer
15. Warning light
16. Warning light
17. Cruise control speed/SET indicator
18. Information tray
19. Speedometer
20. Information tray symbol
21. Left hand panel
22. Fuel gauge
23. Left hand indicator
24. Current riding mode

Warning Lights

Note

When the ignition is switched on, the instrument warning lights will illuminate for 1.5 seconds and will then go off (except those which remain on until the engine starts, as described in the following pages).

For additional warning and information messages, see page 35.

Engine Management System Malfunction Indicator Light (MIL)



The Malfunction Indicator Light (MIL) for the engine management system illuminates when the ignition is switched ON (to indicate that it is working) but should not become illuminated when the engine is running.

If the engine is running and there is a fault with the engine management system the MIL will be illuminated and the general warning symbol will flash. In such circumstances, the engine management system may switch to 'limp-home' mode so that the journey may be completed, if the fault is not so severe that the engine will not run.

Warning

Reduce speed and do not continue to ride for longer than is necessary with the MIL illuminated. The fault may adversely affect engine performance, exhaust emissions and fuel consumption.

Reduced engine performance could cause a dangerous riding condition, leading to loss of control and an accident.

Contact an authorised Triumph dealer as soon as possible to have the fault checked and rectified.

Note

If the MIL flashes when the ignition is switched ON contact an authorised Triumph dealer as soon as possible to have the situation rectified. In these circumstances the engine will not start.

Low Oil Pressure Warning Light



With the engine running, if the engine oil pressure becomes dangerously low, the low oil pressure warning light will illuminate.

Caution

Stop the engine immediately if the low oil pressure warning light illuminates. Do not restart the engine until the fault has been rectified.

Severe engine damage will result from running the engine when the low oil pressure warning light is illuminated.

Instruments

Note

The low oil pressure warning light will illuminate if the ignition is switched ON without running the engine.

Immobiliser/Alarm Indicator Light

This Triumph motorcycle is fitted with an engine immobiliser which is activated when the ignition switch is turned to the OFF position.

Without Alarm Fitted

When the ignition switch is turned to the OFF position, the immobiliser light will flash on and off for 24 hours to show that the engine immobiliser is on. When the ignition switch is turned to the ON position the immobiliser and the indicator light will be off.

If the indicator light remains on it indicates that the immobiliser has a malfunction that requires investigation. Contact an authorised Triumph dealer as soon as possible to have the fault checked and rectified.

With Alarm Fitted

The immobiliser/alarm light will only illuminate when the conditions described in the genuine Triumph accessory alarm instructions are met.

Anti-lock Braking System (ABS) Warning Light



When the ignition switch is turned to the ON position, it is normal that the ABS warning light will flash on and off. The light will continue to flash after engine start-up until the motorcycle first reaches a speed exceeding 6 mph (10 km/h) when it will go off.

Note

Traction control will not function if there is a malfunction with the ABS. The warning lights for the ABS, traction control and the MIL will be illuminated.

The warning light will not illuminate again until the engine is restarted unless there is a fault.

If there is a fault with the ABS system the warning light will be illuminated and the general warning symbol will flash.

Warning

If the ABS is not functioning, the brake system will continue to function as a non-ABS braking system.

Do not continue to ride for longer than is necessary with the indicator light illuminated.

Contact an authorised Triumph dealer as soon as possible to have the fault checked and rectified. In this situation braking too hard will cause the wheels to lock resulting in loss of motorcycle control and an accident.

Traction Control (TC) Indicator Light



The Traction Control (TC) indicator light is used to indicate that the traction control system is active and is working to limit rear wheel slip during periods of hard acceleration or under wet or slippery road conditions.

Warning

If the traction control is not functioning, care must be taken when accelerating and cornering on wet/slippery road surfaces to avoid rear wheel spin.

Do not continue to ride for longer than is necessary with the engine management system Malfunction Indicator Light (MIL) and traction control warning lights illuminated. Contact an authorised Triumph dealer as soon as possible to have the fault checked.

Hard acceleration and cornering in this situation may cause the rear wheel to spin resulting in loss of motorcycle control and an accident.

If traction control is switched on:

- Under normal riding conditions the TC indicator light will remain off.
- The TC indicator light will flash rapidly when the traction control system is working to limit rear wheel slip during periods of hard acceleration or under wet or slippery road conditions.

If traction control is switched off:

- The TC indicator light will not illuminate. Instead the TC disabled warning light will be illuminated.

Note

Traction control will not function if there is a malfunction with the ABS system. The warning lights for the ABS, traction control and the MIL will be illuminated.

Traction Control (TC) Disabled Warning Light



The TC disabled warning light should not illuminate unless traction control is switched off or there is a malfunction.

If the warning light becomes illuminated at any other time while riding, it indicates that the traction control system has a malfunction that requires investigation.

Direction Indicators



When the direction indicator switch is turned to the left or right, the direction indicator warning light will flash on and

off at the same speed as the direction indicators.

Hazard Warning Lights

To turn the hazard warning lights on or off, press and release the hazard warning light switch.

The ignition must be switched ON for the hazard warning lights to function.

The hazard warning lights will remain on if the ignition is switched off, until the hazard warning light switch is pressed again.

High Beam Light



When the high beam button is pressed the high beam will be switched on. Each press of the button will swap between

dip and high beam.

Instruments

Note

If daytime running lights are fitted to the motorcycle, the high beam button has additional functionality.

If the DRL switch is in the daytime running lights position, then press and hold the high beam button to turn the high beam on. It will remain on as long as the button is held in and will turn off as soon as the button is released.

Note

A lighting on/off switch is not fitted to this model. The rear light and licence plate light all function automatically when the ignition is on.

The headlight will function when the ignition is on. The headlight will go off while pressing the starter button until the engine starts.

Daytime Running Lights (DRL) (if fitted)



When the ignition is switched ON and the daytime running lights switch is set to on, the daytime running lights warning light will illuminate.

The daytime running lights and low beam headlights are operated manually using a switch on the left hand switch housing, see page 66.

Warning

Do not ride for longer than necessary in poor ambient light conditions with the Daytime Running Lights (DRL) in use.

Riding with the Daytime Running Lights when dark, in tunnels or where poor ambient light is apparent may reduce the riders vision or dazzle other road users.

Dazzling other road users or reduced vision in low ambient light levels may result in loss of motorcycle control and an accident.

Note

During daylight hours the Daytime Running Lights (DRL) improve the motorcycles visibility to other road users.

Low beam headlights must be used in any other conditions unless the road conditions allow for high beam headlights to be used.

Low Fuel Warning Light



The low fuel warning light will illuminate when there are approximately 4 litres of fuel remaining in the tank.

General Warning Symbol



The general warning symbol will be shown in the information tray if an ABS or engine management fault has occurred and the ABS and/or MIL warning lights are illuminated. Contact an authorised Triumph dealer as soon as possible to have the fault checked and rectified.

Ambient Air Temperature

The ambient air temperature is displayed as either °C or °F.

When the motorcycle is stationary the heat of the engine may affect the accuracy of the ambient temperature display.

Once the motorcycle starts moving the display will return to normal after a short time.

To change the temperature from °C or °F see page 53.

Speedometer and Odometer

The speedometer indicates the road speed of the motorcycle.

The odometer shows the total distance that the motorcycle has travelled.

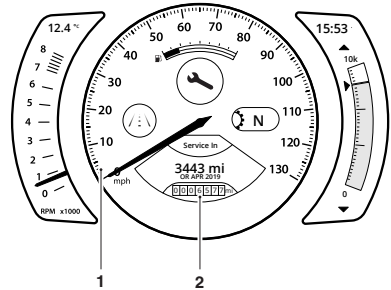

1. Speedometer
2. Odometer

This information is available in the Service tray.

Instruments

Tachometer

⚠ Caution

Never allow engine speed to enter the red zone as severe engine damage may result.

The tachometer shows the engine speed in revolutions per minute - rpm (r/min). At the end of the tachometer range there is the red zone.

Engine speeds in the red zone are above maximum recommended engine speed and are also above the range for best performance.

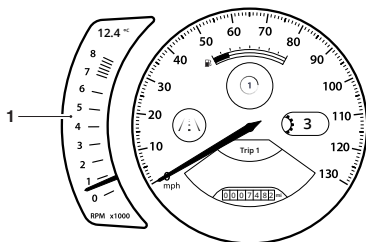

1. Engine speed (rpm)

The tachometer is shown in the main circle section of the instrument display when the Chronos theme is selected.

Fuel Gauge

The fuel gauge indicates the amount of fuel in the tank.

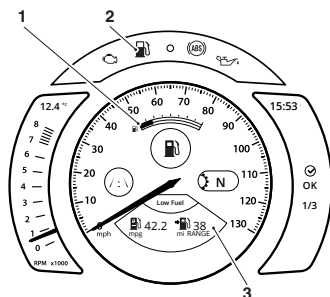

1. Fuel gauge
2. Low fuel warning light
3. Low fuel information tray

The fuel gauge is shown in the left hand panel when the Chronos theme is selected.

The range to empty and instantaneous fuel consumption is shown in the right hand panel when the Fuel menu is selected.

With the ignition switched on, a filled line in the fuel gauge indicates the fuel remaining in the fuel tank.

The gauge markings indicate intermediate fuel levels between an empty and full fuel tank.

The low fuel warning light will illuminate when approximately 4 litres of fuel is remaining in the tank and you should refuel at the earliest opportunity.

A low fuel warning message will appear in the information tray. Press the joystick centre to acknowledge and hide the low fuel warning.

After refuelling, the fuel gauge and range to empty information will be updated only while riding the motorcycle. Depending on the riding style, updating could take up to five minutes.

Gear Position Display

The gear position display indicates which gear (one to six) has been engaged. When the transmission is in neutral (no gear selected), the display will show N.

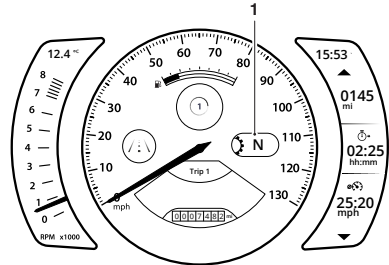

1. Gear position display (neutral position shown)

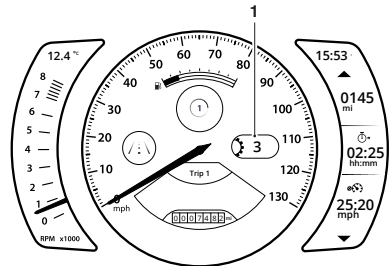

1. Gear position display (third gear shown)







Instruments

Riding Modes

The riding modes allow adjustment of the throttle response (MAP), Anti-lock Brake System (ABS) and Traction Control (TC) settings to suit differing road conditions and rider preferences. Riding modes are available depending on the motorcycle model's specification.

Riding modes can be conveniently selected using the MODE button and joystick located on the left hand switch housing, whilst the motorcycle is stationary or moving.

Each riding mode is adjustable. Availability of the ABS, MAP and TC setting options vary between models. For more information, see page 43. If a riding mode is edited (other than the Rider mode), the icon will change as shown below.

Default Icon	Rider Edited Icon	Description
	-	Rider
		Rain
		Road
		Sport

Riding Mode Selection

Warning

The selection of riding modes whilst the motorcycle is in motion requires the rider to allow the motorcycle to coast (motorcycle moving, engine running, throttle closed and no brakes applied) for a brief period of time.

Riding mode selection whilst the motorcycle is in motion should only be attempted:

- At low speed
- In traffic-free areas
- On straight and level roads or surfaces
- In good road and weather conditions
- Where it is safe to allow the motorcycle to briefly coast.

Riding mode selection whilst the motorcycle is in motion **MUST NOT** be attempted:

- At high speeds
- Whilst riding in traffic
- During cornering or on winding roads or surfaces
- On steeply inclined roads or surfaces
- In poor road/weather conditions
- Where it is unsafe to allow the motorcycle to coast.

Failure to observe this important warning may lead to loss of motorcycle control and an accident.

Warning

If traction control has been disabled in the Main Menu as described on page 46 then settings saved for all riding modes will be overridden.

Traction control will remain off regardless of your riding mode selection until re-enabled, or the ignition has been switched off then on again, or the MODE button is held in to return to the default Road mode (which enables the traction control when the motorcycle is next stationary).

If the traction control is disabled, the motorcycle will handle as normal but without traction control. In this situation accelerating too hard on wet/slippery road surfaces may cause the rear wheel to slip, and may result in loss of motorcycle control and an accident.

Warning

If the ABS is disabled, the brake system will function as a non-ABS equipped braking system. In this situation braking too hard will cause the wheels to lock, and may result in loss of motorcycle control and an accident.

Warning

After selecting a riding mode, operate the motorcycle in an area free from traffic to gain familiarity with the new settings.

Do not loan your motorcycle to anyone as they may change the riding mode settings from the one you are familiar with, causing loss of motorcycle control and an accident.

To select a riding mode:

- Press and release the MODE button on the left hand switch housing to activate the riding mode information tray and riding mode selection panel.
- The currently active riding mode icon is shown in the centre of the instrument panel.

To change the selected riding mode:

- Either push the joystick left or right, or repeatedly press the MODE button until the required mode is shown in the centre of the display screen or highlighted in the riding mode selection panel.

Instruments

- A brief press of the joystick centre will select the required riding mode.

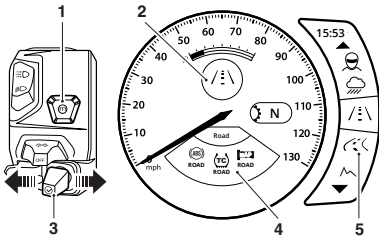

1. **MODE button**
2. **Current riding mode**
3. **Joystick**
4. **Information tray showing riding mode settings**
5. **Riding mode selection panel**

- Push the joystick left/right or press the MODE button to scroll through the riding mode options.

The selected mode is activated once the following conditions for switching modes have been met:

Motorcycle Stationary - Engine Off

- The ignition is switched ON.
- The engine stop switch is in the RUN position.

Motorcycle Stationary - Engine Running

- Neutral gear is selected.

Motorcycle in Motion

Within 30 seconds of selecting a riding mode the rider must carry out the following simultaneously:

- Close the throttle.
- Make sure that the brakes are not engaged (allow the motorcycle to coast).

Note

It is not possible to switch into or out of Rider mode whilst the motorcycle is in motion, if the ABS or TC settings are set to OFF in either of those modes.

In this case, the motorcycle must be brought to a stop before the riding mode change can take place.

If a riding mode change is not completed, the icon will alternate between the previous riding mode and the newly selected riding mode until the change is complete or it is cancelled.

The riding mode selection is now complete and normal riding can be resumed.

Information Tray

Warning

When the motorcycle is in motion, only attempt to switch between the information tray modes or reset the fuel information under the following conditions:

- At low speed
- In traffic free areas
- On straight and level roads or surfaces
- In good road and weather conditions.

Failure to observe this important warning could lead to loss of motorcycle control and an accident.

The information tray appears at the bottom of the display screen and allows easy access to different motorcycle status information.

To view the different information tray items:

- Push the joystick left/right until the required information tray item is shown.

Note

To access the information tray, any warning messages must first be acknowledged, see page 35.

The information tray contains the following items:

- Warnings and Information Messages, see page 35
- Contrast, see page 36
- Theme Options, see page 37
- Detail, see page 37

- Trip Meter, see page 38
- Fuel Information, see page 38
- Coolant Temperature, see page 39
- Service Interval Announcement and Odometer, see page 40
- Tyre Pressure Monitoring System (TPMS) (if fitted), see page 40.

Different information tray items can be shown or hidden from the information tray. For further information, refer to page 51.

Warnings and Messages

Any warnings and information messages are shown in the information tray. An example is shown below.

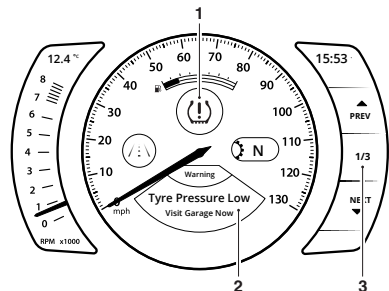

1. Warning symbol (TPMS shown)
2. Warning and/or message description
3. Warning and/or message counter

To view the warnings and messages:

- Push the joystick left/right to scroll through the options until the warning review is shown.
- Push the joystick down/up to review each warning (if more than one). The warning counter will show the amount of warnings that are present.

Instruments

- Push the joystick left/right to return to the information tray.

Low Battery Warning

If items such as heated grips are fitted and are on with the engine at idle, over a period of time, the battery voltage may drop below a predetermined voltage and a warning message will be shown in the information tray.

Contrast

The Contrast information tray menu allows the display screen contrast to be adjusted.

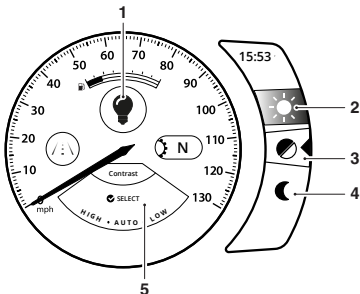

1. Contrast symbol
2. HIGH contrast
3. AUTO contrast
4. LOW contrast
5. Contrast information tray

There are three options available:

- HIGH - This option locks the display screen to the white background version of each display screen style for maximum visibility.

- AUTO - This option uses the instrument light sensor to adjust the contrast to the most suitable setting. In bright sunlight, low brightness settings will be overridden to make sure that the instruments can be viewed at all times.
- LOW - This option locks the display screen to the dark background version of each display screen for night time visibility.

To select an option:

- Push the joystick down/up to select either the HIGH, AUTO or LOW contrast option and press the joystick centre to confirm.
- If the rider defined brightness setting is suitable this will be used, see page 50.

Note

Do not cover the light sensor in the left hand panel on the display screen as this will stop the screen contrast from working correctly.

Themes

The Theme options information tray menu allows a different theme to be applied to the display screen.

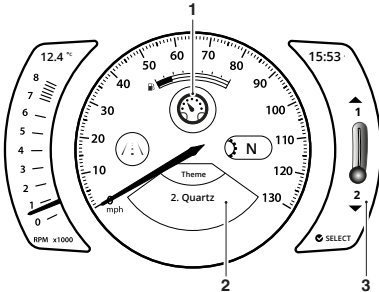

1. Theme symbol
2. Theme information tray
3. Theme slider bar

To change the theme:

- Push the joystick down/up to select the required theme and then press the joystick centre to confirm.
- A slider bar in the right hand side panel also indicates the choice of theme.

Detail

The Detail information tray menu allows the level of detail to be shown or hidden in the display screen.

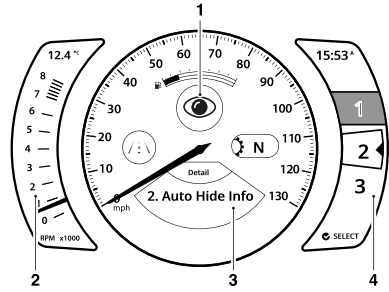

1. Detail symbol
2. Left hand panel
3. Information tray
4. Right hand panel

There are three options available:

- Auto Hide All - This option hides all information in the left hand panel, right hand panel and the information tray.
- Auto Hide Info - This option hides all information in the left hand panel and right hand panel. Information will still be shown in the information tray.
- Show All - This option shows information in the left hand panel, right hand panel and the information tray.

To select an option:

- Push the joystick down/up to select the required Detail option.

Instruments

Note

There is a short time delay when using the joystick to select the option, and the option then being hidden or shown in the display screen. Make sure that the joystick isn't held whilst the option is waiting to appear or hide the information. If the joystick is pressed, the information then reappears until the next option is selected.

- Once the required Detail option is chosen, press the joystick centre to confirm.
- The Detail options are also numbered and shown in the right hand side display panel.

Trip Meters

There are two trip meters that can be accessed and reset in the information tray.

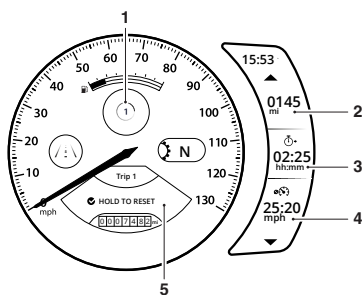

1. Trip symbol
2. Distance travelled
3. Time taken
4. Average speed
5. Trip information tray

To view a specific trip meter:

- Push the joystick left/right to scroll through the information tray items until Trip 1 meter is shown.

- Select Trip 1 or Trip 2 by pushing the joystick down/up.

Note

Trip 2 meter can be shown or hidden from the information tray. For more information, see page 49.

To reset a trip meter:

- Select the trip meter to be reset.
- Press and hold the joystick centre for more than one second.
- The trip meter will then be reset.

The trip meter can also be reset from the Main menu, see page 48.

Fuel

The Fuel status information tray shows fuel consumption information.

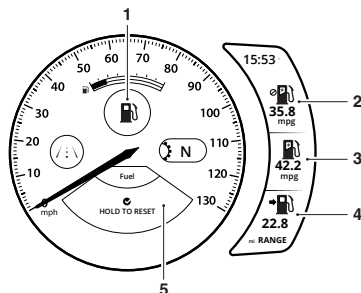

1. Fuel symbol
2. Average fuel consumption
3. Instantaneous fuel consumption
4. Range to empty
5. Fuel information tray

Average Fuel Consumption

This is an indication of the average fuel consumption. After being reset the display will show dashes until 0.1 miles/km has been covered.

Instantaneous Fuel Consumption

An indication of the fuel consumption at an instant in time. If the motorcycle is stationary, --- will be shown in the display area.

Range to Empty

This is an indication of the predicted distance that can be travelled on the remaining fuel in the tank.

Reset

To reset the average fuel consumption, press and hold the joystick centre.

Note

After refuelling, the fuel gauge and range to empty information will be updated only while riding the motorcycle. Depending on the riding style, updating could take up to five minutes.

Coolant

The coolant information tray menu indicates the temperature of the engine coolant.

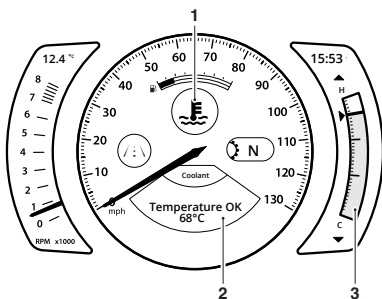

1. Coolant symbol
2. Coolant information tray
3. Coolant temperature gauge

The coolant temperature is shown in the information tray with a status message. The coolant temperature is also shown in a gauge in the right hand side display section. The gauge ranges between C (cold) and H (hot). When the engine is started from cold the gauge will show grey bars. As the temperature increases more bars in the gauge will be shown illuminated. When the engine is started from hot the gauge will show the relevant number of illuminated bars, dependant on engine temperature.

With the engine running, if the coolant temperature becomes dangerously high, the high coolant temperature warning light on the display will be illuminated and a message will be shown in the information tray.

⚠ Caution

Stop the engine immediately if the high coolant temperature warning light illuminates. Do not restart the engine until the fault has been rectified.

Severe engine damage will result from running the engine when the high coolant temperature warning light is illuminated.

Instruments

Service Indicator and Odometer

The Service Indicator display shows the service symbol, the distance/days remaining before the next service and the current odometer reading. The odometer reading shows the total distance that the motorcycle has travelled.

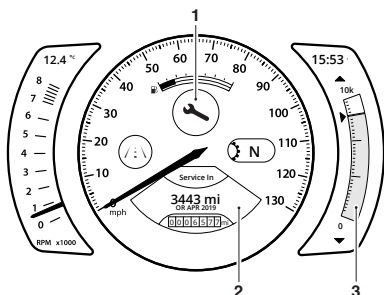

1. Service symbol
2. Service indicator information tray
3. Service indicator gauge

For more information on service indicator announcements, see page 46.

Tyre Pressure Monitoring System (TPMS) (if fitted)

The Tyre Pressure Monitoring System (TPMS) information tray item shows the front and rear tyre pressures. For more information on TPMS, see page 75.

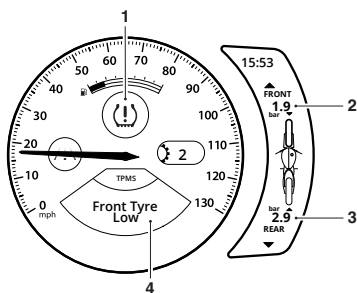

1. TPMS symbol
2. Front tyre pressure display
3. Rear tyre pressure display
4. TPMS information tray

Main Menu

To access the Main Menu:

- The motorcycle must be stationary with the ignition switched on.
- Press the HOME button on the right handlebar switch housing.
- Scroll the Main Menu by pushing the joystick down/up until the required option is selected and then press the joystick centre to confirm.

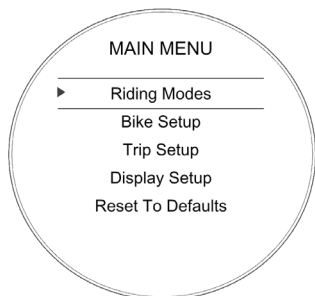

The Main Menu allows access to the following options:

Riding Modes

This menu allows configuration of the riding modes. For more information, see page 42.

Bike Setup

This menu allows configuration of the different features of the motorcycle. For more information, see page 44.

Trip Setup

This menu allows configuration of Trip 1 and Trip 2 meters. For more information, see page 48.

Display Setup

This menu allows configuration of the display options. For more information, see page 50.

Reset to Defaults

This menu allows all instrument settings to be returned to the default setting. For more information, see page 55.

Instruments

Riding Modes

To change the riding modes settings:

- From the Riding Modes menu, push the joystick down/up to select a specific riding mode and press the joystick centre to confirm.

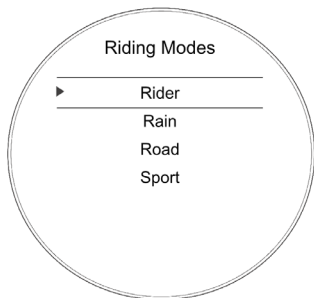

- Push the joystick down/up until the required option is selected and press the joystick centre to confirm.





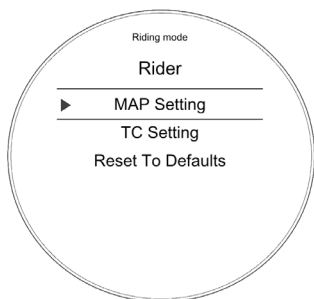

- Push the joystick down/up until the required setting option is selected and press the joystick centre to confirm.



Riding Mode Configuration

Riding modes are available depending on the motorcycle model's specification. Refer to the following table for the ABS, MAP and TC options available for each riding mode.

Riding Mode				
	Rider 	Rain 	Road 	Sport 
Anti-lock Braking System (ABS)				
Road	●	●	●	●
MAP (Throttle Response)				
Rain	○	●	○	⊘
Road	●	○	●	○
Sport	○	⊘	○	●
Traction Control (TC)				
Rain	○	●	○	⊘
Road	●	○	●	○
Sport	○	⊘	○	●
Off	○	Via Menu	Via Menu	Via Menu
Key				
●	Standard (Factory Default Setting)			
○	Selectable Option			
⊘	Option Not Available			

Instruments

ABS Options

Warning

If the ABS is disabled, the brake system will function as a non-ABS braking system. In this situation braking too hard will cause the wheels to lock, and may result in loss of motorcycle control and an accident.

ABS Option Descriptions

Road and Sport - Optimal ABS setting for road use.

Rain - Optimal ABS setting for rain use.

MAP Options

MAP Option Descriptions

Road - Standard throttle response.

Rain - Reduced throttle response when compared to the Road setting for wet or slippery conditions.

Sport - Increased throttle response when compared to the Road setting.

Traction Control Options

Warning

If the traction control is disabled, the motorcycle will handle as normal but without traction control.

In this situation accelerating too hard on wet/slippery road surfaces may cause the rear wheel to slip which may result in loss of motorcycle control and an accident.

Traction Control Option Descriptions

Road - Optimal traction control setting for road use. Allows a small amount of rear wheel slip.

Rain - Optimal traction control setting for wet or slippery conditions. Allows reduced rear wheel slip when compared with the Road setting.

Sport - Allows increased rear wheel slip when compared with the Road setting.

Bike Setup Menu

From the Main menu, select Bike Setup and push the joystick button to confirm.

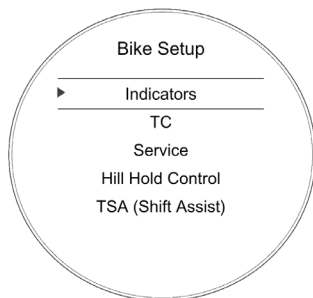

The Bike Setup menu allows access to the following options:

- Indicators
- Traction Control (TC)
- Service
- Hill Hold Control
- Triumph Shift Assist (TSA).

Bike Setup - Direction Indicators

The direction indicators can be set to Auto Basic, Auto Advanced or Manual mode.

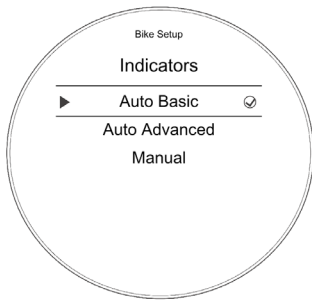

To select the required direction indicators mode:

- From the Bike Setup menu, push the joystick down to select Indicators and press the joystick centre to confirm.

- Push the joystick down/up to scroll between Auto Basic, Auto Advanced or Manual.
 - Auto Basic - The self-cancelling function is on. The direction indicators will activate for eight seconds and an additional 65 metres.
 - Auto Advanced - The self-cancelling function is on. A short press activates the direction indicators for three flashes. A longer press activates the direction indicators for eight seconds and an additional 65 metres.
 - Manual - The self-cancelling function is off. The direction indicators must be manually cancelled using the direction indicator switch.
- Press the joystick centre to confirm the required selection.
- The display will then return to the Bike Setup menu.

Instruments

Bike Setup - Traction Control (TC)

It is possible to temporarily disable the traction control system. The traction control cannot be permanently disabled, it will be automatically enabled when the ignition is turned off and then on again, or if the default riding mode is activated by a long press of the MODE button.

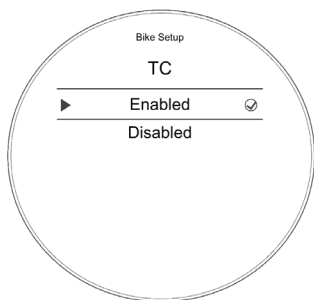

To select the required option:

- From the Bike Setup menu, push the joystick down to select TC and press the joystick centre to confirm.
- Push the joystick down/up to scroll between Enabled and Disabled.
- Press the joystick centre to select the required option.
- The display will then return to the Bike Setup display.

Bike Setup - Service

The service interval is set to a distance and/or time period.

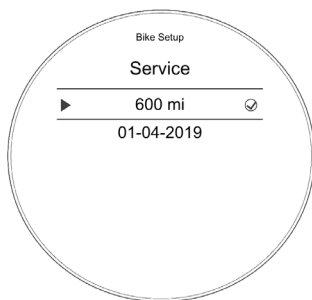

To review the service interval:

- From the Bike Setup menu, push the joystick down to select Service and press the joystick centre to confirm.
- The service time and distance information are then shown.

Bike Setup - Hill Hold Control (if fitted)

Hill hold control assists in making hill starts. The system (when activated) will apply the rear brake to hold the motorcycle in position. The system will then automatically deactivate and release the rear brake when it detects that the motorcycle is attempting to move off.



To enable/disable hill hold control:

- from the Bike Set Up menu, push the joystick down to select Hill Hold and press the joystick centre to confirm.
- Push the joystick down to select either Enabled or Disabled.
- Press the joystick centre to confirm the required selection.
- The display will then return to the Bike Set Up menu.

For more information on hill hold control, see page 103.

Bike Setup - TSA (Shift Assist) (if fitted)

Triumph Shift Assist (TSA) triggers a momentary engine torque change to allow gears to engage without closure of the throttle or operation of the clutch. This feature works for both up shift and down shift of gears.

The clutch must be used for stopping and pulling away.

TSA will not operate if the clutch is applied or if an up shift is attempted by mistake when in 6th gear. It is necessary to use a positive pedal force to make sure there is a smooth gear change.



To enable/disable TSA:

- From the Bike Set Up menu, push the joystick down to select TSA (Shift Assist) and press the joystick centre to confirm.
- Push the joystick down/up to select either Enabled or Disabled.
- Press the joystick centre to confirm the required selection.
- The display will then return to the Bike Set Up menu.

For more information on Triumph Shift Assist (TSA), see page 96.

Instruments

Trip Setup Menu

The Trip Setup menu allows configuration of the trip meters. Each trip meter can be configured to be reset either manually or automatically. The setup procedure is the same for both trip meters.

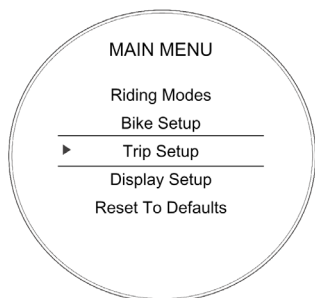

To access the Trip Setup menu:

- Press the HOME button to display the Main menu.
- Push the joystick down and then press the joystick centre to select Trip Setup.

The options available are:

- Trip 1 Reset
- Trip 2 Reset
- Trip 2 Display.

Trip Setup - Manual Reset

This menu allows the manual reset of each trip meter individually.

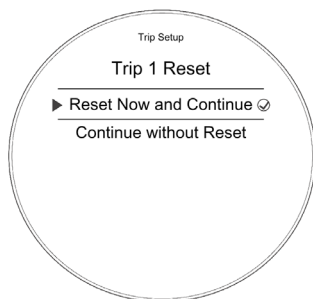

To set a trip meter manually:

- Push the HOME button to display the Main Menu.
- Push the joystick down and then press the joystick centre to select Trip Setup.
- Push the joystick down and then press the joystick centre to select either Trip 1 Reset or Trip 2 Reset.
- Push the joystick centre to select Manual.

There are two options available:

- Reset Now and Continue - Resets all trip meter data in the relevant trip meter.
 - Continue without Reset - The trip meter will not be reset.
- Press the joystick centre to confirm the selection and return to the previous menu.

Trip Setup - Automatic Reset

This menu allows the automatic reset of a trip meter after the ignition has been switched off for a set time.

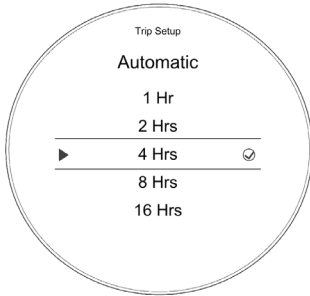

To set the trip meters to automatically reset:

- Push the HOME button to display the Main Menu.
- Push the joystick down and then press the joystick centre to select Trip Setup.
- Push the joystick down/up and then press the joystick centre to select Trip 1 Reset or Trip 2 Reset.
- Push the joystick down/up and select Automatic and then press the joystick centre.
- Push the joystick down/up to select the required timer setting and press the joystick centre to confirm the required time limit. The required time limit is then stored in the trip memory.

When the ignition is turned off, the trip meter is set to zero when the time period has elapsed.

The following table shows two examples of the automatic trip reset functionality.

Ignition Turned Off	Selected Time Delay	Trip Meter Resets to Zero
10:30 hrs	4 Hrs	14:30 hrs
18:00 hrs	16 Hrs	10:00 hrs (next day)

Trip 2 Enable/Disable

This menu allows Trip 2 meter to be enabled or disabled. If Trip 2 is disabled it will no longer be shown in the instrument display.

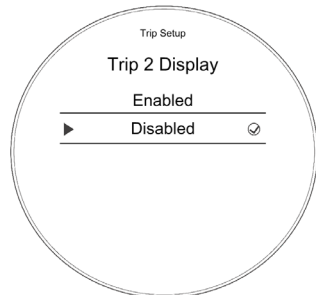

To enable or disable the Trip 2 meter:

- Push the MODE button to display the Main Menu.
- Push the joystick down to select Trip Setup.
- Push the joystick centre to display the Trip Setup menu.
- Push the joystick down/up to scroll to the Trip 2 Display and press the joystick centre.
- Push the joystick down/up to scroll between Enabled and Disabled and press the joystick centre.

Instruments

Display Setup Menu

From the Main menu, select Display Setup and push the joystick button to confirm.

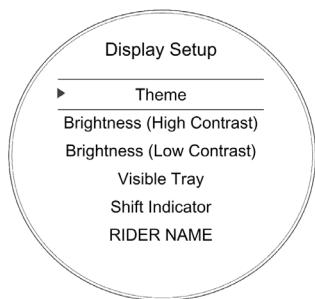

The Display Setup menu allows access to the following options:

- Theme
- Brightness (High Contrast)
- Brightness (Low Contrast)
- Visible Tray
- Shift Indicator
- Rider Name
- Language
- Units
- Clock
- Date.

Display Setup - Themes

To select a different theme:

- From the Display Setup menu, push the joystick centre to display the Theme menu.

- Press the joystick centre to select the required theme.

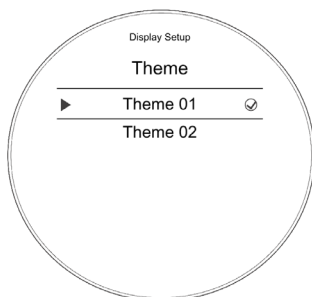

The new theme will be shown and saved. Press the HOME button to exit.

Display Setup - Brightness

The brightness feature allows the screen's brightness contrast to be changed for day time and night time riding.

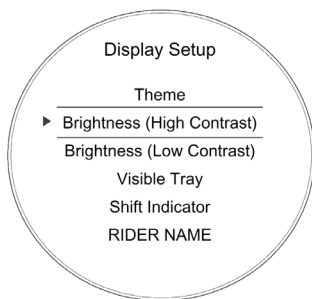

There are two brightness options to choose from; High Contrast and Low Contrast.

To change the brightness level:

- From the Display Setup menu, push the joystick down to select Brightness (High Contrast) or Brightness (Low Contrast).

- Push the joystick centre to confirm.
- Push the joystick down/up to adjust the brightness.
- Press the joystick centre to confirm the required level of brightness.
- Press the HOME button to return to the main display.

Note

In bright sunlight, the brightness settings will adapt to make sure that the instruments can be viewed at all times.

Display Setup - Visible Tray

The Visible Tray feature allows the selection of required information tray items to be shown in the instrument panel display.

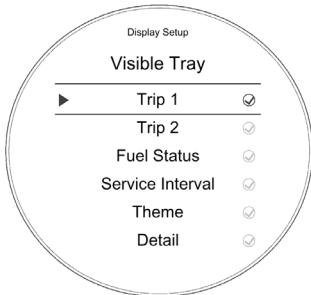

To select the Visible Tray menu:

- From the Display Setup menu, push the joystick down to select Visible Tray and press the joystick centre to confirm.
- Push the joystick down/up until the required information tray item is selected.

- Press the joystick centre to select/deselect the information tray item.

The options include:

- Trip 1
 - Trip 2
 - Fuel Status
 - Service Interval
 - Theme
 - Detail
 - Contrast
 - Coolant.
- An information tray item with a tick next to it will be shown in the instrument panel display. An information tray item without a tick next to it will not be shown in the instrument panel display.

Display Setup - Shift Indicator

This menu allows the adjustment of the gear shift indicator.

The gear shift indicator changes the tachometer colour to orange when the specified engine speed threshold is reached, indicating to change gear.

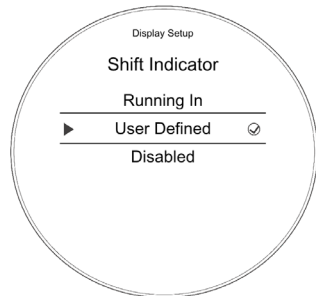

Instruments

The engine speed threshold can be defined and reset, and the gear shift indicator can be disabled. Once the engine has been run in (at 1,000 miles), the Running In option is replaced with a Default option.

From the Shift Indicator menu, push the joystick down to select User Defined and press the joystick centre to confirm.

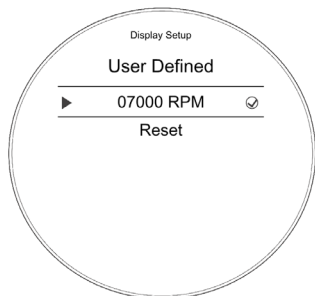

To adjust the engine speed threshold (RPM) for the gear shift indicator:

- Push the joystick left/right to select each individual number.
- Push the joystick down/up to change the number.
- Press the joystick centre to confirm selection.
- Repeat this process with each individual number until the correct RPM number is shown.

To reset the gear shift indicator:

- Push the joystick down/up to select Reset and press the joystick centre to confirm. This resets the RPM to 07000.

Display Setup - Rider Name

This menu allows the rider name to be entered in to the instrument panel system and shown in the welcome/start up display screen.



To enter a rider's name:

- From the Display Setup menu, push the joystick down to select Rider Name and press the joystick centre to confirm.
- Using the joystick, navigate the keyboard and select the first letter of the rider's name. Press the joystick button to confirm. The letter appears at the top of the keyboard.
- Repeat the procedure until the whole rider name has been selected. There is a character limit of 13 characters.
- Selecting "?123" shows a new keyboard of symbols and numbers to select from.
- Once the rider's name has been completed, select Enter and click on the joystick button to confirm.
- The rider's name will now appear on the welcome screen the next time the instruments are started.

Display Setup - Language

There are several different languages that can be selected to be shown in the instrument display screen.

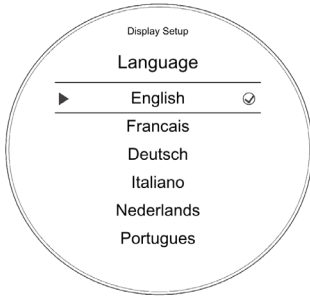

To select a different language:

- From the Display Setup menu, push the joystick down to select Language and press the joystick centre to confirm.
- Push the joystick down/up until the required language is selected.

The following options are available:

- English
 - French
 - German
 - Italian
 - Dutch
 - Portuguese
 - Spanish
 - Swedish.
- Press the joystick centre to select/deselect the required language.

Display Setup - Units

There are different units of measurement options that can be shown in the display screen.

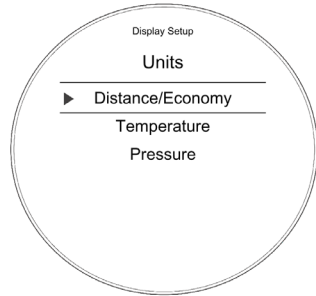

To select the units of measurement required:

- From the Display Setup menu, push the joystick down to select Units and press the joystick centre to confirm.
- Push the joystick down/up to select the required unit; Distance/Economy, Temperature or Pressure.

Instruments

- Push the joystick down/up to select the required unit of measurement from the following options:
 - **Distance/Economy:**
 - Miles and MPG (UK)
 - Miles and MPG (US)
 - KM and L/100KM
 - KM and KM/L
 - **Temperature:**
 - °C
 - °F
 - **Pressure:**
 - PSI
 - Bar
 - KPa
- Press the joystick centre to confirm.
- Push the joystick down/up to select between either 12 Hr or 24 Hr clock and press the joystick centre to confirm selection. The clock will display in either 12 or 24 hour format. Once the clock format is set the display will return to the Clock menu.

To set the time, push the joystick down/up to select Hours or Minutes.

To adjust the hour setting:

- Select Hours on the display and press the joystick centre, a tick will appear next to Hours and the hours display will flash as shown below.
- Push the joystick down/up to set the hour and press the joystick centre to confirm.

To adjust the minute setting:

- Select Minutes on the display and press the joystick centre, a tick will appear next to Minutes and the minutes display will flash as shown below.
- Push the joystick down/up to set the correct minute and press the joystick centre to confirm.

Display Setup - Clock

This function allows the adjustment of the clock.

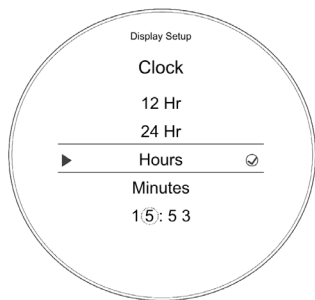

To set the clock:

- From the Display Setup menu, push the joystick down to select Clock and press the joystick centre to confirm.
- From the Display Setup menu, push the joystick down to select Date and press the joystick centre to confirm.

Display Setup - Date

This function allows the adjustment of the date and date format.

To set the date format:

- From the Display Setup menu, push the joystick down to select Date and press the joystick centre to confirm.

- Press the joystick centre to display Date Format.

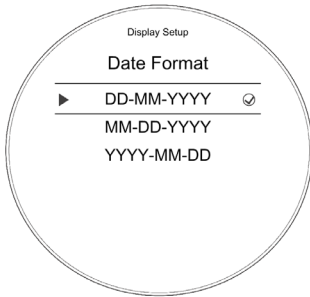

- Push the joystick down/up to select the required date format.

The following options are available:

- DD-MM-YYYY
- MM-DD-YYYY
- YYYY-MM-DD.

Press the joystick centre to confirm the selection. Once the date format is set the display will return to the Date menu.

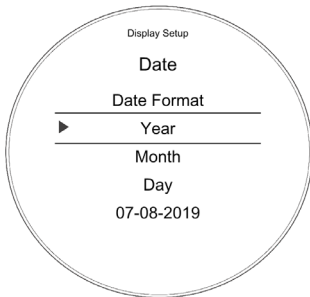

To set the date, push the joystick down/up to select the Year, Month and Day.

- Select Year and then press the joystick centre, a tick will appear next to the Year and the Year display will flash.
- Push the joystick down/up to set the current year and then press the joystick centre to confirm.
- To set the Month and Day repeat the procedure used to set the year. Once the date is set the display will return to the Date menu.

Reset to Defaults

This function allows the Main Menu items to be reset to the default setting.

To reset the Main Menu display:

- Press the HOME button to display the Main Menu.

Instruments

- Push the joystick down and then press the joystick centre to select Reset To Defaults.

The options are:

- Confirm - The following main menu settings and data will be reset to the factory default values - Riding Modes, Indicator Setup, Trip Computers, Visible Trays, Language, Traction Control, Themes and Display Brightness.
- Cancel - The main menu settings and data will remain unchanged and the display will return to the previous level.

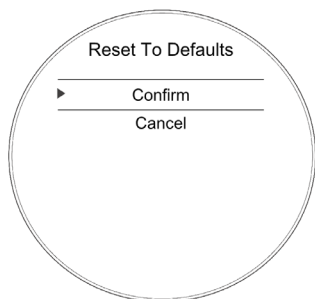

- Select the required option and press the joystick button to confirm.

Instrument Panel Position Adjustment

Warning

Operation of the motorcycle with an incorrectly adjusted instrument panel is dangerous.

An incorrectly adjusted instrument panel will result in loss of instrument vision when riding and may cause a distraction leading to loss of control of the motorcycle and an accident.

Always adjust the instrument panel to provide sufficient vision of the instruments before riding the motorcycle.

Warning

Never attempt to clean or adjust the instrument panel while riding the motorcycle. Removal of the rider's hands from the handlebar while riding the motorcycle will diminish the ability of the rider to maintain control of the motorcycle.

Attempting to clean or adjust the instrument panel while riding the motorcycle may result in loss of control of the motorcycle and an accident.

Only attempt to clean or adjust the instrument panel while stationary.

Caution

Do not press directly onto the instrument panel display screen.

Only adjust the position of the instrument panel using the adjustment lever.

Pressing directly on the instrument panel display screen may damage the instrument panel.

To adjust the instrument panel:

- Using the lever, move the instrument panel to allow an unobstructed view of the display screen.

Note

Moderate force using the thumb and finger is required to adjust the position of the instrument panel.

The instrument panel can be adjusted to allow for improved visibility of the display screen.

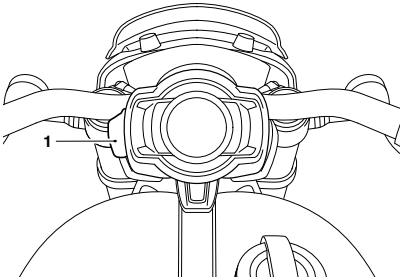

1. **Adjustment lever**

This page intentionally left blank

General Information

Table of Contents

Keys.....	61
Smart Key.....	61
Standard Key.....	63
Keyless Ignition.....	63
Master Ignition Switch (if fitted).....	64
Right Handlebar Switches.....	65
Hazard Warning Lights Button.....	65
Steering Lock Button.....	65
Power ON/OFF Position.....	65
STOP Position.....	65
RUN Position.....	66
QUICK START Position.....	66
HOME Button.....	66
Left Handlebar Switches.....	66
Cruise Control Adjust Button.....	66
Daytime Running Lights (DRL) Switch (if fitted).....	66
MODE Button.....	67
Direction Indicator Switch.....	67
Joystick Button.....	68
Horn Button.....	68
Heated Grips Switch (if fitted).....	68
High Beam Button.....	68
Throttle Control.....	69
Brake Use.....	70
Brake and Clutch Lever Adjusters.....	70
Cruise Control.....	71
Activating Cruise Control.....	72
Deactivating Cruise Control.....	72
Traction Control (TC).....	73
Optimised Cornering Traction Control.....	73
Traction Control Settings.....	74

General Information

Tyre Pressure Monitoring System (TPMS) (if fitted)	75
Tyre Pressure Sensor Serial Number	75
TPMS System Display	76
Sensor Batteries	76
TPMS System Fault	77
Tyre Pressures	77
Low Tyre Pressure	78
Fuel	78
Fuel Tank Cap	80
Filling the Fuel Tank	80
Side Panels	81
Seats	82
Seat Lock	82
Rider Seat	82
Rider and Passenger Seat	83
Seat Options	84
Seat Backrest (if fitted)	84
Seat Cover	85
Storage Compartment	85
Passenger Footrests	86
Side Stand	87
Windscreen (if fitted)	88
Tool Kit and Owner's Handbook	89
Electrical Accessory Socket	89
Universal Serial Bus (USB) Socket	90
Running-In	91
Daily Safety Checks	92

Keys

There are three keys supplied with the motorcycle. One smart key and two standard keys.

Warning

Additional keys, key rings/chains or items attached to the key may interfere with the steering, leading to loss of motorcycle control and an accident.

Remove all additional keys, key rings/chains and items from the key before riding the motorcycle.

Caution

Additional keys, key rings/chains or items attached to the key may cause damage to the motorcycle's painted or polished components.

Remove all additional keys, key rings/chains and items from the key before riding the motorcycle.

Caution

The motorcycle must not be ridden with the key in the seat lock.

Always lock the seat and remove the key before riding the motorcycle.

Caution

Do not store the spare key with the motorcycle as this will reduce all aspects of security.

Smart Key

There is one smart key supplied with the motorcycle.

Caution

All keys supplied with the motorcycle are specific to the individual motorcycle. They cannot be used on another motorcycle.

If all keys are lost, misplaced or damaged, then the chassis control unit on the motorcycle will need to be replaced.

To avoid unnecessary cost and time, make sure that all spare keys are kept in a secure location.

Caution

If there is a fault with the smart key or the smart key battery is flat then take the smart key to the nearest Triumph dealer to rectify.

General Information

Note

An additional smart key can be purchased from your Triumph dealer. However, only three keys can be programmed to the motorcycle. This can be a combination of smart keys and standard keys.

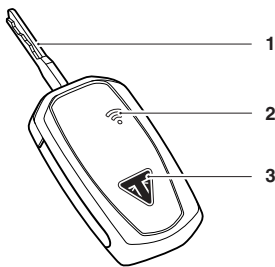

1. Smart key blade
2. Status symbol
3. ON/OFF button

The smart key operates the keyless ignition system. The smart key blade operates the seat lock, steering lock and fuel tank cap.

Note

For security reasons, the smart key should be switched off every time it is removed from the motorcycle.

Smart Key Battery Replacement

Warning

There is a risk of explosion if an incorrect battery is used.

Always make sure that the correct battery size and type is used.

Warning

Batteries contain harmful materials.

Always keep batteries out of the reach of infants and young children to prevent them being swallowed.

If swallowed, consult a doctor immediately.

Caution

Do not touch the contact sides of the battery with your skin. Only touch the edges of the battery when you hold it.

The natural materials in your skin can cause corrosion and shorten the life of the battery.

To replace the smart key battery:

- Make sure that the smart key is in passive mode (red LED).
- Remove the battery cover fixing using a 1.5 mm AF Allen key.
- Remove the battery cover.
- Remove the battery, noting its orientation.
- Insert a new 3 Volt CR2032 Lithium battery.
- Replace the battery cover making sure that it aligns correctly.
- Refit the battery cover fixing and tighten to 0.3 Nm.

Battery Disposal

The used battery must be handed to a recycling agent who will make sure that the dangerous substances from which the battery is manufactured do not pollute the environment.

Standard Key

There are two standard keys supplied with the motorcycle. The standard key operates the seat lock, steering lock and the fuel tank cap.

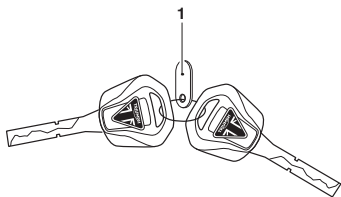

1. Key number tag

They have a small tag attached to them bearing the key number. Make a note of the key number and store the spare key and key number tag in a safe place away from the motorcycle. Always get replacement keys from your authorised Triumph dealer.

Keyless Ignition

The keyless ignition system allows the motorcycle to be started without the use of a mechanical key.

Smart Key Operation

To turn the motorcycle on with the keyless ignition:

- The smart key must be within close proximity (one metre/three feet) of a system sensor. There is a system sensor located on the left hand side of the motorcycle, and another system sensor located at the front of the motorcycle. If the smart key is out of range of a system sensor then it will be unresponsive and the keyless ignition cannot be activated.
- Press the button on the smart key to turn the key on. The button light shows green briefly to indicate that the smart key is on.

A short press on the smart key button shows the status of the smart key; red is OFF and green is ON.

A long press of the button will change the status to OFF or ON after briefly showing the original status colour first.

- If the smart key battery is flat, then use the smart key in the standard key operation method.

For more information on starting the engine with keyless ignition, see page 94.

General Information

Standard Key Operation

To turn the motorcycle on with the standard key (or the smart key if the battery is discharged):

- Hold the standard key on the system sensor located on the left hand side of the motorcycle.

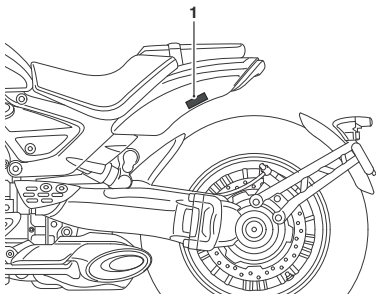

1. System sensor location

- The standard key must be held against the system sensor while pressing the Engine Start/Stop switch in either the QUICK START or Power ON/OFF position (see page 65).

Master Ignition Switch (if fitted)

The master ignition switch is only fitted to motorcycles in the United States and Canada. The master ignition switch is located on the left hand side of the motorcycle.

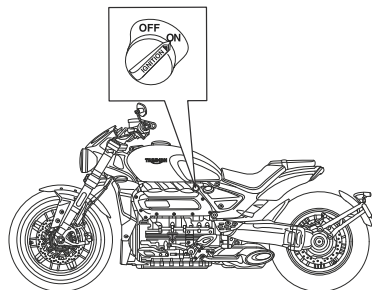

Master Ignition Switch

To operate the motorcycle with the keyless ignition, the master ignition switch must be in the ON position.

If the master ignition switch is in the OFF position then the keyless ignition cannot be used and the motorcycle can not be started.

Right Handlebar Switches

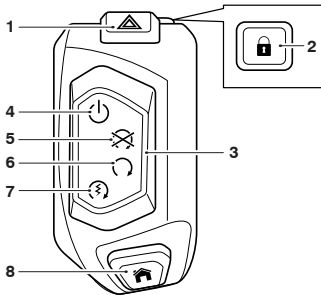

1. Hazard warning lights button
2. Steering lock button
3. Engine start/stop switch
4. Power ON/OFF position
5. STOP position
6. RUN position
7. QUICK START position
8. HOME button

Hazard Warning Lights Button

To turn the hazard warning lights on or off, press and release the hazard warning light button.

The ignition must be switched on for the hazard warnings lights to be activated, but the hazard lights will remain active if the ignition is switched off until the hazard warning light button is pressed again.

Steering Lock Button

To lock the motorcycle, turn the handlebar fully to the left and press the steering lock button.

Warning

For reasons of security and safety, always make sure the steering lock is on when leaving the motorcycle unattended.

Any unauthorised use of the motorcycle may cause injury to the rider, other road users and pedestrians and may also cause damage to the motorcycle.

Power ON/OFF Position

The Power ON/OFF position switches the electrical circuits and the instrument display between on or off. This allows access to the instrument display without starting the engine.

Caution

Do not leave the switch in the Power ON position for a long period of time as this may cause damage to electrical components and will discharge the battery.

STOP Position

The STOP position stops the engine.

Note

Although the engine stop position stops the engine, it does not turn off all the electrical circuits and may cause difficulty in restarting the engine due to a discharged battery.

General Information

RUN Position

The engine start/stop switch must be in the RUN position for the motorcycle to operate.

QUICK START Position

The QUICK START position operates the electric starter allowing for a quicker ignition start.

From the ignition off, press and hold the engine start/stop switch in the QUICKSTART position with all the correct conditions met, to start the motorcycle.

For more information, see page 94.

HOME Button

The HOME button is used to access the main menu on the instrument display.

Press and release the HOME button to select between the main menu and instrument display.

Left Handlebar Switches

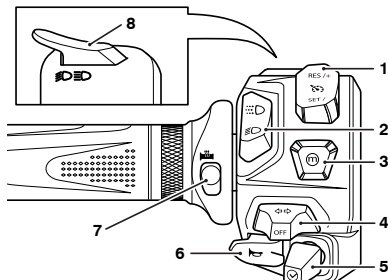

1. Cruise control adjust switch
2. Daytime Running Lights (DRL) switch (if fitted)
3. MODE button
4. Direction indicator switch
5. Joystick button
6. Horn button
7. Heated grips switch
8. High beam button

Cruise Control Adjust Button

The cruise control adjust button is a two way switch with the top marked RES/+ and the bottom marked SET/-.

For more information on cruise control operation, see page 71.

Daytime Running Lights (DRL) Switch (if fitted)

When the ignition is switched ON and the daytime running lights switch is set to DRL mode, the daytime running lights warning light will illuminate.



The daytime running lights and low beam headlights are operated manually using the DRL switch. Press the top of the switch for DRL mode, and the bottom of the switch for low beam headlight mode.

Warning

Do not ride for longer than necessary in poor ambient light conditions with the Daytime Running Lights (DRL) in use.

Riding with the daytime running lights when dark, in tunnels or where poor ambient light is apparent may reduce the riders vision or dazzle other road users.

Dazzling other road users or reduced vision in low ambient light levels may result in loss of motorcycle control and an accident.

Note

During daylight hours the daytime running lights improve the motorcycles visibility to other road users.

Low beam headlights must be used in any other conditions unless the road conditions allow for high beam headlights to be used.

MODE Button

When the MODE button is pressed and released it will activate the Riding Mode Selection Menu in the display screen. Further presses of the MODE button will scroll through the available riding modes, see Riding Mode Selection on page 32.

Press and hold the MODE button when a riding mode is selected provides direct access to the riding mode's configuration menu.

For more information on riding mode selection and configuration, see page 43.

Direction Indicator Switch

When the indicator switch is pushed to the left or right and released, the corresponding direction indicators will flash on and off. To turn off the indicators, push and release the switch in the central position.

Models Equipped with Automatic Self-Cancelling Indicators

A short press and release of the indicator switch to the left or right will cause the corresponding direction indicators to flash on and off three times, then go off.

A longer press and release of the indicator switch to the left or right will cause the corresponding direction indicators to flash on and off.

The indicators are automatically turned off after eight seconds and after riding a further 65 metres.

To disable the indicator self-cancel system refer to the Bike Setup section on page 45.

The indicators can be cancelled manually. To manually turn off the indicators, press and release the indicator switch in the central position.

General Information

Joystick Button

The Joystick is used to operate the following functions of the instruments:

- Up - scroll the menu from the bottom to the top
- Down - scroll the menu from the top to the bottom
- Left - scroll the menu to the left
- Right - scroll the menu to the right
- Centre - press to confirm selection.

Horn Button

When the horn button is pushed, with the ignition switch turned to the ON position, the horn will sound.

Heated Grips Switch (if fitted)

The heated grips will only heat when the engine is running.

When the heated grips are switched on, the heated grips symbol will appear in the display and the selected heat level will be shown.

There are three levels of heat: low, medium and high. This is indicated by the different colours of the symbols shown in the display.

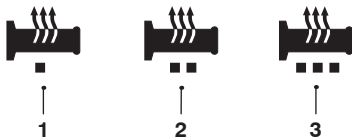

1. Low heat symbol (yellow)
2. Medium heat symbol (orange)
3. High heat symbol (red)

For maximum benefit in cold conditions, from the OFF position press the switch once for the high heat setting initially and then reduce the heat level by pressing the switch again for a low heat setting when the grips have warmed up.

To turn off the heated grips, press and release the switch until the heated grips symbol is no longer shown in the display.

Low Power Voltage Cut Off

If a low voltage is detected, the heated grips switch will power off. The heated grips will not function again until the voltage rises to a safe level.

The switch will not power back on automatically even if the voltage rises to the safe level. The user must manually press the switch again to activate the heated grips.

High Beam Button

The high beam button has a different function depending on whether Daytime Running Lights (DRL) are fitted or not. When the high beam is turned on, the high beam indicator light will illuminate in the display.

Models with Daytime Running Lights (DRL)

If the DRL switch is in the Daytime Running Lights (DRL) position, then press and hold the high beam button to turn the high beam on. It will remain on as long as the button is held in and will turn off as soon as the button is released.

If the DRL switch is in the dip beam position, press the high beam button to switch the high beam on. Each press of the button will swap between dip and high beam.

Note

A lighting on/off switch is not fitted to this model. The rear light and licence plate light all function automatically when the ignition is turned to the ON position.

The headlight will function when the ignition is turned on and the engine is running.

Models without Daytime Running Lights (DRL)

Press the high beam button to switch the high beam on. Each press of the button will swap between dip and high beam.

Note

A lighting on/off switch is not fitted to this model. The position light, rear light and licence plate light all function automatically when the ignition is turned to the ON position.

The headlight will function when the ignition is turned on and the engine is running.

Throttle Control

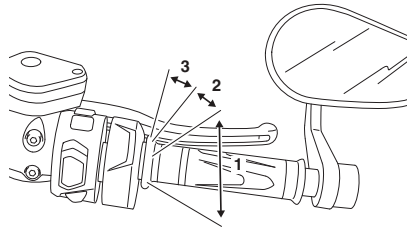

1. Throttle open position
2. Throttle closed position
3. Cruise control cancel position

This Triumph model has an electronic throttle twist grip to open and close the throttle via the engine control unit. There are no direct-acting cables in the system.

The throttle grip has a resistive feel to it as it is rolled rearwards to open the throttle. When the grip is released it will return to the throttle closed position by its internal return spring and the throttle will close.

From the closed position, the throttle twist grip can be rolled forward 3 - 4 mm to deactivate the cruise control (see page 72).

There are no user adjustments for the throttle control.

If there is a malfunction with the throttle control the Malfunction Indicator Light (MIL) becomes illuminated and one of the following engine conditions may occur:

- MIL illuminated, restricted engine RPM and throttle movement

General Information

- MIL illuminated, limp-home mode with the engine at a fast idle condition only
- MIL illuminated, engine will not start.

For all of the above conditions contact an authorised Triumph dealer as soon as possible to have the fault checked and rectified.

Brake Use

Warning

Reduce speed and do not continue to ride for longer than is necessary with the malfunction indicator light illuminated. The fault may adversely affect engine performance, exhaust emissions and fuel consumption.

Reduced engine performance could cause a dangerous riding condition, leading to loss of motorcycle control and an accident.

Contact an authorised Triumph dealer as soon as possible to have the fault checked and rectified.

At low throttle opening (approximately 20°), the brakes and throttle can be used together.

At high throttle opening (greater than 20°), if the brakes are applied for more than two seconds the throttles will close and the engine speed will reduce. To return to normal throttle operation, release the throttle control, release the brakes and then re-open the throttle.

Brake and Clutch Lever Adjusters

Warning

Do not attempt to adjust the levers with the motorcycle in motion as this may lead to loss of motorcycle control and an accident.

After adjusting the levers, operate the motorcycle in an area free from traffic to gain familiarity with the new lever setting.

Do not loan your motorcycle to anyone as they may change the lever setting from the one you are familiar with causing loss of motorcycle control and an accident.

An adjuster is fitted to both the front brake and clutch levers. The adjusters allow the distance from the handlebar to the lever to be changed to suit the span of the rider's hands.

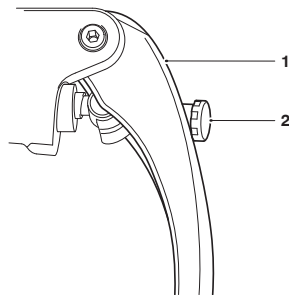

1. Brake lever shown
2. Adjusting screw

To adjust the lever:

- Push the lever forward and turn the adjusting screw in to increase the distance or out to shorten the distance from the handlebar.

Cruise Control

Warning

Cruise control must only be used where you can ride safely at a steady speed.

Cruise control should not be used when riding in heavy traffic, on roads with sharp/blind bends or when they are slippery.

Using cruise control in heavy traffic, on roads with sharp/blind bends or when they are slippery, may result in loss of motorcycle control and an accident.

Warning

This Triumph motorcycle should be operated within the legal speed limits for the particular road travelled.

Operating a motorcycle at high speeds can be potentially dangerous since the time available to react to given traffic situations is greatly reduced as road speed increases.

Always reduce speed in potentially hazardous driving conditions such as bad weather or heavy traffic.

Warning

Only operate this Triumph motorcycle at high speed in closed-course on-road competition or on closed-course racetracks.

High speed operation should only then be attempted by riders who have been instructed in the techniques necessary for high speed riding and are familiar with the motorcycle's characteristics in all conditions.

High speed operation in any other circumstances is dangerous and will lead to loss of motorcycle control and an accident.

Note

Cruise control may not function if there is a malfunction with the ABS system and the ABS warning light is illuminated.

The cruise control buttons are located on the left hand switch housing and can be operated with minimum movement by the rider.

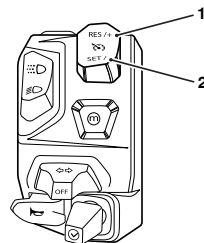

1. Cruise control RES/+ button
2. Cruise control SET/- button

General Information

Cruise control can be switched on or off at any time but it cannot be activated until all the conditions described on page 72 have been met.

Activating Cruise Control

The following conditions must be met to activate cruise control:

- The motorcycle must be travelling at a speed between 19 to 100 mph (30 to 160 km/h).
- The motorcycle must be in third gear or higher.

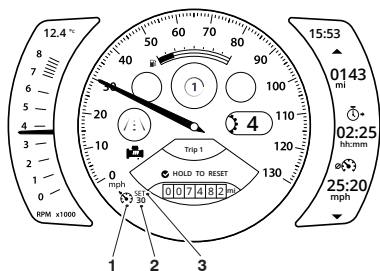

1. Cruise control symbol
2. Cruise control set indicator
3. Cruise control set speed

To activate cruise control:

- Press the cruise control button to turn the cruise control system on. The cruise control symbol will be shown in the display screen.
- When the required cruising speed is achieved, press the cruise control button again to activate the cruise control.
- The word SET will be shown next to the cruise control symbol. The cruise control set speed will then be shown.

- The cruise control system will maintain the set speed until the cruise control is deactivated as described on page 72.

Deactivating Cruise Control

The cruise control can be deactivated by one of the following methods:

- Roll the throttle twist grip fully forward.
- Pull the clutch lever.
- Operate the front or rear brake.
- Increase speed by using the throttle for more than 60 seconds.

Upon deactivation, the cruise control symbol will disappear but the SET indicator and set speed will still be shown in the display screen, indicating that the cruise control set speed has been stored.

Traction Control (TC)

Warning

The traction control and optimised cornering traction control systems are not a substitute for riding appropriately for the prevailing surface and weather conditions. The systems cannot prevent loss of traction due to:

- excessive speed when entering turns
- accelerating at a sharp lean angle
- braking.

Traction control or optimised cornering traction control cannot prevent the front wheel from slipping.

Failure to observe any of the above may result in loss of motorcycle control and an accident.

Warning

After riding off-road with traction control disabled, always make sure that the traction control is enabled when returning to ride on public roads.

Riding on public roads with the traction control disabled may, if accelerating too hard on wet/slippy road surfaces, cause the rear wheel to slip resulting in loss of motorcycle control and an accident.

All motorcycles are equipped with Traction Control (TC). Traction control is a system that helps to maintain traction when accelerating on wet/slippy road surfaces. If sensors detect that the rear wheel is losing traction (slipping), the traction control system will engage and alter the engine power until traction to the rear wheel has been restored.

The traction control indicator light will flash while it is engaged and there may be a change to the sound of the engine.

Optimised Cornering Traction Control

Warning

If the Traction Control (TC) system is not functioning, care must be taken when accelerating and cornering on wet/slippy road surfaces to avoid rear wheel spin.

In the event of a fault, the TC disabled warning light may be accompanied by the engine management system malfunction indicator light and/or the ABS warning light.

Do not continue to ride for longer than is necessary with any of the above warning lights illuminated. Contact an authorised Triumph dealer as soon as possible to have the fault checked and rectified.

Hard acceleration and cornering in this situation may cause the rear wheel to spin resulting in loss of motorcycle control and an accident.

General Information

Warning

If a fault occurs with the optimised cornering traction control system, the Traction Control (TC) disabled warning light will illuminate and a message will be shown in the display.

In this situation, the TC system will continue to operate but without the optimised cornering function, provided that:

- There are no other faults with the TC system.
- TC has NOT been disabled by the rider (see the Riding Modes Configuration section)

Care must be taken when accelerating and cornering on wet/slippery road surfaces to avoid rear wheel spin.

In the event of a fault, the TC disabled warning light may be accompanied by the engine management system malfunction indicator light and/or the ABS warning light.

Do not continue to ride for longer than is necessary with any of the above warning lights illuminated. Contact an authorised Triumph dealer as soon as possible to have the fault checked and rectified.

Hard acceleration and cornering in this situation may cause the rear wheel to spin resulting in loss of motorcycle control and an accident.

Note

Optimised traction control may not function if there is a malfunction with the ABS system. In this situation, the warning lights for the ABS, TC and the MIL may be illuminated.

Optimised cornering traction control is a system designed to give the rider increased control should the traction control be activated whilst the motorcycle is leaning in a corner.

The system constantly monitors the lean angle of the motorcycle and adapts the level of traction control intervention to maintain rear wheel traction during cornering.

For full details of the TC disabled warning light operation and its associated instrument warning messages, see page 27.

Traction Control Settings

Warning

If the traction control is disabled, the motorcycle will handle as normal but without traction control.

In this situation accelerating too hard on wet/slippery road surfaces may cause the rear wheel to slip, and may result in loss of motorcycle control and an accident.

The TC system can be disabled as described in Bike Setup on page 46, or set to the conditions described in Riding Mode Configuration on page 43.

Tyre Pressure Monitoring System (TPMS) (if fitted)

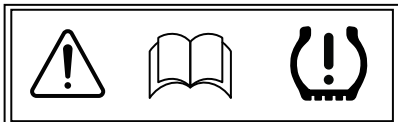

Warning

The daily check of tyre pressures must not be excluded because of the fitment of the Tyre Pressure Monitoring System (TPMS).

Check the tyre pressure when the tyres are cold using an accurate tyre pressure gauge, see the Tyre section for more information.

Use of the TPMS system to set inflation pressures may lead to incorrect tyre pressures leading to loss of motorcycle control and an accident.

Note

The Tyre Pressure Monitoring System (TPMS) is available as an accessory kit. It must be fitted by your authorised Triumph dealer.

The TPMS display on the instruments will only be activated when the system has been fitted.

Function

Tyre pressure sensors are fitted to the front and rear wheels. These sensors measure the air pressure inside the tyre and transmit pressure data to the instruments. The sensors will not transmit data until the motorcycle reaches a speed of approximately 12 mph (20 km/h). Two dashes will be visible in the system display until the tyre pressure signal is received.

After bring the motorcycle to a stop, the sensors continue to transmit data for approximately seven minutes before switching off. The tyre pressure values remain visible in the system display until the sensors switch off.

An adhesive label will be fitted to the wheel rim to indicate the position of the tyre pressure sensor, which is near the valve.

Tyre Pressure Sensor Serial Number

The serial number for the tyre pressure sensor is printed on a label attached to the sensor. This number may be required by your authorised Triumph dealer for service or diagnostics.

When the tyre pressure monitoring system is being fitted to the motorcycle, make sure that your authorised Triumph dealer records the serial numbers of the front and rear tyre pressure sensors in the spaces provided below.

Front Tyre Pressure Sensor

General Information

Rear Tyre Pressure Sensor



TPMS System Display



The tyre pressure warning light works in conjunction with the Tyre Pressure Monitoring System (TPMS).

The warning light will illuminate when the front or rear tyre pressure is below the recommended pressure. It will not illuminate if the tyre is over inflated.

When the warning light is illuminated, the TPMS symbol indicating which is the deflated tyre and its pressure will automatically be shown in the tyre pressure display.

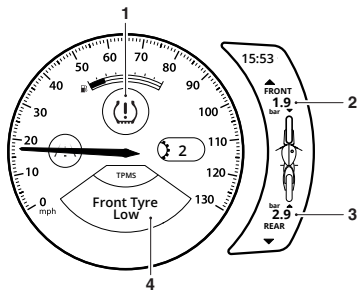

1. TPMS warning light
2. Front tyre pressure indicator
3. Rear tyre pressure indicator
4. TPMS information tray message

The tyre pressure at which the warning light illuminates is temperature compensated to 20°C but the numeric pressure display associated with it is not. Even if the numeric display seems at or close to the standard tyre pressure when the warning light is on, a low tyre pressure is indicated and a puncture is the most likely cause.

Warning

Stop the motorcycle if the tyre pressure warning light illuminates.

Do not ride the motorcycle until the tyres have been checked and the tyre pressures are at their recommended pressure when cold.

The information display will automatically switch to the tyre pressure display when a low tyre pressure is detected.

Dashes will be shown in the tyre pressure display until the motorcycle reaches a speed of approximately 12 mph (20 km/h).

Sensor Batteries

When the battery voltage in a pressure sensor is low, the TPMS symbol will be shown in amber and a message will indicate which wheel sensor has the low battery voltage.

If the batteries are completely flat, only dashes will be shown in the display screen and the red TPMS warning light will be on. A message will also be shown in the display.

Contact your authorised Triumph dealer to have the sensor replaced and the new serial number recorded in the spaces provided on page 75.

With the ignition switched on, if the TPMS symbol flashes continuously or the TPMS warning light remains on there is a fault with the TPMS system. Contact your Triumph dealer to have the fault rectified.

TPMS System Fault

If a fault occurs with the TPMS system, the TPMS warning light will be illuminated red to indicate that the system can't show the pressure or the pressure is low. If the TPMS warning light illuminates amber then that indicates that the battery is low but the pressure is available. A message will also be shown in the information tray. Contact your authorised Triumph dealer to have the fault rectified.

Tyre Pressures

Warning

The Tyre Pressure Monitoring System (TPMS) is not to be used as a tyre pressure gauge when adjusting the tyre pressures.

For correct tyre pressures, always check the tyre pressures when the tyres are cold using an accurate tyre pressure gauge.

Use of the TPMS system to set inflation pressures may lead to incorrect tyre pressures leading to loss of motorcycle control and an accident.

Caution

Do not use anti puncture fluid or any other item likely to obstruct air flow to the TPMS sensor's orifices. Any blockage to the air pressure orifice of the TPMS sensor during operation will cause the sensor to become blocked, causing irreparable damage to the TPMS sensor assembly.

Damage caused by the use of anti puncture fluid or incorrect maintenance is not considered a manufacturing defect and will not be covered under warranty.

Always have your tyres fitted by your authorised Triumph dealer and inform them that tyre pressure sensors are fitted to the wheels.

The tyre pressures shown on the instrument display indicate the actual tyre pressure at the time of selecting the TPMS. This may differ from the inflation pressure set when the tyres are cold because tyres become warmer during riding, causing the air in the tyre to expand and the inflation pressure to increase. The cold inflation pressures specified by Triumph take account of this.

Only adjust tyre pressures when the tyres are cold using an accurate tyre pressure gauge (see page 141), and do not use the tyre pressure shown on the instrument display.

General Information

Low Tyre Pressure

Warning

Stop the motorcycle if the tyre pressure warning light illuminates.

Do not ride the motorcycle until the tyres have been checked and the tyre pressures are at their recommended pressure when cold.

If a low tyre pressure is detected, the tyre pressure warning light will illuminate and a message will be shown in the display (see page 76).

Fuel

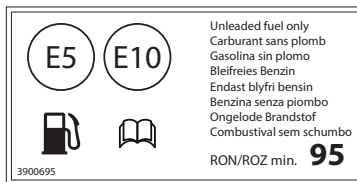

Fuel Grade

Triumph motorcycles are designed to use unleaded fuel and will give optimum performance if the correct grade of fuel is used. Always use unleaded fuel with a minimum octane rating of 95 RON.

Ethanol

In Europe, Triumph motorcycles are compatible with Ethanol E5 and E10 (5% and 10% Ethanol) unleaded fuel.

In all other markets Ethanol up to E25 (25% Ethanol) may be used.

Engine Calibration

In certain circumstances engine calibration may be required. Always refer to your authorised Triumph dealer.

Caution

The motorcycle can be permanently damaged if it is allowed to operate with the incorrect grade of fuel or incorrect engine calibration.

Always make sure the fuel used is of the correct grade and quality.

Damage caused by using the incorrect fuel or engine calibration is not considered a manufacturing defect and will not be covered under warranty.

Caution

The exhaust system for this motorcycle is fitted with a catalytic converter to help reduce exhaust emission levels.

Use of leaded fuel will damage the catalytic converter. In addition, the catalytic converter can be permanently damaged if the motorcycle is allowed to run out of fuel or if the fuel level is allowed to get very low.

Always make sure you have adequate fuel for your journey.

Refuelling

Warning

To help reduce hazards associated with refuelling, always observe the following fuel safety instructions:

- Petrol (fuel) is highly flammable and can be explosive under certain conditions. When refuelling, turn the ignition switch to the OFF position.
- Do not smoke.
- Do not use a mobile telephone.
- Make sure the refuelling area is well ventilated and free from any source of flame or sparks. This includes any appliance with a pilot light.
- Never fill the tank until the fuel level rises into the filler neck. Heat from sunlight or other sources may cause the fuel to expand and overflow creating a fire hazard.
- After refuelling always check that the fuel filler cap is correctly closed.
- Because petrol (fuel) is highly flammable, any fuel leak or spillage, or any failure to observe the safety advice given above will lead to a fire hazard, which could cause damage to property, injury to persons or death.

Note

The use of leaded fuel is illegal in some countries, states or territories.

General Information

Fuel Tank Cap

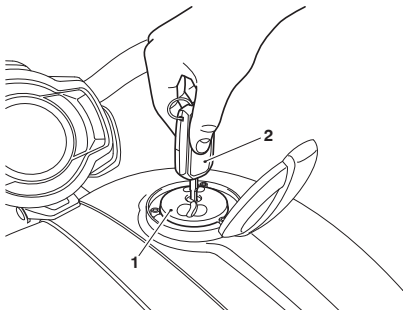

1. Fuel tank cap
2. Key

To open the fuel tank cap:

- Unhook the fuel tank cap cover.
- Lift up the fuel tank cap cover.
- Insert the key into the fuel tank cap lock.
- Hold the fuel tank cap in place and turn the key anticlockwise to unlock.
- Remove the key.
- Turn the fuel tank cap anticlockwise to release. Remove the fuel tank cap.

To close and lock the fuel tank cap:

- Replace the fuel tank cap and turn clockwise until the lock clicks into place.
- Insert the key into the fuel tank cap lock.
- Hold the fuel tank cap in place and turn the key clockwise to lock.
- Remove the key.
- Close the fuel tank cap cover making sure that it is firmly shut.

Filling the Fuel Tank

Warning

Overfilling the tank can lead to fuel spillage.

If fuel is spilled, thoroughly clean up the spillage immediately and dispose of the materials used safely.

Take care not to spill any fuel on the engine, exhaust pipes, tyres or any other part of the motorcycle.

Because fuel is highly flammable, any fuel leak or spillage, or any failure to observe the safety advice given above may lead to a fire hazard, which could cause damage to property and injury or death to persons.

Fuel spilled near to, or onto the tyres will reduce the tyres' ability to grip the road. This will result in a dangerous riding condition potentially causing loss of motorcycle control and an accident.

Caution

Avoid filling the tank in rainy or dusty conditions where airborne material can contaminate the fuel.

Contaminated fuel may cause damage to fuel system components.

Fill the fuel tank slowly to help prevent spillage. Do not fill the tank to a level above the bottom of the filler neck. This will make sure there is enough air space to allow for fuel expansion if the fuel inside the tank expands through absorption of heat from the engine or from direct sunlight.

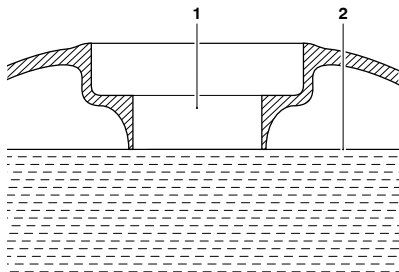

1. Fuel filler neck
2. Maximum fuel level

After refuelling always check that the fuel filler cap is correctly closed.

Side Panels

The right hand side panel can be removed to gain access to the tool kit and to adjust the rear rebound damping suspension.

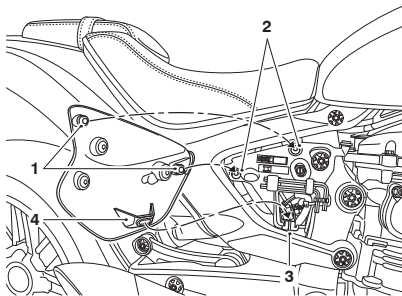

1. Spigots
2. Grommets
3. Side panel locating tang
4. Side panel locating slot

To remove the side panel:

- Grasp the panel firmly in both hands and gently pull the top edge of the panel away from the motorcycle until the upper spigots are away from the retaining grommets (leaving the grommets in place).
- Slide the side panel upwards and lift the side panel away from the side panel locating tang.

To refit side panel:

- Slide the side panel downwards while placing the side panel locating tang into the side panel locating slot.
- Position the upper spigots to the grommets.
- Press firmly to secure the panel.
- Grasp the panel and make sure that it is fully retained.

General Information

Seats

⚠ Caution

To prevent damage to the seats or seat covers, care must be taken not to drop the seats.

Do not lean the seats against the motorcycle or any surface which may damage the seats or seat covers. Instead, place the seats, with the seat cover facing upwards, on a clean, flat surface which is covered with a soft cloth.

Do not place any item on the seats which may cause damage or staining to the seat covers.

For seat cleaning information, see page 161.

Seat Lock

⚠ Warning

To prevent detachment of the seat during riding, after fitting always grasp the seat and pull firmly upwards.

If the seat is not correctly secured in the lock, it will detach from the lock.

A loose or detached seat may cause loss of motorcycle control and an accident.

⚠ Caution

The motorcycle must not be ridden with the key in the seat lock.

Always lock the seat and remove the key before riding the motorcycle.

The seat lock is located on the left hand side of the motorcycle, below the seat and near the oil filler cap.

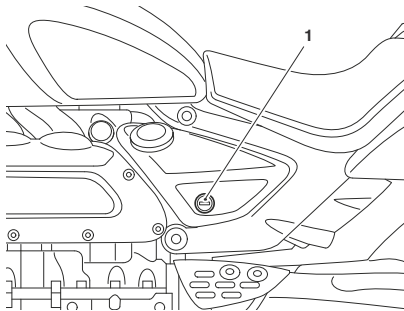

1. Seat lock

The seat can be removed to gain access to the battery, fuses, storage compartment and USB socket.

Rider Seat

⚠ Warning

To prevent detachment of the seat during riding, after fitting always grasp the seat and pull firmly upwards.

If the seat is not correctly secured in the lock, it will detach from the lock.

A loose or detached seat may cause loss of motorcycle control and an accident.

To remove the rider seat:

- Insert the ignition key into the seat lock and turn it anticlockwise while pressing down on the rear of the seat.
- This will release the rider seat from its lock.
- Lift the seat up from the rear, and slide the seat rearwards to remove it from the motorcycle.

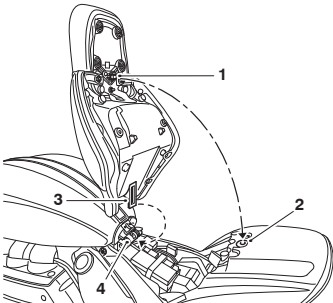

1. Locating peg
2. Locating peg lock
3. Seat bracket
4. Fuel tank hinge

To install the rider seat:

- Position the seat's front bracket under the fuel tank hinge.
- Align the locating peg to the lock.
- Press the seat down engaging the locating peg in the lock. An audible click can be heard when the seat is fully engaged.

Rider and Passenger Seat

Warning

To prevent detachment of the seat during riding, after fitting always grasp the seat and pull firmly upwards.

If the seat is not correctly secured in the lock, it will detach from the lock.

A loose or detached seat may cause loss of motorcycle control and an accident.

The rider and passenger seats are joined together to form one seat for ease of removal and installation.

To remove the rider and passenger seat:

- Insert the ignition key into the seat lock and turn it counterclockwise while pressing down on the rear of the seat.
- This will release the seat from its lock.
- Lift the seat up from the rear, and slide the seat rearwards to remove it from the motorcycle.

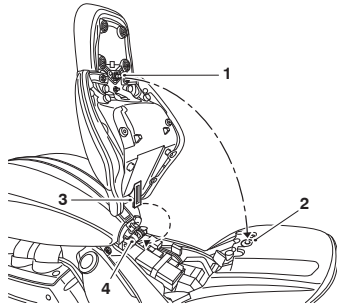

1. Locating peg
2. Locating peg lock
3. Seat bracket
4. Fuel tank hinge

General Information

To install the rider and passenger seat:

- Position the seat's front bracket under the fuel tank hinge.
- Align the locating peg to the lock.
- Press the seat down engaging the locating peg in the lock. An audible click can be heard when the seat is fully engaged.

Seat Options

There are several different combinations of rider and passenger seats available. A passenger seat can be fitted to the rider seat using the seat bracket. A rider infill section can also be fitted to the rider seat instead of a passenger seat. The attachment procedure is the same for a passenger seat or a rider infill section.

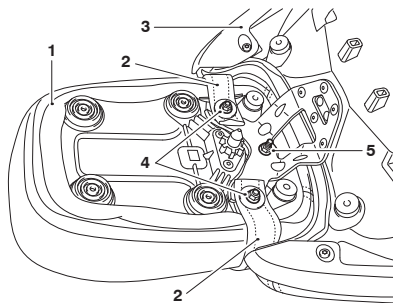

1. Passenger seat
2. Passenger seat straps
3. Rider seat
4. Seat washers and nuts
5. Main seat nut

To remove the passenger seat or rider infill section from the rider seat:

- Release the two seat washers and nuts that secure the seat strap in place, if fitted.
- Release the main seat nut.

- Remove the passenger seat or rider infill section.

To fit the passenger seat or rider infill section to the rider seat:

- Align the passenger seat or rider infill section to the seat bracket.
- Align the seat strap, if applicable.
- Fit the seat washers and nuts, attaching the seat strap, if applicable. Tighten the seat nuts to 3 Nm.
- Fit the main seat nut and tighten to 3 Nm.

Seat Backrest (if fitted)

Warning

To prevent detachment of the backrest during riding, after adjusting always grasp the backrest and pull firmly upwards.

If the backrest is not correctly secured in position, it will detach from its lock.

A loose or detached backrest may cause loss of motorcycle control and an accident.

The passenger seat backrest is adjustable.

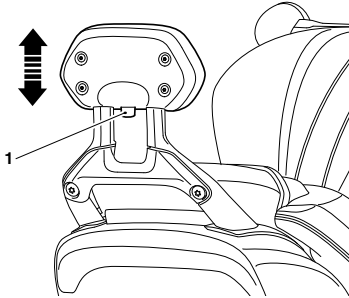

1. Backrest adjustment lever

To adjust the backrest:

- Push and hold the lever forward towards the front of the motorcycle.
- Move the backrest pad up or down to adjust the position for the passenger.
- Once the backrest is in the correct position, release the lever.

Seat Cover

A seat cover is provided with the motorcycle which protects the leather seat from rain, bird mess, tree sap, sun and frost. There is a seat cover for both the rider seat and the rider and passenger seat.

To fit the seat cover:

- Remove the seat from the motorcycle.
- The seat cover is contained within a small pouch. Remove the seat cover from the pouch.
- Fit the seat cover to the seat making sure that the Triumph logo on the seat cover is positioned at the rear of the seat.

- Make sure that the seat cover is fitted securely.
- Refit the seat to the motorcycle.

Storage Compartment

Caution

Loose and unsecured items in the storage compartment may get damaged or cause damage to the motorcycle.

Make sure there is sufficient space surrounding any electronic devices or other items for the storage compartment to close without causing any damage to the items or the motorcycle.

Secure all electronic devices, cables and any other items safely in the storage compartment before riding.

Caution

Always make sure that the storage compartment lid is closed securely before refitting the seat to prevent damage to the storage compartment lid.

There is a small storage compartment located underneath the seat towards the rear wheel. The storage compartment may be used to store electrical devices when using the USB socket, and small items when riding.

General Information

Passenger Footrests

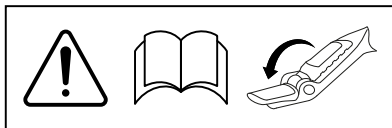

Warning

Always make sure that the passenger footrests are fully extended when carrying a passenger.

Never carry a passenger without him or her using the fully extended passenger footrests.

Incorrect foot placement anywhere on the motorcycle instead of using the footrests may cause:

- the passenger's feet or clothing to become entrapped
- the passenger to be in contact with hot exhaust pipes.

Incorrect foot placement anywhere on the motorcycle instead of using the footrests will cause:

- severe personal injuries to the passenger
- instability of the motorcycle that may cause an accident
- damage to the motorcycle
- damage to clothing.

Warning

Avoid trapping fingers and clothing when opening and closing the passenger footrests.

Always take care when using the passenger footrests to avoid personal injury and damage to clothing and the motorcycle.

Passenger Footrests

There are passenger footrests located on both sides of the motorcycle below the rider seat. They have been designed to close into the motorcycle when not in use.

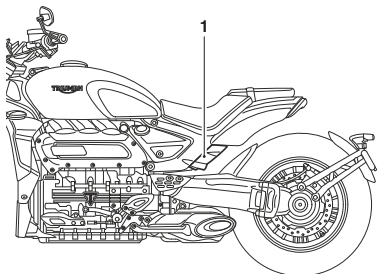

1. Passenger footrest section closed into motorcycle

To open the passenger footrests when closed into the motorcycle:

- From the top of the passenger footrest section, carefully pull the footrest section down and outwards until it stops in position.

- Lift upwards and extend out the footrest until it stops in position.

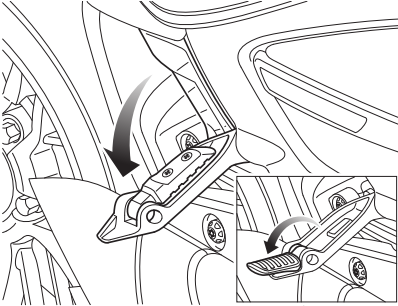

Using the Passenger Footrests

To close the passenger footrests into the motorcycle:

- Fold the footrest into the footrest section until it is firmly in place.
- Lift the folded footrest section up and push inward to the motorcycle until it is firmly in place.

Adjustable Footrests

This motorcycle is fitted with adjustable rider and passenger footrests that can be extended for a more comfortable footrest position. An extension socket is located under the left hand side panel in the tool kit, see page 89.

To adjust the footrests, it is recommended that the motorcycle is taken to a Triumph dealer to extend and adjust the footrests accordingly.

Side Stand

⚠ Warning

The motorcycle is fitted with an interlock system to prevent it from being ridden with the side stand in the down position.

Never attempt to ride with the side stand down or interfere with the interlock mechanism as this will cause a dangerous riding condition leading to loss of motorcycle control and an accident.

⚠ Warning

Do not lean, sit or climb on the motorcycle when it is supported on the side stand.

This may cause the motorcycle to fall over leading to motorcycle damage and an accident.

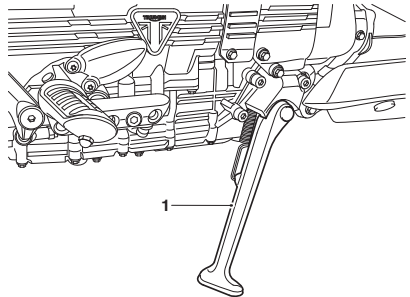

1. Side stand

General Information

The motorcycle is equipped with a side stand on which the motorcycle can be parked. When using the side stand, always turn the handlebars fully to the left and leave the motorcycle in first gear.

Before riding, always make sure that the side stand is fully up after first sitting on the motorcycle.

For instructions on safe parking, refer to the How to Ride the Motorcycle section.

Windscreen (if fitted)

Warning

Never attempt to clean the windscreen while riding the motorcycle.

Removal of the rider's hands from the handlebars while riding the motorcycle will diminish the ability of the rider to maintain the control of the motorcycle.

Attempting to clean the windscreen while riding the motorcycle may result in loss of motorcycle control and an accident.

For windscreen cleaning information, see page 163.

The windscreen is not adjustable.

Tool Kit and Owner's Handbook

Owner's Handbook

The Owner's Handbook is supplied separately.

Tool Kit

The tool kit is located behind the right side panel.

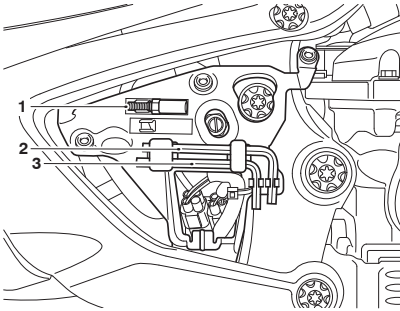

1. Extension socket for footrests, gear and brake pedals
2. 6 mm Allen key
3. 5 mm Allen key

To adjust the footrests, brake pedal or gear pedal, it is recommended that the motorcycle is taken to a Triumph dealer to adjust accordingly. The tool kit section allows the extra extension sockets to be stored securely.

Electrical Accessory Socket

Caution

Do not leave electrical accessories connected to the front electrical accessory socket when the engine is not running as this will discharge the battery.

An electrical accessory socket is provided on the motorcycle, located in front of the fuel tank.

The socket will provide a 12 Volt electrical supply and is permanently live.

The electrical accessory socket circuit is protected by the specified fuse shown in the fuse table in the Fuse section.

Note

To protect the battery from excessive discharge while using fitted electrical accessories, the combined total current which may be drawn through the electrical accessory sockets is five Amps.

A plug, suitable for use with the accessory socket, is available from your authorised Triumph dealer.

General Information

Universal Serial Bus (USB) Socket

Warning

The USB socket is not waterproof. Do not connect electronic devices whilst it is raining.

Water in the USB socket could lead to an electrical problem, resulting in motorcycle damage, loss of motorcycle control and an accident.

A Universal Serial Bus (USB) socket is provided, located in the storage compartment under the seat. The connector provides a 5 Volt, 2 Amp power supply which is suitable for charging electronic devices such as mobile phones, cameras and GPS devices.

To access the USB socket:

- Remove the seat.
- Open the storage compartment. The USB socket is located at the back of the storage compartment.
- Connect the device using a suitable USB cable, then store the device and USB cable in the space available in the storage compartment.

Caution

Make sure that all electronic devices and cables are safely secured under the seat when riding.

Make sure there is sufficient space surrounding any electronic devices for the seat to close without causing any damage to the electronic device or the motorcycle.

- Fit the seat, making sure that the device or USB cable is not trapped.
- Turn the ignition on and start the engine.

Caution

Do not leave the ignition switch in the ON position unless the engine is running as this will discharge the battery.

- When the device has finished charging, remove the seat and disconnect the device.
- Close the storage compartment and refit the seat.

Note

The USB socket is protected by a chassis ECM, which will automatically cut power to the socket in the event of an overload.

Power can be restored to the USB socket by turning the ignition switch off then on again, provided that the socket is not still overloaded.

Running-In



Running-in is the name given to the process that occurs during the first hours of a new vehicle's operation.

In particular, internal friction in the engine will be higher when components are new. Later on, when continued operation of the engine has ensured that the components have 'bedded in', this internal friction will be greatly reduced.

A period of careful running-in will ensure lower exhaust emissions, and will optimise performance, fuel economy and longevity of the engine and other motorcycle components.

During the first 600 miles (1000 km):

- Do not use full throttle;
- Avoid high engine speeds at all times;
- Avoid riding at one constant engine speed, whether fast or slow, for a long period of time;
- Avoid aggressive starts, stops, and rapid accelerations, except in an emergency;
- Do not ride at speeds greater than 3/4 of maximum speed.

From 600 to 1,000 miles (1000 to 1,500 km):

- Engine speed can gradually be increased to the rev limit for short periods.

Both during and after running-in has been completed:

- Do not overrev the engine when cold;
- Do not let the engine labour. Always downshift before the engine begins to 'struggle';
- Do not ride with engine speeds unnecessarily high. Changing up a gear helps reduce fuel consumption, reduces noise and helps to protect the environment.

General Information

Daily Safety Checks



Warning

Failure to perform these checks every day before you ride may result in serious motorcycle damage or an accident causing serious injury or death.

Check the following items each day before you ride. The time required is minimal, and these checks will help make sure you have a safe, reliable ride.

If any irregularities are found during these checks, refer to the Maintenance and Adjustment section or see your authorised Triumph dealer for the action required to return the motorcycle to a safe operating condition.

Check:

Fuel: Adequate supply in tank, no fuel leaks (see page 78).

Engine Oil: Correct level shown on dipstick. Add correct specification oil as required. No leaks from the engine or oil cooler (see page 119).

Final Drive: No oil leaks (see page 128).

Tyres/Wheels: Correct inflation pressures (when cold). Tread depth/wear, tyre/wheel damage, punctures etc. (see page 140).

Nuts, Bolts, Fasteners: Visually check that steering and suspension components, axles, and all controls are properly tightened or fastened. Inspect all areas for loose/damaged fixings.

Steering Action: Smooth but not loose from lock to lock. No binding of any of the control cables (see page 134).

Brakes: Pull the brake lever and push the brake pedal to check for correct resistance. Investigate any lever/pedal where the travel is excessive before meeting resistance, or if either control feels spongy in operation (see page 129).

ABS: Make sure that the ABS warning light does not remain illuminated at speeds above 6 mph (10 km/h) when moving off (see page 100).

Brake Pads: There should be more than 1.5 mm of friction material remaining on all the pads (see page 129).

Brake Fluid Levels: No brake and clutch fluid leakage. Brake fluid levels must be between the MAX and MIN marks on both reservoirs (see page 132).

Front Forks: Smooth action. No leaks from fork seals (see page 136).

Throttle: Throttle grip free play 2 - 3 mm. Make sure that the throttle grip returns to the idle position without sticking (see page 69).

Clutch Fluid Level: No brake and clutch fluid leakage. The clutch fluid level must be between the MAX and MIN marks on the reservoir (see page 127).

Coolant: No coolant leakage. Check the coolant level in the expansion tank (when the engine is cold) (see page 124).

Electrical Equipment: All lights and the horn function correctly (see page 63).

Engine Stop: Stop switch turns the engine off (see page 94).

Stand: Returns to the fully up position by spring tension. Return springs not weak or damaged (see page 87).

How to Ride the Motorcycle

Table of Contents

Stopping the Engine.....	94
Starting the Engine.....	94
Moving Off.....	95
Changing Gears.....	96
Triumph Shift Assist (TSA) (if fitted).....	96
Braking.....	97
Anti-lock Braking System (ABS).....	100
Optimised Cornering ABS.....	101
ABS Warning Light.....	102
Hill Hold Control.....	103
Activation.....	104
Deactivation.....	104
Hill Hold Unavailable.....	105
Parking.....	105
Considerations for High Speed Operation.....	107

How to Ride the Motorcycle

Stopping the Engine

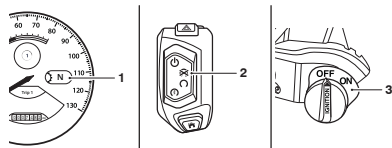

1. Neutral indicator light
2. Engine stop switch - STOP position
3. Master ignition switch - OFF position (if fitted)

To stop the engine:

- Close the throttle completely.
- Select neutral.
- Place the engine stop switch in the STOP position.
- Turn the master ignition switch to the OFF position (if fitted).
- Select first gear.
- Support the motorcycle on a firm, level surface with the side stand.
- Lock the steering.

Caution

Do not leave the ignition switched on with the engine stopped. This will cause electrical damage.

Starting the Engine

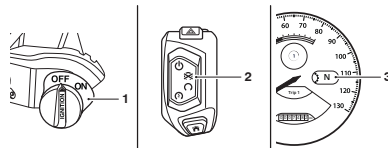

1. Master ignition switch (if fitted)
2. Engine start/stop switch - QUICK START position
3. Neutral indicator light

To start the engine:

- Make sure that the master ignition switch (if fitted) is turned to the ON position, see page 64.
- Pull the clutch lever fully into the handlebar.
- Press and hold the QUICK START position on the engine start/stop switch until the engine starts.
- Make sure that the transmission is in neutral.

The motorcycle is equipped with starter lockout switches. The switches prevent the electric starter from operating when the transmission is not in neutral with the side stand down.

If the side stand is extended whilst the engine is running, and the transmission is not in neutral then the engine will stop regardless of clutch position.

Warning

Never start the engine or run the engine in a confined area.

Exhaust fumes are poisonous and can cause loss of consciousness and death within a short period of time.

Always operate the motorcycle in the open air or in an area with adequate ventilation.

Caution

The low oil pressure warning light should go out shortly after the engine starts.

If the low oil pressure warning light stays on after starting the engine, stop the engine immediately and investigate the cause.

Running the engine with low oil pressure will cause severe engine damage.

Moving Off

To move the motorcycle:

- Pull in the clutch lever and select first gear.
- Open the throttle a little and let out the clutch lever slowly.
- As the clutch starts to engage, open the throttle a little more, allowing enough engine speed to avoid stalling.

Note

A transponder is fitted within the key to turn off the engine immobiliser.

Only have one of the ignition keys near the ignition switch. Two ignition keys near the ignition switch may interrupt the signal between the transponder and the engine immobiliser.

In this situation the engine immobiliser will remain active until one of the ignition keys is removed.

How to Ride the Motorcycle

Changing Gears

Warning

Take care to avoid opening the throttle too far or too fast in any of the lower gears as this can lead to the front wheel lifting from the ground (pulling a 'wheelie') and to the rear tyre breaking traction (wheel spin).

Always open the throttle cautiously, particularly if you are unfamiliar with the motorcycle, as a 'wheelie' or loss of traction will cause loss of motorcycle control and an accident.

Warning

Do not change to a lower gear at speeds that will cause excessive engine rpm (r/min).

This can lock the rear wheel causing loss of control and an accident. Engine damage may also be caused.

Changing down should be done such that low engine speeds will be ensured.

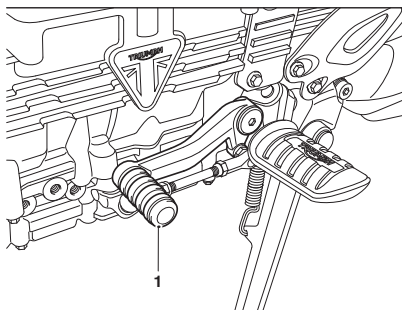

1. Gear change pedal

To change gears:

- Close the throttle while pulling in the clutch lever.
- Change into the next higher or lower gear.
- Open the throttle part way, while releasing the clutch lever. Always use the clutch when changing gear.

Note

The gear change mechanism is the positive stop type. This means that, for each movement of the gear change pedal, you can only select each gear, one after the other, in ascending or descending order.

Triumph Shift Assist (TSA) (if fitted)

Caution

Triumph Shift Assist (TSA) is optimised for on road use only.

It must not be used during off road or track riding.

Triumph Shift Assist (TSA) adjusts the engine torque to allow gears to engage, without closure of the throttle twist grip or operation of the clutch.

This feature works for both up shifts and down shifts of gear.

The clutch must be used for stopping and pulling away.

TSA will not operate if:

- The clutch is applied.
- An up shift is attempted by mistake when in 6th gear.
- A down shift is attempted by mistake when in 1st gear.

- An up shift is attempted at very low engine speeds.
- A down shift is attempted at very high engine speeds.
- The vehicle speed limiter is active.
- Cruise control is active.

TSA will be disabled when riding, if a TSA system malfunction is present.

Use a positive pedal force and release your foot from the gear lever between gear changes to make sure there is a smooth gear change.

For more information on enabling and disabling the TSA functionality, see page 47.

Braking

All motorcycle models are equipped with a partially integrated braking system, combined with the Anti-lock Braking System (ABS). This increases the braking efficiency when riding the motorcycle.

When the front brake is applied, a small amount of rear brake is also applied, allowing for balanced braking. The amount of rear brake application is related to the level of braking force applied by the rider through the front brake lever. Use of the rear brake pedal alone will only apply the rear brake.

How to Ride the Motorcycle

For full brake effectiveness, always operate the front brake lever and rear brake pedal together.

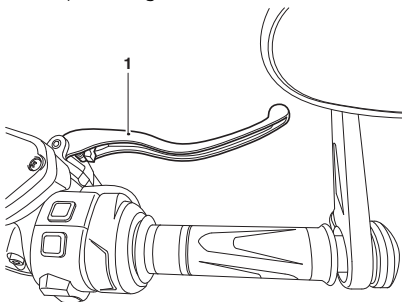

1. Front brake lever

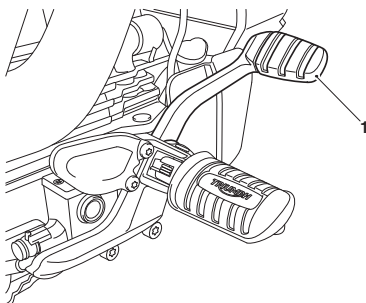

1. Rear brake pedal

Warning

WHEN BRAKING, OBSERVE THE FOLLOWING:

- Close the throttle completely, leaving the clutch engaged to allow the engine to help slow down the motorcycle.
- Change down one gear at a time such that the transmission is in first gear when the motorcycle comes to a complete stop.
- When stopping, always apply both brakes at the same time. Normally the front brake should be applied a little more than the rear.
- Change down or fully disengage the clutch as necessary to keep the engine from stalling.
- Never lock the brakes, as this may cause loss of control of the motorcycle and an accident.

Warning

For emergency braking, disregard down changing, and concentrate on applying the front and rear brakes as hard as possible without skidding. Riders should practice emergency braking in a traffic-free area.

Triumph strongly recommends that all riders take a course of instruction, which includes advice on safe brake operation. Incorrect brake technique could result in loss of control and an accident.

How to Ride the Motorcycle

Warning

For your safety, always exercise extreme caution when braking, accelerating or turning as any incautious action can cause loss of control and an accident. Independent use of the front or rear brakes reduces overall braking performance. Extreme braking may cause either wheel to lock, reducing control of the motorcycle and causing an accident (see ABS warnings below).

When possible, reduce speed or brake before entering a turn as closing the throttle or braking in mid-turn may cause wheel slip leading to loss of control and an accident.

When riding in wet or rainy conditions, or on loose surfaces, the ability to manoeuvre and stop will be reduced. All of your actions should be smooth under these conditions. Sudden acceleration, braking or turning may cause loss of control and an accident.

Warning

When descending a long, steep gradient or mountain pass, make use of the engine's braking effect by down changing and use both front and rear brakes intermittently.

Continuous brake application or use of the rear brake only can overheat the brakes and reduce their effectiveness leading to loss of motorcycle control and an accident.

Warning

Riding with your foot on the brake pedal or your hands on the brake lever may actuate the brake light, giving a false indication to other road users.

It may also overheat the brake, reducing braking effectiveness leading to loss of motorcycle control and an accident.

Warning

Do not coast with the engine switched off, and do not tow the motorcycle.

The transmission is pressure lubricated only when the engine is running.

Inadequate lubrication may cause damage or seizure of the transmission, which can lead to sudden loss of motorcycle control and an accident.

Warning

When using the motorcycle on loose, wet, or muddy roads, braking effectiveness will be reduced by dust, mud or moisture collecting on the brakes.

Always brake earlier in these conditions to make sure that brake surfaces are cleaned by the braking action.

Riding the motorcycle with brakes contaminated with dust, mud or moisture may cause loss of motorcycle control and an accident.

How to Ride the Motorcycle

Caution

Due to the nature of the partially integrated braking system, any attempts to spin the rear wheel whilst the front brake is applied (Burnout) will cause damage to the braking system and drivetrain.

Anti-lock Braking System (ABS)

Warning

ABS prevents the wheels from locking, therefore maximising the effectiveness of the braking system in emergencies and when riding on slippery surfaces. The potentially shorter braking distances ABS allows under certain conditions are not a substitute for good riding practice.

Always ride within the legal speed limit.

Never ride without due care and attention and always reduce speed in consideration of weather, road and traffic conditions.

Take care when cornering. If the brakes are applied in a corner, ABS will not be able to counteract the weight and momentum of the motorcycle. This can result in loss of control and an accident.

Under some circumstances it is possible that a motorcycle equipped with ABS may require a longer stopping distance.

Warning

If the ABS is not functioning, the brake system will continue to function as a non-ABS equipped brake system.

Do not continue to ride for longer than is necessary with the warning light illuminated.

Contact an authorised Triumph dealer as soon as possible to have the fault checked and rectified. In this situation braking too hard will cause the wheels to lock resulting in loss of motorcycle control and an accident.

Warning

After riding off-road with ABS disabled, always make sure that the ABS is enabled when returning to ride on public roads.

Riding on public roads with the ABS disabled will, if braking too hard, cause the wheels to lock resulting in loss of motorcycle control and an accident.

Note

The ABS operation may feel like a harder pedal pressure or a pulsation of the brake lever and pedal.

The ABS is not an integrated braking system and does not control both the front and rear brake at the same time so this pulsation may be felt in the lever, the pedal or both.

The ABS may be activated by sudden upward or downward changes in the road surface.

Optimised Cornering ABS

The optimised cornering Anti-lock Braking System (ABS) is a system that provides increased control if the ABS is activated when leaning in a corner whilst riding the motorcycle.

A sensor constantly monitors the lean angle of the motorcycle. If the motorcycle is leaning in a corner and the ABS is activated, the system will use the lean angle measurement to apply the ABS in a suitable method to assist the rider to maintain motorcycle control.

Warning

The optimised cornering ABS is a system designed to assist the rider in emergency braking situations.

The system is designed to give the rider increased control should the ABS be activated whilst the motorcycle is leaning in a corner.

The potential increased control that the optimised cornering braking system allows under certain conditions is not a substitute for good riding practice.

How to Ride the Motorcycle

Warning

Always ride within the legal speed limit. Never ride without due care and attention and always reduce speed in consideration of weather, surface and traffic conditions.

Take care when cornering.

If the motorcycle is leaning in a corner and the ABS is activated, the optimised cornering ABS will use the lean angle measurement from a sensor to apply the ABS in a suitable method to assist the rider to maintain motorcycle control. The optimised cornering ABS will not however be able to fully counteract the weight and momentum of the motorcycle and braking too hard whilst cornering may result in loss of motorcycle control and an accident.

Under some circumstances it is possible that a motorcycle equipped with optimised cornering ABS may require a longer stopping distance than an equivalent motorcycle without ABS, or an equivalent motorcycle equipped with ABS but not equipped with optimised cornering ABS.

Warning

If the optimised cornering ABS is not functioning, the ABS warning light will illuminate and a warning message is shown in the display.

In this situation, the ABS will continue to operate but without the optimised cornering function, provided that:

- There are no other ABS faults
- The ABS has not been disabled by the rider.

Do not continue to ride for longer than is necessary with the warning light illuminated. In the event of a fault, contact an authorised Triumph dealer as soon as possible to have the fault checked and rectified.

In this situation, braking too hard during cornering may result in loss of motorcycle control and an accident.

ABS Warning Light



When the ignition switch is turned to the ON position, it is normal for the ABS warning light to flash on and off.

If the ABS warning light is constantly illuminated it indicates that the ABS function is not available because the ABS has a malfunction that requires investigation.

If the ABS warning light becomes illuminated while riding, it indicates that the ABS has a malfunction that requires investigation. A warning message may be shown in the display.

Warning

The ABS warning light will illuminate after three minutes, if the rear wheel is driven while the motorcycle is on a stand.

If the motorcycle was ridden prior to being placed on a stand, this time will be reduced to one minute and the ABS warning light will be accompanied by the MIL.

This reaction is normal.

When the ignition is switched off and the motorcycle is restarted, the warning light(s) will remain illuminated until the motorcycle reaches a speed exceeding 6 mph (10 km/h).

Warning

The ABS system operates by comparing the relative speed of the front and rear wheels.

Use of non-recommended tyres can affect wheel speed and cause the ABS function not to operate, potentially leading to loss of control and an accident in conditions where the ABS would normally function.

Hill Hold Control

Hill hold control assists the rider in making hill starts. The system (when activated) will apply the rear brake to hold the motorcycle in position. The system will then automatically deactivate and release the rear brake when it detects that the rider is attempting to move off.

Warning

Avoid activating the hill hold control system on slippery surfaces.

The hill hold control system will not be able to prevent the motorcycle from slipping, if it is activated on a surface where there is insufficient levels of tyre grip to hold the motorcycle in position.

Activating the hill hold control system on a slippery surface could cause the motorcycle to slip, leading to loss of motorcycle control and an accident.

How to Ride the Motorcycle

Warning

The hill hold control system will deactivate if the side stand is moved to the down position, the ignition is switched off, the engine stop switch is moved to the STOP position or if the engine is stopped for any other reason.

The hill hold control system will also deactivate if a fault occurs which causes the Malfunction Indicator Light (MIL) to illuminate.

In these circumstances, the front brake must be manually applied to prevent the motorcycle from rolling.

Failure to prevent the motorcycle from rolling may lead to loss of motorcycle control and an accident.

Caution

The hill hold control system is not designed to be used as a parking brake.

Do not continually activate the hill hold system for periods of longer than 10 minutes.

Continuous activation of the hill hold control system for periods of longer than 10 minutes may cause damage to the ABS system.

Activation

The following conditions must be met before hill hold control can be activated:

- The engine must be running
- The side stand must be in the up position

- The motorcycle must be stationary.

When all of the above conditions are met, complete the following:

- Squeeze the front brake lever firmly and quickly, then release.
- Upon releasing the lever, a message is shown in the display and the hill hold warning light is shown in green. The hill hold control system is now active and the rear brake will be automatically applied.
- The message will remain shown in the display and the hill hold warning light will remain green until hill hold control is deactivated.
- The rear brake will remain applied until the system detects that the rider is attempting to move off, or hill hold control is manually deactivated by the rider.

Note

The hill hold control system will not operate if there is a fault with the ABS or engine management systems and the ABS and/or MIL warning lights are illuminated.

Deactivation

The hill hold control system will automatically deactivate when it detects that the rider is attempting to move off. The system will progressively release the rear brake to assist the rider in moving off.

The hill hold control system can also be manually deactivated by a second firm squeeze of the front brake lever. A message is shown briefly in the display and the hill hold warning light is then shown in amber.

Hill Hold Unavailable

If when attempting to activate the hill hold control system, the amber hill hold unavailable warning light is shown, this indicates one or more of the following:

- The activation conditions described on page 104 have not been met.
- There is a fault with the ABS or engine management systems and the ABS and/or MIL warning lights are illuminated. For more information, see the Warning Lights section on page 25.

A hill hold unavailable warning message is also shown in the display.

The hill hold control system can be enabled or disabled (see page 47).

Parking

Warning

Petrol is extremely flammable and can be explosive under certain conditions.

If parking inside a garage or other structure, be sure it is well ventilated and the motorcycle is not close to any source of flame or sparks. This includes any appliance with a pilot light.

Failure to follow the above advice may cause a fire resulting in damage to property or personal injury.

Warning

The engine and exhaust system will be hot after riding.

DO NOT park where pedestrians and children are likely to touch the motorcycle.

Touching any part of the engine or exhaust system when hot may cause unprotected skin to become burnt.

How to Ride the Motorcycle

Warning

Do not park on a soft or steeply inclined surface.

Parking under these conditions may cause the motorcycle to fall over causing damage to property and personal injury.

- Do not park on a lateral (sideways) incline of greater than 6° and never park facing downhill.

Note

When parking near traffic at night, or when parking in a location where parking lights are required by law, leave the tail, licence plate and position lights on.

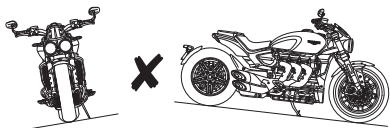
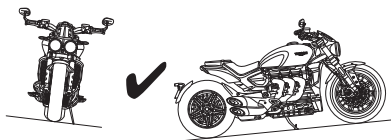

To park the motorcycle:

- Select neutral and turn the ignition switch to the OFF position.
- Lock the steering to help prevent theft.
- Always park on a firm, level surface to prevent the motorcycle from falling. This is particularly important when parking off-road.
- When parking on a hill, always park facing uphill to prevent the motorcycle from rolling off the stand. Engage first gear to prevent the motorcycle from moving.
- On a lateral (sideways) incline, always park such that the incline naturally pushes the motorcycle towards the side stand.

Considerations for High Speed Operation

Warning

This Triumph motorcycle should be operated within the legal speed limits for the particular road travelled.

Operating a motorcycle at high speeds can be potentially dangerous since the time available to react to given traffic situations is greatly reduced as road speed increases.

Always reduce speed in potentially hazardous driving conditions such as bad weather or heavy traffic.

Warning

Only operate this Triumph motorcycle at high speed in closed-course on-road competition or on closed-course racetracks.

High speed operation should only then be attempted by riders who have been instructed in the techniques necessary for high speed riding and are familiar with the motorcycle's characteristics in all conditions.

High speed operation in any other circumstances is dangerous and will lead to loss of motorcycle control and an accident.

Warning

The handling characteristics of a motorcycle at high speed may vary from those you are familiar with at legal road speeds.

Do not attempt high speed operation unless you have received sufficient training and have the required skills as a serious accident may result from incorrect operation.

Warning

The items listed below are extremely important and must never be neglected. A problem, which may not be noticed at normal operating speeds, may be greatly exaggerated at high speeds.

General

Make sure that the motorcycle has been maintained according to the scheduled maintenance chart.

Steering

Check that the handlebar turns smoothly without excessive free play or tight spots. Make sure that the control cables do not restrict the steering in any way.

Luggage

Make sure that any luggage containers are closed, locked and securely fitted to the motorcycle.

Brakes

Check that the front and rear brakes are functioning properly.

How to Ride the Motorcycle

Tyres

High speed operation is hard on tyres, and tyres that are in good condition are crucial to riding safely. Examine their overall condition, inflate to the correct pressure (when the tyres are cold), and check the wheel balance. Securely fit the valve caps after checking tyre pressures. Observe the information given in the Maintenance and Specification sections on tyre checking and tyre safety.

Fuel

Have sufficient fuel for the increased fuel consumption that will result from high speed operation.



Caution

In many countries, the exhaust system for this model is fitted with a catalytic converter to help reduce exhaust emission levels.

The catalytic converter can be permanently damaged if the motorcycle is allowed to run out of fuel or if the fuel level is allowed to get very low.

Always make sure you have adequate fuel for your journey.

Engine Oil

Make sure that the engine oil level is correct. Make sure that the correct grade and type of oil is used when topping up.

Final Drive Oil

Make sure that the final drive oil level is correct. Make sure that the correct grade and type of oil is used when topping up.

Coolant

Check that the coolant level is between the minimum and maximum levels in the expansion tank. Always check the level with the engine cold.

Electrical Equipment

Make sure that the headlight, rear/brake light, direction indicators, horn, etc. all work properly.

Miscellaneous

Visually check that all fixings are tight.

Accessories, Loading and Passengers

The addition of accessories and carriage of additional weight can affect the motorcycle's handling characteristics causing changes in stability and necessitating a reduction in speed. The following information has been prepared as a guide to the potential hazards of adding accessories to a motorcycle and carrying passengers and additional loads.

Accessories

Warning

Do not install accessories or carry luggage that impairs the control of the motorcycle.

Make sure that you have not adversely affected any lighting component, road clearance, banking capability (i.e. lean angle), control operation, wheel travel, front fork movement, visibility in any direction, or any other aspect of the motorcycle's operation.

Warning

Owners should be aware that the only approved parts, accessories and conversions for any Triumph motorcycle are those which carry official Triumph approval and are fitted to the motorcycle by an authorised dealer.

In particular, it is extremely hazardous to fit or replace parts or accessories whose fitting requires the dismantling of, or addition to, either the electrical or fuel systems and any such modification could cause a safety hazard.

The fitting of any non-approved parts, accessories or conversions may adversely affect the handling, stability or other aspect of the motorcycle operation that may result in an accident causing injury or death.

Triumph does not accept any liability whatsoever for defects caused by the fitting of non-approved parts, accessories or conversions or the fitting of any approved parts, accessories or conversions by non-approved personnel.

Accessories, Loading and Passengers

Warning

Never ride an accessory equipped motorcycle, or a motorcycle carrying a payload of any kind, at speeds above 80 mph (130 km/h). In either/both of these conditions, speeds in excess of 80 mph (130 km/h) should not be attempted even where the legal speed limit permits this.

The presence of accessories and/or payload will cause changes in the stability and handling of the motorcycle.

Failure to allow for changes in motorcycle stability may lead to loss of motorcycle control and an accident. When riding at high speed, always be aware that various motorcycle configuration and environmental factors can adversely affect the stability of your motorcycle. For example:

- Incorrectly balanced loads on both sides of the motorcycle
- Incorrectly adjusted front and rear suspension settings
- Incorrectly adjusted tyre pressures
- Excessively or unevenly worn tyres
- Side winds and turbulence from other vehicles
- Loose clothing.

Remember that the 80 mph (130 km/h) absolute limit will be reduced by the fitting of non-approved accessories, incorrect loading, worn tyres, overall motorcycle condition and poor road or weather conditions.

Loading

Warning

Incorrect loading may result in an unsafe riding condition leading to an accident.

Always make sure that any loads carried are evenly distributed on both sides of the motorcycle. Make sure that the load is correctly secured so that it will not move around while the motorcycle is in motion.

Evenly distribute the load within each pannier (if fitted). Pack heavy items at the bottom and on the inboard side of the pannier.

Always check the load security regularly (though not while the motorcycle is in motion) and make sure that the load does not extend beyond the rear of the motorcycle.

Never exceed the maximum vehicle loading weight as specified in the Specifications section.

This maximum loading weight is made up from the combined weight of the rider, passenger, any accessories fitted and any load carried.

For models that have adjustable suspension settings, make sure that front and rear spring preload and damping settings are suitable for the loading condition of the motorcycle. Note the maximum permissible payload for the panniers is stated on a label inside the pannier.

Accessories, Loading and Passengers

Warning

Never attempt to store any items between the frame and the fuel tank.

This can restrict the steering and will cause loss of control leading to an accident.

Weight attached to the handlebar or front fork will increase the mass of the steering assembly and can result in loss of steering control leading to an accident.

Warning

The maximum safe load for each pannier is stated on a label inside the pannier.

Never exceed this loading limit as this may cause the motorcycle to become unstable leading to loss of motorcycle control and an accident.

Warning

If the passenger seat is used to carry small objects, they must not exceed 5 kg (11 lbs) in weight, must not impair control of the motorcycle, must be securely attached and must not extend beyond the rear or sides of the motorcycle.

Carrying objects in excess of 5 kg (11 lbs) in weight, that are insecure, impair control or extend beyond the rear or sides of the motorcycle may lead to loss of motorcycle control and an accident.

Even if small objects are correctly loaded onto the passenger seat, the maximum speed of the motorcycle must be reduced to 80 mph (130 km/h).

Note

Adjust the headlight aim to compensate for additional loads (page 151).

Accessories, Loading and Passengers

Passengers

Warning

The handling and braking capabilities of a motorcycle will be affected by the presence of a passenger.

The rider must make allowances for these changes when operating the motorcycle with a passenger and should not attempt such operation unless trained to do so and without becoming familiar and comfortable with the changes in motorcycle operating characteristics that this brings about.

Motorcycle operation without making allowances for the presence of a passenger could lead to loss of motorcycle control and an accident.

Warning

Do not carry a passenger unless he or she is tall enough to reach the footrests provided.

A passenger who is not tall enough to reach the footrests will be unable to sit securely on the motorcycle and may cause instability leading to loss of control and an accident.

Warning

Your passenger should be instructed that he or she can cause loss of motorcycle control by making sudden movements or by adopting an incorrect seated position.

The rider should instruct the passenger as follows:

- It is important that the passenger sits still while the motorcycle is in motion and does not interfere with the operation of the motorcycle.
- To keep his or her feet on the passenger footrests and to firmly hold onto the seat strap or the rider's waist or hips.
- Advise the passenger to lean with the rider when travelling around corners and not to lean unless the rider does so.

Warning

Do not carry animals on your motorcycle.

An animal could make sudden and unpredictable movements that could lead to loss of motorcycle control and an accident.

Maintenance

Table of Contents

Scheduled Maintenance	115
Scheduled Maintenance Table	117
Engine Oil	119
Engine Oil Level Inspection	119
Engine Oil and Oil Filter Change	121
Disposal of Used Engine Oil and Oil Filters	123
Engine Oil Specification and Grade	123
Cooling System	124
Coolant Level Inspection	124
Coolant Level Adjustment	125
Coolant Change	126
Throttle Control	127
Clutch	127
Clutch Fluid Level Inspection and Adjustment	127
Clutch Inspection	128
Final Drive Unit	128
Final Drive Unit Oil Level Adjustment	128
Brakes	129
Brake Wear Inspection	129
Breaking-in New Brake Discs and Pads	130
Brake Pad Wear Compensation	130
Disc Brake Fluid	131
Front Brake Fluid Level Inspection and Adjustment	132
Rear Brake Fluid Inspection and Adjustment	132
Brake Light	133
Steering	134
Steering Inspection	134
Wheel Bearings Inspection	135
Front Fork Inspection	135
Front Suspension	136
Front Suspension Settings	136
Front Suspension Compression Damping Adjustment	136
Front Suspension Rebound Damping Adjustment	137

Maintenance

Rear Suspension	137
Rear Suspension Settings	137
Rear Suspension Spring Preload Adjustment	138
Rear Suspension Rebound Damping Adjustment	138
Rear Suspension Compression Damping Adjustment	139
Tyres	140
Tyre Inflation Pressures	141
Tyre Pressure Monitoring System (TPMS) (if fitted)	141
Tyre Replacement	142
Tyre Wear	144
Minimum Recommended Tread Depth	144
Fuses	145
Fuse Identification	145
Battery	146
Battery Removal	147
Battery Disposal	147
Battery Maintenance	147
Battery Discharge	148
Battery Discharge During Storage and Infrequent Use of the Motorcycle	148
Battery Charging	148
Battery Installation	149
Headlights	150
Daytime Running Light (DRL) (if fitted)	151
Headlight Adjustment	151
Bulb Replacement	152
Headlights	152
Direction Indicator Lights	152
License Plate Light	152
Rear Light	152
Mirrors	153
Jacking Points	154

Scheduled Maintenance

Warning

Triumph Motorcycles cannot accept any responsibility for damage or injury resulting from incorrect maintenance or improper adjustment carried out by the owner.

Incorrect or neglected maintenance can lead to a dangerous riding condition.

Always have an authorised Triumph dealer carry out the scheduled maintenance of this motorcycle.

Warning

All maintenance is vitally important and must not be neglected. Incorrect maintenance or adjustment may cause one or more parts of the motorcycle to malfunction. A malfunctioning motorcycle may lead to loss of control and an accident.

Weather, terrain and geographical location affect maintenance. The maintenance schedule should be adjusted to match the particular environment in which the motorcycle is used and the demands of the individual owner.

Special tools, knowledge and training are required in order to correctly carry out the maintenance items listed in the scheduled maintenance chart. Only an authorised Triumph dealer will have this knowledge and equipment.

Incorrect or neglected maintenance can lead to a dangerous riding condition. Always have an authorised Triumph dealer carry out the scheduled maintenance of this motorcycle.

To maintain the motorcycle in a safe and reliable condition, the maintenance and adjustments outlined in this section must be carried out as specified in the schedule of daily checks, and also in line with the scheduled maintenance chart. The information that follows describes the procedures to follow when carrying out the daily checks and some simple maintenance and adjustment items.

Maintenance

Scheduled maintenance may be carried out by your authorised Triumph dealer in three ways; annual maintenance, mileage based maintenance or a combination of both, depending on the mileage the motorcycle travels each year.

1. Motorcycles travelling less than 10,000 miles (16,000 km) per year must be maintained annually. In addition to this, mileage based items require maintenance at their specified intervals, as the motorcycle reaches this mileage.
2. Motorcycles travelling approximately 10,000 miles (16,000 km) per year must have the annual maintenance and the specified mileage based items carried out together.
3. Motorcycles travelling more than 10,000 miles (16,000 km) per year must have the mileage based items maintained as the motorcycle reaches the specified mileage. In addition to this, annual based items will require maintenance at their specified annual intervals.

In all cases maintenance must be carried out at or before the specified maintenance intervals shown. Consult an authorised Triumph dealer for advice on which maintenance schedule is most suitable for your motorcycle.

Triumph Motorcycles cannot accept any responsibility for damage or injury resulting from incorrect maintenance or improper adjustment.

Service Symbol/General Warning Symbol

 The service symbol will illuminate for five seconds after the motorcycle start up sequence as a reminder that a service is due in approximately 60 miles (100 km). The service symbol will illuminate permanently when the mileage is reached, it will remain permanently illuminated until the service interval is reset using the Triumph Diagnostic tool.

 The general warning symbol will flash if an ABS or engine management fault has occurred and the ABS and/or MIL warning lights are illuminated. Contact an authorised Triumph dealer as soon as possible to have the fault checked and rectified.

Scheduled Maintenance Table

Operation Description	Odometer Reading in Miles (km) or Time Period, whichever comes first					
		First Service	Annual Service	Mileage Based Service		
	Every	600 (1,000) 6 Months	Year	10,000 (16,000) 30,000 (48,000)	20,000 (32,000)	40,000 (64,000)
Lubrication						
Engine - check for leaks	Day	*	*	*	*	*
Engine oil - renew	-	*	*	*	*	*
Engine oil filter - renew	-	*	*	*	*	*
Fuel System and Engine Management						
Autoscan - carry out a full Autoscan using the Triumph diagnostic tool (print a customer copy)	-	*	*	*	*	*
Fuel system - check fuel hoses for chafing, cracks or damage. Replace if necessary	Day	*	*	*	*	*
Air filter - renew (replace more often if consistently riding in wet or dusty conditions)	-			*	*	*
Fuel filter - renew	-			*	*	*
Throttle bodies - balance	-			*	*	*
Ignition System						
Spark plugs - renew	-				*	*
Cooling System						
Cooling system - check for leaks	Day	*	*	*	*	*
Coolant level - check/adjust	Day	*	*	*	*	*
Cooling system - check coolant hoses for chafing, cracks or damage. Replace if necessary	-			*	*	*
Coolant - renew	Every 3 years, regardless of mileage					
Engine						
Clutch - check operation	Day	*	*	*	*	*
Clutch fluid levels - check	Day	*	*	*	*	*
Clutch fluid - renew	Every 2 years, regardless of mileage					
Valve clearances - check/adjust	-				*	*
Camshaft timing - check/adjust	-				*	*
Wheels and Tyres						
Wheel bearings - check for wear/smooth operation	Every 30,000 miles					
Rear wheel needle roller bearing (left hand side outer only) - lubricate	-			*	*	*
Tyre wear/tyre damage - check	Day	*	*	*	*	*
Tyre pressures - check/adjust	Day	*	*	*	*	*
Steering and Suspension						
Steering - check for free operation	Day	*	*	*	*	*
Front and rear suspension - check for damage/leaks/smooth operation	Day	*	*	*	*	*
Fork oil - renew	Every 30,000 miles					
Headstock bearings - check	-		*			
Headstock bearings - lubricate	Every 30,000 miles					
Swinging arm spindle - lubricate	Every 30,000 miles					
Rear suspension linkage - lubricate	Every 30,000 miles					

Maintenance

Operation Description	Odometer Reading in Miles (km) or Time Period, whichever comes first					
		First Service	Annual Service	Mileage Based Service		
	Every	600 (1,000) 6 Months	Year	10,000 (16,000) 30,000 (48,000)	20,000 (32,000)	40,000 (64,000)
Brakes						
Brake system - check operation	Day	*	*	*	*	*
Brake pads - check wear levels	Day	*	*	*	*	*
Brake fluid levels - check	Day	*	*	*	*	*
Brake fluid - renew	Every 2 years, regardless of mileage					
Final Drive						
Final drive - check for oil leaks	Day	*	*	*	*	*
Final drive oil level - check	-	*	*	*	*	*
Final drive oil - renew	-	*	*	*	*	*
Electrical						
Lights, instruments and electrical systems - check	Day	*	*	*	*	*
General						
Instruments, chassis ECM and engine ECM - check for latest calibration download using the Triumph diagnostic tool	-	*	*	*	*	*
Bank angle indicators - check for wear	Day	*	*	*	*	*
Side stand - check for smooth operation	Day			*	*	*
Side stand pivot pin - clean	-			*	*	*
Backrest (if fitted) - check for smooth operation	Day			*		
Accessory Pannier Rails - check for smooth operation	Day			*		
Carry out all outstanding Service Bulletin and warranty work	-	*	*	*	*	*
Carry out road test	-	*	*	*	*	*
Complete the service record book and reset the service indicator	-	*	*	*	*	*

Engine Oil



Warning

Motorcycle operation with insufficient, deteriorated, or contaminated engine oil will cause accelerated engine wear and may result in engine or transmission seizure.

Seizure of the engine or transmission may lead to sudden loss of motorcycle control and an accident.

In order for the engine, transmission, and clutch to function correctly, maintain the engine oil at the correct level, and change the oil and oil filter in accordance with scheduled maintenance requirements.

Engine Oil Level Inspection

Warning

Never start the engine or run the engine in a confined area.

Exhaust fumes are poisonous and can cause loss of consciousness and death within a short period of time.

Always operate the motorcycle in the open air or in an area with adequate ventilation.

Warning

If the engine has recently been running, the exhaust system will be hot.

Before working on or near the exhaust system, allow sufficient time for the exhaust system to cool as touching any part of a hot exhaust system could cause burn injuries.

Caution

Never check or adjust the engine oil when the engine is hot.

Any attempt to check or adjust the engine oil when the engine is hot may result in insufficient engine oil causing engine damage.

Always check or adjust the engine oil when the engine is cold.

Caution

Running the engine with insufficient engine oil will cause engine damage.

If the low oil pressure indicator remains on, stop the engine immediately and investigate the situation.

Maintenance

Note

An accurate indication of the level of oil in the engine is only shown when the engine is cold and the motorcycle is on the side stand.

This method of checking the engine oil is especially important to make sure the oil volume is distributed correctly because this model has a dry sump engine. Failure to follow this method will result in an inaccurate indication of oil in the engine.

To inspect the engine oil level:

- Make sure the engine is cold.
- Start the engine and run at idle for 60 - 90 seconds.

Note

Do not operate the throttle while the engine is at idle. This will give an inaccurate oil level on the engine oil dipstick.

- Stop the engine, then wait for at least three minutes to allow the oil to settle.
- Turn the oil filler cap anticlockwise and remove it.

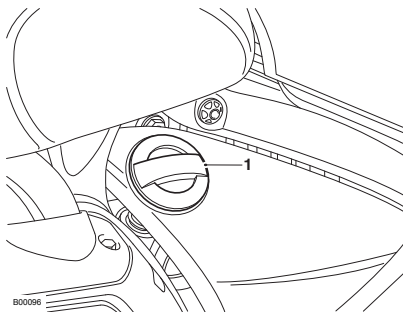

1. Oil filler cap

- Remove the oil dipstick from the oil filler tube, wipe the dipstick clean and refit into the oil filler tube, making sure to push the engine oil dipstick fully in.
- Remove the engine oil dipstick.
- The engine contains a sufficient amount of oil if the oil level is between the minimum and maximum marks on the engine oil dipstick.

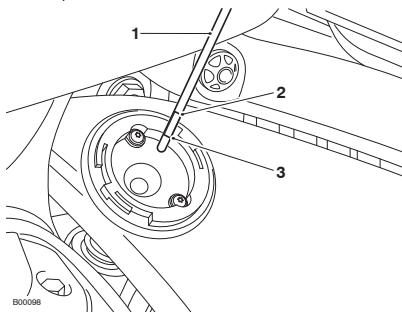

1. Engine oil dipstick
2. Maximum limit
3. Minimum limit

- If the level is near or below the minimum mark, add the recommended engine oil, a little at a time, up to the maximum mark on the engine oil dipstick.

Note

Make sure no foreign matter or contamination enters the engine during an engine oil change or top up. Contamination entering the engine may lead to engine damage.

- Once the correct level is reached, fit the engine oil dipstick and the oil filler cap.

Engine Oil and Oil Filter Change

Warning

Prolonged or repeated contact with engine oil can lead to skin dryness, irritation and dermatitis.

Used engine oil contains harmful contamination that can lead to skin cancer.

Always wear suitable protective clothing and avoid skin contact with used oil.

Warning

The oil may be hot to the touch.

Avoid contact with the hot oil by wearing suitable protective clothing, gloves, eye protection, etc.

Contact with hot oil may cause the skin to be scalded or burned.

The engine oil and oil filter must be replaced in accordance with scheduled maintenance requirements.

To change the engine oil and oil filter:

- Warm up the engine thoroughly, and then stop the engine. Secure the motorcycle on the side stand on level ground.
- Place an oil drain pan beneath the engine.

- Remove the three sump plugs from the bottom of the sump and allow the engine oil to drain. Discard the washers.

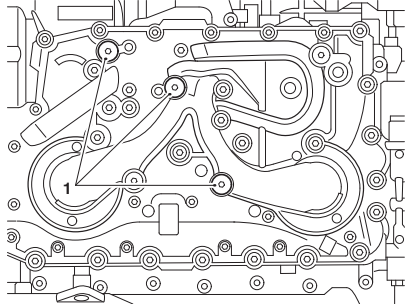

1. Engine oil drain plugs

- Release the fixings, move the radiator lower cowl forward to disengage the upper retaining clips and remove the lower cowl.

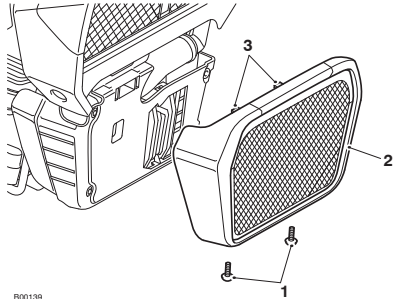

B00139

1. Fixings
2. Lower cowl
3. Retaining clips

- Position the oil drain pan beneath the engine oil filter.

Note

To access the oil filter, the radiator lower surround will need to be pivoted slightly forward.

Maintenance

- Release the two fixings securing the radiator lower surround to its bracket.
- Pivot the radiator lower surround. Unscrew and remove the engine oil filter using Triumph service tool T3880313. Dispose of the old filter in an environmentally friendly way.

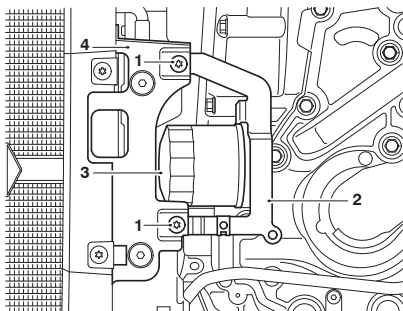

1. Fixings
2. Bracket
3. Oil filter
4. Radiator lower surround

- Prefill the replacement engine oil filter with the new engine oil.
- Apply a thin smear of clean engine oil to the sealing ring of the new engine oil filter.
- Fit the engine oil filter and tighten to 10 Nm.
- Secure the radiator lower surround to its bracket and tighten the fixings to 5 Nm.
- After the engine oil has completely drained out, fit a new sealing washer to the three sump plugs.
- Fit and tighten the sump plugs to 25 Nm.

Note

An accurate indication of the level of oil in the engine is only shown when the engine is cold and the motorcycle is on the side stand.

This method of checking the engine oil is especially important to make sure the oil volume is distributed correctly because this model has a dry sump engine. Failure to follow this method will result in an inaccurate indication of oil in the engine.

- Using a suitable funnel, fill the engine with 4.6 litres of new semi or fully synthetic 15W/50 motorcycle engine oil which meets specification API SH (or higher) and JSO MA, such as Castrol Power 1 4T.
- Fit the dipstick, start the engine and allow it to idle for a 60 to 90 seconds.

Note

Do not operate the throttle while the engine is at idle. This will give an inaccurate oil level on the engine oil dipstick.

- Make sure that the low oil pressure warning light remains off after starting and a warning message is not shown in the display screen.
- Stop the engine, then wait for at least three minutes to allow the oil to settle. Add the recommended engine oil, a little at a time, up to the maximum mark on the engine oil dipstick.

Caution

Raising the engine speed above idle before the oil reaches all parts of the engine can cause engine damage or seizure. Only raise engine speed after running the engine for 60 seconds to allow the oil to circulate fully.

Caution

If the engine oil pressure is too low, the low oil pressure warning light will illuminate. If this light stays on when the engine is running, stop the engine immediately and investigate the cause.

Running the engine with low oil pressure will cause engine damage.

Engine Oil Specification and Grade (15W/50)

This models high performance fuel injected engine is designed to use 15W/50 semi or fully synthetic motorcycle engine oil that meets specification API SH (or higher) and JASO MA, such as Castrol Power 1 4T

Do not add any chemical additives to the engine oil. The engine oil also lubricates the clutch and any additives could cause the clutch to slip.

Do not use mineral, vegetable, non-detergent oil, castor based oils or any oil not conforming to the required specification. The use of these oils may cause instant, severe engine damage.

Make sure that no foreign matter enters the crankcase during an engine oil change or top up.

Disposal of Used Engine Oil and Oil Filters

To protect the environment, do not pour oil on the ground, down sewers or drains, or into watercourses. Do not place used oil filters in with general waste. If in doubt, contact your local authority.

Maintenance

Cooling System



To ensure efficient engine cooling, check the coolant level each day before riding the motorcycle, and top up the coolant if the level is low.

Note

A year round, Hybrid Organic Acid Technology (known as Hybrid OAT or HOAT) coolant is installed in the cooling system when the motorcycle leaves the factory. It is coloured green, contains a 50% solution of ethylene glycol based antifreeze, and has a freezing point of -35°C (-31°F).

Corrosion Inhibitors

Warning

HD4X Hybrid OAT coolant contains corrosion inhibitors and antifreeze suitable for aluminium engines and radiators. Always use the coolant in accordance with the instructions of the manufacturer.

Coolant that contains anti-freeze and corrosion inhibitors contains toxic chemicals that are harmful to the human body. Never swallow antifreeze or any of the motorcycle coolant.

Note

HD4X Hybrid OAT coolant, as supplied by Triumph, is premixed and does not need to be diluted prior to filling or topping up the cooling system.

To protect the cooling system from corrosion, the use of corrosion inhibitor chemicals in the coolant is essential.

If coolant containing a corrosion inhibitor is not used, the cooling system will accumulate rust and scale in the water jacket and radiator. This will block the coolant passages, and considerably reduce the efficiency of the cooling system.

Coolant Level Inspection

The coolant expansion tank is located on the right hand side of the motorcycle, in the radiator lower cowl.

The coolant level within the coolant expansion tank can be inspected without removing any covers.

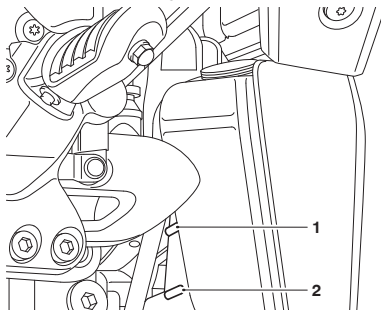

1. MAX mark
2. MIN mark

To inspect the coolant level:

- Allow the engine to cool. The coolant level should be checked when the engine is cold (at room or ambient temperature).
- Position the motorcycle on level ground and in an upright position.
- Check the coolant level in the coolant expansion tank. The coolant level must be between the MAX (upper line) and MIN (lower line) marks.
- If the coolant is below the MIN (minimum) level, the coolant level must be adjusted. For more information, see page 125.

Note

If the coolant level is being checked because the coolant has overheated, also check the level in the radiator and top up if necessary.

In an emergency, distilled water can be added to the cooling system. However, the coolant must then be drained and replenished with HD4X Hybrid OAT coolant as soon as possible.

Coolant Level Adjustment

Warning

Do not remove the expansion tank or radiator pressure cap when the engine is hot.

When the engine is hot, the coolant inside the radiator will be hot and also under pressure.

Contact with this hot, pressurised coolant will cause scalds and skin damage.

Caution

If hard water is used in the cooling system, it will cause scale accumulation in the engine and radiator and considerably reduce the efficiency of the cooling system.

Reduced cooling system efficiency may cause the engine to overheat and suffer severe damage.

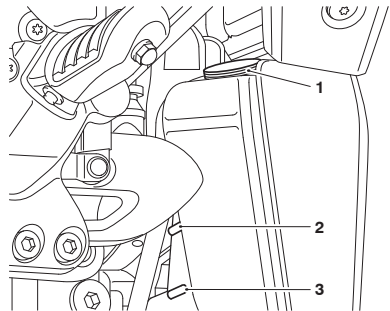

1. Coolant expansion tank cap
2. MAX mark
3. MIN mark

To adjust the coolant level:

- Allow the engine to cool. The coolant level should be adjusted when the engine is cold.
- Position the motorcycle on level ground and in an upright position.
- The coolant level must be between the MAX (upper line) and MIN (lower line) marks in the coolant expansion tank.
- Remove the coolant expansion tank cap from the coolant expansion tank.

Maintenance

- Add coolant mixture through the filler opening until the level reaches the MAX mark.
- Refit the coolant expansion tank cap.

Coolant Change

It is recommended that the coolant is changed by an authorised Triumph dealer in accordance with scheduled maintenance requirements.

Check the radiator hoses for cracks or deterioration, and tension clips for tightness in accordance with scheduled maintenance requirements. Have your authorised Triumph dealer replace any defective items.

Check the radiator grille and fins for obstructions by insects, leaves or mud. Clean off any obstructions with a stream of low pressure water.

Radiator and Hoses

Warning

The fan operates automatically when the engine is running.

Always keep hands and clothing away from the fan.

Contact with the rotating fan may cause an accident and/or personal injury.

Caution

Using high pressure water sprays, such as from a car wash facility or household pressure washer, can damage the radiator fins, cause leaks and impair the radiator's efficiency.

Do not obstruct or deflect airflow through the radiator by installing unauthorised accessories, either in front of the radiator or behind the cooling fan.

Interference with the radiator airflow can cause overheating, potentially resulting in engine damage.

Throttle Control

Warning

Always be alert for changes in the 'feel' of the throttle control and have the throttle system checked by an authorised Triumph dealer if any changes are detected.

Changes can be due to wear in the mechanism, which could lead to a sticking throttle control.

A sticking or stuck throttle control will lead to loss of motorcycle control and an accident.

Warning

Use of the motorcycle with a sticking or damaged throttle control will interfere with the throttle function resulting in loss of motorcycle control and an accident.

To avoid continued use of a sticking or damaged throttle control, always have it checked by your authorised Triumph dealer.

Throttle Inspection

To inspect the throttle:

- Check that the throttle opens smoothly, without undue force and that it closes without sticking.
- Have your authorised Triumph dealer check the throttle system if a problem is detected or any doubt exists.

Clutch

The motorcycle is equipped with a hydraulically operated clutch that does not require adjustment.

Clutch Fluid Level Inspection and Adjustment

Warning

If there has been an appreciable drop in the level of the fluid in the clutch fluid reservoir, consult your authorised Triumph dealer for advice before riding.

Riding with depleted clutch fluid levels, or with a clutch fluid leak is dangerous and could potentially lead to loss of motorcycle control and an accident.

The clutch fluid reservoir is located on the left hand side handlebar.

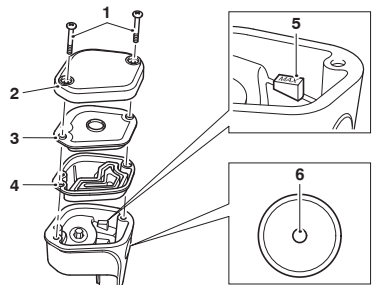

1. Reservoir cap screws
2. Reservoir cap
3. Plastic plate
4. Diaphragm seal
5. MAX (maximum) level line
6. MIN (minimum) level line

Maintenance

To inspect the clutch fluid level:

- Check the level of clutch fluid visible in the window at the side of the reservoir body.
- The clutch fluid level in the reservoir must be kept between the MAX (maximum) and MIN (minimum) level lines (reservoir held horizontal).

To adjust the clutch fluid level:

- Clean the reservoir cap before removing. This helps to prevent dirt and dust entering the reservoir.
- Remove the reservoir cap screws.
- Remove the reservoir cap, plastic plate and the diaphragm seal.
- Fill the reservoir to the MAX level line using new DOT 4 fluid from a sealed container.
- Refit the diaphragm seal noting that it is correctly positioned in the reservoir.
- Refit the plastic plate.
- Refit the reservoir cap.
- Refit and tighten the reservoir cap screws to 1.5 Nm.

Clutch Inspection

Check that there is 2 - 3 mm clutch lever free play at the lever.

If there is an incorrect amount of free play, adjustments must be made.

Final Drive Unit

Check the final drive unit for oil leaks in accordance with the scheduled maintenance chart.

Check the final drive unit for oil changes in accordance with the scheduled maintenance chart.

Final Drive Unit Oil Level Adjustment

Warning

Under no circumstances should the final drive unit be disassembled.

Failure to observe this warning could lead to a malfunction of the final drive unit causing lock-up of the rear wheel leading to loss of motorcycle control and an accident.

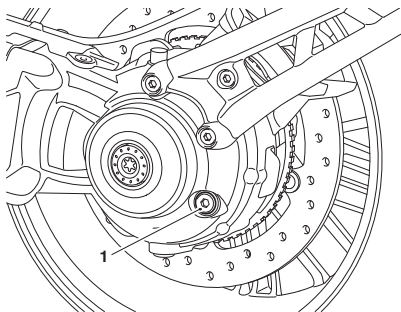

1. Filler level plug

To adjust the oil level in the final drive unit:

- Remove the filler level plug.

- Fill the final drive unit with fully synthetic 75W/90 hypoid oil that meets specification API Service Level GL5, such as Castrol SAF-XO fully synthetic hypoid oil, until the level of oil inside the final drive unit is level with the bottom of the filler.
- Refit the filler level plug and tighten to 25 Nm.

Brakes

Brake Wear Inspection

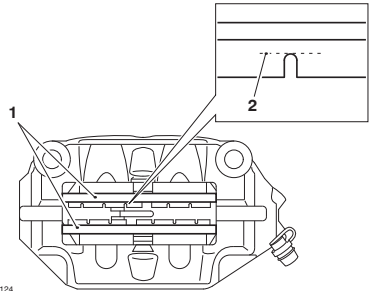

B00124

1. Brake pads
2. Minimum thickness line

Brake pads must be inspected in accordance with scheduled requirements and replaced if worn to, or beyond the minimum service thickness.

If the lining thickness of any pad (front or rear brakes) is less than 1.5 mm (0.06 in), that is, if the pad has worn down to the bottom of the grooves, replace all the pads on the wheel.

Maintenance

Breaking-in New Brake Discs and Pads

Warning

Brake pads must always be replaced as a wheel set. At the front, where two calipers are fitted on the same wheel, replace all the brake pads in both calipers.

Replacing individual pads will reduce braking efficiency and may cause an accident.

After replacement brake pads have been fitted, ride with extreme caution until the new pads have broken in.

Warning

Brake pad wear will be increased if the motorcycle is used frequently off-road. Always inspect the brake pads more frequently if the motorcycle is used off-road, and replace the brake pads before they become worn to, or beyond the minimum service thickness.

Riding with worn brake pads may reduce braking efficiency, leading to loss of motorcycle control and an accident.

Triumph recommend a period of careful breaking-in for new brake discs and pads that, if followed correctly, will optimise their performance and longevity.

The recommended distance for breaking-in new brake discs and pads is 200 miles (300 km).

During the breaking-in period, avoid extreme braking, ride with caution and allow for greater braking distances.

Brake Pad Wear Compensation

Warning

If the brake lever or pedal feels soft when it is applied, or if the lever/pedal travel becomes excessive, there may be air in the brake pipes and hoses or the brakes may be defective.

It is dangerous to operate the motorcycle under such conditions and your authorised Triumph dealer must rectify the fault before riding.

Riding with defective brakes may lead to loss of motorcycle control and an accident.

Disc and brake pad wear is automatically compensated for and has no effect on the brake lever or pedal action. There are no parts that require adjustment on the front and rear brakes.

Disc Brake Fluid

Warning

Brake fluid is hygroscopic which means it will absorb moisture from the air.

Any absorbed moisture will greatly reduce the boiling point of the brake fluid causing a reduction in braking efficiency.

Because of this, always replace brake fluid in accordance with scheduled maintenance requirements.

Always use new brake fluid from a sealed container and never use fluid from an unsealed container or from one which has been previously opened.

Do not mix different brands or grades of brake fluid.

Check for fluid leakage around brake fittings, seals and joints and also check the brake hoses for splits, deterioration and damage.

Always rectify any faults before riding.

Failure to observe and act upon any of these items may cause a dangerous riding condition leading to loss of control and an accident.

Warning

If the ABS is not functioning, the brake system will continue to function as a non-ABS equipped brake system.

In this situation, braking too hard will cause the wheels to lock resulting in loss of control and an accident.

Reduce speed and do not continue to ride for longer than is necessary with the indicator light illuminated. Contact an authorised Triumph dealer as soon as possible to have the fault checked and rectified.

Inspect the level of brake fluid in both reservoirs and change the brake fluid in accordance with scheduled maintenance requirements. Use only DOT 4 fluid as recommended in the Specification section. The brake fluid must also be changed if it becomes, or is suspected of having become contaminated with moisture or any other contaminants.

Note

A special tool is required to bleed the ABS braking system. Contact your authorised Triumph dealer when the brake fluid needs renewing or the hydraulic system requires maintenance.

Maintenance

Front Brake Fluid Level Inspection and Adjustment

Warning

If there has been an appreciable drop in the level of the fluid in either fluid reservoir, consult your authorised Triumph dealer for advice before riding.

Riding with depleted brake fluid levels, or with a brake fluid leak is dangerous and will cause reduced brake performance potentially leading to loss of motorcycle control and an accident.

The front brake fluid reservoir is located on the right hand side handlebar.

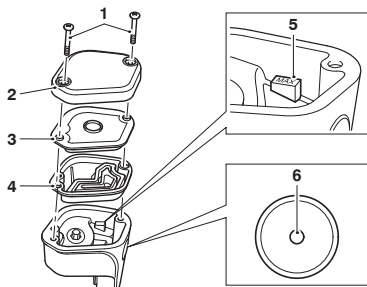

1. Reservoir cap screws
2. Reservoir cap
3. Plastic plate
4. Diaphragm seal
5. MAX (maximum) level
6. MIN (minimum) level

To inspect the front brake fluid level:

- Position the motorcycle on level ground, in an upright position.
- Check the level of brake fluid visible in the window at the side of the reservoir body.

- The brake fluid level in the reservoir must be kept above the MIN level line (reservoir held horizontal).

To adjust the front brake fluid level:

- Position the motorcycle on level ground, in an upright position.
- Clean the reservoir cap before removing. This helps to prevent dirt and dust entering the reservoir.
- Remove the reservoir cap screws.
- Remove the reservoir cap, plastic plate and the diaphragm seal.
- Fill the reservoir to the MAX level line using new DOT 4 fluid from a sealed container.
- Refit the diaphragm seal noting that is correctly positioned in the reservoir.
- Refit the plastic plate.
- Refit the reservoir cap.
- Refit and tighten the reservoir cap screws to 1.5 Nm.

Rear Brake Fluid Inspection and Adjustment

Warning

If there has been an appreciable drop in the level of the fluid in either fluid reservoir, consult your authorised Triumph dealer for advice before riding.

Riding with depleted brake fluid levels, or with a brake fluid leak is dangerous and will cause reduced brake performance potentially leading to loss of motorcycle control and an accident.

The rear brake reservoir is located near to the rider's foot rest, behind the heel guard on the right hand side of the motorcycle.

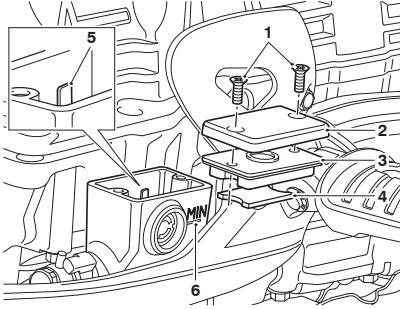

1. Reservoir cap screws
2. Reservoir cap
3. Diaphragm seal
4. Float
5. MAX (maximum) level line
6. MIN (minimum) level line

To inspect the rear brake fluid level:

- Position the motorcycle on level ground, in an upright position.
- Check the level of brake fluid visible in the window at the front of the reservoir body.
- The brake fluid level in the reservoir must be kept above the MIN level line (reservoir held horizontal).

To adjust the rear brake fluid level:

- Position the motorcycle on level ground, in an upright position.
- Clean the reservoir cap before removing. This helps to prevent dirt and dust entering the reservoir.
- Remove the reservoir cap screws and remove the reservoir cap.
- Remove the diaphragm seal and the float.

- Fill the reservoir between the MIN level line and the MAX level line using new DOT 4 brake fluid from a sealed container.
- Refit the float.
- Refit the diaphragm seal making sure that it is correctly positioned between the reservoir cap and reservoir body.
- Refit the reservoir cap.
- Refit the reservoir cap screws and tighten to 2 Nm.

Brake Light

Warning

Riding the motorcycle with defective brake lights is illegal and dangerous.

An accident causing injury to the rider and other road users may result from use of a motorcycle with defective brake lights.

The brake light is activated independently by either the front or rear brake. If, with the ignition ON, the brake light does not work when the front brake lever is pulled or the rear brake pedal is pressed, have your authorised Triumph dealer investigate and rectify the fault.

Maintenance

Steering

⚠ Caution

To prevent risk of injury from the motorcycle falling during the inspection, make sure that the motorcycle is stabilised and secured on a suitable support.

Do not exert extreme force against each wheel or rock each wheel vigorously as this may cause the motorcycle to become unstable and cause injury by falling from its support.

Make sure that the position of the support block will not cause damage to the motorcycle.

Steering Inspection

⚠ Warning

Riding the motorcycle with incorrectly adjusted or defective steering (headstock) bearings is dangerous and may cause loss of motorcycle control and an accident.

The steering (headstock) bearings must be lubricated and inspected in accordance with scheduled maintenance requirements. Always inspect the wheel bearings at the same time as the steering bearings.

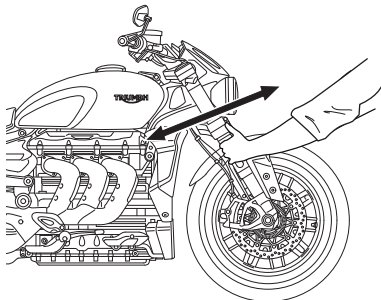

Inspecting the Steering for Free Play

To inspect the steering:

- Position the motorcycle on level ground, in an upright position.
- Raise the front wheel above the ground and support the motorcycle.
- Standing at the front of the motorcycle, hold the lower end of the front forks and try to move them forward and backward.
- If any free play can be detected in the steering (headstock) bearings, ask your authorised Triumph dealer to inspect and rectify any faults before riding.
- Remove the support and place the motorcycle on the side stand.

Wheel Bearings Inspection

Warning

Riding with worn or damaged front or rear wheel bearings is dangerous and may cause impaired handling and instability leading to an accident.

If in doubt, have the motorcycle inspected by an authorised Triumph dealer before riding.

Note

If the wheel bearings in the front or rear wheel allow play in the wheel hub, are noisy, or if the wheel does not turn smoothly, have your authorised Triumph dealer inspect the wheel bearings.

The wheel bearings must be inspected at the intervals specified in the scheduled maintenance chart.

Front Fork Inspection

Warning

Riding the motorcycle with defective or damaged suspension is dangerous and may lead to loss of control and an accident.

Warning

Never attempt to dismantle any part of the suspension units

All suspension units contain pressurised oil.

Skin and eye damage can result from contact with the pressurised oil.

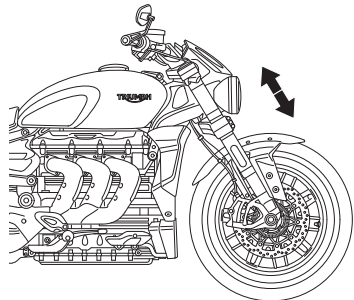

Inspecting the Front Forks

To inspect the forks:

- Position the motorcycle on level ground.
- While holding the handlebars and applying the front brake, pump the forks up and down several times.
- If roughness or excessive stiffness is detected, consult your authorised Triumph dealer.
- Examine each fork for any sign of damage, scratching of the slider surface, or for oil leaks.
- If any damage or leakage is found, consult an authorised Triumph dealer.

Maintenance

Front Suspension

Warning

Make sure that the correct balance between front and rear suspension is maintained.

Suspension imbalance could significantly change handling characteristics leading to loss of control and an accident.

Refer to the table for further information or consult your authorised Triumph dealer.

Front Suspension Settings

The motorcycle is delivered from the factory with all the suspension settings set at the Standard Solo Riding setting, as shown in the relevant suspension table.

The details shown in the tables are only a guide. Setting requirements may vary for rider and passenger weight and personal preferences.

Suspension Settings			
Loading Condition		Compression Damping ¹	Rebound Damping ¹
Solo Riding	Standard	2	2
	Comfort (Softer)	2	2
	Sport (Firmer)	1	0.5
Solo with Loaded Luggage		2	2
Rider and Passenger		2	2
Rider and Passenger with Loaded Luggage		2	2

¹ Number of clicks anticlockwise from the fully clockwise (maximum) position.

Front Suspension Compression Damping Adjustment

The compression damping adjuster is located at the top of the right hand fork.

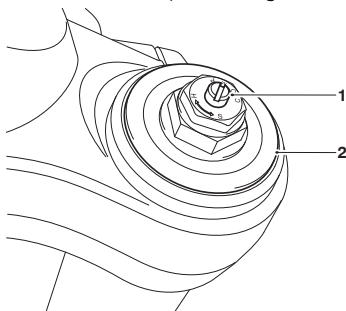

1. Compression damping adjuster
2. Fork top cap

To change the compression damping setting:

- Rotate the slotted compression damping adjuster clockwise to increase, or anticlockwise to decrease.
- Always count the number of anticlockwise turns from the fully clockwise position.

Front Suspension Rebound Damping Adjustment

The rebound damping adjuster is located at the top of the left hand fork.

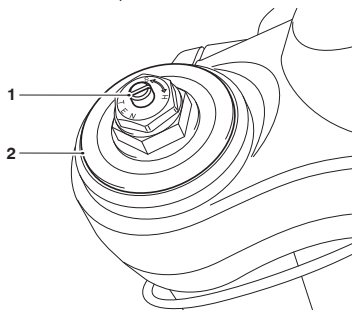

1. Rebound damping adjuster
2. Fork top cap

To change the rebound damping setting:

- Rotate the slotted rebound damping adjuster clockwise to increase, or anticlockwise to decrease.
- Always count the number of anticlockwise turns from the fully clockwise position.

Rear Suspension

Rear Suspension Settings

The details shown in the tables are only a guide. Setting requirements may vary for rider and passenger weight and personal preferences.

Preload Suspension Settings		
Loading Condition		Rear Spring Preload ¹
Solo Riding	Standard	Fully Anticlockwise (Minimum)
	Comfort (Softer)	Fully Anticlockwise (Minimum)
	Sport (Firmer)	Fully Anticlockwise (Minimum)
Solo with Loaded Luggage		9
Rider and Passenger		0 (Maximum)
Rider and Passenger with Loaded Luggage		0 (Maximum)

¹ Number of clicks anticlockwise from the fully clockwise (maximum) position.

Damping Suspension Settings			
Loading Condition		Rear Rebound Damping ¹	Rear Compression Damping ¹
Solo Riding	Standard	3	3
	Comfort (Softer)	Fully Anticlockwise	Fully Anticlockwise
	Sport (Firmer)	2	2
Solo with Loaded Luggage		2	2
Rider and Passenger		0.25	0
Rider and Passenger with Loaded Luggage		0.25	0

¹ Number of turns anticlockwise from the fully clockwise (closed) position noting that the first turn is counted as one.

Maintenance

Rear Suspension Spring Preload Adjustment

The spring preload adjuster is located next to the rear suspension unit.

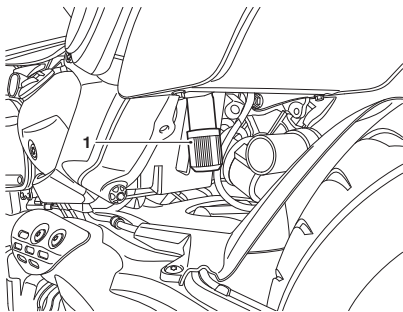

1. Spring preload adjuster

To change the spring preload setting:

- Look upwards from the bottom of the spring preload adjuster to the top of the spring preload adjuster, and rotate the adjuster clockwise to increase and anticlockwise to decrease.
- Always count the number of adjuster clicks/turns anticlockwise from the fully clockwise position.

Note

The motorcycle is delivered from the factory with the spring preload setting in the fully anticlockwise (minimum) position.

Rear Suspension Rebound Damping Adjustment

The rebound damping adjuster is located behind the side panel on the right hand side of the motorcycle.

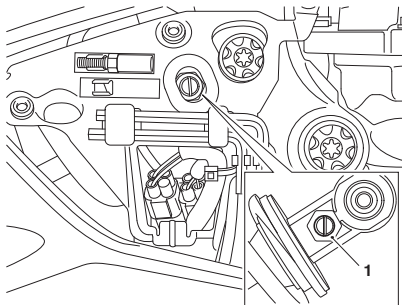

1. Rebound damping adjuster

To change the rebound damping setting:

- Remove the right hand side panel, see page 81.
- Insert a flat head screwdriver into the slotted rebound damping adjuster.
- Rotate the rebound damping adjuster clockwise to increase, or anticlockwise to decrease.
- Always count the number of anticlockwise turns from the fully clockwise position.

Rear Suspension Compression Damping Adjustment

The compression damping adjuster is located at the bottom of the rear suspension unit on the right hand side of the motorcycle.

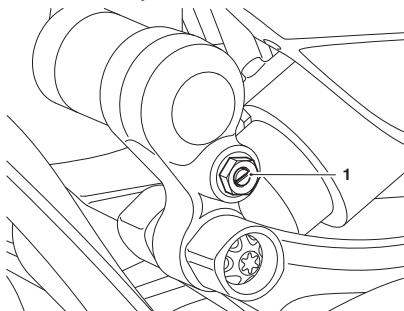

1. Compression damping adjuster

To change the compression damping setting:

- Insert a flat head screwdriver into the slotted compression damping adjuster.
- Rotate the compression damping adjuster clockwise to increase, or anticlockwise to decrease.
- Always count the number of anticlockwise turns from the fully clockwise position.

Bank Angle Indicators

Warning

Use of a motorcycle with bank angle indicators worn beyond the maximum limit will allow the motorcycle to be banked to an unsafe angle.

Banking to an unsafe angle may cause instability, loss of motorcycle control and an accident.

Bank angle indicators are located on the rider's footrests.

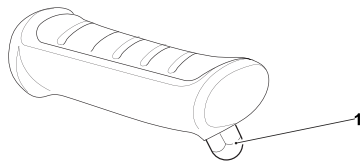

circ_1

1. Bank angle indicator

Regularly check the bank angle indicators for wear.

Bank angle indicators must be replaced when they have reached the maximum wear limit of 5 mm in length.

Maintenance

Tyres



cboa

This model is equipped with tubeless tyres, valves and wheel rims. Use only tyres marked TUBELESS and tubeless valves on rims marked SUITABLE FOR TUBELESS TYRES.

Warning

Do not install tube-type tyres on tubeless rims. The bead will not seat and the tyres could slip on the rims, causing rapid tyre deflation that may result in a loss of motorcycle control and an accident.

Never install an inner tube inside a tubeless tyre. This will cause friction inside the tyre and the resulting heat build-up may cause the tube to burst resulting in rapid tyre deflation, loss of motorcycle control and an accident.

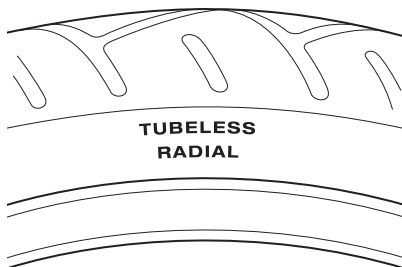

chb.1

Typical Tyre Marking - Tubeless Tyre

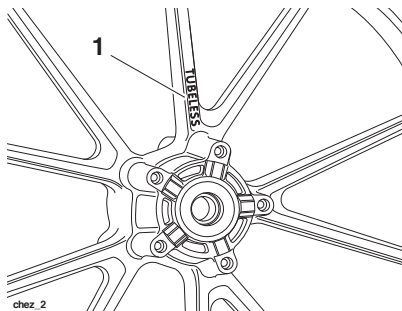

Typical Tyre Marking - Cast Wheel

Tyre Inflation Pressures

Warning

Incorrect tyre inflation will cause abnormal tread wear and instability problems that may lead to loss of control and an accident.

Under inflation may result in the tyre slipping on, or coming off the rim. Overinflation will cause instability and accelerated tread wear.

Both conditions are dangerous as they may cause loss of control leading to an accident.

Correct inflation pressure will provide maximum stability, rider comfort and tyre life. Always check tyre pressures before riding when the tyres are cold. Check tyre pressures daily and adjust if necessary. See the Specification section for details of the correct inflation pressures.

Tyre Pressure Monitoring System (TPMS) (if fitted)

Caution

An adhesive label is fitted to the wheel rim to indicate the position of the tyre pressure sensor.

Care must be taken when replacing the tyres to prevent any damage to the tyre pressure sensors.

Always have your tyres fitted by your authorised Triumph dealer and inform them that tyre pressure sensors are fitted to the wheels.

Caution

Do not use anti puncture fluid or any other item likely to obstruct air flow to the TPMS sensor's orifices. Any blockage to the air pressure orifice of the TPMS sensor during operation will cause the sensor to become blocked, causing irreparable damage to the TPMS sensor assembly.

Damage caused by the use of anti puncture fluid or incorrect maintenance is not considered a manufacturing defect and will not be covered under warranty.

Always have your tyres fitted by your authorised Triumph dealer and inform them that tyre pressure sensors are fitted to the wheels.

The tyre pressures shown on your instruments indicate the actual tyre pressure at the time of selecting the display. This may differ from the inflation pressure set when the tyres are cold because tyres become warmer during riding, causing the air in the tyre to expand and increase the inflation pressure. The cold inflation pressures specified by Triumph take account of this.

Only adjust tyre pressures when the tyres are cold using an accurate pressure gauge. Do not use the tyre pressure display on the instruments.

Maintenance

Tyre Replacement

All Triumph motorcycles are carefully and extensively tested in a range of riding conditions to ensure that the most effective tyre combinations are approved for use on each model. It is essential that approved tyres and inner tubes (if installed) fitted in approved combinations, are used when purchasing replacement items. The use of non-approved tyres and inner tubes, or approved tyres and inner tubes in non-approved combinations, may lead to motorcycle instability, loss of control and an accident.

A list of approved tyres and inner tubes specific to your motorcycle are available from your authorised Triumph dealer, or on the Internet at www.triumph.co.uk. Always have tyres and inner tubes fitted and balanced by your authorised Triumph dealer who has the necessary training and skills to ensure safe, effective fitment.

When replacement tyres or inner tubes are required, consult your authorised Triumph dealer who will arrange for the tyres and inner tubes to be selected, in a correct combination, from the approved list and fitted according to the tyre and inner tube manufacturer's instructions.

Initially, the new tyres and inner tubes will not produce the same handling characteristics as the worn tyres and inner tubes and the rider must allow adequate riding distance (approximately 100 miles (160 km)) to become accustomed to the new handling characteristics.

24 hours after fitting, the tyre pressures must be checked and adjusted, and the tyres and inner tubes examined for correct seating. Rectification must be carried out as necessary. The same checks and adjustments must also be carried out when 100 miles (160 km) have been travelled after fitting.

Warning

Inner tubes must only be used on motorcycles fitted with spoked wheels and with tyres marked 'TUBE TYPE'.

Some brands of approved tyres marked 'TUBELESS' may be suitable for use with an inner tube. Where this is the case, the tyre wall will be marked with text permitting the fitment of an inner tube.

Use of an inner tube with a tyre marked 'TUBELESS', and NOT marked as suitable for use with an inner tube, or use of an inner tube on an alloy wheel marked 'SUITABLE FOR TUBELESS TYRES' will cause deflation of the tyre resulting in loss of motorcycle control and an accident.

Warning

Do not install tube type tyres on tubeless rims.

The bead will not seat and the tyres could slip on the rims, causing rapid tyre deflation that may result in a loss of motorcycle control and an accident.

Never install an inner tube inside a tubeless tyre without the appropriate marking. This will cause friction inside the tyre and the resulting heat build-up may cause the tube to burst resulting in rapid tyre deflation, loss of motorcycle control and an accident.

Warning

If a tyre or inner tube sustains a puncture, the tyre and inner tube must be replaced.

Failure to replace a punctured tyre and inner tube, or operation with a repaired tyre or inner tube can lead to instability, loss of motorcycle control or an accident.

Warning

If tyre damage is suspected, such as after striking the kerb, ask your authorised Triumph dealer to inspect the tyre both internally and externally.

Tyre damage may not always be visible from the outside.

Operation of the motorcycle with damaged tyres could lead to loss of control and an accident.

Warning

Use of a motorcycle with incorrectly seated tyres or inner tubes, incorrectly adjusted tyre pressures, or when not accustomed to its handling characteristics may lead to loss of motorcycle control and an accident.

Warning

The ABS system operates by comparing the relative speed of the front and rear wheels.

Use of non-recommended tyres can affect wheel speed and cause the ABS function not to operate, potentially leading to loss of motorcycle control and an accident in conditions where the ABS would normally function.

Warning

Accurate wheel balance is necessary for safe, stable handling of the motorcycle. Do not remove or change any wheel balance weights. Incorrect wheel balance may cause instability leading to loss of control and an accident.

When wheel balancing is required, such as after tyre or inner tube replacement, see your authorised Triumph dealer.

Only use self-adhesive weights. Clip on weights may damage the wheel, tyre or inner tube resulting in tyre deflation, loss of motorcycle control and an accident.

Maintenance

Warning

Tyres and inner tubes that have been used on a rolling road dynamometer may become damaged. In some cases, the damage may not be visible on the external surface of the tyre.

Tyres and inner tubes must be replaced after such use as continued use of a damaged tyre or inner tube may lead to instability, loss of motorcycle control and an accident.

Warning

This motorcycle must not be operated above the legal road speed limit except in authorised closed-course conditions.

Warning

Only operate this Triumph motorcycle at high speed in closed-course, on-road competition or on closed-course racetracks.

High speed operation should only then be attempted by riders who have been instructed in the techniques necessary for high speed riding and are familiar with the motorcycle's characteristics in all conditions.

High speed operation in any other circumstances is dangerous and will lead to loss of motorcycle control and an accident.

Tyre Wear

As the tyre tread wears down, the tyre becomes more susceptible to punctures and failure. It is estimated that 90% of all tyre problems occur during the last 10% of tread life (90% worn). It is recommended that tyres are changed before they are worn to their minimum tread depth.

Minimum Recommended Tread Depth

In accordance with the periodic maintenance chart, measure the depth of the tread with a depth gauge, and replace any tyre that has worn to, or beyond, the minimum allowable tread depth specified in the table below:

Under 80 mph (130 km/h)	2 mm (0.08 in)
Over 80 mph (130 km/h)	Rear 3 mm (0.12 in) Front 2 mm (0.08 in)

Warning

Operation with excessively worn tyres is hazardous and will adversely affect traction, stability and handling which may lead to loss of motorcycle control and an accident.

When tyres become punctured, leakage is often very slow. Always inspect tyres very closely for punctures. Check the tyres for cuts, embedded nails or other sharp objects. Operation with punctured or damaged tyres will adversely affect stability and handling which may lead to loss of motorcycle control and an accident.

Check the rims for dents or deformation and spokes for looseness and damage. Operation with damaged or defective wheels, spokes or tyres is dangerous and loss of motorcycle control and an accident could result.

Always consult your authorised Triumph dealer for tyre replacement, or for a safety inspection of the wheels, spokes and tyres.

Fuses

The fuses are located under the rider's seat. To access the fuses, the rider's seat must be removed.

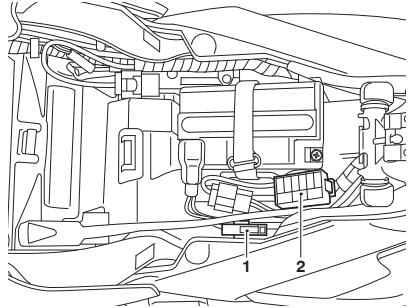

1. Main fuse
2. Fuse box

Fuse Identification

Warning

Always replace blown fuses with new ones of the correct rating (as specified on the fuse box cover) and never use a fuse of higher rating.

Use of an incorrect fuse could lead to an electrical problem, resulting in motorcycle damage, loss of motorcycle control and an accident.

A blown fuse is indicated when all of the systems protected by that fuse become inoperative. When checking for a blown fuse, use the table to establish which fuse has blown.

The fuse identification numbers listed in the table correspond with those printed on the fuse box cover, as shown below.

Maintenance

Spare fuses are located on the inside of the fuse box cover and should be replaced if used.

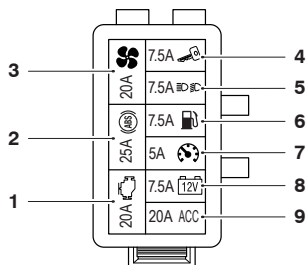

Position	Circuit Protected	Rating (Amps)
1	Ignition	7.5
2	Lighting	7.5
3	Fuel pump	7.5
4	Instruments	5
5	Battery	7.5
6	Accessories	20
7	Cooling fan	20
8	Anti-lock Braking System (ABS)	25
9	Engine management system	20

Main Fuse

The main fuse is located in a separate fuse box beneath the rider's seat. In the case of a blown fuse, this must only be replaced with a 40 Amp fuse.

Battery

Warning

The battery contains sulphuric acid (battery acid). Contact with skin or eyes may cause severe burns. Wear protective clothing and a face shield.

If battery acid gets on your skin, flush with water immediately.

If battery acid gets in your eyes, flush with water for at least 15 minutes and **SEEK MEDICAL ATTENTION IMMEDIATELY.**

If battery acid is swallowed, drink large quantities of water and **SEEK MEDICAL ATTENTION IMMEDIATELY.**

KEEP BATTERY ACID OUT OF THE REACH OF CHILDREN.

Warning

Under certain circumstance the battery may release explosive gases. Make sure to keep all sparks, flames and cigarettes away from the battery.

Do not attach jump leads to the battery, touch the battery cables together or reverse the polarity of the cables, as any of these actions may cause a spark which would ignite battery gases causing a risk of personal injury.

Make sure that there is adequate ventilation when charging or using the battery in an enclosed space.

Warning

The battery contains harmful materials. Always keep children away from the battery at all times.

Battery Removal

Warning

Make sure that the battery terminals do not touch the motorcycle frame.

This may cause a short circuit or spark which would ignite battery gases causing a risk of personal injury.

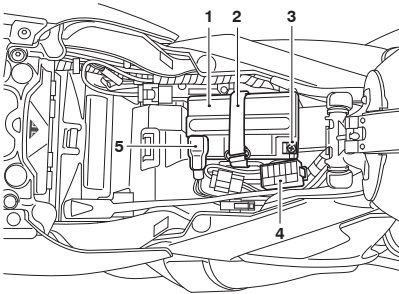

1. Battery
2. Battery strap
3. Negative (black) terminal
4. Fuse box
5. Positive (red) terminal

To remove the battery:

- Remove the seat.
- Remove the battery strap.
- Carefully remove the fuse box from the side of the battery box.

- Disconnect the battery leads, negative (black) lead first.
- Remove the battery.

Battery Disposal

Should the battery ever require replacement, the original battery must be handed to a recycling agent who will make sure that the dangerous substances from which the battery is manufactured do not pollute the environment.

Battery Maintenance

Warning

Battery acid is corrosive and poisonous and will cause damage to unprotected skin.

Never swallow battery acid or allow it to come into contact with the skin.

To prevent injury, always wear eye and skin protection when handling the battery.

The battery is a sealed type and does not require any maintenance other than checking the voltage and routine recharging when required, such as during storage.

Clean the battery using a clean, dry cloth. Make sure that the cable connections are clean.

It is not possible to adjust the battery acid level in the battery; the sealing strip must not be removed.

Maintenance

Battery Discharge

Caution

The charge level in the battery must be maintained to maximise battery life. Failure to maintain the battery charge level could cause serious internal damage to the battery.

Under normal conditions, the motorcycle charging system will keep the battery fully charged. However, if the motorcycle is unused, the battery will gradually discharge due to a normal process called self discharge; the clock, Engine Control Module (ECM) memory, high ambient temperatures, or the addition of electrical security systems or other electrical accessories will all increase this rate of battery discharge. Disconnecting the battery from the motorcycle during storage will reduce the rate of discharge.

Battery Discharge During Storage and Infrequent Use of the Motorcycle

During storage or infrequent use of the motorcycle, inspect the battery voltage weekly using a digital multimeter. Follow the manufacturer's instructions supplied with the meter.

Should the battery voltage fall below 12.7 Volts, the battery should be charged.

Allowing a battery to discharge or leaving it discharged for even a short period of time causes sulphation of the lead plates. Sulphation is a normal part of the chemical reaction inside the battery, however over time the sulphate can crystallise on the plates making recovery difficult or impossible. This permanent damage is not covered by the motorcycle warranty, as it is not due to a manufacturing defect.

Keeping the battery fully charged reduces the likelihood of it freezing in cold conditions. Allowing a battery to freeze will cause serious internal damage to the battery.

Battery Charging

Warning

The battery gives off explosive gases; keep sparks, flames and cigarettes away. Provide adequate ventilation when charging or using the battery in an enclosed space.

The battery contains sulphuric acid (battery acid). Contact with skin or eyes may cause severe burns. Wear protective clothing and a face shield.

If battery acid gets on your skin, flush with water immediately.

If battery acid gets in your eyes, flush with water for at least 15 minutes and **SEEK MEDICAL ATTENTION IMMEDIATELY.**

If battery acid is swallowed, drink large quantities of water and **SEEK MEDICAL ATTENTION IMMEDIATELY.**

KEEP BATTERY ACID OUT OF THE REACH OF CHILDREN.

Caution

Do not use an automotive quick charger as it may overcharge and damage the battery.

For help with selecting a battery charger, checking the battery voltage or battery charging, contact your local authorised Triumph dealer.

Should the battery voltage fall below 12.7 Volts, the battery should be charged using a Triumph approved battery charger. Always remove the battery from the motorcycle and follow the instructions supplied with the battery charger.

For extended periods of storage (beyond two weeks) the battery should be removed from the motorcycle and kept charged using a Triumph approved maintenance charger.

Similarly, should the battery charge fall to a level where it will not start the motorcycle, remove the battery from the motorcycle before charging.

- Refit the fuse box to the side of the battery box.
- Reconnect the battery, positive (red) lead first.
- Apply a light coat of grease to the terminals to prevent corrosion.
- Cover the positive terminal with the protective cap.
- Refit the battery strap.
- Refit the rider's seat.

Battery Installation

Warning

Make sure that the battery terminals do not touch the motorcycle frame.

This may cause a short circuit or spark which would ignite battery gases causing a risk of personal injury.

To install the battery:

- Place the battery in the battery case.

Maintenance

Headlights

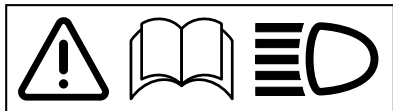

Warning

Adjust road speed to suit the visibility and weather conditions in which the motorcycle is being operated.

Make sure that the head light beam is adjusted to illuminate the road surface sufficiently far ahead without dazzling oncoming traffic.

An incorrectly adjusted headlight may impair visibility causing an accident.

Warning

Never attempt to adjust a headlight beam when the motorcycle is in motion.

Any attempt to adjust a headlight beam when the motorcycle is in motion may result in loss of control and an accident.

Caution

Do not cover the headlight or lens with any item likely to obstruct air flow to, or prevent heat escaping from, the headlight lens.

Covering the headlight lens during operation with items of clothing, luggage, adhesive tape, devices intended to alter or adjust the headlight beam or non genuine headlight lens covers will cause the headlight lens to overheat and distort, causing irreparable damage to the headlight assembly.

Damage caused by overheating is not considered a manufacturing defect and will not be covered under warranty.

If the headlight must be covered during use - such as taping of the headlight lens required during closed-course conditions - the headlight must be disconnected.

Caution

If a fault occurs with the headlight unit, then a message will be shown in the instrument display and the headlights will only be available in the dipped beam mode.

Contact an authorised Triumph dealer as soon as possible to have the fault checked and rectified.

Daytime Running Light (DRL) (if fitted)

The Daytime Running Light (DRL) is situated within the headlight assembly and is a sealed, maintenance-free LED unit. The headlight unit must be replaced in the event of the failure of the DRL.

Headlight Adjustment

The headlight unit can only be adjusted vertically. There is no horizontal adjustment.

The vertical beams of the left and right hand headlights can only be adjusted together. Independent adjustment is not possible.

The headlight unit is equipped with easily accessible adjuster bolts to allow the vertical adjustment to be corrected when the motorcycle is fully loaded.

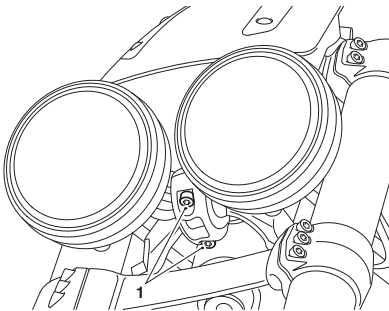

1. Headlight bracket bolts

To adjust the vertical headlight beam:

- Switch the ignition on. The engine does not need to be running.
- Switch the headlight dipped beam on.

- Loosen the headlight bracket bolts securing the headlight unit to the headlight bracket sufficiently to allow restricted movement of the headlights.

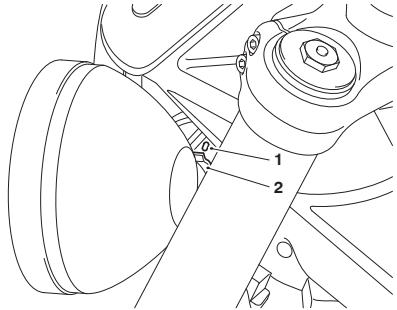

1. Front subframe alignment mark
2. Headlight bracket mark

- Move the headlight unit downwards or upwards to adjust the headlight beam accordingly.
- To return the headlight alignment to the factory standard position, move the headlight unit until the front subframe alignment mark and the headlight bracket mark are aligned.
- Tighten the headlight bracket bolts to 15 Nm.
- Recheck the headlight beam settings.
- Switch the headlights off when the headlight beam settings are satisfactory.

Maintenance

Bulb Replacement

Caution

The use of non-approved bulbs may result in damage to lenses and other lighting unit components.

In addition, the use of bulbs of incorrect wattage may cause the chassis ECM to cut power to affected lighting circuits.

Use genuine Triumph supplied bulbs as specified in the Triumph Parts Catalogue.

Always have replacement bulbs installed by an authorised Triumph dealer.

Headlights

The headlight unit is a sealed, maintenance free LED unit. The headlight unit must be replaced in the event of the failure of the headlight.

Direction Indicator Lights

The motorcycle is fitted with either LED or bulb direction indicator lights.

LED Direction Indicator Lights

The direction indicator light units are sealed, maintenance free LED units.

Bulb Direction Indicator Lights

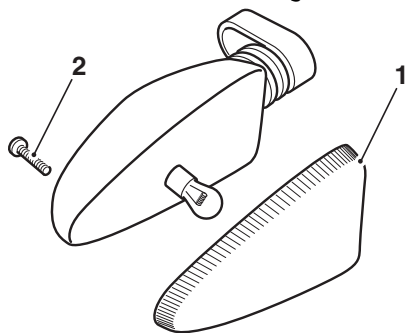

celc_2

1. Indicator lens
2. Screw

To replace the direction indicator light bulb:

- The lens on each indicator light is held in place by a screw located in the body of the light.
- Release the indicator lens screw.
- Remove the lens to gain access to the bulb for replacement.
- Replace the bulb.
- Refit the lens making sure that the locating tang is correctly aligned to the indicator body.
- Tighten the indicator lens screw to 1 Nm.

License Plate Light

The license plate light unit is a sealed, maintenance free LED unit.

Rear Light

The rear light unit is a sealed, maintenance free LED unit.

Mirrors

Warning

Operation of the motorcycle with incorrectly adjusted mirrors is dangerous.

Operation of the motorcycle with incorrectly adjusted mirrors will result in loss of vision to the rear of the motorcycle. It is dangerous to ride a motorcycle without sufficient rearward vision.

Always adjust the mirrors to provide sufficient rearward vision before riding the motorcycle.

Warning

Never attempt to clean or adjust mirrors while riding the motorcycle. Removal of the rider's hands from the handlebars while riding the motorcycle will diminish the ability of the rider to maintain control of the motorcycle.

Attempting to clean or adjust mirrors while riding the motorcycle may result in loss of control of the motorcycle and an accident.

Only attempt to clean or adjust the mirrors while stationary.

Warning

Incorrect adjustment of the bar end mirrors may cause the mirror arm to contact the fuel tank, brake or clutch levers or other parts of the motorcycle.

This will restrict brake or clutch lever operation or restrict steering movement, resulting in loss of motorcycle control and an accident.

Adjust the mirrors as required to make sure they do not contact any part of the motorcycle. After adjustment, move the handlebar to the left and right full lock while checking that the mirrors do not contact the fuel tank, brake or clutch levers or other parts of the motorcycle.

Caution

Incorrect adjustment of the bar end mirrors may cause the mirror arm to contact the fuel tank, brake or clutch levers or other parts of the motorcycle.

This will result in damage to the fuel tank, brake or clutch levers or other parts of the motorcycle.

Adjust the mirrors as required to make sure they do not contact any part of the motorcycle. After adjustment, move the handlebar to the left and right full lock while checking that the mirrors do not contact the fuel tank, brake or clutch levers or other parts of the motorcycle.

Maintenance

The bar end mirrors will be set by your authorised Triumph dealer and will not normally require any adjustment. Should adjustment be necessary, do not rotate the mirror beyond 75°, measured from the vertical section of the mirror arm.

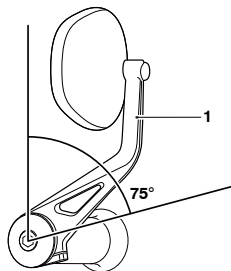

1. Mirror arm vertical section

Jacking Points

Warning

This motorcycle is fitted with jacking points on the engine sump.

Use of the jacking points requires specialist lifting equipment.

Attempting to lift the motorcycle without using the jacking points, or without using the correct lifting equipment, may result in the motorcycle falling, causing injury to the operator or damage to the motorcycle.

Jacking or lifting of this motorcycle should only be carried out by an authorised Triumph dealer, who will have the correct training and lifting equipment to safely lift the motorcycle.

The jacking points are located on the engine sump.

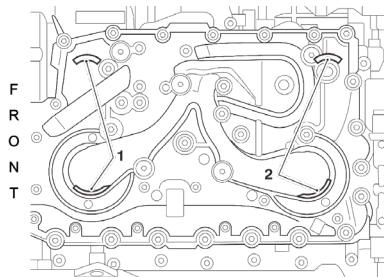

1. Front jacking points
2. Rear jacking points

Cleaning and Storage

Table of Contents

Preparation for Washing.....	156
Where to be Careful.....	156
Washing.....	157
After Washing.....	157
Care of Matt Paintwork.....	158
Care of Gloss Paintwork.....	158
Aluminium Items - not Lacquered or Painted.....	158
Cleaning of Chrome and Stainless Steel Items.....	159
Black Chrome.....	159
Cleaning of the Exhaust System.....	160
Seat Care.....	161
Care of Leather Seat.....	161
Care of Leather Products.....	162
Windscreen Cleaning (if fitted).....	163
Preparation for Storage.....	164
Preparation after Storage.....	165

Cleaning and Storage

Preparation for Washing

Before washing, precautions must be taken to keep water off the following places.

Rear opening of the exhausts: Cover with a plastic bag secured with rubber bands.

Clutch and brake levers, switch housings on the handlebar: Cover with plastic bags.

Ignition switch and steering lock: Cover the keyhole with tape.

Remove any items of jewellery such as rings, watches, zips or belt buckles, which may scratch or otherwise damage painted or polished surfaces.

Use separate cleaning sponges or cleaning cloths for washing painted/polished surfaces and chassis areas. Chassis areas (such as wheels and under mudguards) will be exposed to more abrasive road grime and dust, which may then scratch painted or polished surfaces, if the same sponge or cleaning cloths are used.

Where to be Careful

Caution

Do not spray any water at all near the air intake duct.

The air intake duct is normally located under the rider's seat, under the fuel tank or near the steering head.

Any water sprayed in this area could enter the airbox and engine, causing damage to both items.

Caution

Use of high pressure spray washers is not recommended.

When using pressure washers, water may be forced into bearings and other components causing premature wear from corrosion and loss of lubrication.

Avoid spraying water with any great force near the following places:

- Instruments,
- Brake cylinders and brake calipers,
- Under the fuel tank,
- Air intake duct,
- Headstock bearings,
- Wheel bearings,
- Suspension seals and bearings.

Note

Use of soaps that are highly alkaline will leave a residue on painted surfaces, and may also cause water spotting.

Always use a low alkaline soap to aid the cleaning process.

Washing

To wash the motorcycle, do the following:

- Prepare a mixture of cold water and mild automotive cleaner. Do not use a highly alkaline soap as commonly found at commercial car washes because it leaves a residue.
- Wash the motorcycle with a sponge or soft cloth. Do not use abrasive scouring pads or steel wool. They will damage the finish.
- Rinse the motorcycle thoroughly with cold water.

After Washing

Warning

Never wax or lubricate the brake discs. Waxed or lubricated brake discs may cause loss of braking power and an accident.

Always clean the brake disc with a proprietary brand of oil-free brake disc cleaner.

After washing the motorcycle, do the following:

1. Remove the plastic bags and tape, and clear the air intakes.
2. Lubricate the pivots, bolts and nuts.
3. Test the brakes before motorcycle operation.
4. Use a dry cloth or chamois leather to absorb water residue. Do not allow water to stand on the motorcycle as this will lead to corrosion.
5. Start the engine and run it for 5 minutes. Make sure that there is adequate ventilation for the exhaust fumes.

Cleaning and Storage

Care of Matt Paintwork

Matt paintwork requires no greater care than that already recommended for high gloss paintwork.

- Do not use any polish or wax on matt paintwork.
- Do not try and polish out scratches.

Care of Gloss Paintwork

Gloss paintwork should be washed and dried as described above, then protected using a high quality automotive polish. Always follow the manufacturer's instructions and repeat regularly to maintain your motorcycle's appearance.

Aluminium Items - not Lacquered or Painted

Items such as brake and clutch levers, wheels, engine covers, engine cooling fins, upper and lower yokes and throttle bodies on some models must be correctly cleaned to preserve their appearance. Please contact your dealer if you are unsure which components on your motorcycle are aluminium parts not protected by paint or lacquer, and for guidance on how to clean those items.

Use a proprietary brand of aluminium cleaner which does not contain abrasive or caustic elements.

Clean aluminium items regularly, in particular after use in inclement weather, where the components must be hand washed and dried each time the machine is used.

Warranty claims due to inadequate maintenance will not be allowed.

Cleaning of Chrome and Stainless Steel Items

All chrome and stainless steel parts of your motorcycle must be cleaned regularly to avoid a deterioration of its appearance.

Washing

Wash as previously described.

Drying

Dry the chrome and stainless steel parts as far as possible with a soft cloth or chamois leather.

Protecting

**Caution**

The use of products containing silicone will cause discolouration of the chrome and stainless steel parts and must not be used. Similarly, the use of abrasive cleaners will damage the finish and must not be used.

When the chrome and stainless steel is dry, apply a suitable proprietary chrome cleaner on to the surface, following the manufacturer's instructions.

It is recommended that regular protection be applied to the motorcycle as this will both protect and enhance its appearance.

Black Chrome

Items such as headlight bowls and mirrors on some models must be correctly cleaned to preserve their appearance. Please contact your dealer if you are unsure which components on your motorcycle are black chrome parts. Maintain the appearance of black chrome items by rubbing a small amount of light oil into the surface.

Cleaning and Storage

Cleaning of the Exhaust System

All parts of the exhaust system of your motorcycle must be cleaned regularly to avoid a deterioration of its appearance. These instructions can be applied to chrome, brushed stainless steel and carbon fibre components; matt painted exhaust systems should be cleaned as above, noting the care instructions in the Matt Paintwork section previously.

Note

The exhaust system must be cool before washing to prevent water spotting.

Washing

Wash as previously described.

Make sure that no soap or water enters the exhausts.

Drying

Dry the exhaust system as far as possible with a soft cloth or chamois leather. Do not run the engine to dry the system or spotting will occur.

Protecting

Caution

The use of products containing silicone will cause discolouration of the chrome and must not be used. Similarly, the use of abrasive cleaners will damage the system and must not be used.

When the exhaust system is dry, apply a suitable proprietary motorcycle protection spray onto the surface, following the manufacturer's instructions.

It is recommended that regular protection be applied to the system as this will both protect and enhance the system's appearance.

Seat Care

Caution

Use of chemicals or high pressure spray washers is not recommended for cleaning the seat.

Using chemicals or high pressure spray washers may damage the seat cover.

To help maintain its appearance, clean the seat using a sponge or cleaning cloth with soap and water.

Care of Leather Seat

Caution

Use of chemicals or high pressure spray washers is not recommended for cleaning the seat.

Using chemicals or high pressure spray washers may damage the seat cover.

It is recommend that the leather seat is periodically cleaned with a damp cloth and allowed to dry naturally at room temperature. This will maintain the appearance of the leather and ensure the long life of the seat.

The Triumph leather seat is a natural product and lack of care can result in damage and permanent wear. Follow these simple instructions to prolong the life of the leather seat:

- Do not use household cleaning products, bleach, detergents containing bleach or any kind of solvent to clean the leather seat.
- Do not immerse the leather seat in water.
- Avoid direct heat from fires and radiators which can dry out and distort the leather.
- Do not leave the leather seat in direct sunlight for prolonged periods of time.
- Do not dry the leather seat by applying direct heat to it at any time.
- If the leather seat does get wet, absorb any excess water with a soft clean cloth then leave the seat to dry naturally at room temperature.

Cleaning and Storage

- Avoid exposure of the leather seat to high levels of salt, for example sea/salt water or road surfaces that have been treated during the winter for ice and snow.
- If exposure to salt is unavoidable, clean the leather seat immediately after each exposure using a damp cloth then leave the seat to dry naturally at room temperature.
- Gently clean any minor marks with a damp cloth then leave the seat to dry naturally at room temperature.
- Cover the leather seat with the seat cover to protect it when in storage. Do not use a plastic bag.

Care of Leather Products

It is recommended that the leather products are periodically cleaned with a damp cloth and allowed to dry naturally at room temperature. This will maintain the appearance of the leather and ensure the long life of the product.

The Triumph leather product is a natural product and lack of care can result in damage and permanent wear.

Follow these simple instructions to prolong the life of the leather product:

- Do not use household cleaning products, bleach, detergents containing bleach or any kind of solvent to clean the leather product.
- Do not immerse the leather product in water.
- Avoid direct heat from fires and radiators which can dry out and distort the leather.
- Do not leave the leather product in direct sunlight for prolonged periods of time.
- Do not dry the leather product by applying direct heat to it at any time.
- If the leather product does get wet, absorb any excess water with a soft clean cloth then leave the leather product to dry naturally at room temperature.
- Avoid exposure of the leather product to high levels of salt, for example sea/salt water or road surfaces that have been treated during the winter for ice and snow.

- If exposure to salt is unavoidable, clean the leather product immediately after each exposure using a damp cloth then leave the leather product to dry naturally at room temperature.
- Gently clean any minor marks with a damp cloth then leave the leather product to dry naturally at room temperature.
- Place the leather product in a fabric bag or cardboard box to protect it when in storage. Do not use a plastic bag.

Windscreen Cleaning (if fitted)



Warning

Never attempt to clean the windscreen while the motorcycle is in motion as releasing the handlebars may cause loss of motorcycle control and an accident.

Operation of the motorcycle with a damaged or scratched windscreen will reduce the rider's forward vision. Any such reduction in forward vision is dangerous and may lead to loss of motorcycle control and an accident.

Caution

Corrosive chemicals such as battery acid will damage the windscreen. Never allow corrosive chemicals to contact the windscreen.

Caution

Products such as window cleaning fluids, insect remover, rain repellent, scouring compounds, petrol or strong solvents such as alcohol, acetone, carbon tetrachloride, etc. will damage the windscreen.

Never allow these products to contact the windscreen.

Cleaning and Storage

Clean the windscreen with a solution of mild soap or detergent and cold water.

After cleaning, rinse well and then dry with a soft, lint-free cloth.

If the transparency of the windscreen is reduced by scratches or oxidation which cannot be removed, the windscreen must be replaced.

Preparation for Storage

To prepare the motorcycle for storage, do the following:

- Clean and dry the entire vehicle thoroughly.
- Fill the fuel tank with the correct grade of unleaded fuel and add a fuel stabiliser (if available), following the fuel stabiliser manufacturer's instructions.



Warning

Petrol is extremely flammable and can be explosive under certain conditions.

Turn the ignition switch off. Do not smoke.

Make sure the area is well ventilated and free from any source of flame or sparks; this includes any appliance with a pilot light.

- Remove the spark plug from each cylinder and put several drops (5 ml) of engine oil into each cylinder. Cover the spark plug holes with a piece of cloth or rag. With the engine stop switch in the RUN position, push the starter button for a few seconds to coat the cylinder walls with oil. Install the spark plugs, tightening to 12 Nm.
- Change the engine oil and filter (see page 121).
- Check and if necessary correct the tyre pressures.

- Set the motorcycle on a stand so that both wheels are raised off the ground. (If this cannot be done, put boards under the front and rear wheels to keep dampness away from the tyres.)
- Spray rust inhibiting oil (there are a host of products on the market and your dealer will be able to offer you local advice) on all unpainted metal surfaces to prevent rusting. Prevent oil from getting on rubber parts, brake discs or in the brake calipers.
- Make sure the cooling system is filled with a 50% mixture of coolant (noting that HD4X Hybrid OAT coolant, as supplied by Triumph, is premixed and requires no dilution) and distilled water solution (see page 124).
- Remove the battery, and store it where it will not be exposed to direct sunlight, moisture, or freezing temperatures. During storage it should be given a slow charge (one ampere or less) approximately once every two weeks (see page 146).
- Store the motorcycle in a cool, dry area, away from sunlight, and with a minimum daily temperature variation.
- Put a suitable porous cover over the motorcycle to keep dust and dirt from collecting on it. Avoid using plastic or similar non-breathable, coated materials that restrict air flow and allow heat and moisture to accumulate.

Preparation after Storage

To prepare the motorcycle after storage, do the following:

- Install the battery (if removed) (see page 149).
- If the motorcycle has been stored for more than four months, change the engine oil (see page 121).
- Check all the points listed in the Daily Safety Checks section.
- Before starting the engine, remove the spark plugs from each cylinder.
- Put the side stand down.
- Crank the engine on the starter motor several times until the oil pressure light goes out.
- Refit the spark plugs, tightening to 12 Nm, and start the engine.
- Check and if necessary correct the tyre pressures.
- Clean the entire vehicle thoroughly.
- Check the brakes for correct operation.
- Test ride the motorcycle at low speeds.

This page intentionally left blank

Specifications

Dimensions, Weights and Performance

A list of model specific dimensions, weights and performance figures is available from your authorised Triumph dealer, or on the Internet at www.triumph.co.uk.

Payload

Maximum Payload

Rocket 3 TFC

208 kg (458 lb)

Engine

Type

Rocket 3 TFC

Liquid cooled in-line 3 cylinder

Displacement

2458 cc

Bore x Stroke

110.2 x 85.9 mm

Compression Ratio

10.9:1

Cylinder Numbering

Front to back

Cylinder Sequence

1 at front

Firing Order

1-3-2

Starting System

Electric starter

Lubrication

Lubrication System

Rocket 3 TFC

Dry sump

Engine Oil Capacities:

Dry Fill

5.2 litres

Oil/Filter Change

4.6 litres

Oil Change Only

4.4 litres

Cooling

Coolant Type

Rocket 3 TFC

Triumph HD4X Hybrid OAT

Water/Coolant Ratio

50/50 (pre-mixed as supplied by Triumph)

Coolant Capacity

2.6 litres

Thermostat Opens

88°C +/- 2°C

Fuel System

Type

Rocket 3 TFC

Electronic fuel injection

Fuel Pump

Submerged electric

Fuel Pressure (nominal)

3.5 bar

Specifications

Fuel

Type
Tank Capacity

Rocket 3 TFC

95 RON unleaded
19 litres

Ignition

Ignition System
Spark Plug
Spark Plug Gap

Rocket 3 TFC

Digital Inductive
NGK LMAR8A-9
0.9 mm +0.0/-0.1 mm

Transmission

Transmission Type
Clutch Type
Final Drive Chain
Primary Drive Ratio
Gear Ratio:

Rocket 3 TFC

6 speed, constant mesh
Wet, multi-plate
Bevel geared crown wheel and pinion
1.246:1 (71/57)
2.389:1 (43/18)
1.840:1 (46/25)
1.414:1 (41/29)
1.121:1 (37/33)
0.972:1 (35/36)
0.838:1 (31/37)
2.846:1 (37/13)



Warning

Use the recommended tyres **ONLY** in the combinations given.

Do not mix tyres from different manufacturers or mix different specification tyres from the same manufacturers as this may result in loss of motorcycle control and an accident.

Approved Tyres

A list of approved tyres specific to these models is available from your authorised Triumph dealer, or on the Internet at www.triumph.co.uk.

Tyres

Tyre Sizes:

Front

150/80 R17

Rear

240/50 R16

Tyre Pressures (Cold):

Front

2.9 bar (42 lb/in²)

Rear

2.9 bar (42 lb/in²)

Electrical Equipment

Battery Type

YTX20CH-BS

Battery Rating

12 Volt, 18.9 Ah

Alternator

14 Volt, 45 Amp at 3,000 rpm

Directional Indicator Lights

LED

Headlight

LED

License Plate Light

LED

Tail/Brake Light

LED

Frame

Rake

28°

Trail

135.4 mm (5.33 in)

Tightening Torques

Battery Terminals

4.5 Nm

Clutch Lever Nut

3.5 Nm

Clutch Fluid Reservoir Cap Screws

1.5 Nm

Front Brake Fluid Reservoir Cap Screws

1.5 Nm

Final Drive Unit Oil Filler Plug

25 Nm

Oil Filter

10 Nm

Radiator Cap Screws

1 Nm

Radiator Lower Surround

5 Nm

Rear Brake Fluid Reservoir Cap Screws

2 Nm

Rear Wheel Nuts

110 Nm

Spark Plug

12 Nm

Sump Plugs

25 Nm

Specifications

Fluids and Lubricants

Bearings and Pivots

Brake Fluid

Coolant

Engine Oil

Final Drive Oil

Rocket 3 TFC

Grease to NLGI 2 specification

DOT 4 brake fluid

Triumph HD4X Hybrid OAT coolant (pre-mixed)

Semi or fully synthetic 15W/50 motorcycle engine oil which meets specification API SH (or higher) and JASO MA, such as Castrol Power 1 4T.

75W/90 fully synthetic hypoid oil that meets specification API Service Level GL5, such as Castrol SAF-XO fully synthetic hypoid oil.

Index

A	
Accessories.....	109
Ambient Air Temperature	
Warning Light.....	29
Anti-lock Braking System (ABS).....	101
ABS Warning Light.....	102
Indicator Light.....	26
Optimised Cornering ABS.....	101
B	
Backrest.....	85
Adjustment.....	85
Battery.....	147
Charging.....	149
Discharge.....	148
Disposal.....	147
Installation.....	149
Maintenance.....	147
Removal.....	147
Storage.....	148
Brakes.....	129
Anti-lock Braking System (ABS).....	101
Brake Light.....	133
Braking.....	97
Breaking-in New Brake Pads and Discs.....	130
Disc Brake Fluid.....	131
Front Brake Fluid Level Adjustment.....	132
Front Brake Fluid Level Inspection.....	132
Optimised Cornering ABS.....	101
Pad Wear Compensation.....	130
Rear Brake Fluid Level Adjustment.....	133
Rear Brake Fluid Level Inspection.....	133
Wear Inspection.....	129
Bulb Replacement.....	152
C	
Cleaning	
After Washing.....	157
Aluminium Items - not Lacquered or Painted.....	158
Black Chrome Items.....	159
Care of Leather Products.....	162
Care of Leather Seat.....	161
Chrome and Stainless Steel.....	159
Drying.....	160
Exhaust System.....	160
Gloss Paintwork.....	158
Matt Paintwork.....	158
Preparation for Washing.....	156
Protecting.....	160
Seat Care.....	161
Washing.....	157
Washing the Exhaust.....	160
Where to be Careful.....	156
Windscreen.....	163
Clutch.....	127
Fluid Level Adjustment.....	128
Fluid Level Inspection.....	128
Inspection.....	128
Considerations for High-Speed Operation.....	107
Cooling System.....	124
Coolant Change.....	126
Coolant Level Adjustment.....	125
Coolant Level Inspection.....	125
Coolant Temperature.....	39
Corrosion Inhibitors.....	124
Specifications.....	167
Cruise Control	
Activating.....	72
Cruise Control Adjust Button.....	66
Deactivating.....	72
D	
Daytime Running Lights (DRL).....	28
Direction Indicator Lights.....	152
Replacement.....	152
Direction Indicators	
Mode Selection.....	45
Warning Light.....	27
E	
Electrical Accessory Socket.....	89
Electrical Equipment	
Specifications.....	169

Index

Engine	
Moving Off	95
Serial Number	19
Specifications	167
Starting the Engine	94
Stopping the Engine	94
Engine Oil	119
Disposal of Oil and Filters	123
Engine Oil Change	121
Low Oil Pressure Warning Light	25
Oil Filter Change	121
Oil Level Inspection	119
Specification and Grade	123
Engine Start/Stop Switch	
QUICK START Position	66
RUN Position	66
STOP Position	65
F	
Final Drive Unit	128
Oil Level Adjustment	128
Fluids	
Specifications	170
Footrests	
Adjustable	87
Passenger	86
Frame	
Specifications	169
Front Fork Inspection	135
Front Suspension	
Compression Damping Adjustment	136
Rebound Damping Adjustment	137
Fuel	
Filling the Fuel Tank	81
Fuel Grade	78
Fuel Tank Cap	80
Gauge	30
Low Fuel Warning Light	28
Refuelling	79
Specifications	168
Status Information	38
System Specifications	167
Fuel Tank Cap	80
Fuses	145
Identification	145
Main Fuse	146
G	
Gears	
Changing Gears	96
Gear Position Display	31
Shift Indicator Display	51
H	
Hazards	
Warning Lights	27
Headlights	
Adjustment	151
Daytime Running Lights (DRL)	151
Replacement	152
High Beam	
Indicator Light	27
Hill Hold Control	103
Activation	104
Deactivation	104
Unavailable Message	105
HOME Button	66
I	
Ignition	
Keyless	63
Smart Key	61
Specifications	168
Immobiliser	
Indicator Light	26
Instruments	
Clock Display	54
Contrast	36
Coolant Temperature	39
Date Display	54
Detail	37
Display Brightness	50
Display Set Up	50
Fuel Gauge	30
Fuel Status	38
Gear Position Display	31
Information Tray	35
Language Options	53

Main Menu	41	Mirrors	
Odometer	29, 40	Bar End Mirrors	154
Panel Adjustment	57	O	
Panel Display	23	Odometer	40
Reset To Defaults	55	Owner's Handbook	89
Rider Name Display	52	P	
Riding Modes	32	Parking	106
Service Indicator	40	Parts Identification	
Shift Indicator	51	Left Hand Side	16
Speedometer	29	Rider View	18
Tachometer	30	Right Hand Side	17
Themes	37, 50	Passengers	112
Trip Meters	38	Payload	
Tyre Pressure Monitoring System (TPMS)	40	Specifications	167
Units Display	53	R	
Visible Tray	51	Rear Light	152
Warning Lights	25	Rear Suspension	
Warnings and Messages	35	Rebound Damping Adjustment	138
		Spring Preload Adjustment	138
J		Riding Modes	32
Jacking Points	154	Configuration	43
Joystick Button	68	Selection	32
K		Settings	42
Keyless Ignition	63	Right Handlebar Switches	65
Keys	61	Daytime Running Lights (DRL) Switch	66
L		Hazard Warning Lights	65
Left Handlebar Switches	66	Running-In	91
Direction Indicator Switch	67	S	
Heated Grips Switch	68	Safety	
High Beam Button	68	Daily Checks	92
Horn Button	68	Fuel and Exhaust Fumes	8
MODE Button	67	Handlebars and Footrests	10
Brakes	70	Helmet and Clothing	9
License Plate Light	152	Maintenance and Equipment	11
Loading	110	Motorcycle	7
Lubrication		Parking	12
Specifications	167	Parts and Accessories	12
M		Riding	9
Maintenance		Seats	
Scheduled Maintenance	115	Backrest	85
Scheduled Maintenance Table	117	Configuration	84
Master Ignition Switch	64		

Index

Cover	85	Trip Meters	38
Install	83, 84	Automatic Reset	49
Removal	83, 83	Manual Reset	48
Rider	83	Set Up	48
Rider and Passenger	83	Trip 2 Enable/Disable	49
Seat Care	82, 161	Triumph Shift Assist (TSA)	96
Seat Lock	82	Tyre Pressure Monitoring System (TPMS)	75
Storage	85	Instruments	40
Service		Low Tyre Pressure	78
Indicator Announcement	40	Sensor Batteries	76
Interval Set Up	46	Sensor Serial Number	75
Side Panels	81	System Fault	77
Side Stand	88	Tyre Pressure Warning Light	76
Smart Key	61	Tyre Pressures	77, 141
Battery Replacement	62	Tyres	4, 140
Operation	63	Low Tyre Pressure	78
Steering		Minimum Recommended Tread Depth	144
Front Fork Inspection	135	Replacement	142
Inspection	134	Specifications	169
Steering Lock		Tyre Inflation Pressures	141
Steering Lock Button	65	Tyre Pressures	77
Storage		Tyre Wear	144
Preparation after Storage	165		
Preparation for Storage	164	U	
Suspension		Universal Serial Bus (USB) Socket	90
Front Settings	136	V	
Rear Settings	137	Vehicle Identification Number	19
T		W	
Themes		Warnings	3
Set Up	50	Immobiliser and TPMS	4
Throttle Control	69, 127, 127	Maintenance	3
Brake Use	70	Noise Control System	4
Tool Kit	89	Owner's Handbook	5
Torque		Warning Label Locations	14
Specifications	169	Warning Labels	3
Traction Control (TC)	73	Warning Lights	25
Disabled Warning Light	27	Wheel Bearings	
Enable/Disable	46	Inspection	135
Indicator Light	26	Windscreen	88
Optimised Cornering Traction Control	74		
Settings	74		
Transmission			
Specifications	168		

Approval Information

This section contains approval information that is required to be included in this Owner's Handbook.

Radio Equipment Device EU Directive 2014/53

Triumph motorcycles are equipped with a range of radio equipment devices. These radio equipment devices must comply with the EU Radio Equipment Device Directive 2014/53/EU. The complete text of the EU declaration of conformity for each radio equipment device is available at the following address:

www.triumphmotorcycles.co.uk/public-content/triumph-radio-device-approvals

Approval Information

The table below shows the frequencies and power levels for the radio equipment devices in compliance with the EU Directive 2014/53/EU. The table shows all radio equipment devices used across the Triumph range of motorcycles. Only certain radio equipment devices in the table are applicable to specific motorcycles.

Radio Equipment Device	Frequency Range	Maximum Transmit Power Level	Manufacturer
Chassis Control Unit	Receive Bands: 433.92 MHz, 134.2 kHz Category-2 Receiver Transmit Bands: 134.2 kHz Class 1 Transmitter Fixed Inductive Loop Coil Antenna	287 nW ERP	Pektron Alfreton Road, Derby, DE21 4AP UK
Keyless Control Unit	Receive Bands: 433.92 MHz, 134.2 kHz Category-2 Receiver Transmit Bands: 134.2 kHz Class 1 Transmitter Fixed Inductive Loop Coil Antenna	6.28 uW ERP	
Keyless Control Unit 2	Receive Bands: 433.92 MHz, 134.2 kHz Category-2 Receiver Transmit Bands: 134.2 kHz Class 1 Transmitter Fixed Inductive Loop Coil Antennas	3.01 uW ERP	
Keyless System Key Fob	Receive Bands: 134.2 kHz Category-2 Receiver Transmit Bands: 433.92 MHz, 134.2 kHz Class: N/A Antenna Type Fixed Antenna (PCB)	0.019 mW ERP	

Approval Information

Radio Equipment Device	Frequency Range	Maximum Transmit Power Level	Manufacturer
Immobiliser (Motorcycles with Key System)	Receive Bands: 433.92 MHz, 125 kHz Transmit Bands: 120.9 KHz to 131.3 KHz	5dB A/m @ 10m	LDL Technology Parc Technologique Du Canal,
Tyre Pressure Monitoring System (TPMS)	Receive Bands: None Transmit Bands: 433.97 MHz to 433.87 MHz	0.063 mW	3 Rue Giotto, 31520 Ramonville Saint-Agne, France
Triumph Accessory Alarm System ECU	Receive Bands: 433.92 MHz Transmit Bands: None	N/A	Scorpion Automotive Ltd Drumhead Road,
Triumph Accessory Alarm System Remote/Key Fob	Receive Bands: None Transmit Bands: 433.92 MHz	10 mW ERP	Chorley North Business Park, Chorley, PR6 7DE UK

Representative within the European Union

Address

Triumph Motocicletas Espana S.L.
C/Cabo Rufino Lazaro
14 - E
28232 - Las Rozas De Madrid
Spain

Approval Information

This page intentionally left blank