

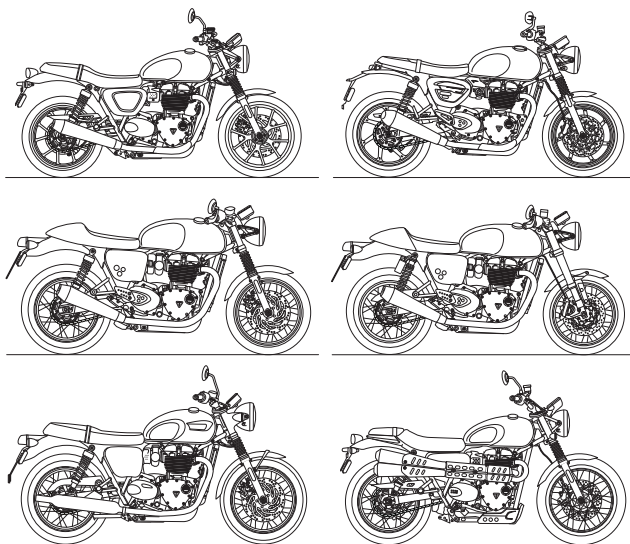

Owner's Handbook

Bonneville T100, Bonneville T120, Bonneville T120 Ace, Bonneville T120 Diamond, Speed Twin, Street Scrambler, Street Twin, Thruxton and Thruxton R



This handbook contains information on the Triumph Bonneville T100, Bonneville T120, Bonneville T120 Ace, Bonneville T120 Diamond, Speed Twin, Street Scrambler, Street Twin, Thruxton and Thruxton R motorcycles. Always store this Owner's Handbook with the motorcycle and refer to it for information whenever necessary.

The information contained in this publication is based on the latest information available at the time of printing. Triumph reserves the right to make changes at any time without prior notice, or obligation.

Not to be reproduced wholly or in part without the written permission of Triumph Motorcycles Limited.

© Copyright 11.2018 Triumph Motorcycles Limited, Hinckley, Leicestershire, England.

Publication part number 3855598-EN issue 1

Table of Contents

This handbook contains a number of different sections. The table of contents below will help you find the beginning of each section where, in the case of the major sections, a further table of contents will help you find the specific subject required.

Foreword.....	3
Safety First.....	7
Warning Label Locations.....	14
Parts Identification.....	16
Serial Numbers.....	29
General Information.....	31
How to Ride the Motorcycle.....	79
Accessories, Loading and Passengers.....	93
Maintenance and Adjustment.....	97
Cleaning and Storage.....	149
Specifications - Bonneville T100 and Bonneville T120.....	159
Specifications - Bonneville T120 Ace and Diamond.....	163
Specifications - Street Scrambler.....	167
Specifications - Speed Twin.....	171
Specifications - Street Twin.....	175
Specifications - Thruxton and Thruxton R.....	179
Index.....	183
Approval Information.....	187

Foreword

Warnings, Cautions and Notes

Throughout this Owner's Handbook particularly important information is presented in the following form:

Warning

This warning symbol identifies special instructions or procedures, which if not correctly followed could result in personal injury, or loss of life.

Caution

This caution symbol identifies special instructions or procedures, which, if not strictly observed, could result in damage to, or destruction of, equipment.

Note

This note symbol indicates points of particular interest for more efficient and convenient operation.

Warning Labels



At certain areas of the motorcycle, the symbol (above) can be seen. The symbol means 'CAUTION: REFER TO THE HANDBOOK' and will be followed by a pictorial representation of the subject concerned.

Never attempt to ride the motorcycle or make any adjustments without reference to the relevant instructions contained in this handbook.

See page 14 for the location of all labels bearing this symbol. Where necessary, this symbol will also appear on the pages containing the relevant information.

Maintenance

To ensure a long, safe and trouble free life for your motorcycle, maintenance should only be carried out by an authorised Triumph dealer.

Only an authorised Triumph dealer will have the necessary knowledge, equipment and skills to maintain your Triumph motorcycle correctly.

To locate your nearest authorised Triumph dealer, visit the Triumph web site at www.triumph.co.uk or telephone the authorised distributor in your country. Their address is given in the service record book that accompanies this handbook.

Noise Control System

Tampering with the noise control system is prohibited.

Owners are warned that the law may prohibit:

Foreword

1. The removal or rendering inoperative by any person other than for purposes of maintenance, repair or replacement, of any device or element of design incorporated into any new vehicle for the purpose of noise control prior to its sale or delivery to the ultimate purchaser or while it is in use and,
2. the use of the vehicle after such device or element of design has been removed or rendered inoperative by any person.

Among those acts presumed to constitute tampering are the acts listed below:

- Removal of, or puncturing the muffler, baffles, header pipes or any other component which conducts exhaust gases.
- Removal of, or puncturing of any part of the intake system.
- Lack of proper maintenance.
- Replacing any moving parts of the vehicle, or parts of the exhaust or intake system, with parts other than those specified by the manufacturer.

Immobiliser and Tyre Pressure Monitoring System

This device complies with part 15 of the Federal Communications Commission (FCC) Rules.

Operation is subject to the following two conditions:

1. This device may not cause harmful interference.

2. This device must accept any interference received, including interference that may cause undesired operation.

Changes or modifications to the device could void the user's authority to operate the equipment.

Tyres

With reference to the Pneumatic Tyres and Tubes for Automotive Vehicles (Quality Control) Order, 2009, Cl. No. 3 (c), it is declared by M/s. Triumph Motorcycles Ltd. that the tyres fitted on this motorcycle meet the requirements of IS 15627: 2005 and comply with the requirements under Central Motor Vehicle Rules (CMVR), 1989.

Owner's Handbook

Warning

This Owner's Handbook, and all other instructions that are supplied with your motorcycle, should be considered a permanent part of your motorcycle and should remain with it even if your motorcycle is subsequently sold.

All riders must read this Owner's Handbook and all other instructions which are supplied with your motorcycle, before riding, in order to become thoroughly familiar with the correct operation of your motorcycle's controls, its features, capabilities and limitations. Do not lend your motorcycle to others as riding when not familiar with your motorcycle's controls, features, capabilities and limitations can lead to an accident.

Thank you for choosing a Triumph motorcycle. This motorcycle is the product of Triumph's use of proven engineering, exhaustive testing, and continuous striving for superior reliability, safety and performance.

Please read this Owner's Handbook before riding in order to become thoroughly familiar with the correct operation of your motorcycle's controls, its features, capabilities and limitations.

This handbook includes safe riding tips, but does not contain all the techniques and skills necessary to ride a motorcycle safely.

Triumph strongly recommends that all riders undertake the necessary training to ensure safe operation of this motorcycle.

This handbook is available from your local dealer in:

- English
- US English
- French
- German
- Italian
- Dutch
- Spanish
- Portuguese
- Swedish
- Japanese
- Thai.

Talk to Triumph

Our relationship with you does not end with the purchase of your Triumph. Your feedback on the buying and ownership experience is very important in helping us develop our products and services for you.

Please help us by ensuring your authorised Triumph dealership has your email address and registers this with us. You will then receive an online customer satisfaction survey invitation to your email address where you can give us this feedback.

Your Triumph Team.

This page intentionally left blank

Safety First

The Motorcycle

All Models Except Street Scrambler

Warning

This motorcycle is designed for on-road use only. It is not suitable for off-road use.

Off-road operation could lead to loss of control of the motorcycle resulting in an accident causing injury or loss of life.

Street Scrambler Only

Warning

This motorcycle is designed for on-road and light off-road use. Light off-road use includes use on unpaved, dirt or gravel roads, but does not include riding on any motocross course, any off-road competition (such as motocross or enduro riding), or riding off-road with a passenger.

Light off-road use does not include jumping the motorcycle or riding over obstacles. Do not attempt to jump over any bumps or obstacles. Do not attempt to ride over any obstacles.

Extreme off-road use could lead to loss of motorcycle control and an accident.

Warning

This motorcycle is not designed to tow a trailer or be fitted with a sidecar. Fitting a sidecar and/or a trailer may result in loss of control and an accident.

Warning

This motorcycle is designed for use as a two-wheeled vehicle capable of carrying a rider on his/her own, or a rider and one passenger (subject to a passenger seat and footrests being fitted).

The total weight of the rider, and any passenger, accessories and luggage must not exceed the maximum load limit of 210 kg (463 lb).

Safety First

Fuel and Exhaust Fumes

Warning

PETROL IS HIGHLY FLAMMABLE:

Always turn off the engine when refuelling.

Do not refuel or open the fuel filler cap while smoking or in the vicinity of any open (naked) flame.

Take care not to spill any petrol on the engine, exhaust pipes or silencers when refuelling.

If petrol is swallowed, inhaled or allowed to get into the eyes, seek immediate medical attention.

Spillage on the skin should be immediately washed off with soap and water and clothing contaminated with petrol should immediately be removed.

Burns and other serious skin conditions may result from contact with petrol.

Warning

Never start the engine or run the engine in a confined area.

Exhaust fumes are poisonous and can cause loss of consciousness and death within a short period of time.

Always operate the motorcycle in the open air or in an area with adequate ventilation.

Helmet and Clothing



Warning

When riding the motorcycle, both rider and passenger (on models where carrying a passenger is permitted) must always wear appropriate clothing including a motorcycle helmet, eye protection, gloves, boots, trousers (close fitting around the knee and ankle) and a brightly coloured jacket.

During off-road use (on models suitable for off-road use), the rider must always wear appropriate clothing including trousers and boots.

Brightly coloured clothing will considerably increase a rider's (or passenger's) visibility to other operators of road vehicles.

Although full protection is not possible, wearing correct protective clothing can reduce the risk of injury when riding.

Warning

A helmet is one of the most important pieces of riding gear as it offers protection against head injuries. You and your passenger's helmet should be carefully chosen and should fit you or your passenger's head comfortably and securely. A brightly coloured helmet will increase a rider's (or passenger's) visibility to other operators of road vehicles.

An open face helmet offers some protection in an accident though a full face helmet will offer more.

Always wear a visor or approved goggles to help vision and to protect your eyes.

Parking

Warning

Always switch off the engine and remove the ignition key before leaving the motorcycle unattended. By removing the key, the risk of use of the motorcycle by unauthorised or untrained persons is reduced.

When parking the motorcycle, always remember the following:

- Engage first gear to help prevent the motorcycle from rolling off the stand.
- The engine and exhaust system will be hot after riding. DO NOT park where pedestrians, animals and/or children are likely to touch the motorcycle.
- Do not park on soft ground or on a steeply inclined surface. Parking under these conditions may cause the motorcycle to fall over.

For further details, please refer to the 'How to Ride the Motorcycle' section of this Owner's Handbook.

Safety First

Parts and Accessories

Warning

Owners should be aware that the only approved parts, accessories and conversions for any Triumph motorcycle are those which carry official Triumph approval and are fitted to the motorcycle by an authorised dealer.

In particular, it is extremely hazardous to fit or replace parts or accessories whose fitting requires the dismantling of, or addition to, either the electrical or fuel systems and any such modification could cause a safety hazard.

The fitting of any non-approved parts, accessories or conversions may adversely affect the handling, stability or other aspect of the motorcycle operation that may result in an accident causing injury or death.

Triumph does not accept any liability whatsoever for defects caused by the fitting of non-approved parts, accessories or conversions or the fitting of any approved parts, accessories or conversions by non-approved personnel.

Maintenance/Equipment

Warning

Consult your authorised Triumph dealer whenever there is doubt as to the correct or safe operation of this Triumph motorcycle.

Remember that continued operation of an incorrectly performing motorcycle may aggravate a fault and may also compromise safety.

Warning

Make sure all equipment that is required by law is installed and functioning correctly.

The removal or alteration of the motorcycle's lights, silencers, emission or noise control systems can violate the law.

Incorrect or improper modification may adversely affect the handling, stability or other aspect of the motorcycle operation, which may result in an accident causing injury or death.

Warning

If the motorcycle is involved in an accident, collision or fall, it must be taken to an authorised Triumph dealer for inspection and repair.

Any accident can cause damage to the motorcycle that, if not correctly repaired, may cause a second accident that may result in injury or death.

Riding

Warning

Never ride the motorcycle when fatigued or under the influence of alcohol or other drugs.

Riding when under the influence of alcohol or other drugs is illegal.

Riding when fatigued or under the influence of alcohol or other drugs reduces the rider's ability to maintain control of the motorcycle and may lead to loss of control and an accident.

Warning

All riders must be licenced to operate the motorcycle.

Operation of the motorcycle without a licence is illegal and could lead to prosecution.

Operation of the motorcycle without formal training in the correct riding techniques that are necessary to become licenced is dangerous and may lead to loss of motorcycle control and an accident.

Warning

Always ride defensively and wear the protective equipment mentioned elsewhere in this foreword.

Remember, in an accident, a motorcycle does not give the same impact protection as a car.

Warning

This Triumph motorcycle should be operated within the legal speed limits for the particular road travelled.

Operating a motorcycle at high speeds can be potentially dangerous since the time available to react to given traffic situations is greatly reduced as road speed increases.

Always reduce speed in potentially hazardous driving conditions such as bad weather or heavy traffic.

Warning

Continually observe and react to changes in road surface, traffic and wind conditions. All two-wheeled vehicles are subject to external forces which may cause an accident. These forces include but are not limited to:

- Wind draft from passing vehicles
- Potholes, uneven or damaged road surfaces
- Bad weather
- Rider error.

Always operate the motorcycle at moderate speed and away from heavy traffic until you have become thoroughly familiar with its handling and operating characteristics. Never exceed the legal speed limit.

Safety First

Handlebars and Footrests

Warning

The rider must maintain control of the vehicle by keeping hands on the handlebars at all times.

The handling and stability of a motorcycle will be adversely affected if the rider removes their hands from the handlebars, resulting in loss of motorcycle control and an accident.

Warning

The rider and passenger (if applicable) must always use the footrests provided, during operation of the vehicle.

By using the footrests, both rider and passenger will reduce the risk of inadvertent contact with any motorcycle components and will also reduce the risk of injury from entrapment of clothing.

Warning

Use of a motorcycle with bank angle indicators worn beyond the maximum limit will allow the motorcycle to be banked to an unsafe angle. Therefore, always replace the bank angle indicator pegs before they are worn to their maximum limit. Banking to an unsafe angle may cause instability, loss of motorcycle control and an accident.

Details of the bank angle wear limits can be found in the Maintenance and Adjustment section on page 132.

Warning

The bank angle indicators must not be used as a guide to how far the motorcycle may be safely banked.

This depends on many various conditions including, but not limited to, road surface, tyre condition and weather. Banking to an unsafe angle may cause instability, loss of motorcycle control and an accident.

Warning

When banking and the bank angle indicator, attached to the rider's footrest, makes contact with the ground, the motorcycle is nearing its bank angle limit. A further increase of the banking angle is unsafe.

Banking to an unsafe angle may cause instability, loss of motorcycle control and an accident.

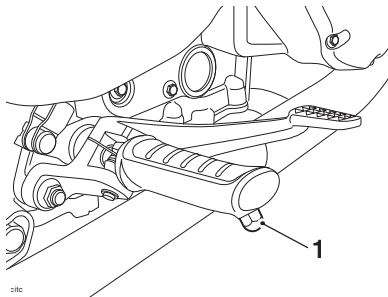

1. Bank angle indicator

This page intentionally left blank

Warning Label Locations

Warning Label Locations

The labels detailed on this and the following pages draw your attention to important safety information in this handbook. Before riding, make sure that all riders have understood and complied with all the information to which these labels relate.

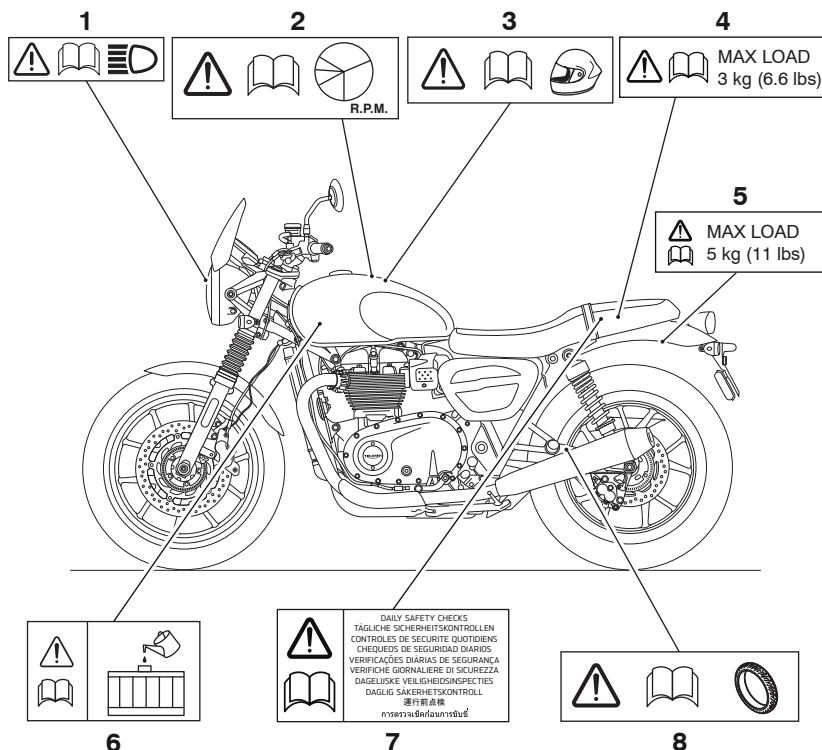

1. Headlight (page 143)
2. Running-In (page 76)
3. Helmet (page 8)
4. Luggage Rack (if fitted) (page 74)
5. Panniers (if fitted) (page 93)
6. Coolant (page 107)
7. Daily Safety Checks (page 77)
8. Tyres (page 132)

Warning Label Locations

Warning Label Locations (continued)

⚠ Caution

All warning labels and decals, with the exception of the Running-in label, are fitted to the motorcycle using a strong adhesive. In some cases, labels are installed prior to an application of paint lacquer. Therefore, any attempt to remove the warning labels will cause damage to the paintwork or bodywork.

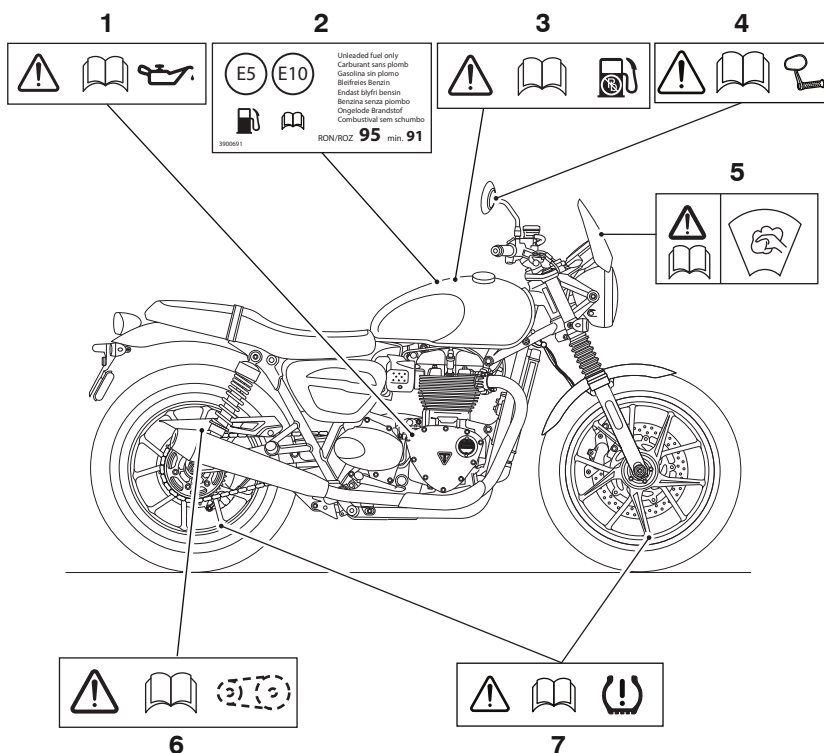

1. Engine Oil (page 103)
2. E5 and E10 Fuel (if fitted) (page 64)
3. Unleaded Fuel (page 64)
4. Mirrors (page 122)
5. Windscreen (if fitted) (page 155)
6. Drive Chain (page 113)
7. Tyre Pressure Monitoring System (if fitted) (page 52)

Parts Identification

Parts Identification

Bonneville T100, Bonneville T120, Bonneville T120 Ace and Bonneville T120 Diamond (Bonneville T120 shown)

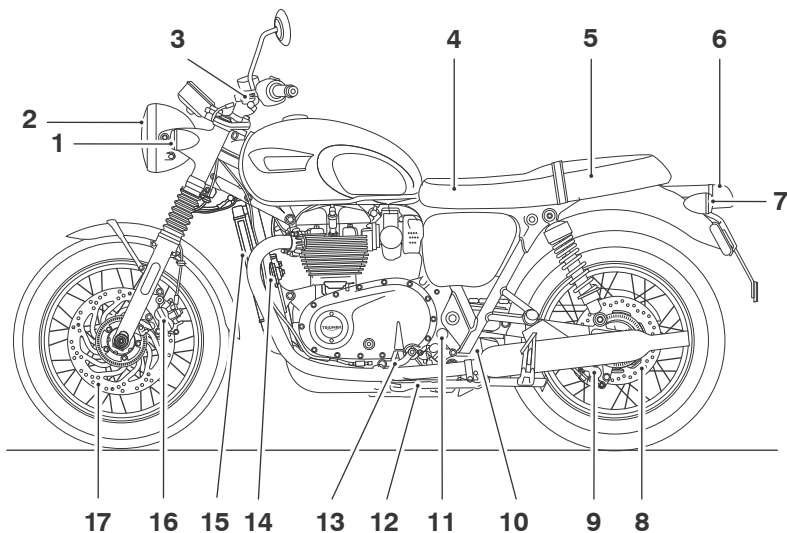

- | | |
|---|--------------------------------|
| 1. Front direction indicator | 9. Rear brake caliper |
| 2. Headlight | 10. Coolant expansion tank |
| 3. Clutch lever | 11. Coolant expansion tank cap |
| 4. Battery (under seat) | 12. Side stand |
| 5. Owner's Handbook (under seat) or supplied separately | 13. Gear change pedal |
| 6. Brake/rear light | 14. Horn |
| 7. Rear direction indicator | 15. Radiator |
| 8. Rear brake disc | 16. Front brake caliper |
| | 17. Front brake disc |

Parts Identification - Continued

Bonneville T100, Bonneville T120, Bonneville T120 Ace and Bonneville T120 Diamond (Bonneville T120 shown)

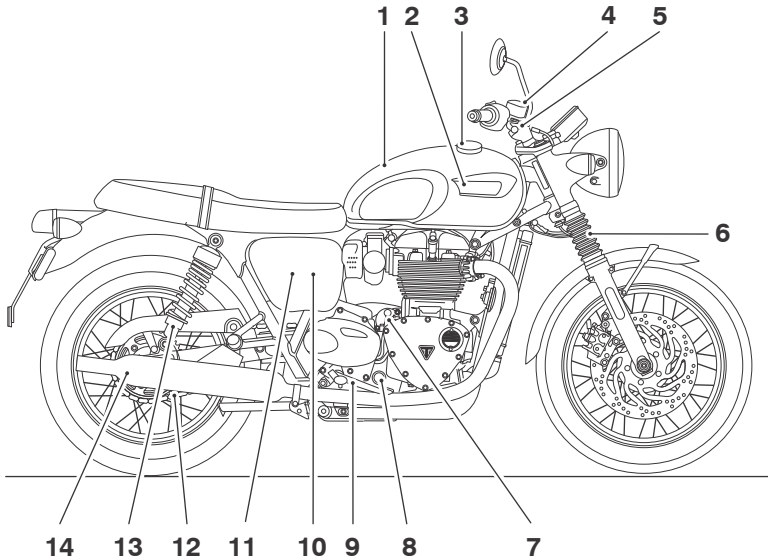

- | | |
|---|--|
| 1. Fuel tank | 9. Rear brake pedal |
| 2. Coolant pressure cap (under fuel tank) | 10. Rear brake fluid reservoir (behind side panel) |
| 3. Fuel filler cap | 11. Adjustment tool (behind side panel) |
| 4. Front brake fluid reservoir | 12. Drive chain |
| 5. Front brake lever | 13. Rear suspension unit |
| 6. Front fork | 14. Silencer |
| 7. Oil filler plug | |
| 8. Oil level sight glass | |

Parts Identification

Parts Identification

Street Scrambler

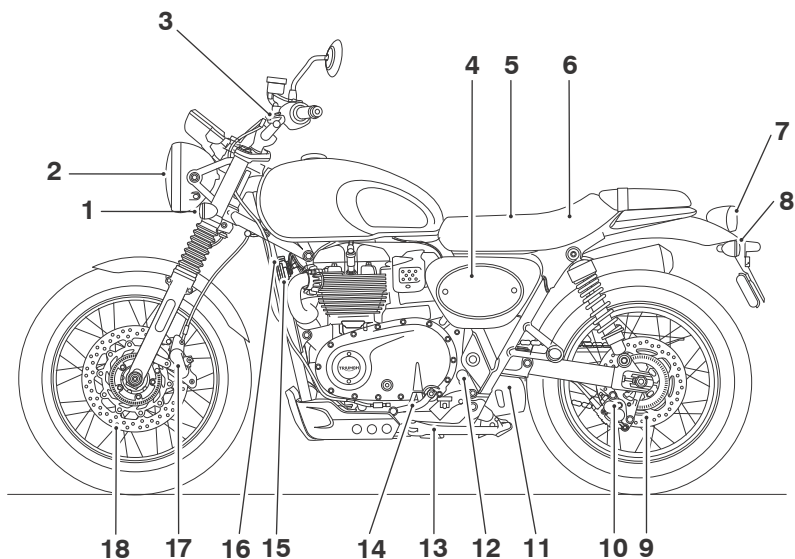

- | | |
|--|--------------------------------|
| 1. Front direction indicator | 10. Rear brake caliper |
| 2. Headlight | 11. Coolant expansion tank |
| 3. Clutch lever | 12. Coolant expansion tank cap |
| 4. Adjustment tool (behind side panel) | 13. Side stand |
| 5. Battery (under seat) | 14. Gear change pedal |
| 6. Owner's Handbook (under seat) | 15. Horn |
| 7. Brake/rear light | 16. Radiator |
| 8. Rear direction indicator | 17. Front brake caliper |
| 9. Rear brake disc | 18. Front brake disc |

Parts Identification - Continued

Street Scrambler

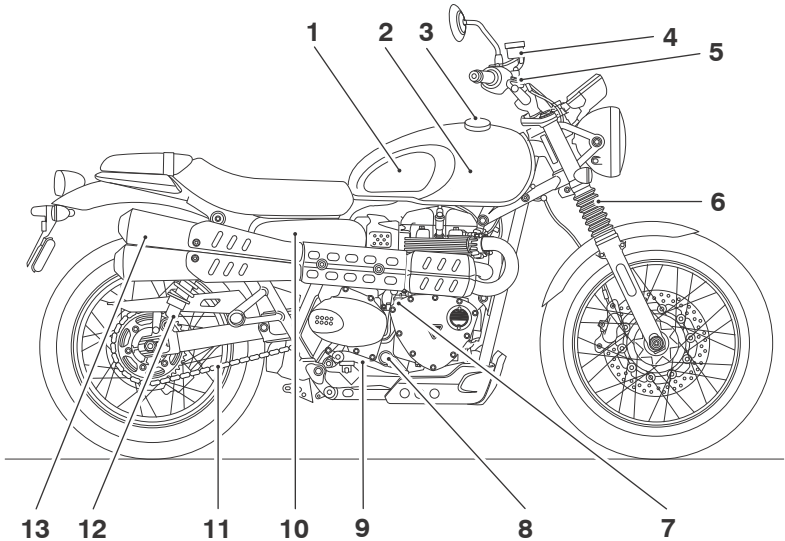

- | | |
|---|--|
| 1. Fuel tank | 8. Oil level sight glass |
| 2. Coolant pressure cap (under fuel tank) | 9. Rear brake pedal |
| 3. Fuel filler cap | 10. Rear brake fluid reservoir (behind side panel) |
| 4. Front brake fluid reservoir | 11. Drive chain |
| 5. Front brake lever | 12. Rear suspension unit |
| 6. Front fork | 13. Silencer |
| 7. Oil filler plug | |

Parts Identification

Parts Identification

Speed Twin

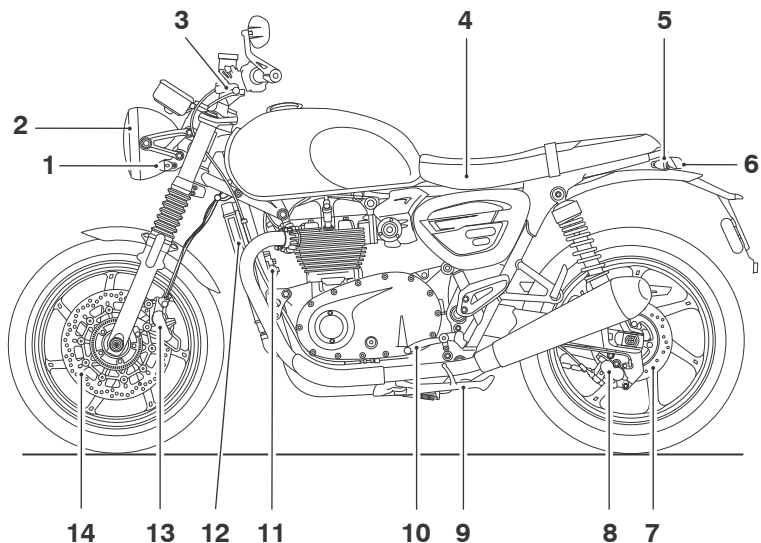

1. Front direction indicator
2. Headlight
3. Clutch lever
4. Battery (under seat)
5. Rear direction indicator
6. Brake/rear light
7. Rear brake disc

8. Rear brake caliper
9. Side stand
10. Gear change pedal
11. Horn
12. Radiator
13. Front brake caliper
14. Front brake disc

Parts Identification - Continued

Speed Twin

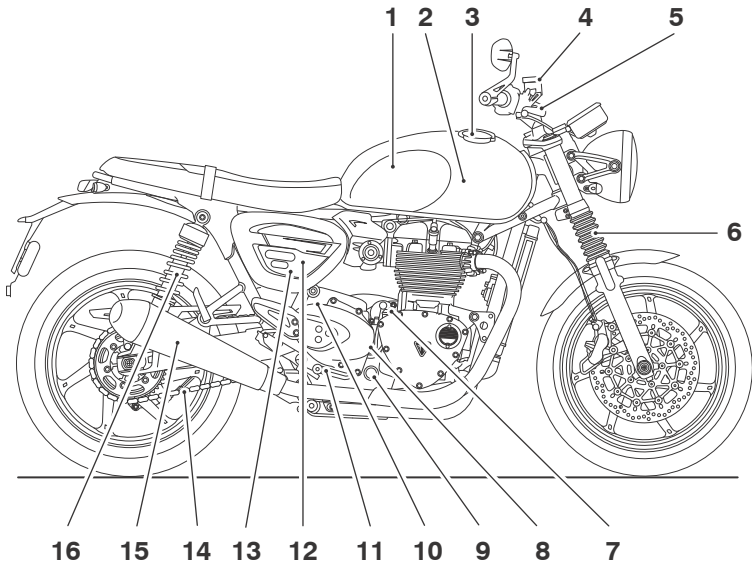

- | | |
|---|--|
| 1. Fuel tank | 10. Coolant expansion tank cap |
| 2. Coolant pressure cap (under fuel tank) | 11. Rear brake pedal |
| 3. Fuel filler cap | 12. Rear brake fluid reservoir (behind side panel) |
| 4. Front brake fluid reservoir | 13. Adjustment tool (behind side panel) |
| 5. Front brake lever | 14. Drive chain |
| 6. Front fork | 15. Silencer |
| 7. Oil filler plug | 16. Rear suspension unit |
| 8. Coolant expansion tank | |
| 9. Oil level sight glass | |

Parts Identification

Parts Identification

Street Twin

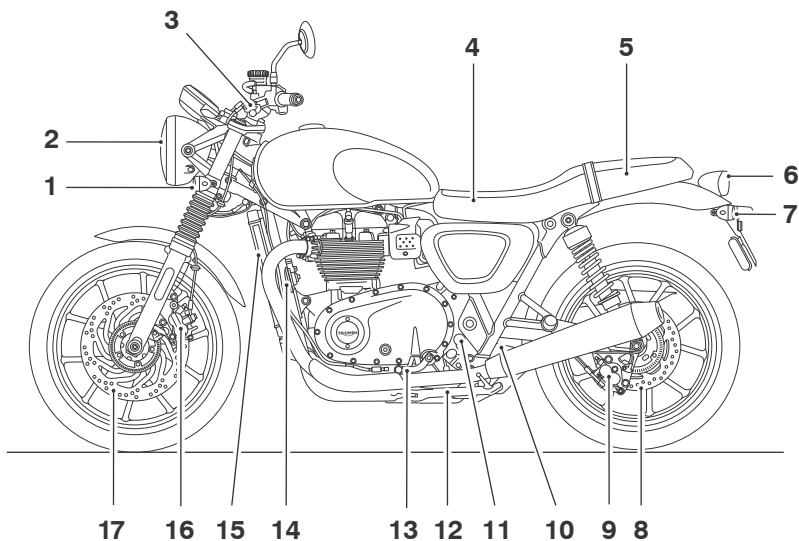

1. Front direction indicator

2. Headlight

3. Clutch lever

4. Battery (under seat)

5. Owner's Handbook (under seat)

6. Brake/rear light

7. Rear direction indicator

8. Rear brake disc

9. Rear brake caliper

10. Coolant expansion tank

11. Coolant expansion tank cap

12. Side stand

13. Gear change pedal

14. Horn

15. Radiator

16. Front brake caliper

17. Front brake disc

Parts Identification - Continued

Street Twin

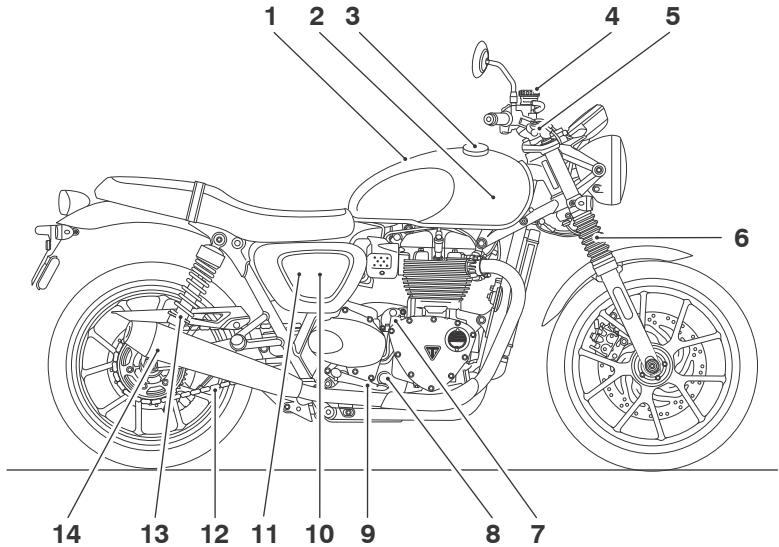

- | | |
|---|--|
| 1. Fuel tank | 9. Rear brake pedal |
| 2. Coolant pressure cap (under fuel tank) | 10. Rear brake fluid reservoir (behind side panel) |
| 3. Fuel filler cap | 11. Adjustment tool (behind side panel) |
| 4. Front brake fluid reservoir | 12. Drive chain |
| 5. Front brake lever | 13. Rear suspension unit |
| 6. Front fork | 14. Silencer |
| 7. Oil filler plug | |
| 8. Oil level sight glass | |

Parts Identification

Parts Identification

Thruxton and Thruxton R (Thruxton shown)

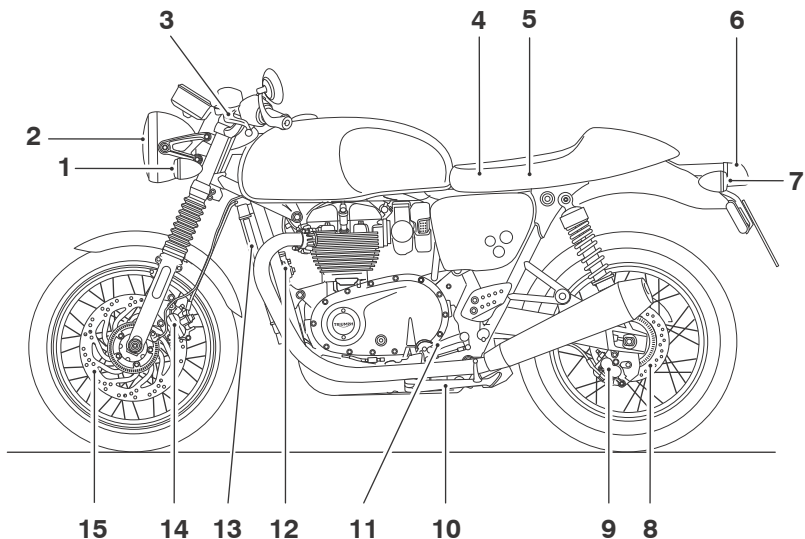

- | | |
|----------------------------------|-------------------------|
| 1. Front direction indicator | 9. Rear brake caliper |
| 2. Headlight | 10. Side stand |
| 3. Clutch lever | 11. Gear change pedal |
| 4. Battery (under seat) | 12. Horn |
| 5. Owner's Handbook (under seat) | 13. Radiator |
| 6. Brake/rear light | 14. Front brake caliper |
| 7. Rear direction indicator | 15. Front brake disc |
| 8. Rear brake disc | |

Parts Identification - Continued

Thruxton and Thruxton R (Thruxton shown)

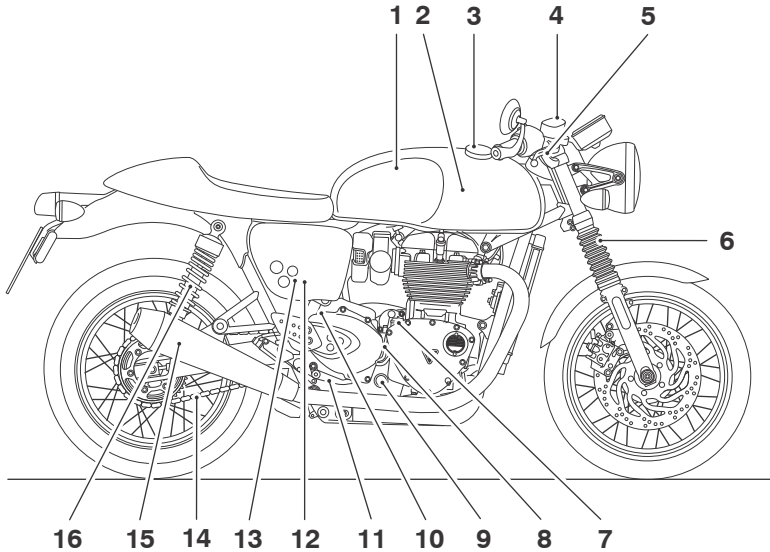

- | | |
|---|--|
| 1. Fuel tank | 10. Coolant expansion tank cap |
| 2. Coolant pressure cap (under fuel tank) | 11. Rear brake pedal |
| 3. Fuel filler cap | 12. Rear brake fluid reservoir (behind side panel) |
| 4. Front brake fluid reservoir | 13. Adjustment tool (behind side panel) |
| 5. Front brake lever | 14. Drive chain |
| 6. Front fork | 15. Silencer |
| 7. Oil filler plug | 16. Rear suspension unit |
| 8. Coolant expansion tank | |
| 9. Oil level sight glass | |

Parts Identification

Rider View Parts Identification

Bonneville T100, Bonneville T120, Bonneville T120 Ace, Bonneville T120 Diamond, Speed Twin, Thruxton and Thruxton R (Thruxton shown)

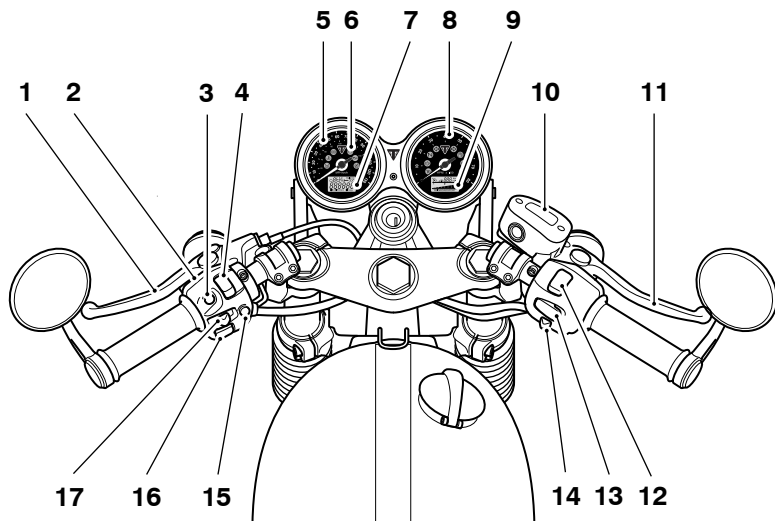

- | | |
|--|---|
| 1. Clutch lever | 12. Engine start/stop switch |
| 2. Headlight dip switch | 13. MODE button (Bonneville T120, Bonneville T120 Ace, Bonneville T120 Diamond and Thruxton only) |
| 3. SCROLL button | 14. Hazard button |
| 4. Daytime Running Lights (DRL) switch (if fitted) | 15. MODE button (Speed Twin and Thruxton R only) |
| 5. Speedometer | 16. Horn button |
| 6. Warning lights | 17. Indicator switch |
| 7. Trip computer/Odometer/Information display screen | |
| 8. Tachometer | |
| 9. Information display screen | |
| 10. Front brake fluid reservoir | |
| 11. Front brake lever | |

Rider View Parts Identification

Street Scrambler and Street Twin (Street Twin shown)

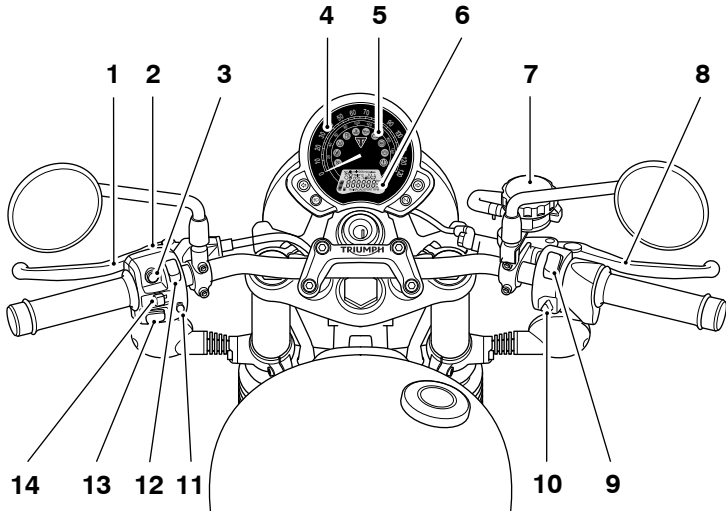

- | | |
|--|---|
| 1. Clutch lever | 9. Engine start/stop switch |
| 2. Headlight dip switch | 10. Hazard button |
| 3. SCROLL button | 11. MODE button |
| 4. Speedometer | 12. Daytime Running Lights (DRL) switch (if fitted) |
| 5. Warning lights | 13. Horn button |
| 6. Odometer/Information display screen | 14. Direction indicator switch |
| 7. Front brake fluid reservoir | |
| 8. Front brake lever | |

Parts Identification

This page intentionally left blank

Serial Numbers

Vehicle Identification Number (VIN)

The vehicle identification number is stamped into the steering head area of the frame. It is also shown on a label located next to it.

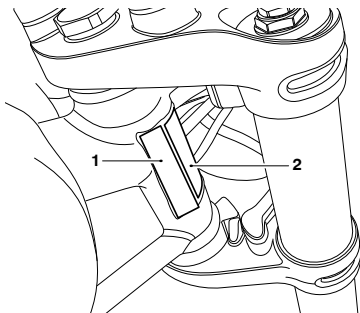

1. VIN stamp
2. VIN label

Record the vehicle identification number in the space provided below.

Engine Serial Number

The engine serial number is stamped on the upper engine crankcase, towards the rear, and is visible from the right hand side, behind the starter motor.

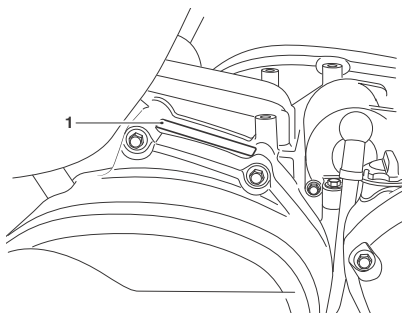

1. Engine serial number

Record the engine serial number in the space provided below.

This page intentionally left blank

General Information

Table of Contents

Instrument Panel Layout	34
Warning Lights	36
Engine Management System Malfunction Indicator Light (MIL)	36
Low Oil Pressure Warning Light	36
High Coolant Temperature Warning Light	36
Immobiliser/Alarm Indicator Light	37
Anti-lock Braking System (ABS) Warning Light	37
Traction Control (TC) Indicator Light	38
Traction Control (TC) Disabled Warning Light	38
Direction Indicators	38
High Beam	38
Daytime Running Lights (DRL) (if fitted)	39
Neutral	39
Low Fuel Indicator Light	39
Tyre Pressure Warning Light	39
General Warning Symbol	40
Instruments	41
Speedometer and Odometer	41
Tachometer	41
Gear Position Display	41
Fuel Gauge	42
Range to Empty	42
Average Fuel Consumption	43
Trip Meter	44
Clock	45
Riding Modes	46
Selecting a Riding Mode - with the Motorcycle Stationary	47
Selecting a Riding Mode - when Riding the Motorcycle	48
Traction Control (TC)	49
Traction Control Settings	50
To Disable the Traction Control	50
ABS Disable and Enable - Thruxton and Thruxton R Models Only	51

General Information

Tyre Pressure Monitoring System (TPMS) (if fitted)	52
Tyre Pressure Sensor Serial Number	52
System Display	53
Sensor Batteries	53
Tyre Pressures	54
Replacement Tyres	54
Ignition Switch/Steering Lock	54
Engine Immobiliser	55
Ignition Key	55
Right Handlebar Switches	56
STOP Position	57
RUN Position	57
START Position	57
MODE Button (if fitted)	57
Hazard Warning Lights	57
Left Handlebar Switches	58
SCROLL Button	58
Horn Button	58
Direction Indicator Switch	59
MODE Button (if fitted)	59
Daytime Running Lights (DRL) Switch (if fitted)	59
High Beam Light	59
Heated Grips (if fitted)	60
Throttle Control	61
Clutch Lever Adjusters	62
Brake Lever Adjusters	63
Fuel	64
Fuel Tank Cap	65
Filling the Fuel Tank	66
Side Stand	67
Centre Stand (if fitted)	68
Side Panels	68
Tool Kit and Owner's Handbook	70
Helmet Hook (if fitted)	71

General Information

Seats.....	71
Seat Care.....	71
Seat Lock.....	72
Seat Removal and Installation.....	72
Street Scrambler Seat Removal.....	73
Street Scrambler Seat Installation.....	73
Luggage Rack.....	74
Universal Serial Bus (USB) Socket.....	75
Running-In.....	76
Daily Safety Checks.....	77

General Information

Instrument Panel Layout

Street Scrambler and Street Twin (Street Twin shown)

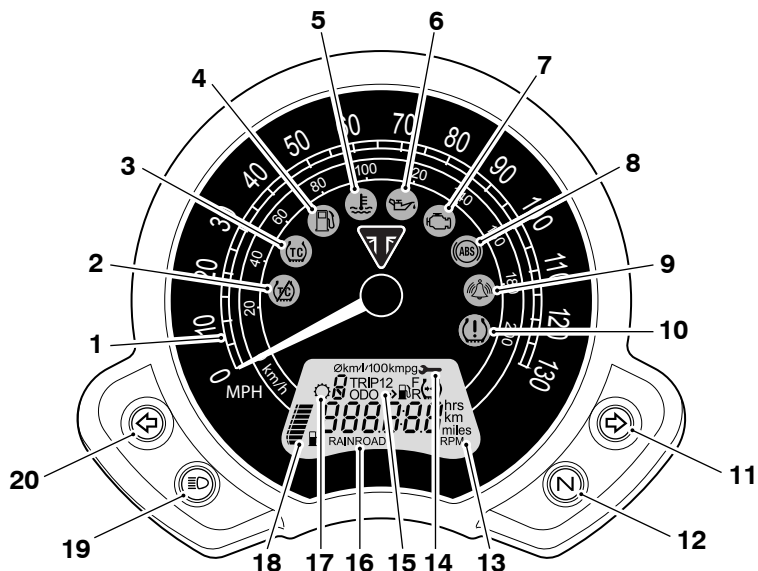

1. Speedometer
2. Traction Control (TC) disabled warning light
3. Traction Control (TC) indicator light
4. Low fuel level indicator light
5. High coolant temperature warning light
6. Low oil pressure warning light
7. Engine management Malfunction Indicator Light (MIL)
8. Anti-lock Brake System (ABS) warning light
9. Immobiliser/Alarm status indicator light (alarm is an accessory kit)
10. Tyre pressure warning light (if Tyre Pressure Monitoring System (TPMS) is fitted)
11. Right hand direction indicator light
12. Neutral indicator light
13. Tachometer
14. Service interval indicator
15. Odometer/Trip meter/Clock
16. Rider mode display
17. Gear position indicator
18. Fuel gauge
19. High beam indicator light
20. Left hand direction indicator light

Instrument Panel Layout

Bonneville T100, Bonneville T120, Bonneville T120 Ace,
Bonneville T120 Diamond, Speed Twin, Thruxton and Thruxton R

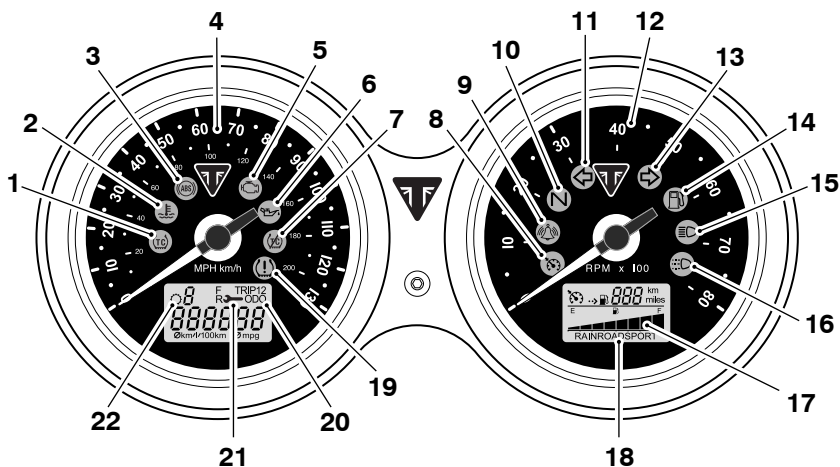

1. Traction Control (TC) indicator light
2. High coolant temperature warning light
3. Anti-lock Brake System (ABS) warning light
4. Speedometer
5. Engine management Malfunction Indicator Light (MIL)
6. Low oil pressure warning light
7. Traction Control (TC) disabled warning light
8. Cruise control indicator light (if fitted)
9. Immobiliser/Alarm indicator light (alarm is an accessory kit)
10. Neutral indicator light
11. Left hand direction indicator light
12. Tachometer
13. Right hand direction indicator light
14. Low fuel level indicator light
15. High beam indicator light
16. Daytime Running Lights (DRL) indicator light (if fitted)
17. Rider mode display (if fitted)
18. Range to empty display
19. Tyre pressure warning light (if Tyre Pressure Monitoring System (TPMS) is fitted)
20. Odometer/Trip computer
21. Service interval indicator
22. Gear position indicator

General Information

Warning Lights

Engine Management System Malfunction Indicator Light (MIL)



The Malfunction Indicator Light (MIL) for the engine management system illuminates when the ignition

is switched ON (to indicate that it is working) but should not become illuminated when the engine is running.

If the engine is running and there is a fault with the engine management system the MIL will be illuminated and the general warning symbol will flash. In such circumstances, the engine management system may switch to 'limp-home' mode so that the journey may be completed, if the fault is not so severe that the engine will not run.

Warning

Reduce speed and do not continue to ride for longer than is necessary with the MIL illuminated. The fault may adversely affect engine performance, exhaust emissions and fuel consumption.

Reduced engine performance could cause a dangerous riding condition, leading to loss of control and an accident.

Contact an authorised Triumph dealer as soon as possible to have the fault checked and rectified.

Note

If the MIL flashes when the ignition is switched ON contact an authorised Triumph dealer as soon as possible to have the situation rectified. In these circumstances the engine will not start.

Low Oil Pressure Warning Light



With the engine running, if the engine oil pressure becomes dangerously low, the low oil pressure warning light will illuminate.

Caution

Stop the engine immediately if the low oil pressure warning light illuminates. Do not restart the engine until the fault has been rectified.

Severe engine damage will result from running the engine when the low oil pressure warning light is illuminated.

Note

The low oil pressure warning light will illuminate if the ignition is switched ON without running the engine.

High Coolant Temperature Warning Light



With the engine running, if the engine coolant temperature becomes dangerously high, the high coolant temperature warning light will illuminate.

Caution

Stop the engine immediately if the high coolant temperature warning light illuminates. Do not restart the engine until the fault has been rectified.

Severe engine damage will result from running the engine when the high coolant temperature warning light is illuminated.

Immobiliser/Alarm Indicator Light



This Triumph motorcycle is fitted with an engine immobiliser which is activated when the ignition switch is turned to the OFF position.

Without Alarm Fitted

When the ignition switch is turned to the OFF position, the immobiliser/alarm light will flash on and off for 24 hours to show that the engine immobiliser is on. When the ignition switch is turned to the ON position the immobiliser and the indicator light will be off.

If the indicator light remains on it indicates that the immobiliser has a malfunction that requires investigation. Contact an authorised Triumph dealer as soon as possible to have the fault checked and rectified.

With Alarm Fitted

The immobiliser/alarm light will only illuminate when the conditions described in the genuine Triumph accessory alarm instructions are met.

Anti-lock Braking System (ABS) Warning Light



When the ignition switch is turned to the ON position, it is normal that the ABS warning light will flash on and off. The light will continue to flash after engine start-up until the motorcycle first reaches a speed exceeding 6 mph (10 km/h) when it will go off.

Note

Traction control will not function if there is a malfunction with the ABS. The warning lights for the ABS, traction control and the MIL will be illuminated.

The warning light will not illuminate again until the engine is restarted unless there is a fault, or the ABS is disabled by the rider.

If the ABS is disabled by the rider the warning light will illuminate until the ABS is enabled again.

If there is a fault with the ABS system the warning light will be illuminated and the general warning symbol will flash.

Warning

If the ABS is not functioning, the brake system will continue to function as a non-ABS braking system.

Do not continue to ride for longer than is necessary with the indicator light illuminated.

Contact an authorised Triumph dealer as soon as possible to have the fault checked and rectified. In this situation braking too hard will cause the wheels to lock resulting in loss of motorcycle control and an accident.

General Information

Traction Control (TC) Indicator Light



The TC indicator light is used to indicate that the traction control system is active and is working to limit rear wheel slip during periods of hard acceleration or under wet or slippery road conditions.

Warning

If the traction control is not functioning, care must be taken when accelerating and cornering on wet/slippery road surfaces to avoid rear wheel spin. Do not continue to ride for longer than is necessary with the Engine Management System Malfunction Indicator Light (MIL) and traction control warning lights illuminated. Contact an authorised Triumph dealer as soon as possible to have the fault checked.

Hard acceleration and cornering in this situation may cause the rear wheel to spin resulting in loss of motorcycle control and an accident.

TC Indicator Light Operation:

TC Switched On:

- Under normal riding conditions the indicator light will remain off.
- The indicator light will flash rapidly when the traction control system is working to limit rear wheel slip during periods of hard acceleration or under wet or slippery road conditions.

TC Switched Off:

The indicator light will not illuminate. Instead the TC disabled warning light will be illuminated (see page 38).

Note

Traction control will not function if there is a malfunction with the ABS system. The warning lights for the ABS, traction control and the MIL will be illuminated.

Traction Control (TC) Disabled Warning Light



The TC disabled warning light should not illuminate unless traction control is switched off or there is a malfunction.

If the warning light becomes illuminated at any other time while riding, it indicates that the traction control system has a malfunction that requires investigation.

Direction Indicators



When the direction indicator switch is turned to the left or right, the direction indicator warning light will flash on and off at the same speed as the direction indicators.

High Beam



When the ignition is switched ON and the high beam is selected, the high beam warning light will illuminate.

Daytime Running Lights (DRL) (if fitted)



When the ignition is switched ON and the daytime running lights switch is set to DAYTIME RUNNING LIGHTS, the daytime running lights warning light will illuminate.

The daytime running lights and low beam headlights are operated manually using a switch on the left hand switch housing, see page 59.



Warning

Do not ride for longer than necessary in poor ambient light conditions with the Daytime Running Lights (DRL) in use.

Riding with the Daytime Running Lights when dark, in tunnels or where poor ambient light is apparent may reduce the riders vision or dazzle other road users.

Dazzling other road users or reduced vision in low ambient light levels may result in loss of motorcycle control and an accident.

Note

During daylight hours the Daytime Running Lights improve the motorcycles visibility to other road users.

Low beam headlights must be used in any other conditions unless the road conditions allow for high beam headlights to be used.

Neutral



The neutral warning light indicates when the transmission is in neutral (no gear selected). The warning light will illuminate when the transmission is in neutral with the ignition switch in the ON position.

Low Fuel Indicator Light



The low fuel indicator light will illuminate when there are approximately 3.0 litres of fuel remaining in the tank.

Tyre Pressure Warning Light

Note

Tyre Pressure Monitoring System (TPMS) is an accessory option only available on models fitted with cast alloy wheels.



The tyre pressure warning light works in conjunction with the Tyre Pressure Monitoring System (TPMS) (see page 52).

The warning light will only illuminate when the front or rear tyre pressure is below the recommended pressure. It will not illuminate if the tyre is over inflated.

General Information

When the warning light is illuminated, the TPMS symbol indicating which is the deflated tyre and its pressure will automatically be visible in the display screen.

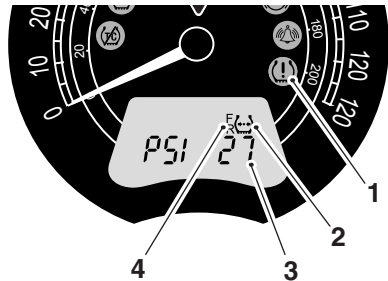

1. Tyre pressure warning light
2. TPMS symbol
3. Tyre pressure
4. Front and rear tyre indicators

The tyre pressure at which the warning light illuminates is temperature compensated to 20°C but the numeric pressure display associated with it is not. Even if the numeric display seems at or close to the standard tyre pressure when the warning light is on, a low tyre pressure is indicated and a puncture is the most likely cause.

Warning

Stop the motorcycle if the tyre pressure warning light illuminates.

Do not ride the motorcycle until the tyres have been checked and the tyre pressures are at their recommended pressure when cold.

General Warning Symbol

 The general warning symbol will flash if an ABS or engine management fault has occurred and the ABS and/or MIL warning lights are illuminated. Contact an authorised Triumph dealer as soon as possible to have the fault checked and rectified.

Instruments

Speedometer and Odometer

The speedometer indicates the road speed of the motorcycle.

The odometer shows the total distance that the motorcycle has travelled.

Tachometer

Caution

Never allow engine speed to enter the red zone as severe engine damage may result.

The tachometer shows the engine speed in revolutions per minute - rpm (r/min). At the end of the tachometer range there is the red zone.

Engine speeds in the red zone are above maximum recommended engine speed and are also above the range for best performance.

Gear Position Display

Street Scrambler and Street Twin Only

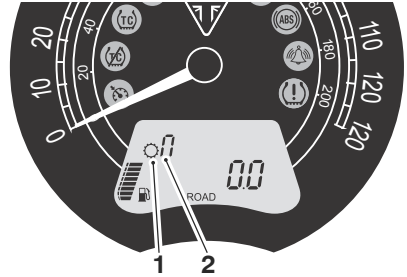

1. Gear position symbol
2. Gear position display (neutral position shown)

All Other Models

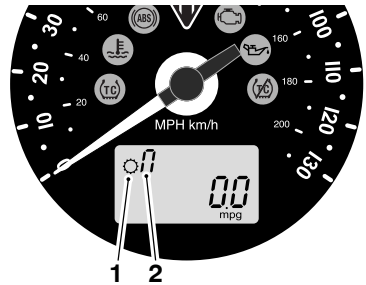

1. Gear position symbol
2. Gear position display (neutral position shown)

The gear position display indicates which gear (1-5 or 1-6) has been engaged. When the transmission is in neutral (no gear selected), the display screen will show **n**.

General Information

Fuel Gauge

Street Scrambler and Street Twin Only

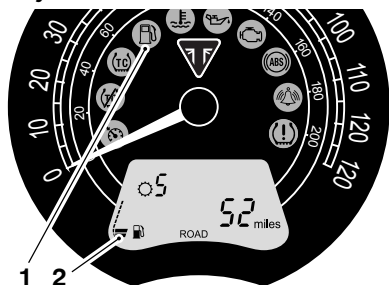

1. Low fuel indicator light
2. Fuel gauge

All Other Models

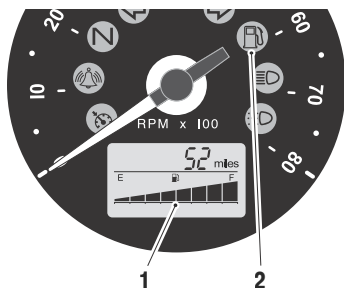

1. Fuel gauge
2. Low fuel indicator light

The fuel gauge indicates the amount of fuel in the tank. With the ignition switched on, the number of bars shown in the display indicates the level of fuel.

When the fuel tank is full all eight bars are displayed and when empty, no bars are displayed. Other gauge markings indicate intermediate fuel levels between full and empty.

When there are approximately 3.0 litres of fuel remaining in the tank, the low fuel warning light will illuminate.

Note

After refuelling, the fuel gauge and range to empty information will be updated only while riding the motorcycle. Depending on the riding style, updating could take up to five minutes.

Range to Empty

Street Scrambler and Street Twin Only

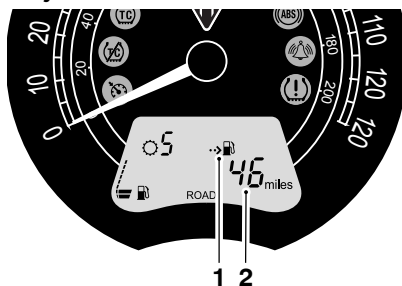

1. Range to empty indicator
2. Estimated distance remaining

All Other Models

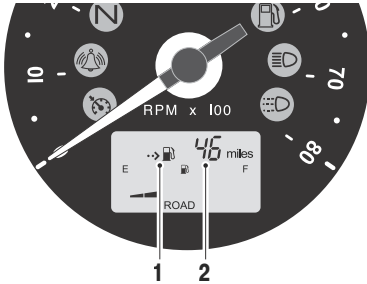

1. Range to empty indicator
2. Estimated distance remaining

This is an indication of the predicted distance that can be travelled on the remaining fuel in the tank.

Note

After refuelling, the fuel gauge and range to empty information will be updated only while riding the motorcycle. Depending on the riding style, updating could take up to five minutes.

Average Fuel Consumption

Street Scrambler and Street Twin Only

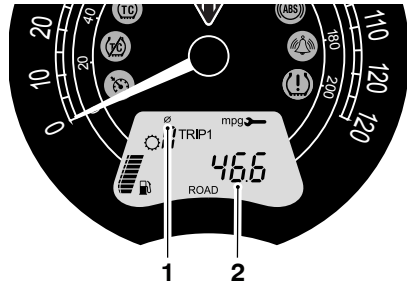

1. Average symbol
2. Average fuel consumption

All Other Models



1. Average symbol
2. Average fuel consumption

This is an indication of the average fuel consumption. After being reset the display will show dashes until 0.1 miles/km has been covered.

Note

After refuelling, the average consumption information will be updated only while riding the motorcycle. Depending on the riding style, updating could take up to five minutes.

General Information

Trip Meter

Warning

Do not attempt to switch between the odometer and trip meter display modes or reset the trip meter with the motorcycle in motion as this may lead to loss of motorcycle control and an accident.

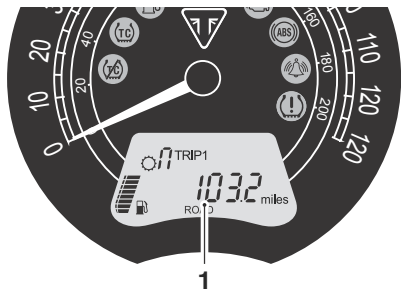

1. Trip meter display (Trip 1 selected)

There are two trip meters. Either trip meter shows the distance that the motorcycle has travelled since the meter on display was last reset to zero.

To switch between trip meters, press and release the SCROLL button, located on the left hand handlebar switch housing, until the desired trip meter is shown.

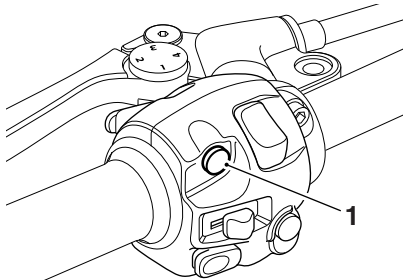

04b_1

1. SCROLL button

Note

Street Scrambler Only

The trip meters are not accessible when in OFF ROAD mode. The trip meter data continues to be collected when riding in OFF ROAD mode. The updated trip meter data is shown in the trip meters after switching the OFF ROAD mode off.

Trip Meter Reset

To reset either of the trip meters, select and display the trip meter to be zeroed. Then press and hold the SCROLL button for one second. After more than one second, the trip meter on display will reset to zero.

Clock

To access the clock, press and release the SCROLL button, located on the left hand handlebar switch housing, until the clock is shown.



1. Clock

- When the correct hour display is shown, press and hold the SCROLL button for one second. The hours display is set and the minutes display will begin to flash. The minutes display is adjusted in the same way as for the hour display.
- Once both hours and minutes are correctly set, press the SCROLL button for one second and the display will cease to flash.

Clock Adjustment

Warning

Do not attempt to adjust the clock with the motorcycle in motion as this may lead to loss of motorcycle control and an accident.

To reset the clock:

- Select the clock display.
- Press and hold the SCROLL button for one second, the clock's hour display will start to flash. Release the SCROLL button.

To reset the hour display:

- Make sure the hour display is still flashing then press and release the SCROLL button to change the setting. Each individual button press will change the setting by one digit.

General Information

Riding Modes

Note

Riding modes are available on all models except Bonneville T100.

The riding mode system allows the selection of riding modes with specific traction control and throttle response settings.

Riding modes are selected using the MODE button on either the left or right hand handlebar switch housing, depending on the model.

Press and release the MODE button to select one of the following riding modes.

Bonneville T120, Bonneville T120 Ace, Bonneville T120 Diamond and Street Twin	
Riding Mode	Description
ROAD	Standard throttle response. Optimal traction control setting for road use.
RAIN	Reduced throttle response when compared to the ROAD setting, for wet or slippery conditions. Optimal traction control setting for road use in rain conditions and allows minimal rear wheel slip.

Speed Twin, Thruxton and Thruxton R	
Riding Mode	Description
ROAD	Standard throttle response. Optimal traction control setting for road use.
RAIN	Reduced throttle response when compared to the ROAD setting, for wet or slippery conditions. Optimal traction control setting for road use in rain conditions and allows minimal rear wheel slip.
SPORT	Increased throttle response when compared to the ROAD setting. Optimal traction control setting for road use and allows minimal rear wheel slip.

Street Scrambler Only

Street Scrambler	
Riding Mode	Description
ROAD	Standard throttle response. Optimal traction control setting for road use.
RAIN	Reduced throttle response when compared to the ROAD setting, for wet or slippery conditions. Optimal traction control setting for road use in rain conditions and allows minimal rear wheel slip.
OFF ROAD	Optimal throttle response setting for off-road use. ABS is off. Traction control is off. Trip meters are not shown. Trip meter data continues to be collected when riding in this mode. OFF ROAD mode can only be selected when the motorcycle is stationary.

If OFF ROAD mode is selected, it is shown in the main display.

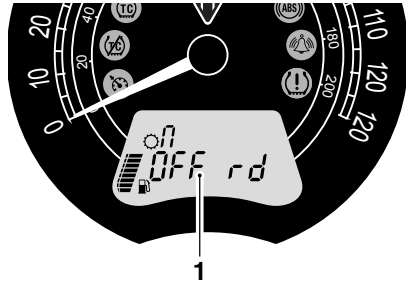

1. OFF ROAD mode display (Street Scrambler only)

When in OFF ROAD mode, a long press on the MODE button changes the riding mode to ROAD mode.

Selecting a Riding Mode - with the Motorcycle Stationary

Press and release the MODE button on either the left or right hand handlebar switch housing (model specific) until the required riding mode is flashing in the display.

The selected riding mode is automatically activated one second after the MODE button is pressed, if the following conditions are met:

With the Engine Off

- The ignition is switched ON.
- The engine stop switch is in the RUN position.

With the Engine Running

- The transmission is in neutral or the clutch is pulled in.

General Information

Selecting a Riding Mode – when Riding the Motorcycle

Warning

The selection of riding modes whilst the motorcycle is in motion requires the rider to allow the motorcycle to coast (motorcycle moving, engine running, throttle closed, clutch lever pulled in and no brakes applied) for a brief period of time.

Riding mode selection whilst the motorcycle is in motion should only be attempted:

- At low speed
- In traffic free areas
- On straight and level roads or surfaces
- In good road and weather conditions
- Where it is safe to allow the motorcycle to briefly coast.

Riding mode selection whilst the motorcycle is in motion **MUST NOT** be attempted:

- At high speeds
- Whilst riding in traffic
- During cornering or on winding roads or surfaces
- On steeply inclined roads or surfaces
- In poor road/weather conditions
- Where it is unsafe to allow the motorcycle to coast.

Failure to observe this important warning will lead to loss of motorcycle control and an accident.

Warning

After selecting a riding mode, operate the motorcycle in an area free from traffic to gain familiarity with the new settings.

Do not loan your motorcycle to anyone as they may change the riding mode setting from the one you are familiar with, causing loss of motorcycle control and an accident.

Note

Street Scrambler Only

OFF ROAD mode is not available to select when riding the motorcycle. It can only be selected when the motorcycle is stationary.

OFF ROAD mode can be switched off by a long press on the MODE button which then selects ROAD mode.

Press and release the MODE button on either the left or right hand handlebar switch housing (model specific) until the required riding mode is flashing in the display.

Within 30 seconds of pressing the MODE button the rider must carry out the following simultaneously:

- Close the throttle.
- Pull the clutch in.
- Make sure that the brakes are not engaged (allow the motorcycle to coast).

Note

The last riding mode selected before the ignition is switched OFF will be the same riding mode active when the ignition is switched ON again.

In the event of an incomplete riding mode change:

- Safely bring the motorcycle to a stop.
- Select neutral gear.
- Turn the ignition OFF and then back ON again.
- Select the required riding mode.
- Restart the engine and continue riding.

Warning

Do not stop the engine using the ignition switch or engine start/stop switch whilst the motorcycle is moving. Always bring the motorcycle to a stop safely and engage neutral gear prior to stopping the engine.

Stopping the engine by turning off the ignition or engine start/stop switch whilst the motorcycle is moving can lock the rear wheel causing loss of motorcycle control and an accident.

Caution

Do not stop the engine using the ignition switch or engine start/stop switch whilst the motorcycle is moving. Stopping the engine by turning off the ignition or engine start/stop switch when the motorcycle is moving may cause damage to motorcycle components.

Traction Control (TC)

Warning

Traction control is not a substitute for riding appropriately for the prevailing road and weather conditions.

The traction control cannot prevent loss of traction due to:

- Excessive speed when entering turns
- Accelerating at a sharp lean angle
- Braking
- Traction control cannot prevent the front wheel from slipping.

Failure to observe any of the above may result in loss of motorcycle control and an accident.

Traction control helps to maintain traction when accelerating on wet/slippery road surfaces. If sensors detect that the rear wheel is losing traction (slipping), the traction control system will engage and alter the engine power until traction to the rear wheel has been restored. The traction control warning light will flash while it is engaged and the rider may notice a change to the sound of the engine.

Note

Traction control will not function if there is a malfunction with the ABS system. The warning lights for the ABS, traction control and the MIL will be illuminated.

Note

Street Scrambler Only

Traction control is switched off when in OFF ROAD mode.

General Information

Traction Control Settings

Warning

Do not attempt to adjust the traction control settings while the motorcycle is in motion as this may lead to loss of motorcycle control and an accident.

Warning

If the traction control is disabled, the motorcycle will handle as normal but without traction control. In this situation accelerating too hard on wet/slippery road surfaces may cause the rear wheel to slip, and may result in loss of motorcycle control and an accident.

The traction control can be set to one of the following conditions:

ON	Optimal traction control setting for road use, allows minimal rear wheel slip.
OFF	Traction control is turned OFF. The TC disabled warning light will be illuminated (see page 38).

Traction control defaults to ON after the ignition has been switched OFF and then switched ON again.

To Disable the Traction Control

To disable the traction control setting:

- Make sure the motorcycle is stationary and in neutral.
- Turn the ignition to the ON position and put the engine start/stop switch in the RUN position.

- Press and release the SCROLL button on the left hand handlebar switch housing until 'ttcOn' is shown in the display.
- Press and hold the SCROLL button for more than one second to change between traction control on and traction control off.

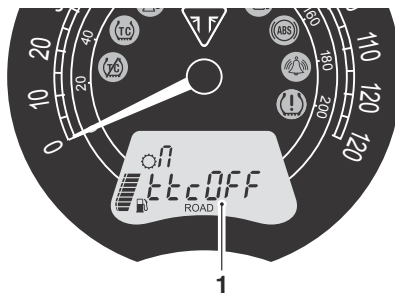

1. Traction control off display (Street Twin shown)

Warning

After riding off-road with traction control disabled, always make sure that the traction control is enabled when returning to ride on public roads.

Riding on public roads with the traction control disabled may, if accelerating too hard on wet/slippery road surfaces, cause the rear wheel to slip resulting in loss of motorcycle control and an accident.

ABS Disable and Enable - Thruxton and Thruxton R Models Only

Warning

Do not attempt to adjust the ABS settings while the motorcycle is in motion as this may lead to loss of motorcycle control and an accident.

Warning

If the ABS is disabled, the brake system will function as a non-ABS braking system. In this situation braking too hard will cause the wheels to lock, and may result in loss of motorcycle control and an accident.

Warning

After riding off-road with ABS disabled, always make sure that the ABS is enabled when returning to ride on public roads.

Riding on public roads with the ABS disabled will, if braking too hard, cause the wheels to lock resulting in loss of motorcycle control and an accident.

ABS Disable

It is possible to temporarily disable the ABS. The ABS cannot be permanently disabled, it will be enabled when the ignition is turned off and then on again.

To disable the ABS:

- Make sure the motorcycle is stationary and in neutral. Turn the ignition to the ON position and put the engine start/stop switch in the RUN position.
- Press and release the SCROLL button until 'AbSON' is shown in the left hand display.
- Press and hold the SCROLL button for one second to change between ABS on and ABS off.
- The display shows 'AbSOFF' when the ABS is disabled, and the ABS warning light will be illuminated.

Note

With the ABS disabled, the traction control will still function (unless traction control has been manually disabled).

ABS Enable

To enable the ABS, do one of the following:

- Repeat the ABS disable procedure and select 'AbSON'.
- Turn the ignition OFF and then ON.

Note

The ABS will be enabled when the motorcycle reaches a speed exceeding 6 mph (10 km/h). The ABS warning light will turn off.

General Information

Tyre Pressure Monitoring System (TPMS) (if fitted)



Warning

The daily check of tyre pressures must not be excluded because of the fitment of the TPMS. Check the tyre pressure when the tyres are cold using an accurate tyre pressure gauge (see page 133).

Use of the TPMS system to set inflation pressures may lead to incorrect tyre pressures leading to loss of motorcycle control and an accident.

Note

Tyre Pressure Monitoring System (TPMS) is an accessory option only available on models fitted with cast alloy wheels.

Function

Tyre pressure sensors are fitted to the front and rear wheels. These sensors measure the air pressure inside the tyre and transmit pressure data to the instruments. These sensors will not transmit the data until the motorcycle is travelling at a speed greater than 12 mph (20 km). Two dashes will be shown in the display screen until the tyre pressure signal is received.

The Tyre Pressure Monitoring System (TPMS) is an accessory fitted item and must be fitted by your authorised Triumph dealer.

The TPMS display screen on the instruments will only be activated when the system has been fitted.

An adhesive label will be fitted to the wheel rim to indicate the position of the tyre pressure sensor which is near the valve.

Tyre Pressure Sensor Serial Number

The serial number for the tyre pressure sensor is printed on a label attached to the sensor. This number may be required by your authorised Triumph dealer for service or diagnostics.

When the tyre pressure monitoring system is being fitted to the motorcycle, make sure that your authorised Triumph dealer records the serial numbers of the front and rear tyre pressure sensors in the spaces provided below.

Front Tyre Pressure Sensor

Rear Tyre Pressure Sensor

System Display

Warning

Do not attempt to switch between front and rear tyre display modes with the motorcycle in motion as this may lead to loss of motorcycle control and an accident.

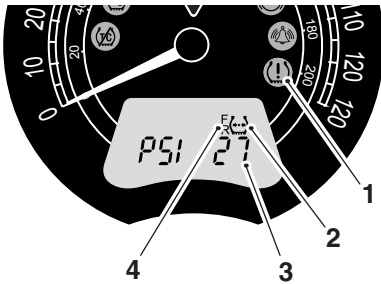

1. **TPMS warning light**
2. **TPMS symbol**
3. **Tyre pressure**
4. **Front and rear tyre indicators**

To view the tyre pressure display:

- Make sure the motorcycle is stationary and in neutral. Turn the ignition to the ON position.
- Press and release the SCROLL button until PSI or bAr is shown in the display screen.
- Press and hold the SCROLL button for one second to change between PSI and bar.
- Once PSI or bar has been selected, press and release the SCROLL button to select the front or rear tyre pressure.

- When the tyre pressure monitoring system has been selected, -- PSI or bAr is shown in display screen until the motorcycle is travelling at a speed greater than 12 mph (20 km/h) and the tyre pressure signal is received.
- To exit the tyre pressure display, press and release the SCROLL button until the desired display screen is shown.

Sensor Batteries

When the battery voltage in a pressure sensor is low, LO bAt will be displayed and the TPMS symbol will indicate which wheel sensor has the low battery voltage. If the batteries are completely flat, only dashes will be visible in the display screen, the red TPMS warning light will be on and the TPMS symbol will flash continuously. Contact your authorised Triumph dealer to have the sensor replaced and the new serial number recorded in the spaces provided on page 52.

With the ignition switch turned to the ON position, if the TPMS symbol flashes for 10 seconds and then remains on there is a fault with the TPMS system. Contact your authorised Triumph dealer to have the fault rectified.

General Information

Tyre Pressures

Warning

The tyre pressure monitoring system is not to be used as a tyre pressure gauge when adjusting the tyre pressures. For correct tyre pressures, always check the tyre pressures when the tyres are cold using an accurate tyre pressure gauge (see page 175).

Use of the TPMS system to set inflation pressures may lead to incorrect tyre pressures leading to loss of motorcycle control and an accident.

The tyre pressures shown on your instrument panel indicate the actual tyre pressure at the time of selecting the display. This may differ from the inflation pressure set when the tyres are cold because tyres become warmer during riding, causing the air in the tyre to expand and the inflation pressure to increase. The cold inflation pressures specified by Triumph take account of this.

Only adjust tyre pressures when the tyres are cold using an accurate tyre pressure gauge (see page 133). Do not use the tyre pressure display on the instruments.

Replacement Tyres

When replacing tyres, always have an authorised Triumph dealer fit your tyres and make sure they are aware that tyre pressure sensors are fitted to the wheels.

Ignition Switch/Steering Lock

Warning

For reasons of security and safety, always turn the ignition to the OFF or PARK position and remove the key when leaving the motorcycle unattended.

Any unauthorised use of the motorcycle may cause injury to the user, other road users and pedestrians and may also cause damage to the motorcycle.

Warning

With the key in the LOCK or P position the steering will become locked.

Never turn the key to the LOCK or P positions while the motorcycle is moving as this will cause the steering to lock. Locked steering will cause loss of motorcycle control and an accident.

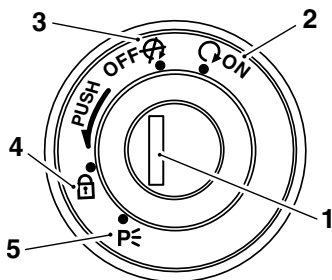

1. Ignition switch/Steering lock
2. ON position
3. OFF position
4. LOCK position
5. PARK position

Switch Operation

This is a four position, key operated switch. The key can be removed from the switch only when it is in the OFF, LOCK or P (PARK) position.

TO LOCK: Turn the steering fully to the left, turn the key to the OFF position, push and fully release the key, then rotate it to the LOCK position.

PARKING: Turn the key from the LOCK position to the P position. The steering will remain locked.

Note

Do not leave the steering lock in the P position for long periods of time as this will cause the battery to discharge.

Engine Immobiliser

The ignition switch housing acts as the antenna for the engine immobiliser.

When the ignition switch is turned to the OFF position and the ignition key is removed, the engine immobiliser is on (see page 37). The engine immobiliser is turned off when the ignition key is in the ignition switch and it is turned to the ON position.

Ignition Key

Warning

Additional keys, key rings/chains or items attached to the ignition key may interfere with the steering, leading to loss of motorcycle control and an accident.

Remove all additional keys, key rings/chains and items from the ignition key before riding the motorcycle.

Caution

Additional keys, key rings/chains or items attached to the ignition key may cause damage to the motorcycle's painted or polished components.

Remove all additional keys, key rings/chains and items from the ignition key before riding the motorcycle.

Caution

Do not store the spare key with the motorcycle as this will reduce all aspects of security.

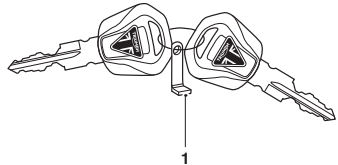

1. Key number tag

In addition to operating the ignition switch/steering lock, the ignition key is required to operate the seat lock and fuel tank cap.

When the motorcycle is delivered from the factory, two ignition keys are supplied together with a small tag bearing the key number. Make a note of the key number and store the spare key and key number tag in a safe place away from the motorcycle.

General Information

A transponder is fitted within the ignition keys to turn off the engine immobiliser. To make sure the immobiliser functions correctly, always have only one of the ignition keys near the ignition switch. Having two ignition keys near the switch may interrupt the signal between the transponder and the engine immobiliser. In this situation the engine immobiliser will remain active until one of the ignition keys is removed.

Always get replacement keys from your authorised Triumph dealer. Replacement keys must be 'paired' with the motorcycle's immobiliser by your authorised Triumph dealer.

Right Handlebar Switches

Speed Twin, Street Scrambler, Street Twin and Thruxton R

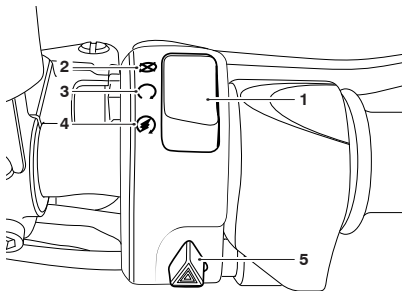

1. Engine start/stop switch
2. STOP position
3. RUN position
4. START position
5. Hazard warning light switch

Bonneville T100, Bonneville T120, Bonneville T120 Ace, Bonneville T120 Diamond and Thruxton

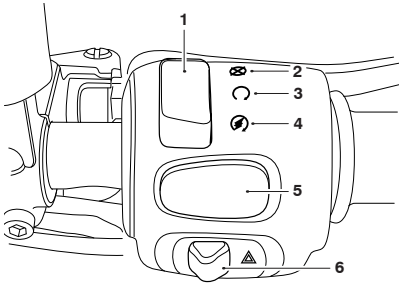

1. Engine start/stop switch
2. STOP position
3. RUN position
4. START position
5. MODE button (All models except Bonneville T100)
6. Hazard warning light switch

STOP Position

The STOP position is for emergency use. If an emergency arises which requires the engine to be stopped, move the engine start/stop switch to the STOP position.

Caution

Do not leave the ignition switch in the ON position unless the engine is running as this may cause damage to electrical components and will discharge the battery.

Note

Although the engine stop switch stops the engine, it does not turn off all the electrical circuits and may cause difficulty in restarting the engine due to a discharged battery. Ordinarily, only the ignition switch should be used to stop the engine.

RUN Position

In addition to the ignition switch being turned to the ON position, the engine start/stop switch must be in the RUN position for the motorcycle to operate.

START Position

The START position operates the electric starter. For the starter to operate, the clutch lever must be pulled to the handlebar.

Note

Even if the clutch lever is pulled to the handlebar, the starter will not operate if the side stand is down and a gear is engaged.

MODE Button (if fitted)

The MODE button allows throttle response adjustment. Press and release the MODE button to select one of the different rider modes available (see page 46 for more information).

Hazard Warning Lights

To turn the hazard warning lights on or off, press and release the hazard warning light switch.

The ignition must be switched ON for the hazard warning lights to function.

General Information

The hazard warning lights will remain on if the ignition is switched off, until the hazard warning light switch is pressed again.

Left Handlebar Switches

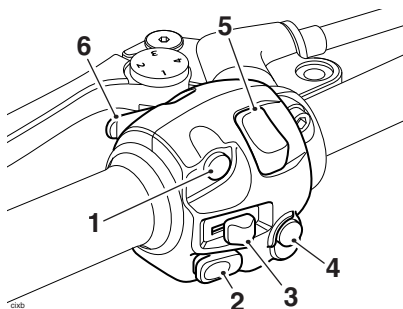

1. **SCROLL button**
2. **Horn button**
3. **Direction indicator switch**
4. **MODE button (Speed Twin, Street Scrambler, Street Twin and Thruxton R only)**
5. **Daytime Running Lights (DRL) switch (if fitted)**
6. **High beam button**

SCROLL Button

The SCROLL button is used to operate the following functions of the instruments:

- Odometer functions (see page 44)
- Trip reset (see page 44)
- Clock reset (see page 45)
- Traction control functions (see page 49).

Horn Button

When the horn button is pushed, with the ignition switch turned on, the horn will sound.

Direction Indicator Switch

When the direction indicator switch is pushed to the left or right, the corresponding direction indicators will flash on and off.

The indicators can be cancelled manually. To manually turn off the indicators, press and release the indicator switch in the central position.

MODE Button (if fitted)

The MODE button allows throttle response adjustment. Press and release the MODE button to select one of the different rider modes available (see page 46 for more information).

Daytime Running Lights (DRL) Switch (if fitted)

Note

Daytime running lights are manually operated. They are not automatic.

The daytime running lights or dip beam can be selected with the Daytime Running Lights (DRL) switch.

To select daytime running lights, push the DRL switch forward.

To select dip beam, push the DRL switch rearwards.

When the daytime running lights are turned on, the daytime running lights indicator light will illuminate in the instrument panel.

High Beam Light



When the high beam button is pressed the high beam will be switched on. Each press of the button will swap between dip and high beam.

Note

If daytime running lights are fitted to the motorcycle, the high beam button has additional functionality.

If the DRL switch is in the daytime running lights position, then press and hold the high beam button to turn the high beam on. It will remain on as long as the button is held in and will turn off as soon as the button is released.

Note

A lighting on/off switch is not fitted to this model. The rear light and licence plate light all function automatically when the ignition is on.

The headlight will function when the ignition is on. The headlight will go off while pressing the starter button until the engine starts.

General Information

Heated Grips (if fitted)

The heated grips work when the ignition is switched on. However, it is recommended that they are only used when the engine is running to avoid draining the battery.

There are two heat levels; low or high.

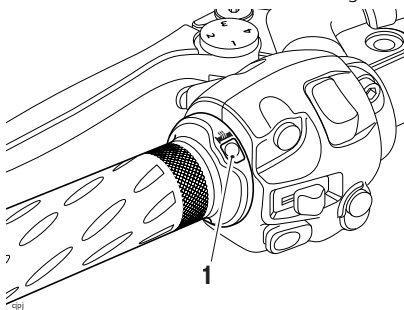

1. Heated grips button

The heated grips button is located on the left hand grip.

Press the heated grip button to show the current status of the heated grips in the display screen. This is shown for three seconds.

Press the heated grip button whilst the status is showing to select one of the three different heat levels; OFF, Lo (low) or HI (high).

For maximum benefit in cold conditions, use the heated grips on the HI level initially and when the grips have warmed up, change to Lo.

To switch off the heated grips, press and release the button until OFF is shown in the display screen. The heated grips are also switched off when the ignition is switched off.

Low Battery Warning

If heated grips are fitted and are on with the engine not running, over a period of time, the battery voltage may drop below 11.8 Volts and 'LoBAtt' is then shown in the display screen for three seconds.

If the heated grips are on and 'LoBAtt' is shown, then the heated grips are automatically switched off to prevent further discharge of the battery. It is not possible to resume heated grip operation until the engine has been running and the battery voltage has increased above 11.8 Volts.

In the event of a fault, 'HgrOFF' is shown in the display screen and the heated grips are automatically switched off. The heated grips can be switched back on by:

- waiting 25 seconds then switch on the heated grip, or
- turning the ignition switch to the OFF position then back to the ON position.

If 'HgrOFF' remains shown in the display screen, then contact an authorised Triumph dealer to have the fault checked and rectified.

Throttle Control

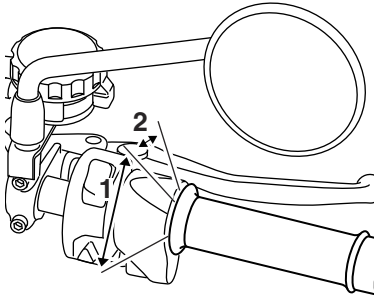

1. Throttle open position
2. Throttle closed position

All models have an electronic throttle twist grip to open and close the throttles via the engine control unit. There are no direct-acting cables in the system.

The throttle grip has a resistive feel to it as it is rolled rearwards to open the throttles. When the grip is released it will return to the throttle closed position by its internal return spring and the throttles will close.

There are no user adjustments for the throttle control.

If there is a malfunction with the throttle control the Malfunction Indicator Light (MIL) becomes illuminated and one of the following engine conditions may occur:

- MIL illuminated, restricted engine RPM and throttle movement
- MIL illuminated, limp-home mode with the engine at a fast idle condition only
- MIL illuminated, engine will not start.

For all of the conditions mentioned contact an authorised Triumph dealer as soon as possible to have the fault checked and rectified.

General Information

Clutch Lever Adjusters

Warning

Do not attempt to adjust the levers with the motorcycle in motion as this may lead to loss of motorcycle control and an accident.

After adjusting the levers, operate the motorcycle in an area free from traffic to gain familiarity with the new lever setting.

Do not loan your motorcycle to anyone as they may change the lever setting from the one you are familiar with causing loss of motorcycle control and an accident.

An adjuster is fitted to the front clutch lever. The adjuster allows the distance from the handlebar to the clutch lever to be changed to suit the span of the rider's hands.

Speed Twin Only

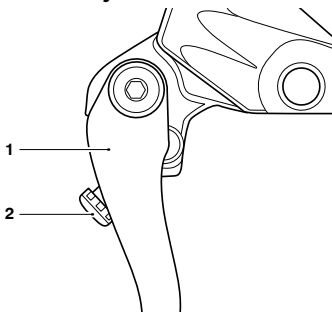

1. Clutch lever
2. Adjusting screw

To adjust the clutch lever:

- Push the clutch lever forward and turn the adjusting screw in to increase the distance or out to shorten the distance from the handlebar.

All Other Models

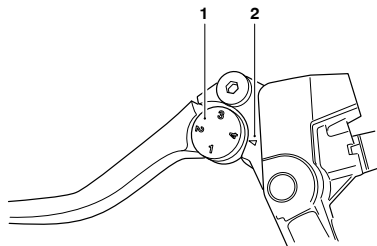

1. Clutch lever adjuster wheel
2. Arrow mark

To adjust the clutch lever:

- Push the clutch lever forward and turn the adjuster wheel to align one of the numbered positions with the arrow mark on the clutch lever holder.
- The distance from the handlebar grip to the released clutch lever is shortest when set to number four, and longest when set to number one.

Brake Lever Adjusters

Warning

Do not attempt to adjust the levers with the motorcycle in motion as this may lead to loss of motorcycle control and an accident.

After adjusting the levers, operate the motorcycle in an area free from traffic to gain familiarity with the new lever setting.

Do not loan your motorcycle to anyone as they may change the lever setting from the one you are familiar with causing loss of motorcycle control and an accident.

An adjuster is fitted to the front brake lever. The adjuster allows the distance from the handlebar to the brake lever to be changed to suit the span of the rider's hands.

Speed Twin and Thruxton R Only

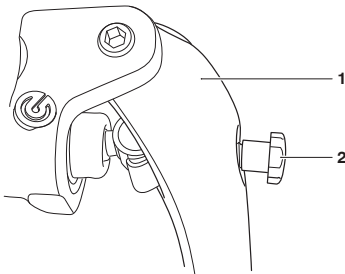

1. Brake lever
2. Adjusting screw

To adjust the brake lever:

- Push the brake lever forward and turn the adjusting screw in to increase the distance or out to shorten the distance from the handlebar.

All Other Models

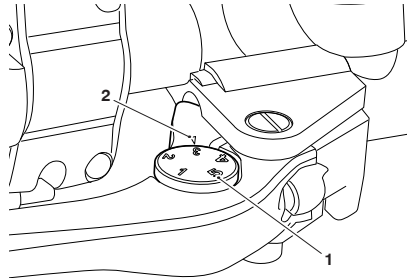

1. Brake lever adjuster wheel
2. Arrow mark

To adjust the brake lever:

- Push the brake lever forward and turn the adjuster wheel to align one of the numbered positions with the arrow mark on the brake lever holder.
- The distance from the handlebar grip to the released brake lever is shortest when set to number five, and longest when set to number one.

General Information

Fuel

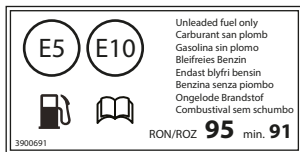

Fuel Grade

Triumph motorcycles are designed to use unleaded fuel and will give optimum performance if the correct grade of fuel is used. Always use unleaded fuel with a minimum octane rating of 91 RON.

Ethanol

In Europe, Triumph motorcycles are compatible with Ethanol E5 and E10 (5% and 10% Ethanol) unleaded fuel.

In all other markets Ethanol up to E25 (25% Ethanol) may be used.

Engine Calibration

In certain circumstances engine calibration may be required. Always refer to your authorised Triumph dealer.

⚠ Caution

The motorcycle can be permanently damaged if it is allowed to operate with the incorrect grade of fuel or incorrect engine calibration.

Always make sure the fuel used is of the correct grade and quality.

Damage caused by using the incorrect fuel or engine calibration is not considered a manufacturing defect and will not be covered under warranty.

⚠ Caution

The exhaust system for this motorcycle is fitted with a catalytic converter to help reduce exhaust emission levels.

Use of leaded fuel will damage the catalytic converter. In addition, the catalytic converter can be permanently damaged if the motorcycle is allowed to run out of fuel or if the fuel level is allowed to get very low.

Always make sure you have adequate fuel for your journey.

Note

The use of leaded fuel is illegal in some countries, states or territories.

Refuelling

Warning

To help reduce hazards associated with refuelling, always observe the following fuel safety instructions:

- Petrol (fuel) is highly flammable and can be explosive under certain conditions. When refuelling, turn the ignition switch to the OFF position.
- Do not smoke.
- Do not use a mobile telephone.
- Make sure the refuelling area is well ventilated and free from any source of flame or sparks. This includes any appliance with a pilot light.
- Never fill the tank until the fuel level rises into the filler neck. Heat from sunlight or other sources may cause the fuel to expand and overflow creating a fire hazard.
- After refuelling always check that the fuel filler cap is correctly closed.
- Because petrol (fuel) is highly flammable, any fuel leak or spillage, or any failure to observe the safety advice given above will lead to a fire hazard, which could cause damage to property, injury to persons or death.

Fuel Tank Cap

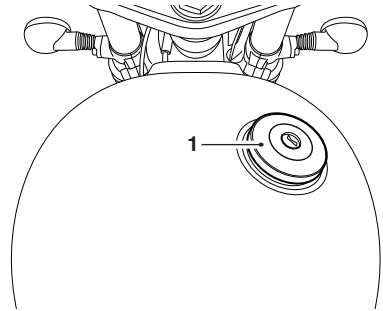

1. Fuel tank cap

To open the fuel tank cap:

- Remove the cover or lift up the flap.
- Insert the key into the lock and turn the key clockwise.
- Rotate the cap anticlockwise and lift clear of the tank filler neck.

To close and lock the cap:

- Align the cap to the tank filler neck and rotate the cap clockwise until the cap seals against the filler neck.
- In the fully closed position, a ratchet mechanism prevents overtightening of the cap by allowing the outer part of the cap to turn independently of the internal part.
- Turn the key anticlockwise to lock and withdraw the key.
- Replace the cover or securely close the flap.

General Information

Filling the Fuel Tank

Warning

Overfilling the tank can lead to fuel spillage.

If fuel is spilled, thoroughly clean up the spillage immediately and dispose of the materials used safely.

Take care not to spill any fuel on the engine, exhaust pipes, tyres or any other part of the motorcycle.

Because fuel is highly flammable, any fuel leak or spillage, or any failure to observe the safety advice given above may lead to a fire hazard, which could cause damage to property and injury or death to persons.

Fuel spilled near to, or onto the tyres will reduce the tyres' ability to grip the road. This will result in a dangerous riding condition potentially causing loss of motorcycle control and an accident.

Caution

Avoid filling the tank in rainy or dusty conditions where airborne material can contaminate the fuel.

Contaminated fuel may cause damage to fuel system components.

Fill the fuel tank slowly to help prevent spillage. Do not fill the tank to a level above the bottom of the filler neck. This will make sure there is enough air space to allow for fuel expansion if the fuel inside the tank expands through absorption of heat from the engine or from direct sunlight.

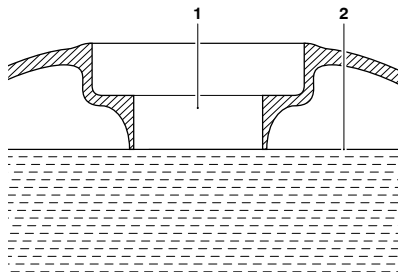

1. **Fuel filler neck**
2. **Maximum fuel level**

After refuelling always check that the fuel filler cap is correctly closed.

Side Stand

Warning

The motorcycle is fitted with an interlock system to prevent it from being ridden with the side stand in the down position.

Never attempt to ride with the side stand down or interfere with the interlock mechanism as this will cause a dangerous riding condition leading to loss of motorcycle control and an accident.

Warning

Do not lean, sit or climb on the motorcycle when it is supported on the side stand.

This may cause the motorcycle to fall over leading to motorcycle damage and an accident.

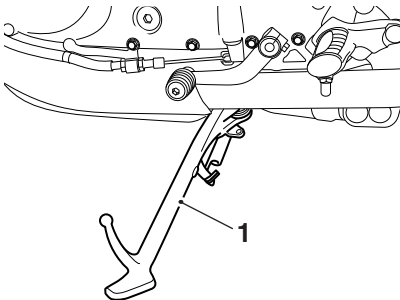

1. Side stand

The motorcycle is equipped with a side stand on which it can be parked. When using the side stand, always turn the handlebars fully to the left and leave the motorcycle in first gear.

Whenever the side stand is used, before riding, always make sure that the stand is fully up after first sitting on the motorcycle.

For instructions on safe parking, refer to the 'How to Ride the Motorcycle' section.

General Information

Centre Stand (if fitted)

Caution

Do not use body panels or the seat as a handhold when placing the motorcycle on the centre stand as this will cause damage.

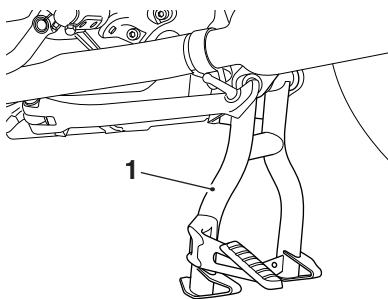

1. Centre stand

To set the motorcycle on the centre stand, hold the motorcycle upright, step down firmly on the foot finder part of the stand, then lift the motorcycle up and to the rear using the rear frame as a handhold.

For instructions on safe parking, refer to the How to Ride the Motorcycle section.

Side Panels

All Models except Street Scrambler

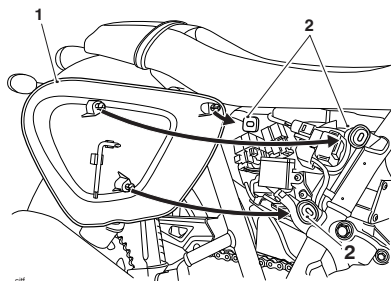

1. Side panel (right hand shown)
2. Grommets

The right side panel can be removed to gain access to the adjustment tool and the rear brake fluid reservoir.

To remove either side panel:

- Grasp the panel firmly and pull the panel away from the motorcycle until it is free from the three retaining grommets (leaving the grommets in place).

To refit either side panel:

- Position the three locating dowels to the grommets, then press firmly to secure the panel.
- Finally, grasp the panel and make sure that it is fully retained.

Street Scrambler

Left Hand Side Panel

The left hand side panel can be removed to gain access to the adjustment tool.

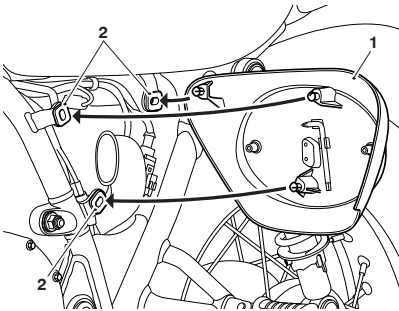

1. Side panel (left hand shown)
2. Grommets

To remove the left hand side panel:

- Grasp the panel firmly and pull the panel away from the motorcycle until it is free from the three retaining grommets (leaving the grommets in place).

To refit the left hand side panel:

- Position the three locating dowels to the grommets, then press firmly to secure the panel.
- Finally, grasp the panel and make sure that it is fully retained.

Right Hand Side Panel

The right hand side panel can be removed to gain access to the rear brake fluid reservoir.

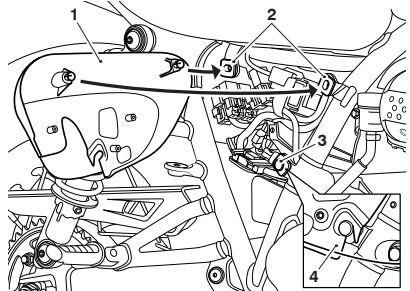

1. Side panel (right hand shown)
2. Upper grommets
3. Lower grommets
4. Side panel attached to lower grommet

Note

The exhaust system is shown removed for clarity.

To remove the right hand side panel:

- Grasp the panel firmly at the top and pull the panel away from the motorcycle until it is free from the two top retaining grommets, leaving the grommets in place.
- Lift up the panel to detach it from the lower grommet.

To refit the right hand side panel:

- Position the side panel on to the lower grommet.
- Make sure that the slot in the panel is fully engaged with the lower grommet.
- Position the two locating dowels to the upper grommets, then press firmly to secure the panel.
- Finally, grasp the panel and make sure that it is fully retained.

General Information

Tool Kit and Owner's Handbook

Tool Kit

The tool kit consists of an adjustment tool for all models, and additional C-spanners for Thruxton R.

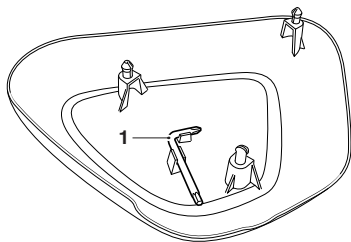

1. Adjustment tool

Bonneville T100, Bonneville T120, Bonneville T120 Ace, Bonneville T120 Diamond, Speed Twin, Street Twin, Thruxton and Thruxton R

The adjustment tool is attached to the inside of the right hand side panel.

Street Scrambler

The adjustment tool is attached to the inside of the left hand side panel.

Thruxton R

There are two C-spanners located under the seat.

Owner's Handbook

Bonneville T100, Bonneville T120, Bonneville T120 Diamond, Thruxton and Thruxton R

The Owner's Handbook is located under the seat on the rear mudguard.

Bonneville T120 Ace, Speed Twin and Street Scrambler

The Owner's Handbook is supplied separately.

Street Twin

The Owner's Handbook is located on the underside of the seat.

Helmet Hook (if fitted)

Warning

Never ride the motorcycle with helmet(s) secured to the helmet hook as this may cause the motorcycle to become unstable leading to loss of control and an accident.

Caution

Do not allow helmet(s) to rest against a hot silencer. The helmet may be damaged.

A helmet can be secured to the motorcycle using the helmet hook located on the left hand side of the motorcycle, beneath the seat.

To attach a helmet to the motorcycle:

- Remove the seat (see page 72) and loop the helmet chin strap over the hook.
- Make sure the flat area above the hook is not obstructed by the helmet strap, as this will prevent the seat engaging correctly.
- To secure the helmet, refit the seat and lock into position.

Seats

Seat Care

Caution

To prevent damage to the seats or seat covers, care must be taken not to drop the seats.

Do not lean the seats against the motorcycle or any surface which may damage the seats or seat covers. Instead, place the seats, with the seat cover facing upwards, on a clean, flat surface which is covered with a soft cloth.

Do not place any item on the seats which may cause damage or staining to the seat covers.

Thruxton and Thruxton R

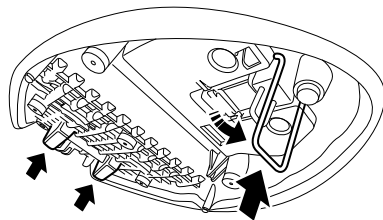

cpal

Seat Stand

To prevent damage to the seat after removing:

- Release the metal stand from the underside of the seat.

General Information

- Place the seat cover facing upwards, on a clean, flat surface using the metal stand and two plastic stands at the rear of the seat to rest on.
- See page 155 for seat cleaning information.

Seat Lock

Warning

To prevent detachment of the seat during riding, after fitting always grasp the seat and pull firmly upwards. If the seat is not correctly secured in the lock, it will detach from the lock.

A loose or detached seat could cause loss of motorcycle control and an accident.

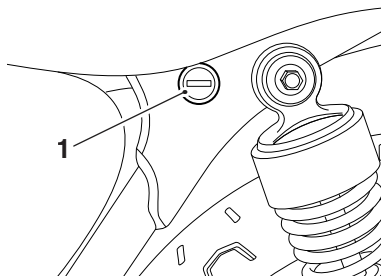

1. Seat lock

The seat lock is located on the left hand side of the motorcycle, on the frame below the seat.

The seat can be removed to gain access to the battery, fuse box (on certain models) and Owner's Handbook.

Seat Removal and Installation

Warning

To prevent detachment of a seat during riding, after fitting always grasp the seat and pull firmly upwards.

If the seat is not correctly secured it will detach from the lock.

A loose or detached seat could cause loss of motorcycle control and an accident.

All Models except Street Scrambler

Seat Removal

To remove the seat:

- Insert the ignition key into the seat lock and turn it anticlockwise. This will release the seat from its lock.
- Slide the seat upwards and rearwards for complete removal from the motorcycle.

Seat Installation

To refit the seat:

- Engage the seat's tongue underneath the bracket near the fuel tank.
- Line up the hinges and press down at the rear to engage the seat lock.

Note

An audible click can be heard when the seat is fully engaged into its lock.

Street Scrambler Seat Removal

Note

If a passenger seat is fitted, it must be removed before removing the rider's seat.

If a luggage rack is fitted, the rider's seat can be removed without removing the luggage rack.

Passenger Seat Removal

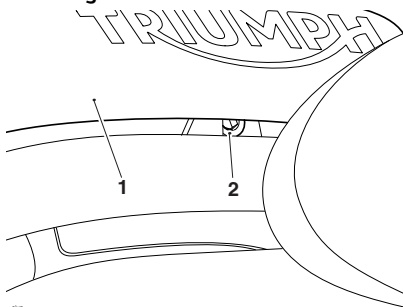

1. Passenger seat
2. Fixing

To remove the passenger seat:

- Remove the fixing securing the passenger seat to the luggage rack subframe.
- Lift the seat up from the back and slide rearwards to remove it from the motorcycle.

Rider's Seat Removal

To remove the rider's seat:

- Remove the passenger seat if fitted.
- Insert the ignition key into the seat lock and turn it anticlockwise while pressing down on the rear of the seat. This will release the seat from its lock.

- Lift the seat up from the back and slide rearwards to remove it from the motorcycle.

Street Scrambler Seat Installation

Warning

To prevent detachment of a seat during riding, after fitting always grasp the seat and pull firmly upwards. If the seat is not correctly secured it will detach from the lock.

If the seat is not correctly secured it will detach from the lock.

A loose or detached seat could cause loss of motorcycle control and an accident.

Rider's Seat Installation

To install the rider's seat:

- Engage the seat's tongue under the fuel tank.
- Press firmly down in the centre of the seat to engage the lock.

Note

An audible click can be heard when the seat is correctly engaged in the lock.

- Grasp the seat and make sure it is securely retained.

Passenger Seat Installation

To install the passenger seat:

- Make sure that the rider's seat is correctly fitted.
- Align the front locating lugs on the passenger seat to their locating slots on the luggage rack subframe.

General Information

- Gently push the seat forward until the rear locating lug fits into its hole on the luggage rack subframe.

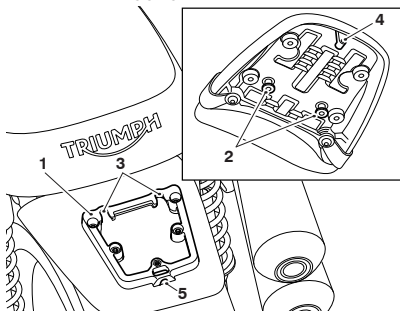

1. Luggage rack subframe
2. Front locating lugs
3. Front locating lug slots
4. Rear locating lug
5. Rear locating lug hole

- Secure the seat with its fixing and tighten to 3 Nm.

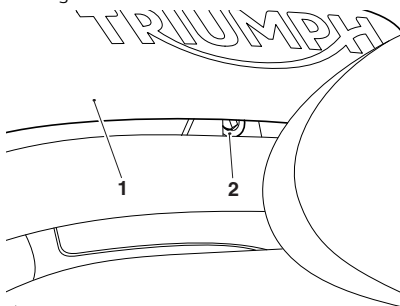

1. Passenger seat
2. Fixing

- Grasp the seat and make sure that it is securely retained.

Luggage Rack

Street Scrambler Only

Note

If a luggage rack is fitted, the rider's seat can be removed without removing the luggage rack.

Removal

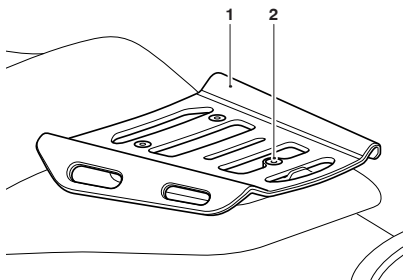

1. Luggage rack
2. Screw

To remove the luggage rack:

- Remove the screw securing the luggage rack to the luggage rack subframe.
- Lift the luggage rack up from the back and slide rearwards to remove it from the luggage rack subframe.

Installation

To install the luggage rack:

- Make sure that the rider's seat is correctly fitted.
- Align the front locating lugs on the luggage rack to their locating slots on the luggage rack subframe.

- Gently push the luggage rack forward until the locating lugs are secure.

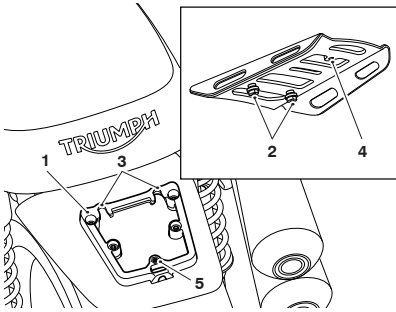

1. Luggage rack subframe
2. Locating lugs
3. Locating lug slots
4. Locating screw position
5. Locating screw hole

- Secure the luggage rack with its screw in the locating screw hole and tighten to 8 Nm.

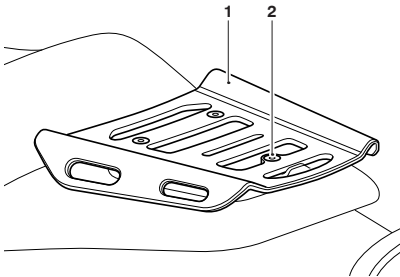

1. Luggage rack
2. Screw

- Grasp the luggage rack and make sure that it is securely retained.

Universal Serial Bus (USB) Socket

⚠ Warning

The USB socket is not waterproof unless the waterproof cap is installed. Do not connect electronic devices whilst it is raining.

Water in the USB socket could lead to an electrical problem, resulting in motorcycle damage, loss of motorcycle control and an accident.

⚠ Caution

Do not leave the ignition switch in the ON position unless the engine is running as this will discharge the battery.

General Information

⚠ Caution

Always make sure that all electronic devices and cables are safely secured under the seat when riding.

Always make sure there is sufficient space surrounding any electronic devices for the seat to close without causing any damage to the electronic device or the motorcycle.

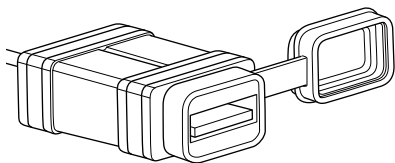

USB Port Socket

The Universal Serial Bus (USB) socket allows a 5 Volt USB connection for charging electronic devices such as mobile phones, cameras and GPS devices.

Loads up to two Amps can be connected to the USB socket.

To access the USB socket:

- Remove the seat (see page 72).
- The USB socket is located on top of the battery.
- Remove the cap.
- Plug the relevant USB adaptor cable into the socket. Adaptor cables are not supplied with the motorcycle.

Running-In



Running-in is the name given to the process that occurs during the first hours of a new vehicle's operation.

In particular, internal friction in the engine will be higher when components are new. Later on, when continued operation of the engine has ensured that the components have 'bedded in', this internal friction will be greatly reduced.

A period of careful running-in will ensure lower exhaust emissions, and will optimise performance, fuel economy and longevity of the engine and other motorcycle components.

During the first 500 miles (800 km):

- Do not use full throttle;
- Avoid high engine speeds at all times;
- Avoid riding at one constant engine speed, whether fast or slow, for a long period of time;
- Avoid aggressive starts, stops, and rapid accelerations, except in an emergency;
- Do not ride at speeds greater than 3/4 of maximum speed.

From 500 to 1,000 miles (800 to 1,500 km):

- Engine speed can gradually be increased to the rev limit for short periods.

Both during and after running-in has been completed:

- Do not overrev the engine when cold;
- Do not let the engine labour. Always downshift before the engine begins to 'struggle';
- Do not ride with engine speeds unnecessarily high. Changing up a gear helps reduce fuel consumption, reduces noise and helps to protect the environment.

Daily Safety Checks



Warning

Failure to perform these checks every day before you ride may result in serious motorcycle damage or an accident causing serious injury or death.

Check the following items each day before you ride. The time required is minimal, and these checks will help ensure a safe, reliable ride.

If any irregularities are found during these checks, refer to the Maintenance and Adjustment section or see your authorised Triumph dealer for the action required to return the motorcycle to a safe operating condition.

Check:

Fuel: Adequate supply in tank, no fuel leaks (see page 66).

Engine Oil: Correct level on dipstick or shown in sight glass. Add correct specification oil as required. No leaks from the engine or oil cooler (see page 103).

Drive Chain: Correct adjustment (see page 113).

Tyres/Wheels: Correct inflation pressures (when cold). Tread depth/wear, tyre/wheel damage, loose/broken spokes, punctures etc. (see page 132).

General Information

Nuts, Bolts, Fasteners: Visually check that steering and suspension components, axles, and all controls are properly tightened or fastened. Inspect all areas for loose/damaged fixings.

Steering Action: Smooth but not loose from lock to lock. No binding of any of the control cables (see page 124).

Brakes: Pull the brake lever and push the brake pedal to check for correct resistance. Investigate any lever/pedal where the travel is excessive before meeting resistance, or if either control feels spongy in operation (see page 117).

Brake Pads: Check that the correct amount of friction material is remaining on all the brake pads (see page 117).

Brake Fluid Levels: No brake fluid leakage. Brake fluid levels must be between the MAX and MIN marks on both reservoirs (see page 118).

Front Forks: Smooth action. No fork oil leakage (see page 128).

Throttle: Make sure that the throttle grip returns to the idle position without sticking (see page 110).

Clutch: Smooth operation and correct cable free play (see page 111).

Coolant: No coolant leakage. Check the coolant level in the expansion tank (when the engine is cold) (see page 107).

Electrical Equipment: All lights and horn function correctly (see page 58).

Engine Stop: Engine start/stop switch turns the engine OFF when the switch is moved to the STOP position (see page 56).

Stands: Returns to the fully up position by spring tension. Return springs not weak or damaged (see page 67).

How to Ride the Motorcycle

Table of Contents

How to Ride the Motorcycle.....	80
Stopping the Engine.....	81
Starting the Engine.....	81
Moving Off.....	82
Changing Gears.....	83
Braking.....	84
Anti-lock Braking System (ABS).....	86
Parking.....	88
Considerations for High Speed Operation.....	89

How to Ride the Motorcycle

How to Ride the Motorcycle

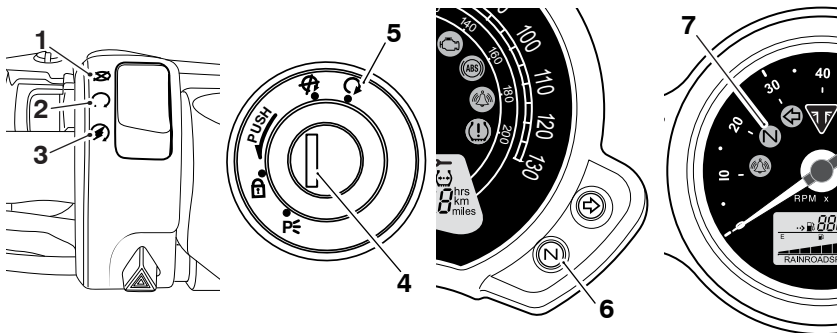

1. STOP position
2. RUN position
3. START position
4. Ignition switch
5. ON position
6. Neutral indicator light (Street Scrambler and Street Twin)
7. Neutral indicator light (all other models)

Stopping the Engine

Caution

The engine should normally be stopped by turning the ignition switch to the OFF position.

The engine stop switch is for emergency use only.

Do not leave the ignition switched on with the engine stopped. Electrical damage may result.

To stop the engine:

- Close the throttle completely.
- Select neutral.
- Turn the ignition switch off.
- Select first gear.
- Position the motorcycle on a firm, level surface with the side stand (see page 88).
- Lock the steering (see page 54).

Starting the Engine

Warning

Never start the engine or run the engine in a confined area.

Exhaust fumes are poisonous and can cause loss of consciousness and death within a short period of time.

Always operate your motorcycle in the open air or in an area with adequate ventilation.

Caution

Do not operate the starter continuously for more than five seconds as the starter motor will overheat and the battery will become discharged.

Wait 15 seconds between each operation of the starter to allow for cooling and recovery of battery power.

Do not let the engine idle for long periods as this may lead to overheating which will cause damage to the engine.

How to Ride the Motorcycle

Caution

The low oil pressure warning light should go out shortly after the engine starts.

If the low oil pressure warning light stays on after starting the engine, stop the engine immediately and investigate the cause.

Running the engine with low oil pressure will cause severe engine damage.

To start the engine:

- Check that the engine stop switch is in the RUN position.
- Make sure the transmission is in neutral.
- Turn the ignition switch on.

Note

When the ignition is switched on, the instrument warning lights will illuminate and will then go off (except those which normally remain on until the engine starts, see page 36).

- Pull the clutch lever fully into the handlebar.
- Leaving the throttle fully closed, push the starter button until the engine starts.
- The motorcycle is equipped with starter lockout switches. The switches prevent the electric starter from operating when the transmission is not in neutral with the side stand down.

- If the side stand is extended whilst the engine is running, and the transmission is not in neutral then the engine will stop regardless of the clutch lever position.

Moving Off

To move the motorcycle:

- Pull in the clutch lever and select first gear.
- Open the throttle a little and let out the clutch lever slowly.
- As the clutch starts to engage, open the throttle a little more, allowing enough engine speed to avoid stalling.

Changing Gears

Warning

Take care to avoid opening the throttle too far or too fast in any of the lower gears as this can lead to the front wheel lifting from the ground (pulling a 'wheelie') and to the rear tyre breaking traction (wheel spin).

Always open the throttle cautiously, particularly if you are unfamiliar with the motorcycle, as a 'wheelie' or loss of traction will cause loss of motorcycle control and an accident.

Warning

Do not change to a lower gear at speeds that will cause excessive engine rpm (r/min). This can lock the rear wheel causing loss of control and an accident.

Engine damage may also be caused.

Changing down should be done so that low engine speeds will be ensured.

To change gear:

- Close the throttle while pulling in the clutch lever.
- Change into the next higher or lower gear.
- Open the throttle part way, while releasing the clutch lever. Always use the clutch when changing gear.

Note

The gear change mechanism is the 'positive stop' type. This means that, for each movement of the gear change pedal/lever, you can only select each gear, one after the other, in ascending or descending order.

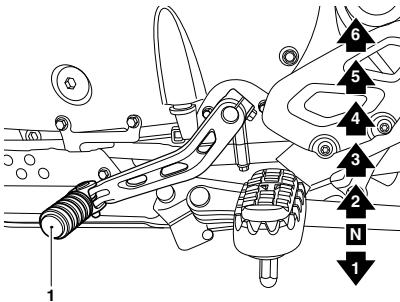

1. Gear change pedal (6 speed shown)

How to Ride the Motorcycle

Braking

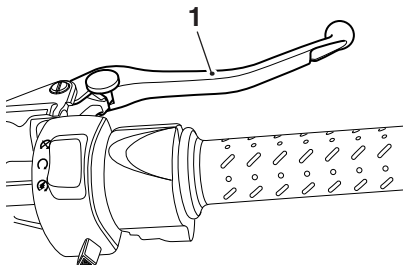

cltp

1. Front brake lever

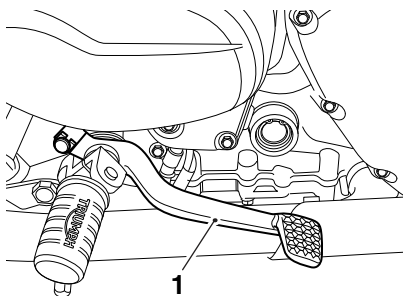

cltm

1. Rear brake pedal

Warning

WHEN BRAKING, OBSERVE THE FOLLOWING:

- Close the throttle completely, leaving the clutch engaged to allow the engine to help slow down the motorcycle.
- Change down one gear at a time such that the transmission is in first gear when the motorcycle comes to a complete stop.
- When stopping, always apply both brakes at the same time. Normally the front brake should be applied a little more than the rear.
- Change down or fully disengage the clutch as necessary to keep the engine from stalling.
- Never lock the brakes, as this may cause loss of control of the motorcycle and an accident.

Warning

For emergency braking, disregard down changing, and concentrate on applying the front and rear brakes as hard as possible without skidding. Riders should practice emergency braking in a traffic-free area.

Triumph strongly recommends that all riders take a course of instruction, which includes advice on safe brake operation. Incorrect brake technique could result in loss of control and an accident.

Warning

For your safety, always exercise extreme caution when braking (whether or not ABS is fitted), accelerating or turning as any incautious action can cause loss of control and an accident. Independent use of the front or rear brakes reduces overall braking performance. Extreme braking may cause either wheel to lock, reducing control of the motorcycle and causing an accident (see ABS warnings below).

When possible, reduce speed or brake before entering a turn as closing the throttle or braking in mid-turn may cause wheel slip leading to loss of control and an accident.

When riding in wet or rainy conditions, or on loose surfaces, the ability to manoeuvre and stop will be reduced. All of your actions should be smooth under these conditions. Sudden acceleration, braking or turning may cause loss of control and an accident.

Warning

When descending a long, steep gradient or mountain pass, make use of the engine's braking effect by down changing and use both front and rear brakes intermittently.

Continuous brake application or use of the rear brake only can overheat the brakes and reduce their effectiveness leading to loss of motorcycle control and an accident.

Warning

Riding with your foot on the brake pedal or your hands on the brake lever may actuate the brake light, giving a false indication to other road users.

It may also overheat the brake, reducing braking effectiveness leading to loss of motorcycle control and an accident.

Warning

Do not coast with the engine switched off, and do not tow the motorcycle. The transmission is pressure lubricated only when the engine is running.

Inadequate lubrication may cause damage or seizure of the transmission, which can lead to sudden loss of motorcycle control and an accident.

How to Ride the Motorcycle

Anti-lock Braking System (ABS)

Warning

ABS helps prevent the wheels from locking, therefore maximising the effectiveness of the braking system in emergencies and when riding on slippery surfaces. The potentially shorter braking distances ABS allows under certain conditions are not a substitute for good riding practice.

Always ride within the legal speed limit.

Never ride without due care and attention and always reduce speed in consideration of weather, road and traffic conditions.

Take care when cornering. If the brakes are applied in a corner, ABS will not be able to counteract the weight and momentum of the motorcycle. This can result in loss of motorcycle control and an accident.

Under some circumstances it is possible that a motorcycle equipped with ABS may require a longer stopping distance than an equivalent motorcycle without ABS.

Warning

If the ABS is not functioning or has been disabled, the brake system will continue to function as a non-ABS braking system.

Do not continue to ride for longer than is necessary with the warning light illuminated. In the event of a fault, contact an authorised Triumph dealer as soon as possible to have the fault checked and rectified.

In this situation, braking too hard will cause the wheels to lock resulting in loss of motorcycle control and an accident.

Warning

After riding off-road with ABS disabled, always make sure that the ABS is enabled when returning to ride on public roads.

Riding on public roads with the ABS disabled will, if braking too hard, cause the wheels to lock resulting in loss of motorcycle control and an accident.

Note

Normally, the rider will perceive ABS operation as a harder feel or a pulsation of the brake lever and pedal.

The ABS may be activated by sudden upward or downward changes in the road surface.

ABS Warning Light



When the ignition switch is turned to the ON position, it is normal that the ABS warning light will flash on and off. The light will continue to flash after engine start-up until the motorcycle first reaches a speed exceeding 6 mph (10 km/h) when it will go off.

The warning light will not illuminate again until the engine is restarted unless there is a fault, or the ABS is disabled by the rider.

If the ABS is disabled by the rider the warning light will illuminate until the ABS is enabled again.

If there is a fault with the ABS system the warning light will be illuminated and the general warning symbol will flash.

Warning

The ABS computer operates by comparing the relative speed of the front and rear wheels.

Use of non-recommended tyres can affect wheel speed and cause the ABS function not to operate, potentially leading to loss of control and an accident in conditions where the ABS would normally function.

Warning

The ABS warning light will illuminate when the rear wheel is driven at high speed for more than 30 seconds when the motorcycle is on a stand. This reaction is normal.

When the ignition is switched off and the motorcycle is restarted, the warning light will illuminate until the motorcycle reaches a speed exceeding 19 mph (30 km/h).

How to Ride the Motorcycle

Parking

Warning

Do not park on a soft or on a steeply inclined surface. Parking under these conditions may cause the motorcycle to fall over causing damage to property and personal injury.

Warning

Petrol is extremely flammable and can be explosive under certain conditions. If parking inside a garage or other structure, be sure it is well ventilated and the motorcycle is not close to any source of flame or sparks. This includes any appliance with a pilot light.

Failure to follow the above advice may cause a fire resulting in damage to property or personal injury.

Warning

The engine and exhaust system will be hot after riding. DO NOT park where pedestrians and children are likely to touch the motorcycle.

Touching any part of the engine or exhaust system when hot may cause unprotected skin to become burnt.

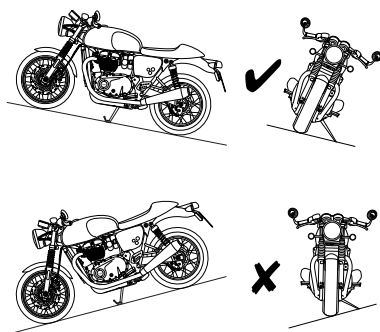

To park the motorcycle:

- Select neutral and turn the ignition switch to the OFF position.
- Lock the steering to help prevent theft.
- Always park on a firm, level surface to prevent the motorcycle from falling.
- When parking on a hill, always park facing uphill to prevent the motorcycle from rolling off the stand. Engage first gear to prevent the motorcycle from moving.

How to Ride the Motorcycle

- On a lateral (sideways) incline, always park such that the incline naturally pushes the motorcycle towards the sidestand.
- Do not park on a lateral (sideways) incline of greater than 6° and never park facing downhill.
- Make sure that the side stand is fully retracted before riding off.
- Do not leave the switch in the P position for long periods of time as this will discharge the battery.

Note

When parking near traffic at night, or when parking in a location where parking lights are required by law, leave the tail, licence plate and position lights on by turning the ignition switch to P (PARK).

Considerations for High Speed Operation

Warning

This Triumph motorcycle should be operated within the legal speed limits for the particular road travelled.

Operating a motorcycle at high speeds can be potentially dangerous since the time available to react to given traffic situations is greatly reduced as road speed increases.

Always reduce speed in potentially hazardous driving conditions such as bad weather or heavy traffic.

Warning

Only operate this Triumph motorcycle at high speed in closed-course on-road competition or on closed-course racetracks.

High speed operation should only then be attempted by riders who have been instructed in the techniques necessary for high speed riding and are familiar with the motorcycle's characteristics in all conditions.

High speed operation in any other circumstances is dangerous and will lead to loss of motorcycle control and an accident.

How to Ride the Motorcycle

Warning

The handling characteristics of a motorcycle at high speed may vary from those you are familiar with at legal road speeds.

Do not attempt high speed operation unless you have received sufficient training and have the required skills as a serious accident may result from incorrect operation.

Warning

The items listed below are extremely important and must never be neglected. A problem, which may not be noticed at normal operating speeds, may be greatly exaggerated at high speeds.

General

Make sure that the motorcycle has been maintained according to the scheduled maintenance chart.

Brakes

Check that the front and rear brakes are functioning correctly.

Coolant

Check that the coolant level is at the upper level line in the expansion tank. Always check the level with the engine cold.

Electrical Equipment

Make sure that all electrical equipment such as the headlight, rear/brake light, direction indicators and horn all work correctly.

Engine Oil

Check that the engine oil level is correct. Make sure that the correct grade and type of oil is used when topping up.

Drive Chain

Make sure that the drive chain is correctly adjusted and lubricated. Inspect the chain for wear and damage.

Fuel

Have sufficient fuel for the increased fuel consumption that will result from high speed operation.

Caution

In many countries, the exhaust system for this model is fitted with a catalytic converter to help reduce exhaust emission levels.

The catalytic converter can be permanently damaged if the motorcycle is allowed to run out of fuel or if the fuel level is allowed to get very low.

Always make sure you have adequate fuel for your journey.

Luggage

Make sure that any luggage containers are closed, locked and securely fitted to the motorcycle.

Miscellaneous

Visually check that all fixings are tight.

Steering

Check that the handlebar turns smoothly without excessive free play or tight spots. Make sure that the control cables do not restrict the steering in any way.

Tyres

High speed operation is hard on tyres, and tyres that are in good condition are crucial to riding safely. Examine their overall condition, inflate to the correct pressure (when the tyres are cold), and check the wheel balance. Securely fit the valve caps after checking tyre pressures. Observe the information given in the maintenance and specification sections on tyre checking and tyre safety.

This page intentionally left blank

Accessories, Loading and Passengers

The addition of accessories and carriage of additional weight can affect the motorcycle's handling characteristics causing changes in stability and necessitating a reduction in speed. The following information has been prepared as a guide to the potential hazards of adding accessories to a motorcycle and carrying passengers and additional loads.

Accessories

Warning

Never ride an accessory equipped motorcycle, or a motorcycle carrying a payload of any kind, at speeds above 80 mph (130 km/h). In either/both of these conditions, speeds in excess of 80 mph (130 km/h) should not be attempted even where the legal speed limit permits this.

The presence of accessories and/or payload will cause changes in the stability and handling of the motorcycle.

Failure to allow for changes in motorcycle stability may lead to loss of motorcycle control and an accident. When riding at high speed, always be aware that various motorcycle configuration and environmental factors can adversely affect the stability of your motorcycle. For example:

- Incorrectly balanced loads on both sides of the motorcycle
- Incorrectly adjusted front and rear suspension settings
- Incorrectly adjusted tyre pressures
- Excessively or unevenly worn tyres
- Side winds and turbulence from other vehicles
- Loose clothing.

Accessories, Loading and Passengers

Warning

Remember that the 80 mph (130 km/h) absolute limit will be reduced by the fitting of non-approved accessories, incorrect loading, worn tyres, overall motorcycle condition and poor road or weather conditions.

Warning

Do not install accessories or carry luggage that impairs the control of the motorcycle.

Make sure that you have not adversely affected any lighting component, road clearance, banking capability (i.e. lean angle), control operation, wheel travel, front fork movement, visibility in any direction, or any other aspect of the motorcycle's operation.

Loading

The total weight of the rider, and any passenger, accessories and luggage must not exceed the maximum load limit of:

- Bonneville T100 - 210 kg (463 lb)
- Bonneville T120 - 210 kg (463 lb)
- Bonneville T120 Ace - 210 kg (463 lb)
- Bonneville T120 Diamond - 210 kg (463 lb)
- Speed Twin - 212 kg (467 lb)
- Street Scrambler - 223 kg (492 lb)
- Street Twin - 210 kg (463 lb)
- Thruxton - 210 kg (463 lb)
- Thruxton R - 210 kg (463 lb).

Warning

Incorrect loading may result in an unsafe riding condition leading to an accident.

Always make sure that any loads carried are evenly distributed on both sides of the motorcycle. Make sure that the load is correctly secured so that it will not move around while the motorcycle is in motion.

Evenly distribute the load within each pannier (if fitted). Pack heavy items at the bottom and on the inboard side of the pannier.

Always check the load security regularly (though not while the motorcycle is in motion) and make sure that the load does not extend beyond the rear of the motorcycle.

Never exceed the maximum vehicle loading weight listed above. This maximum loading weight is made up from the combined weight of the rider, passenger, any accessories fitted and any load carried.

This maximum loading weight is made up from the combined weight of the rider, passenger, any accessories fitted and any load carried.

For models that have adjustable suspension settings, make sure that front and rear spring preload and damping settings are suitable for the loading condition of the motorcycle (see page 129). Note the maximum permissible payload for the panniers is stated on a label inside the pannier.

Accessories, Loading and Passengers

Warning

If the passenger seat or luggage rack (if fitted) is used to carry small objects, they must not exceed a total maximum weight of:

Bonneville T120, Bonneville T120 Ace, Bonneville T120Diamond, Street Scrambler and Street Twin - 3 kg (6 lb)

Speed Twin, Thruxton and Thruxton R - 2 kg (4 lb).

This total weight (combined on the seat and luggage rack if fitted), must not impair control of the motorcycle, must be securely attached and must not extend beyond the rear or sides of the motorcycle.

Carriage of objects in excess of the above weights, that are insecure, impair control or extend beyond the rear or sides of the motorcycle may lead to loss of motorcycle control and an accident.

Even if small objects are correctly loaded onto the rear seat, the maximum speed of the motorcycle must be reduced to 80 mph (130 km/h).

Warning

Never attempt to store any items between the frame and the fuel tank. This can restrict the steering and will cause loss of control leading to an accident.

Weight attached to the handlebar or front fork will increase the mass of the steering assembly and can result in loss of steering control leading to an accident.

Passengers

Warning

Your passenger should be instructed that he or she can cause loss of motorcycle control by making sudden movements or by adopting an incorrect seated position.

The rider should instruct the passenger as follows:

It is important that the passenger sits still while the motorcycle is in motion and does not interfere with the operation of the motorcycle.

To keep his or her feet on the passenger footrests and to firmly hold onto the seat strap or the rider's waist or hips.

Advise the passenger to lean with the rider when travelling around corners and not to lean unless the rider does so.

Warning

Do not carry a passenger unless he or she is tall enough to reach the footrests provided.

A passenger who is not tall enough to reach the footrests will be unable to sit securely on the motorcycle and may cause instability leading to loss of control and an accident.

Accessories, Loading and Passengers

Warning

The handling and braking capabilities of a motorcycle will be affected by the presence of a passenger. The rider must make allowances for these changes when operating the motorcycle with a passenger and should not attempt such operation unless trained to do so and without becoming familiar and comfortable with the changes in motorcycle operating characteristics that this brings about.

Motorcycle operation without making allowances for the presence of a passenger could lead to loss of motorcycle control and an accident.

Warning

Do not carry animals on your motorcycle.

An animal could make sudden and unpredictable movements that could lead to loss of motorcycle control and an accident.

Maintenance and Adjustment

Table of Contents

Scheduled Maintenance	99
Scheduled Maintenance Table	101
Engine Oil	103
Engine Oil Level Inspection	103
Engine Oil and Oil Filter Change	104
Disposal of Used Engine Oil and Oil Filters	106
Engine Oil Specification and Grade	106
Cooling System	107
Coolant Level Inspection	107
Coolant Level Adjustment	109
Coolant Change	109
Throttle Control	110
Throttle Inspection	110
Clutch	111
Clutch Inspection	111
Clutch Adjustment	112
Drive Chain	113
Drive Chain Lubrication	113
Drive Chain Free Movement Inspection	114
Drive Chain Free Movement Adjustment	114
Drive Chain and Sprocket Wear Inspection	115
Brakes	117
Breaking-in New Brake Pads and Discs	117
Brake Pad Wear Compensation	118
Disc Brake Fluid	118
Front Brake Fluid Level Inspection and Adjustment	119
Rear Brake Fluid Level Inspection and Adjustment	121
Brake Light Switches	122
Mirrors	122
Steering/Wheel Bearings	124
Steering Inspection	124
Wheel Bearings Inspection	125

Maintenance and Adjustment

Front Suspension	126
Front Suspension Settings - Thruxton R	126
Front Suspension Preload Adjustment - Thruxton R Only	127
Front Suspension Rebound and Compression Damping Adjustment - Thruxton R Only	127
Front Fork Inspection	128
Rear Suspension	129
Rear Suspension Settings	129
Rear Suspension Preload Adjustment	129
Rear Suspension Rebound Damping Adjustment - Thruxton R Only	131
Rear Suspension Compression Damping Adjustment - Thruxton R Only	131
Bank Angle Indicators	132
Tyres	132
Tyre Inflation Pressures	133
Tyre Pressure Monitoring System (TPMS) (if fitted)	134
Tyre Wear	134
Minimum Recommended Tread Depth	135
Tyre Replacement	135
Battery	138
Battery Removal	138
Battery Disposal	139
Battery Maintenance	139
Battery Discharge	140
Battery Discharge During Storage and Infrequent Use of the Motorcycle	140
Battery Charging	140
Battery Installation	141
Fuses	142
Headlights	143
Headlight/Position Light Bulb Replacement	144
Headlight Adjustment	146
Rear Lights	146
Multifunctional Rear Lights (if fitted)	146
Direction Indicator Lights	147
License Plate Light	148

Scheduled Maintenance

Warning

Triumph Motorcycles cannot accept any responsibility for damage or injury resulting from incorrect maintenance or improper adjustment carried out by the owner.

Incorrect or neglected maintenance can lead to a dangerous riding condition.

Always have an authorised Triumph dealer carry out the scheduled maintenance of this motorcycle.

Warning

All maintenance is vitally important and must not be neglected. Incorrect maintenance or adjustment may cause one or more parts of the motorcycle to malfunction. A malfunctioning motorcycle may lead to loss of control and an accident.

Weather, terrain and geographical location affect maintenance. The maintenance schedule should be adjusted to match the particular environment in which the motorcycle is used and the demands of the individual owner.

Special tools, knowledge and training are required in order to correctly carry out the maintenance items listed in the scheduled maintenance chart. Only an authorised Triumph dealer will have this knowledge and equipment.

Incorrect or neglected maintenance can lead to a dangerous riding condition. Always have an authorised Triumph dealer carry out the scheduled maintenance of this motorcycle.

To maintain the motorcycle in a safe and reliable condition, the maintenance and adjustments outlined in this section must be carried out as specified in the schedule of daily checks, and also in line with the scheduled maintenance chart. The information that follows describes the procedures to follow when carrying out the daily checks and some simple maintenance and adjustment items.

Maintenance and Adjustment

Scheduled maintenance may be carried out by your authorised Triumph dealer in three ways; annual maintenance, mileage based maintenance or a combination of both, depending on the mileage the motorcycle travels each year.

1. Motorcycles travelling less than 10,000 miles (16,000 km) per year must be maintained annually. In addition to this, mileage based items require maintenance at their specified intervals, as the motorcycle reaches this mileage.
2. Motorcycles travelling approximately 10,000 miles (16,000 km) per year must have the annual maintenance and the specified mileage based items carried out together.
3. Motorcycles travelling more than 10,000 miles (16,000 km) per year must have the mileage based items maintained as the motorcycle reaches the specified mileage. In addition to this, annual based items will require maintenance at their specified annual intervals.

In all cases maintenance must be carried out at or before the specified maintenance intervals shown. Consult an authorised Triumph dealer for advice on which maintenance schedule is most suitable for your motorcycle.

Triumph Motorcycles cannot accept any responsibility for damage or injury resulting from incorrect maintenance or improper adjustment.

Service Symbol/General Warning Symbol

 The service symbol will illuminate for five seconds after the motorcycle start up sequence as a reminder that a service is due in approximately 60 miles (100 km). The service symbol will illuminate permanently when the mileage is reached, it will remain permanently illuminated until the service interval is reset using the Triumph Diagnostic tool.

 The general warning symbol will flash if an ABS or engine management fault has occurred and the ABS and/or MIL warning lights are illuminated. Contact an authorised Triumph dealer as soon as possible to have the fault checked and rectified.

Maintenance and Adjustment

Scheduled Maintenance Table

Operation Description	Odometer Reading in Miles (Km) or Time Period, whichever comes first					
		First Service	Annual Service	Mileage Based Service		
	Every	500 (800) 1 month	Year	10,000 and 30,000 (16,000 and 48,000)	20,000 (32,000)	40,000 (64,000)
Lubrication						
Engine - check for leaks	Day	*	*	*	*	*
Engine oil - renew	-	*	*	*	*	*
Engine oil filter - renew	-	*	*	*	*	*
Fuel System and Engine Management						
Fuel system - check for leaks, chafing etc.	-			*	*	*
Throttle body plate (butterfly) - check/clean	-			*	*	*
Autoscan - Carry out a full Autoscan using the Triumph Diagnostic Tool (print a customer copy)	-	*	*	*	*	*
Air cleaner - renew	-			*	*	*
Fuel filter - renew	-				*	*
Throttle bodies - balance - 1200 cc engines only	-			*	*	*
Fuel hoses - renew	Every 4 years regardless of mileage					
Evaporative loss hoses* - renew	Every 4 years regardless of mileage					
Ignition System						
Spark plugs - check	-			*		
Spark plugs - renew	-				*	*
Cooling System						
Cooling system - check for leaks	Day	*	*	*	*	*
Cooling system - check hoses for chafing/cracks/damage. Replace if necessary	-			*	*	*
Coolant level - check/adjust	Day	*	*	*	*	*
Coolant - renew	Every 3 years regardless of mileage					
Engine						
Clutch cable - check function and adjust as necessary	Day	*	*	*	*	*
Valve clearances - check	-				*	*
Camshaft timing	-				*	*
Wheels and Tyres						
Tyre wear/tyre damage - check	Day	*	*	*	*	*
Tyre pressures - check/adjust	Day	*	*	*	*	*
Wheels - inspect for damage	Day	*	*	*	*	*
Wheels - check wheels for broken or damaged spokes and check spoke tightness (models with spoked wheels only)	Day	*	*	*	*	*
Wheel bearings - check for wear/smooth operation	-	*	*	*	*	*

Maintenance and Adjustment

Operation Description	Odometer Reading in Miles (Km) or Time Period, whichever comes first					
		First Service	Annual Service	Mileage Based Service		
	Every	500 (800) 1 month	Year	10,000 and 30,000 (16,000 and 48,000)	20,000 (32,000)	40,000 (64,000)
Steering and Suspension						
Steering - check for free operation	Day	*	*	*	*	*
Front and rear suspension - check for damage/leaks/smooth operation	Day	*	*	*	*	*
Fork oil - renew	-					*
Headstock bearings - check/adjust	-	*	*	*	*	*
Headstock bearings - lubricate	-				*	*
Brakes						
Brake pads - check wear levels	Day	*	*	*	*	*
Brake master cylinders - check for fluid leaks	-	*	*	*	*	*
Brake calipers - check for fluid leaks and seized pistons	-	*	*	*	*	*
Brake fluid levels - check	Day	*	*	*	*	*
Brake fluid - renew	Every 2 years regardless of mileage					
Drive Chain						
Drive chain slack - check/adjust	Day	*	*	*	*	*
Drive chain - wear check	Every 500 miles (800 km)					
Drive chain - lubricate	Every 200 miles (300 km)					
Drive chain rubbing strip - check	-	*	*	*	*	*
Electrical						
All lights, instruments and electrical systems - check	Day	*	*	*	*	*
General						
Instruments and engine ECM - check for latest calibration download using the Triumph diagnostic tool	-	*	*	*	*	*
Fasteners - inspect visually for security	Day	*	*	*	*	*
Bank angle indicators - inspect visually for wear	Day	*	*	*	*	*
Side stand/Centre stand - lubricate/check operation	Day	*	*	*	*	*
Side stand pivot pin - clean/grease	-			*	*	*
Carry out all outstanding Service Bulletin and warranty work	-	*	*	*	*	*
Carry out road test	-	*	*	*	*	*
Complete the service record book and reset the service indicator (if fitted)	-	*	*	*	*	*
* Evaporative system fitted to models for certain markets only.						

Engine Oil



Warning

Motorcycle operation with insufficient, deteriorated, or contaminated engine oil will cause accelerated engine wear and may result in engine or transmission seizure.

Seizure of the engine or transmission may lead to sudden loss of control and an accident.

In order for the engine, transmission, and clutch to function correctly, maintain the engine oil at the correct level, and change the engine oil and oil filter in accordance with scheduled maintenance requirements.

Engine Oil Level Inspection

Warning

Never start the engine or run the engine in a confined area.

Exhaust fumes are poisonous and can cause loss of consciousness and death within a short period of time.

Always operate the motorcycle in the open air or in an area with adequate ventilation.

Warning

If the engine has recently been running, the exhaust system will be hot.

Before working on or near the exhaust system, allow sufficient time for the exhaust system to cool as touching any part of a hot exhaust system could cause burn injuries.

Caution

Running the engine with insufficient oil will cause engine damage.

If the low oil pressure indicator remains on, stop the engine immediately and investigate the situation.

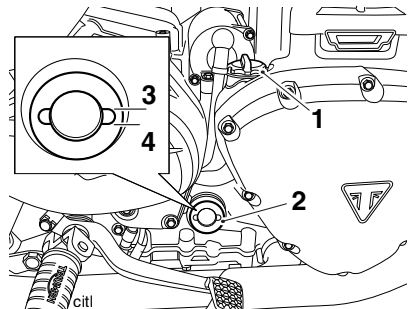

1. Filler plug
2. Sight glass
3. Maximum limit
4. Minimum limit

Maintenance and Adjustment

To inspect the engine oil level:

- Start the engine and run at idle for approximately five minutes. Stop the engine and wait for at least three minutes to allow the engine oil to settle.
- Note the engine oil level visible in the sight glass.
- When correct, engine oil should be visible in the sight glass at a point midway between the upper (maximum) and lower (minimum) markings on the sight glass.

Note

An accurate indication of the level of engine oil in the engine is only shown when the engine is at normal operating temperature and the motorcycle is upright (not on the side stand).

- If it is necessary to top up the engine oil level, remove the filler plug and add engine oil, a little at a time, until the level registered in the sight glass is correct.

Caution

Make sure no foreign matter or contamination enters the engine during an engine oil change or top up. Contamination entering the engine may lead to engine damage.

- Once the correct level is reached, fit and tighten the filler plug.

Engine Oil and Oil Filter Change

Warning

Prolonged or repeated contact with engine oil can lead to skin dryness, irritation and dermatitis.

Used engine oil contains harmful contamination that can lead to skin cancer.

Always wear suitable protective clothing and avoid skin contact with used oil.

Warning

The oil may be hot to the touch.

Avoid contact with the hot oil by wearing suitable protective clothing, gloves, eye protection, etc.

Contact with hot oil may cause the skin to be scalded or burned.

Warning

If the engine has recently been running, the exhaust system will be hot.

Before working on or near the exhaust system, allow sufficient time for the exhaust system to cool as touching any part of a hot exhaust system could cause burn injuries.

The engine oil and filter must be renewed in accordance with scheduled maintenance requirements.

Maintenance and Adjustment

To change the engine oil and filter:

- Warm up the engine thoroughly then stop the engine. Secure the motorcycle on the side stand.
- Allow the engine oil to settle for five minutes before draining.
- Place an oil drain pan beneath the engine.
- Remove the sump plug from the bottom of the sump and allow the engine oil to drain.

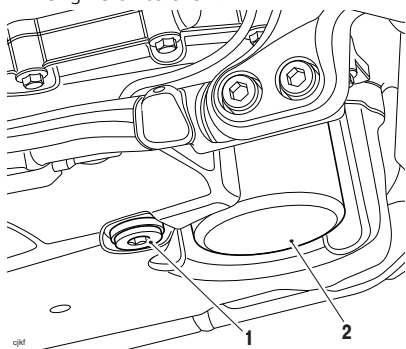

1. Sump plug
2. Engine oil filter

- Remove the sump plug from the bottom of the sump and allow the engine oil to drain.
 - Secure the motorcycle in an upright position on level ground.
 - Position the oil drain pan beneath the engine oil filter.
 - Unscrew and remove the engine oil filter using the Triumph service tool T3880313. Dispose of the old filter in an environmentally friendly way.
 - Prefill the replacement engine oil filter with new engine oil.
- Apply a smear of clean engine oil to the sealing ring of the new engine oil filter. Fit the engine oil filter and tighten to 10 Nm.
 - After the engine oil has completely drained out, fit a new sealing washer to the sump plug. Fit and tighten the plug to 25 Nm.
 - Remove the engine oil filler plug.
 - Using a suitable funnel, fill the engine with a 10W/40 or 10W/50 semi or fully synthetic motorcycle engine oil that meets specification API SH (or higher) and JASO MA, such as Castrol Power 1 Racing 4T 10W-40 (fully synthetic) engine oil, sold as Castrol Power RS Racing 4T 10W-40 (fully synthetic) in some countries.
 - Do not overfill or exceed the capacities given in the Specifications section.
 - Start the engine and allow it to idle for a minimum of 30 seconds.

Caution

Raising the engine speed above idle, before the engine oil reaches all parts of the engine can cause engine damage or seizure.

Only raise engine speed after running the engine for 30 seconds to allow the engine oil to circulate fully.

- Make sure that the low oil pressure warning light extinguishes shortly after starting.

Maintenance and Adjustment

Caution

If the engine oil pressure is too low, the low oil pressure warning light will illuminate. If this light stays on when the engine is running, stop the engine immediately and investigate the cause.

Running the engine with low oil pressure will cause engine damage.

- Turn the ignition OFF, check the engine oil level using the method previously described, and top up to between the minimum and maximum level lines in the sight glass.

Disposal of Used Engine Oil and Oil Filters

To protect the environment, do not pour oil on the ground, down sewers or drains, or into watercourses. Do not place used oil filters in with general waste. If in doubt, contact your local authority.

Engine Oil Specification and Grade

Triumph's high performance fuel injected engines are designed to use 10W/40 or 10W/50 semi or fully synthetic motorcycle engine oil that meets specification API SH (or higher) and JASO MA, such as Castrol Power 1 Racing 4T 10W-40 (fully synthetic) engine oil, sold as Castrol Power RS Racing 4T 10W-40 (fully synthetic) in some countries.

Refer to the chart below for the correct oil viscosity (10W/40 or 10W/50) to be used in your riding area.

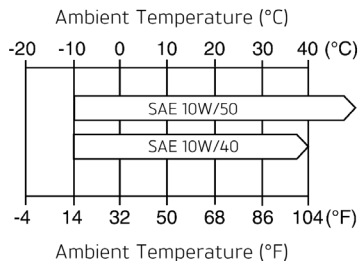

Oil Viscosity Temperature Range

Do not add any chemical additives to the engine oil. The engine oil also lubricates the clutch and any additives could cause the clutch to slip.

Do not use mineral, vegetable, non-detergent oil, castor based oils or any oil not conforming to the required specification. The use of these oils may cause instant, severe engine damage.

Make sure that no foreign matter enters the crankcase during an engine oil change or top up.

Cooling System



To ensure efficient engine cooling, check the coolant level each day before riding the motorcycle, and top up the coolant if the level is low.

Note

A year round, Hybrid Organic Acid Technology (known as Hybrid OAT or HOAT) coolant is installed in the cooling system when the motorcycle leaves the factory. It is coloured green, contains a 50% solution of ethylene glycol based antifreeze, and has a freezing point of -35°C (-31°F).

Corrosion Inhibitors

Warning

HD4X Hybrid OAT coolant contains corrosion inhibitors and antifreeze suitable for aluminium engines and radiators. Always use the coolant in accordance with the instructions of the manufacturer.

Coolant that contains anti-freeze and corrosion inhibitors contains toxic chemicals that are harmful to the human body. Never swallow antifreeze or any of the motorcycle coolant.

Note

HD4X Hybrid OAT coolant, as supplied by Triumph, is premixed and does not need to be diluted prior to filling or topping up the cooling system.

To protect the cooling system from corrosion, the use of corrosion inhibitor chemicals in the coolant is essential.

If coolant containing a corrosion inhibitor is not used, the cooling system will accumulate rust and scale in the water jacket and radiator. This will block the coolant passages, and considerably reduce the efficiency of the cooling system.

Coolant Level Inspection

Note

The coolant level should be checked when the engine is cold (at room or ambient temperature).

Bonneville T100, Bonneville T120, Bonneville T120 Ace, Bonneville T120 Diamond and Street Twin

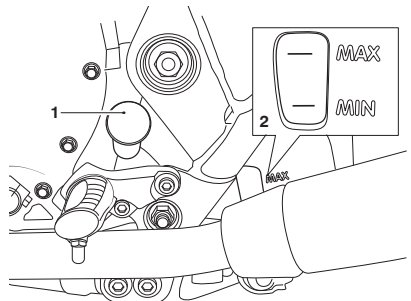

1. Expansion tank cap
2. MAX and MIN marks

Maintenance and Adjustment

To inspect the coolant level:

- Position the motorcycle on level ground and in an upright position. The expansion tank can be viewed from the left hand side of the motorcycle, towards the rear of the engine.
- Check the coolant level in the expansion tank. The coolant level must be between the MAX and MIN marks. If the coolant is below the minimum level, the coolant level must be adjusted.

Street Scrambler

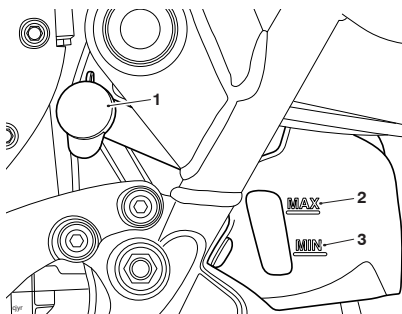

1. Expansion tank cap
2. MAX mark
3. MIN mark

To inspect the coolant level:

- Position the motorcycle on level ground and in an upright position. The expansion tank can be viewed from the left hand side of the motorcycle, towards the rear of the engine.
- Check the coolant level in the expansion tank. The coolant level must be between the MAX and MIN marks. If the coolant is below the minimum level, the coolant level must be adjusted.

Speed Twin, Thruxton and Thruxton R

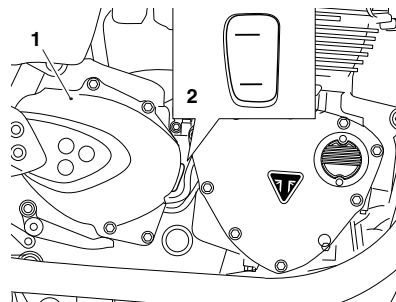

1. Expansion tank cap
2. MAX and MIN marks

To inspect the coolant level:

- Position the motorcycle on level ground and in an upright position. The expansion tank can be viewed from the right hand side of the motorcycle, towards the rear of the engine.
- Check the coolant level in the expansion tank. The coolant level must be between the maximum (top) and minimum (bottom) marks. If the coolant is below the minimum level, the coolant level must be adjusted.

Coolant Level Adjustment

Warning

Do not remove the expansion tank or radiator pressure cap when the engine is hot.

When the engine is hot, the coolant inside the radiator will be hot and also under pressure.

Contact with this hot, pressurised coolant will cause scalds and skin damage.

Caution

If hard water is used in the cooling system, it will cause scale accumulation in the engine and radiator and considerably reduce the efficiency of the cooling system.

Reduced cooling system efficiency may cause the engine to overheat and suffer severe damage.

Note

If the coolant level is being checked because the coolant has overheated, also check the level in the radiator and top up if necessary.

In an emergency, distilled water can be added to the cooling system. However, the coolant must then be drained and replenished with HD4X Hybrid OAT coolant as soon as possible.

Bonneville T100, Bonneville T120, Bonneville T120 Ace, Bonneville T120 Diamond, Street Scrambler and Street Twin

To adjust the coolant level:

- Allow the engine to cool.
- The expansion tank cap can be removed from the left hand side of the motorcycle, towards the rear of the engine.
- Remove the cap from the expansion tank and add coolant mixture through the filler opening until the level reaches the MAX mark. Refit the cap.

Speed Twin, Thruxton and Thruxton R

To adjust the coolant level:

- The expansion tank cap can be removed from the right hand side of the motorcycle, towards the rear of the engine.
- Remove the sprocket cover.
- Remove the cap from the expansion tank and add coolant mixture through the filler opening until the level reaches the maximum (top) mark.
- Refit the cap. Refit the sprocket cover to 9 Nm.

Coolant Change

It is recommended that the coolant is changed by an authorised Triumph dealer in accordance with scheduled maintenance requirements.

Maintenance and Adjustment

Radiator and Hoses

Warning

The fan operates automatically when the engine is running.

Always keep hands and clothing away from the fan.

Contact with the rotating fan may cause an accident and/or personal injury.

Caution

Using high pressure water sprays, such as from a car wash facility or household pressure washer, can damage the radiator fins, cause leaks and impair the radiator's efficiency.

Do not obstruct or deflect airflow through the radiator by installing unauthorised accessories, either in front of the radiator or behind the cooling fan.

Interference with the radiator airflow can cause overheating, potentially resulting in engine damage.

Check the radiator hoses for cracks or deterioration, and tension clips for tightness in accordance with scheduled maintenance requirements. Have your authorised Triumph dealer replace any defective items.

Check the radiator grille and fins for obstructions by insects, leaves or mud. Clean off any obstructions with a stream of low pressure water.

Throttle Control

Warning

Always be alert for changes in the 'feel' of the throttle control and have the throttle system checked by an authorised Triumph dealer if any changes are detected.

Changes can be due to wear in the mechanism, which could lead to a sticking throttle control.

A sticking or stuck throttle control will lead to loss of motorcycle control and an accident.

Throttle Inspection

Warning

Use of the motorcycle with a sticking or damaged throttle control will interfere with the throttle function resulting in loss of motorcycle control and an accident.

To avoid continued use of a sticking or damaged throttle control, always have it checked by your authorised Triumph dealer.

To inspect the throttle:

- Check that the throttle opens smoothly, without undue force and that it closes without sticking. Have your authorised Triumph dealer check the throttle system if a problem is detected or any doubt exists.

Maintenance and Adjustment

- If there is an incorrect amount of free play, Triumph recommends that you have your authorised Triumph dealer investigate.
- Check that there is 1-2 mm of throttle grip free play when lightly turning the throttle grip back and forth.

Clutch

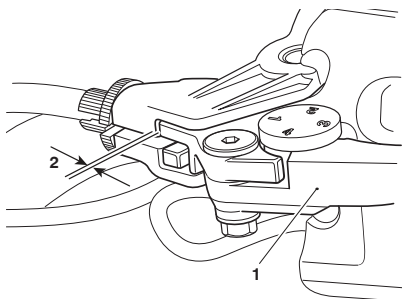

1. Clutch lever
2. 2 - 3 mm

The motorcycle is equipped with a cable-operated clutch.

If the clutch lever has excessive free play, the clutch may not disengage fully. This will cause difficulty in changing gear and selecting neutral. This may cause the engine to stall and make the motorcycle difficult to control.

Conversely, if the clutch lever has insufficient free play the clutch may not engage fully, causing the clutch to slip, which will reduce performance and cause premature clutch wear.

Clutch lever free play must be checked in accordance with scheduled maintenance requirements.

Clutch Inspection

Check that there is 2-3 mm clutch lever free play at the lever.

If there is an incorrect amount of free play, adjustments must be made.

Maintenance and Adjustment

Clutch Adjustment

To adjust the clutch:

- Turn the adjuster sleeve until the correct amount of clutch lever free play is achieved.
- Check that there is 2 - 3 mm clutch lever free play at the lever.
- If there is an incorrect amount of free play, adjustments must be made.

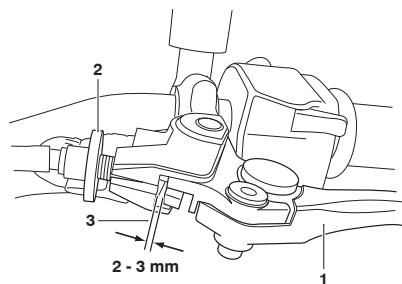

1. Clutch lever
2. Adjuster sleeve (locknut fully released)
3. Correct clearance 2-3 mm

If correct adjustment cannot be made using the lever adjuster, use the cable adjuster at the lower end of the cable.

- Loosen the adjuster lock nut.
- Turn the outer cable adjuster to give 2 - 3 mm of free play at the clutch lever.
- Tighten the lock nut to 3.5 Nm.

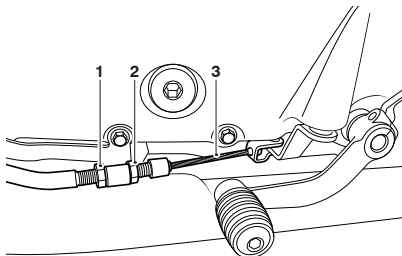

1. Adjuster nut
2. Lock nut
3. Clutch cable

Drive Chain



Warning

A loose or worn chain, or a chain that breaks or jumps off the sprockets could catch on the engine sprocket or lock the rear wheel.

A chain that snags on the engine sprocket will injure the rider and lead to loss of motorcycle control and an accident.

Similarly, locking the rear wheel will lead to loss of motorcycle control and an accident.

For safety and to prevent excessive wear the drive chain must be checked, adjusted and lubricated in accordance with the scheduled maintenance requirements. Checking, adjustment and lubrication must be carried out more frequently for extreme conditions such as high speed riding, salty or heavily gritted roads.

If the chain is badly worn or incorrectly adjusted (either too loose or too tight) the chain could jump off the sprockets or break. Therefore, always replace worn or damaged chains using genuine Triumph parts supplied by an authorised Triumph dealer.

Drive Chain Lubrication

Lubrication is necessary every 200 miles (300 km) and also after riding in wet weather, on wet roads, or any time that the chain appears dry.

To lubricate the drive chain:

- Use the special drive chain lubricant as recommended in the Specifications section.
- Apply lubricant to the sides of the rollers then allow the motorcycle to stand unused for at least eight hours (overnight is ideal). This will allow the oil to penetrate to the drive chain O-rings etc.
- Before riding, wipe off any excess oil.
- If the drive chain is especially dirty, clean first and then apply oil as mentioned above.

Caution

Do not use a pressure washer to clean the drive chain as this may cause damage to the drive chain components.

Maintenance and Adjustment

Drive Chain Free Movement Inspection

Warning

Before starting work, make sure the motorcycle is stabilised and adequately supported.

This will help prevent injury to the operator or damage to the motorcycle.

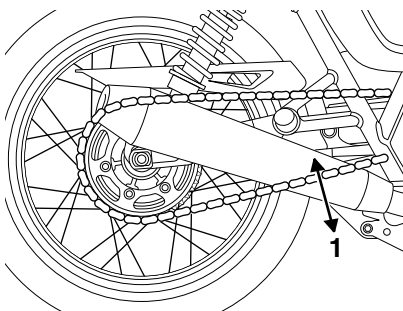

1. Maximum movement position

To inspect the drive chain movement:

- Place the motorcycle on a level surface and hold it in an upright position with no weight on it.
- Rotate the rear wheel by pushing the motorcycle to find the position where the drive chain is tightest, and measure the vertical movement of the drive chain midway between the sprockets.

Drive Chain Free Movement Adjustment

The vertical movement of the drive chain must be in the range 20 - 30 mm.

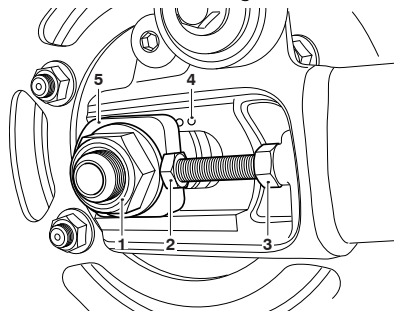

1. Rear wheel spindle nut
2. Adjuster bolt
3. Adjuster bolt lock nut
4. Adjuster markings
5. Spindle adjuster

If the drive chain free movement measurement is incorrect, adjustments must be made as follows:

- Loosen the wheel spindle nut.
- Loosen the lock nuts on both the left hand and right hand drive chain adjuster bolts.
- Move both adjusters by an equal amount using the adjuster markings as a guideline.
- Turn the adjuster bolts clockwise to increase drive chain free movement and anticlockwise to reduce drive chain free movement.
- When the correct amount of drive chain free movement has been set, push the wheel into firm contact with the adjusters.

Maintenance and Adjustment

- Make sure the same adjuster marking is aligned with the spindle adjuster on both sides of the swinging arm.
- Tighten both adjuster lock nuts to 20 Nm and the rear wheel spindle nut to 110 Nm.
- Repeat the drive chain adjustment check. Readjust if necessary.

⚠ Warning

Operation of the motorcycle with insecure adjuster lock nuts or a loose wheel spindle may result in impaired stability and handling of the motorcycle.

This impaired stability and handling may lead to loss of control or an accident.

- Check the rear brake effectiveness. Rectify if necessary.

⚠ Warning

It is dangerous to operate the motorcycle with defective brakes; you must have your authorised Triumph dealer take remedial action before you attempt to ride the motorcycle again.

Failure to take remedial action may reduce braking efficiency leading to loss of motorcycle control or an accident.

Drive Chain and Sprocket Wear Inspection

⚠ Warning

Never neglect drive chain maintenance and always have drive chains installed by an authorised Triumph dealer.

Use a genuine Triumph supplied drive chain as specified in the Triumph Parts Catalogue.

The use of non-approved drive chains may result in a broken drive chain or may cause the drive chain to jump off the sprockets leading to loss of motorcycle control or an accident.

⚠ Caution

If the sprockets are found to be worn, always replace the sprockets and drive chain together.

Replacing worn sprockets without also replacing the drive chain will lead to premature wear of the new sprockets.

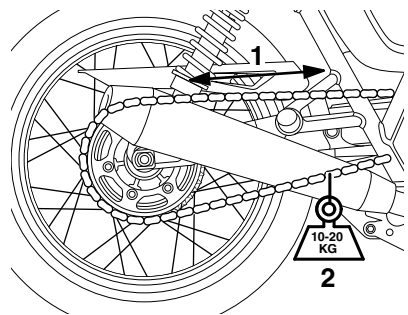

1. Measure across 20 links
2. Weight

Maintenance and Adjustment

To inspect the drive chain and sprocket wear:

- Remove the drive chain guard.
- Stretch the drive chain taut by hanging a 10 - 20 kg (20 - 40 lb) weight on the drive chain.
- Measure the length of 20 links on the straight part of the drive chain from pin centre of the 1st pin to the pin centre of the 21st pin. Since the drive chain may wear unevenly, take measurements in several places.
- If the length exceeds the maximum service limit of 320 mm, the drive chain must be replaced.
- Rotate the rear wheel and inspect the drive chain for damaged rollers, and loose pins and links.
- Also inspect the sprockets for unevenly or excessively worn or damaged teeth.

Note

Illustration shows wear on sprockets mounted on the left hand side of the motorcycle.

For sprockets mounted on the right hand side of the motorcycle, the wear is on the opposite side of the tooth.

- If there is any irregularity, have the drive chain and/or the sprockets replaced by an authorised Triumph dealer.
- Refit the drive chain guard and tighten the fixings to 9 Nm.

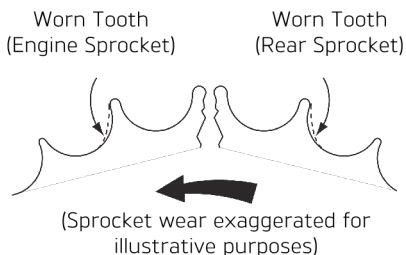

ccol

Brakes

Warning

Always replace all of the brake pads in the brake caliper. Do not replace individual brake pads.

Replacing individual brake pads will reduce braking efficiency and may cause loss of motorcycle control and an accident.

Brake pads must be inspected in accordance with scheduled maintenance requirements and replaced if worn to, or beyond the minimum service thickness.

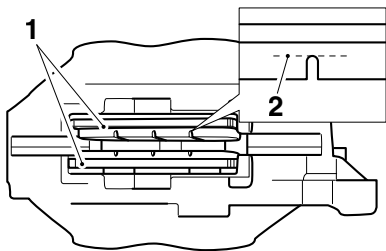

cbmz_2

1. Brake pads
2. Minimum thickness line

Bonneville T100, Bonneville T120, Bonneville T120 Ace, Bonneville T120 Diamond and Thruxton

If the lining thickness of any brake pad (front or rear brakes) is less than 1.5 mm (0.06 in), that is, if the brake pad has worn down to the bottom of the grooves, replace all the brake pads on that wheel.

Street Scrambler, Speed Twin, Street Twin and Thruxton R

If the lining thickness of any brake pad is less than 1.0 mm (0.04 in) (front) or 1.5 mm (0.06 in) (rear), replace all the brake pads on that wheel.

Note

Street Scrambler, Speed Twin and Street Twin Only

An area of the front brake backing plate is raised and will cause the front brake to squeal as notification to the rider when the brake pad(s) are below the minimum thickness. Replace all the brake pads on that wheel.

Breaking-in New Brake Pads and Discs

Warning

Brake pads must always be replaced as a wheel set. At the front, where two calipers are fitted on the same wheel, replace all the brake pads in both calipers.

Replacing individual pads will reduce braking efficiency and may cause an accident.

After replacement brake pads have been fitted, ride with extreme caution until the new pads have 'broken in'.

New brake discs and pads require a period of careful breaking-in that will optimise the performance and longevity of the discs and pads. The recommended distance for breaking-in new pads and discs is 200 miles (300 km).

Maintenance and Adjustment

During this period, avoid extreme braking, ride with caution and allow for greater braking distances.

Brake Pad Wear Compensation

Warning

If the brake lever or pedal feels soft when it is applied, or if the lever/pedal travel becomes excessive, there may be air in the brake pipes and hoses or the brakes may be defective.

It is dangerous to operate the motorcycle under such conditions and your authorised Triumph dealer must rectify the fault before riding.

Riding with defective brakes may lead to loss of motorcycle control and an accident.

Disc and brake pad wear is automatically compensated for and has no effect on the brake lever or pedal action. There are no parts that require adjustment on the front and rear brakes.

Disc Brake Fluid

Warning

Brake fluid is hygroscopic which means it will absorb moisture from the air.

Any absorbed moisture will greatly reduce the boiling point of the brake fluid causing a reduction in braking efficiency.

Because of this, always replace brake fluid in accordance with scheduled maintenance requirements.

Always use new brake fluid from a sealed container and never use fluid from an unsealed container or from one which has been previously opened.

Do not mix different brands or grades of brake fluid.

Check for fluid leakage around brake fittings, seals and joints and also check the brake hoses for splits, deterioration and damage.

Always rectify any faults before riding.

Failure to observe and act upon any of these items may cause a dangerous riding condition leading to loss of control and an accident.

Warning

If the ABS is not functioning, the brake system will continue to function as a non-ABS equipped brake system.

In this situation, braking too hard will cause the wheels to lock resulting in loss of control and an accident.

Reduce speed and do not continue to ride for longer than is necessary with the indicator light illuminated. Contact an authorised Triumph dealer as soon as possible to have the fault checked and rectified.

Inspect the level of brake fluid in both reservoirs and change the brake fluid in accordance with scheduled maintenance requirements. Use only DOT 4 fluid as recommended in the Specification section. The brake fluid must also be changed if it becomes, or is suspected of having become contaminated with moisture or any other contaminants.

Note

A special tool is required to bleed the ABS braking system. Contact your authorised Triumph dealer when the brake fluid needs renewing or the hydraulic system requires maintenance.

Front Brake Fluid Level Inspection and Adjustment

Inspect and adjust the brake fluid level as described below.

Street Scrambler and Street Twin

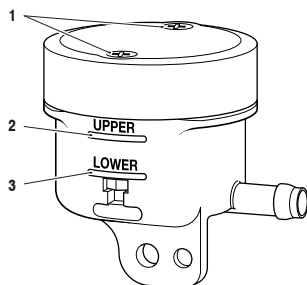

1. Cap retaining screws
2. Upper level line
3. Lower level line

The brake fluid level in the reservoirs must be kept between the upper and lower level lines (reservoir held horizontal).

To adjust the brake fluid level:

- Release the cap retaining screws and remove the reservoir cap and the diaphragm seal.
- Fill the reservoir to the upper level line using new DOT 4 from a sealed container.
- Refit the reservoir cap making sure that the diaphragm seal is correctly positioned between the cap and the reservoir body.
- Tighten the cap retaining screws to 1 Nm.

Maintenance and Adjustment

Speed Twin and Thruxton R

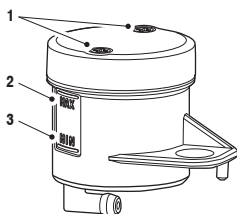

img_3

1. Reservoir cap retaining screws
2. MAX level line
3. MIN level line

The brake fluid level in the reservoir must be kept between the MAX and MIN level lines (reservoir held horizontal).

To adjust the brake fluid level:

- Release the reservoir cap retaining screws and remove the reservoir cap and the diaphragm seal.
- Fill the reservoir to the MAX level line using new DOT 4 fluid from a sealed container.
- Refit the reservoir cap making sure that the diaphragm seal is correctly positioned between the reservoir cap and reservoir body.
- Tighten the reservoir cap retaining screws to 1 Nm.

Bonneville T100, Bonneville T120, Bonneville T120 Ace, Bonneville T120 Diamond and Thruxton

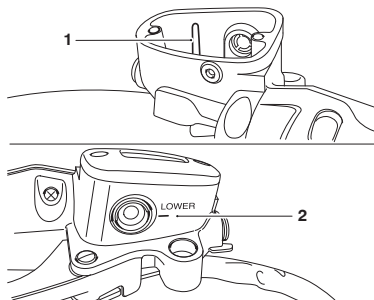

1. Upper level line
2. Lower level line

To inspect the front brake fluid level:

- Check the level of fluid visible in the window at the front of the reservoir body.
- The brake fluid level must be kept between the upper and lower level lines (reservoir held horizontal).

To adjust the brake fluid level:

- Release the cap retaining screws and remove the reservoir cap and the diaphragm seal.
- Fill the reservoir to the upper level line using new DOT 4 brake fluid from a sealed container.
- Refit the reservoir cap making sure that the diaphragm seal is correctly positioned between the cap and reservoir body.
- Tighten the cap retaining screws to 1 Nm.

Rear Brake Fluid Level Inspection and Adjustment

Warning

If there has been an appreciable drop in the level of the fluid in either fluid reservoir, consult your authorised Triumph dealer for advice before riding.

Riding with depleted brake fluid levels, or with a brake fluid leak is dangerous and will cause reduced brake performance potentially leading to loss of motorcycle control and an accident.

All Models except Street Scrambler

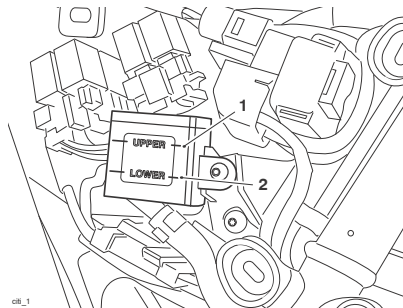

1. Upper level line
2. Lower level line

To inspect the rear brake fluid level:

- Remove the right hand side panel as described on page 68.
- The brake fluid level in the rear reservoir must be kept between the upper and lower level lines.

To adjust the rear brake fluid level:

- Release the reservoir from the airbox without detaching the connecting hose.

- Release the cap retaining screws and remove the cap noting the position of the sealing diaphragm.
- Fill the reservoir to the upper level line using new DOT 4 from a sealed container.
- Refit the reservoir cap making sure that the diaphragm seal is correctly positioned between the cap and the reservoir body.
- Tighten the cap retaining screws to 1.5 Nm.
- Refit the reservoir to the airbox by tightening the original fixing to 5 Nm.
- Refit the right hand side panel.

Street Scrambler

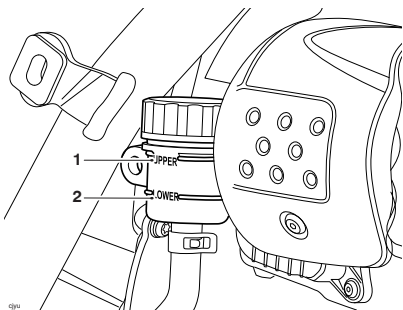

1. Upper level line
2. Lower level line

To inspect the rear brake fluid level:

- Remove the right hand side panel as described for the Street Scrambler on page 69.
- The brake fluid level in the rear reservoir must be kept between the upper and lower level lines.

Maintenance and Adjustment

To adjust the rear brake fluid level:

- Release the reservoir from the frame without detaching the connecting hose.
- Remove the cap noting the position of the sealing diaphragm.
- Fill the reservoir to the upper level line using new DOT 4 from a sealed container.
- Refit the reservoir cap making sure that the diaphragm seal is correctly positioned between the cap and the reservoir body.
- Refit the reservoir to the frame by tightening the original fixing to 5 Nm.
- Refit the right hand side panel.

Brake Light Switches

Warning

Riding the motorcycle with defective brake lights is illegal and dangerous.

An accident causing injury to the rider and other road users may result from use of a motorcycle with defective brake lights.

The brake light is activated independently by either the front or rear brake. If, with the ignition in the ON position, the brake light does not work when the front brake lever is pulled or the rear brake pedal is pressed, have your authorised Triumph dealer investigate and rectify the fault.

Mirrors

Warning

Operation of the motorcycle with incorrectly adjusted mirrors is dangerous.

Operation of the motorcycle with incorrectly adjusted mirrors will result in loss of vision to the rear of the motorcycle. It is dangerous to ride a motorcycle without sufficient rearward vision.

Always adjust the mirrors to provide sufficient rearward vision before riding the motorcycle.

Warning

Never attempt to clean or adjust mirrors while riding the motorcycle. Removal of the rider's hands from the handlebars while riding the motorcycle will diminish the ability of the rider to maintain control of the motorcycle.

Attempting to clean or adjust mirrors while riding the motorcycle may result in loss of control of the motorcycle and an accident.

Only attempt to clean or adjust the mirrors while stationary.

Models with Bar End Mirrors

Warning

Incorrect adjustment of the bar end mirrors may cause the mirror arm to contact the fuel tank, brake or clutch levers or other parts of the motorcycle.

This will restrict brake or clutch lever operation or restrict steering movement, resulting in loss of motorcycle control and an accident.

Adjust the mirrors as required to make sure they do not contact any part of the motorcycle. After adjustment, move the handlebar to the left and right full lock while checking that the mirrors do not contact the fuel tank, brake or clutch levers or other parts of the motorcycle.

The bar end mirrors will be set by your authorised Triumph dealer and will not normally require any adjustment. Should adjustment be necessary, do not rotate the mirror beyond 75°, measured from the vertical section of the mirror arm.

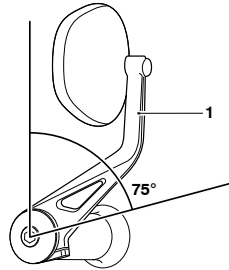

1. Mirror arm vertical section

Caution

Incorrect adjustment of the bar end mirrors may cause the mirror arm to contact the fuel tank, brake or clutch levers or other parts of the motorcycle.

This will result in damage to the fuel tank, brake or clutch levers or other parts of the motorcycle.

Adjust the mirrors as required to make sure they do not contact any part of the motorcycle. After adjustment, move the handlebar to the left and right full lock while checking that the mirrors do not contact the fuel tank, brake or clutch levers or other parts of the motorcycle.

Maintenance and Adjustment

Steering/Wheel Bearings

Warning

To prevent risk of injury from the motorcycle falling during the inspection, make sure that the motorcycle is stabilised and secured on a suitable support.

Do not exert extreme force against each wheel or rock each wheel vigorously as this may cause the motorcycle to become unstable and cause injury by falling from its support.

Make sure that the position of the support block will not cause damage to the motorcycle.

Steering Inspection

Warning

Riding the motorcycle with incorrectly adjusted or defective steering (headstock) bearings is dangerous and may cause loss of motorcycle control and an accident.

The steering (headstock) bearings must be lubricated and inspected in accordance with scheduled maintenance requirements. Always inspect the wheel bearings at the same time as the steering bearings.

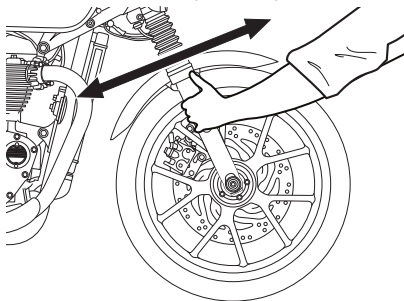

Inspecting the Steering for Free Play

To inspect the steering:

- Position the motorcycle on level ground, in an upright position.
- Raise the front wheel above the ground and support the motorcycle.
- Standing at the front of the motorcycle, hold the lower end of the front forks and try to move them forward and backward.
- If any free play can be detected in the steering (headstock) bearings, ask your authorised Triumph dealer to inspect and rectify any faults before riding.
- Remove the support and place the motorcycle on the side stand.

Wheel Bearings Inspection

Warning

Riding with worn or damaged front or rear wheel bearings is dangerous and may cause impaired handling and instability leading to an accident.

If in doubt, have the motorcycle inspected by an authorised Triumph dealer before riding.

- Reposition the lifting device and repeat the procedure for the rear wheel.
- Remove the support and place the motorcycle on the side stand.

Note

If the wheel bearings in the front or rear wheel allow play in the wheel hub, are noisy, or if the wheel does not turn smoothly, have your authorised Triumph dealer inspect the wheel bearings.

The wheel bearings must be inspected at the intervals specified in the scheduled maintenance chart.

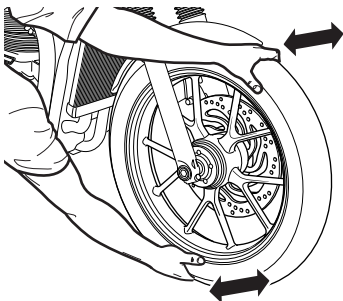

Inspecting the Wheel Bearings

To inspect the wheel bearings:

- Position the motorcycle on level ground, in an upright position.
- Raise the front wheel off the ground and support the motorcycle.
- Standing at the side of the motorcycle, gently rock the top of the front wheel from side to side.
- If any free play can be detected, ask your authorised Triumph dealer to inspect and rectify any faults before riding.

Maintenance and Adjustment

Front Suspension

Warning

Make sure that the adjusters are set to the same setting on both front suspension units.

Settings that vary from left to right may affect handling and stability resulting in loss of motorcycle control and an accident.

Warning

Make sure that the correct balance between front and rear suspension is maintained.

Suspension imbalance could significantly change handling characteristics leading to loss of control and an accident.

Refer to the table for further information or consult your authorised Triumph dealer.

The Thruxton R is fitted with adjustable front suspension. All other models have non-adjustable front suspension.

The standard suspension setting provides a comfortable ride and good handling characteristics for general, solo riding. The following tables show suggested settings for the front suspension.

Front Suspension Settings - Thruxton R

The motorcycle is delivered from the factory with all the suspension settings set at the Standard setting, as shown in the relevant suspension tables.

The details shown in the tables are only a guide. Setting requirements may vary for rider and passenger weight and personal preferences.

Preload Suspension Settings		
Loading Condition		Spring Preload ¹
Solo Riding	Standard	7.0
	Comfort (Softer)	7.0
	Sport (Firmer)	7.0
Rider and Passenger		7.0

¹ Number of adjuster turns clockwise from the fully anticlockwise position.

Damping Suspension Settings			
Loading Condition		Rebound Damping ²	Compression Damping ²
Solo Riding	Standard	5.0	5.25
	Comfort (Softer)	6.5	8.5
	Sport (Firmer)	2.0	2.0
Rider and Passenger		4.0	5.25

² Number of adjuster turns anticlockwise from the fully clockwise position.

Front Suspension Preload Adjustment - ThruXton R Only

The preload adjuster is located at the bottom of the front suspension unit.

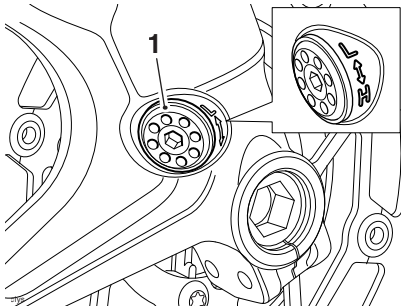

1. Front suspension preload adjuster

To adjust the preload setting:

- Rotate the adjuster clockwise to increase, or anticlockwise to decrease using the adjustment tool located in the right hand side panel.
- Always count the number of turns from the fully clockwise position.

Front Suspension Rebound and Compression Damping Adjustment - ThruXton R Only

The rebound and compression damping adjusters are located at the top of each fork.

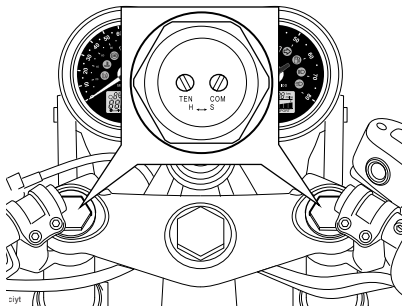

Front Suspension Rebound and Compression Damping Adjusters

To adjust the rebound damping setting:

- Rotate the TEN slotted adjuster clockwise to increase, or anticlockwise to decrease.
- Always count the number of turns from the fully clockwise position.

To adjust the compression damping setting:

- Rotate the COM slotted adjuster clockwise to increase, or anticlockwise to decrease.
- Always count the number of turns from the fully clockwise position.

Maintenance and Adjustment

Front Fork Inspection

Warning

Riding the motorcycle with defective or damaged suspension is dangerous and may lead to loss of control and an accident.

Warning

Never attempt to dismantle any part of the suspension units, as all units contain pressurised oil.

Skin and eye damage can result from contact with the pressurised oil.

To inspect the forks:

- Position the motorcycle on level ground.
- While holding the handlebars and applying the front brake, pump the forks up and down several times.
- If roughness or excessive stiffness is detected, consult your authorised Triumph dealer.
- Examine each fork for any sign of damage, scratching of the slider surface, or for oil leaks.
- If any damage or leakage is found, consult an authorised Triumph dealer.

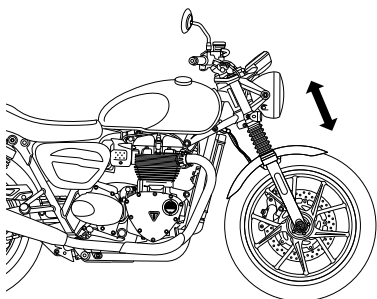

Street Twin Shown

Rear Suspension

Note

Thruxtion R suspension has three different rear adjustment settings; spring preload, rebound damping and compression damping.

All other models only have adjustable spring preload settings.

The Standard rear suspension preload settings provide a comfortable ride and good handling characteristics for general, solo riding. The following tables show suggested settings for rear suspension under different load conditions for all models.

Rear Suspension Settings

The details shown in the tables are only a guide. Setting requirements may vary for rider and passenger weight and personal preferences.

All Models except Thruxtion R

Preload Suspension Settings	
Loading Condition	Rear Spring Preload Adjuster Position
Solo Riding - Standard	1
Rider, Passenger and Luggage	5

Thruxtion R Only

Preload Suspension Settings		
Loading Condition		Rear Spring Preload ¹
Solo Riding	Standard	1
	Comfort (Softer)	1
	Sport (Firmer)	1
Rider and Passenger		3
¹ Position 1 is minimum (fully clockwise) and position 3 is maximum (fully anticlockwise).		

Damping Suspension Settings			
Loading Condition		Rear Rebound Damping ²	Rear Compression Damping ²
Solo Riding	Standard	24	16
	Comfort (Softer)	44	20
	Sport (Firmer)	12	8
Rider and Passenger		15	10
² Number of clicks anticlockwise from the fully clockwise position noting that the first stop (click) is counted as one.			

Rear Suspension Preload Adjustment

Warning

Make sure that the adjusters are set to the same setting on both rear suspension units.

Settings that vary from left to right may affect handling and stability resulting in loss of motorcycle control and an accident.

Maintenance and Adjustment

All Models except Thruxton R

Rear adjuster settings are counted from one with position one being with the adjuster turned fully anticlockwise.

There are five adjuster positions in total. Position five gives the maximum amount of spring preload.

The spring preload adjuster is located at the bottom of the rear suspension unit.

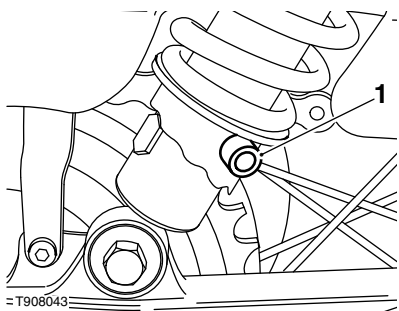

1. Rear suspension preload adjusters

To adjust the rear suspension spring preload setting:

- Insert the adjustment tool (located in the right hand side panel) into the hole in the adjuster ring.
- Turn the adjuster ring clockwise to increase spring preload, and anticlockwise to decrease spring preload. When delivered from the factory, the preload adjuster will be set at position one.

Rear Suspension Preload Adjustment - Thruxton R Only

The spring preload adjuster is located at the top of the rear suspension unit.

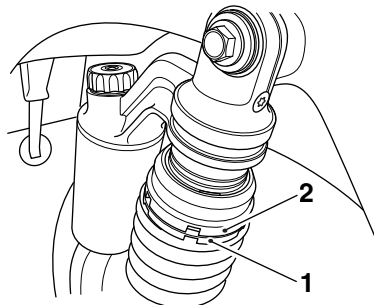

1. Lower adjuster ring
2. Top adjuster ring

To adjust the rear suspension spring preload setting:

- Use the two C-spanners located under the seat.
- Hold the top adjuster ring in place with one C-spanner, and adjust the lower adjuster ring with the other C-spanner.
- Turn the lower adjuster ring clockwise (viewed from above) to decrease spring preload and anticlockwise to increase spring preload. There are three defined positions to select from.

Maintenance and Adjustment

Rear Suspension Rebound Damping Adjustment - Thruxton R Only

The rebound damping adjuster is located at the bottom of the rear suspension unit.

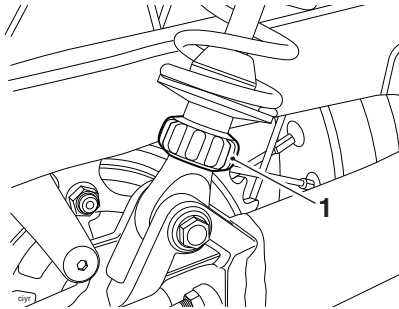

1. Rear suspension rebound damping adjuster

To adjust the rebound damping setting:

- Look upwards from the bottom of the suspension unit to the top of the suspension unit, and rotate the adjuster clockwise to increase and anticlockwise to decrease.
- Always count the number of adjuster clicks anticlockwise from the fully clockwise position.

Rear Suspension Compression Damping Adjustment - Thruxton R Only

The compression damping adjuster is located at the top of the rear suspension unit.

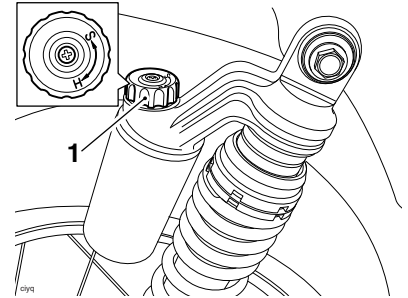

1. Rear suspension compression damping adjuster

To adjust the compression damping setting:

- Rotate the adjuster clockwise to increase, or anticlockwise to decrease.
- Always count the number of adjuster clicks anticlockwise from the fully clockwise position.

Maintenance and Adjustment

Bank Angle Indicators

Warning

Use of a motorcycle with bank angle indicators worn beyond the maximum limit will allow the motorcycle to be banked to an unsafe angle.

Banking to an unsafe angle may cause instability, loss of motorcycle control and an accident.

Bank angle indicators are located on the rider's footrests.

Regularly check the bank angle indicators for wear.

Bank angle indicators must be replaced when they have reached the maximum wear limit of 5 mm in length.

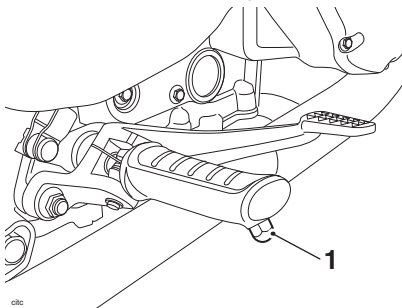

1. Bank angle indicator

Tyres



This motorcycle is equipped with spoked wheels which require a tyre suitable for use with an inner tube.

Warning

Failure to use an inner tube in a spoked wheel will cause deflation of the tyre resulting in loss of motorcycle control and an accident.

Maintenance and Adjustment

Warning

Inner tubes must only be used on motorcycles fitted with spoked wheels and with tyres marked 'TUBE TYPE'.

Some brands of approved tyres marked 'TUBELESS' may be suitable for use with an inner tube. Where this is the case, the tyre wall will be marked with text permitting the fitment of an inner tube (see illustration below).

Use of an inner tube with a tyre marked 'TUBELESS', and NOT marked as suitable for use with an inner tube, or use of an inner tube on an alloy wheel marked 'SUITABLE FOR TUBELESS TYRES' will cause deflation of the tyre resulting in loss of motorcycle control and an accident.

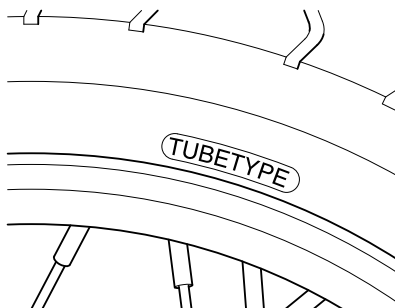

Typical Tyre Marking

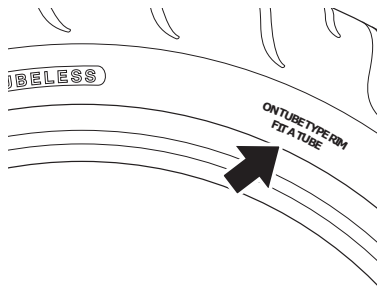

Typical Tyre Marking - Tubeless Tyre Suitable For Use With An Inner Tube

Tyre Inflation Pressures

Warning

Incorrect tyre inflation will cause abnormal tread wear and instability problems that may lead to loss of control and an accident.

Under inflation may result in the tyre slipping on, or coming off the rim. Overinflation will cause instability and accelerated tread wear.

Both conditions are dangerous as they may cause loss of control leading to an accident.

Correct inflation pressure will provide maximum stability, rider comfort and tyre life. Always check tyre pressures before riding when the tyres are cold. Check tyre pressures daily and adjust if necessary. See the Specification section for details of the correct inflation pressures.

Maintenance and Adjustment

Tyre Pressure Monitoring System (TPMS) (if fitted)

Caution

An adhesive label is fitted to the wheel rim to indicate the position of the tyre pressure sensor.

Care must be taken when replacing the tyres to prevent any damage to the tyre pressure sensors.

Always have your tyres fitted by your authorised Triumph dealer and inform them that tyre pressure sensors are fitted to the wheels.

Caution

Do not use anti puncture fluid or any other item likely to obstruct air flow to the TPMS sensor's orifices. Any blockage to the air pressure orifice of the TPMS sensor during operation will cause the sensor to become blocked, causing irreparable damage to the TPMS sensor assembly.

Damage caused by the use of anti puncture fluid or incorrect maintenance is not considered a manufacturing defect and will not be covered under warranty.

Always have your tyres fitted by your authorised Triumph dealer and inform them that tyre pressure sensors are fitted to the wheels.

The tyre pressures shown on your instruments indicate the actual tyre pressure at the time of selecting the display. This may differ from the inflation pressure set when the tyres are cold because tyres become warmer during riding, causing the air in the tyre to expand and increase the inflation pressure. The cold inflation pressures specified by Triumph take account of this.

Only adjust tyre pressures when the tyres are cold using an accurate pressure gauge. Do not use the tyre pressure display on the instruments.

Tyre Wear

As the tyre tread wears down, the tyre becomes more susceptible to punctures and failure. It is estimated that 90% of all tyre problems occur during the last 10% of tread life (90% worn). It is recommended that tyres are changed before they are worn to their minimum tread depth.

Minimum Recommended Tread Depth

Warning

Operation with excessively worn tyres is hazardous and will adversely affect traction, stability and handling which may lead to loss of control and an accident.

When tubeless tyres, used without a tube, become punctured, leakage is often very slow. Always inspect tyres very closely for punctures. Check the tyres for cuts, embedded nails or other sharp objects. Operation with punctured or damaged tyres will adversely affect motorcycle stability and handling which may lead to loss of control or an accident.

Check the rims for dents or deformation. Operation with damaged or defective wheels or tyres is dangerous and loss of motorcycle control or an accident could result.

Always consult your authorised Triumph dealer for tyre replacement, or for a safety inspection of the tyres.

In accordance with the periodic maintenance chart, measure the depth of the tread with a depth gauge, and replace any tyre that has worn to, or beyond the minimum allowable tread depth specified in the table below:

Under 80 mph (130 km/h)	2 mm (0.08 in)
Over 80 mph (130 km/h)	Front 2 mm (0.08 in) Rear 3 mm (0.12 in)

Tyre Replacement

All Triumph motorcycles are carefully and extensively tested in a range of riding conditions to ensure that the most effective tyre combinations are approved for use on each model. It is essential that approved tyres and inner tubes (if installed) fitted in approved combinations, are used when purchasing replacement items. The use of non-approved tyres and inner tubes, or approved tyres and inner tubes in non-approved combinations, may lead to motorcycle instability, loss of control and an accident.

A list of approved tyres and inner tubes specific to your motorcycle are available from your authorised Triumph dealer, or on the Internet at www.triumph.co.uk. Always have tyres and inner tubes fitted and balanced by your authorised Triumph dealer who has the necessary training and skills to ensure safe, effective fitment.

When replacement tyres or inner tubes are required, consult your authorised Triumph dealer who will arrange for the tyres and inner tubes to be selected, in a correct combination, from the approved list and fitted according to the tyre and inner tube manufacturer's instructions.

Initially, the new tyres and inner tubes will not produce the same handling characteristics as the worn tyres and inner tubes and the rider must allow adequate riding distance (approximately 100 miles (160 km)) to become accustomed to the new handling characteristics.

Maintenance and Adjustment

24 hours after fitting, the tyre pressures must be checked and adjusted, and the tyres and inner tubes examined for correct seating. Rectification must be carried out as necessary. The same checks and adjustments must also be carried out when 100 miles (160 km) have been travelled after fitting.

Warning

Inner tubes must only be used on motorcycles fitted with spoked wheels and with tyres marked 'TUBE TYPE'.

Some brands of approved tyres marked 'TUBELESS' may be suitable for use with an inner tube. Where this is the case, the tyre wall will be marked with text permitting the fitment of an inner tube.

Use of an inner tube with a tyre marked 'TUBELESS', and NOT marked as suitable for use with an inner tube, or use of an inner tube on an alloy wheel marked 'SUITABLE FOR TUBELESS TYRES' will cause deflation of the tyre resulting in loss of motorcycle control and an accident.

Warning

Do not install tube type tyres on tubeless rims.

The bead will not seat and the tyres could slip on the rims, causing rapid tyre deflation that may result in a loss of motorcycle control and an accident.

Never install an inner tube inside a tubeless tyre without the appropriate marking. This will cause friction inside the tyre and the resulting heat build-up may cause the tube to burst resulting in rapid tyre deflation, loss of motorcycle control and an accident.

Warning

If a tyre or inner tube sustains a puncture, the tyre and inner tube must be replaced.

Failure to replace a punctured tyre and inner tube, or operation with a repaired tyre or inner tube can lead to instability, loss of motorcycle control or an accident.

Warning

If tyre damage is suspected, such as after striking the kerb, ask your authorised Triumph dealer to inspect the tyre both internally and externally.

Tyre damage may not always be visible from the outside.

Operation of the motorcycle with damaged tyres could lead to loss of control and an accident.

Maintenance and Adjustment

Warning

Use of a motorcycle with incorrectly seated tyres or inner tubes, incorrectly adjusted tyre pressures, or when not accustomed to its handling characteristics may lead to loss of motorcycle control and an accident.

Warning

The ABS system operates by comparing the relative speed of the front and rear wheels.

Use of non-recommended tyres can affect wheel speed and cause the ABS function not to operate, potentially leading to loss of motorcycle control and an accident in conditions where the ABS would normally function.

Warning

Accurate wheel balance is necessary for safe, stable handling of the motorcycle. Do not remove or change any wheel balance weights. Incorrect wheel balance may cause instability leading to loss of control and an accident.

When wheel balancing is required, such as after tyre or inner tube replacement, see your authorised Triumph dealer.

Only use self-adhesive weights. Clip on weights may damage the wheel, tyre or inner tube resulting in tyre deflation, loss of motorcycle control and an accident.

Warning

Tyres and inner tubes that have been used on a rolling road dynamometer may become damaged. In some cases, the damage may not be visible on the external surface of the tyre.

Tyres and inner tubes must be replaced after such use as continued use of a damaged tyre or inner tube may lead to instability, loss of motorcycle control and an accident.

Maintenance and Adjustment

Battery

Warning

Under some circumstances, the battery can give off explosive gases; keep sparks, flames and cigarettes away. Provide adequate ventilation when charging or using the battery in an enclosed space.

The battery contains sulphuric acid (battery acid). Contact with skin or eyes may cause severe burns. Wear protective clothing and a face shield.

If battery acid gets on your skin, flush with water immediately.

If battery acid gets in your eyes, flush with water for at least 15 minutes and **SEEK MEDICAL ATTENTION IMMEDIATELY**.

If battery acid is swallowed, drink large quantities of water and **SEEK MEDICAL ATTENTION IMMEDIATELY**.

KEEP BATTERY ACID OUT OF THE REACH OF CHILDREN.

Warning

The battery contains harmful materials. Always keep children away from the battery whether or not it is fitted in the motorcycle.

Do not attach jump leads to the battery, touch the battery cables together or reverse the polarity of the cables as any of these actions may cause a spark which would ignite battery gases causing a risk of personal injury.

Battery Removal

Warning

Make sure that the battery terminals do not touch the motorcycle frame.

This may cause a short circuit or spark which would ignite battery gases causing a risk of personal injury.

Bonneville T100, Bonneville T120, Bonneville T120 Ace, Bonneville T120 Diamond, Street Scrambler and Street Twin

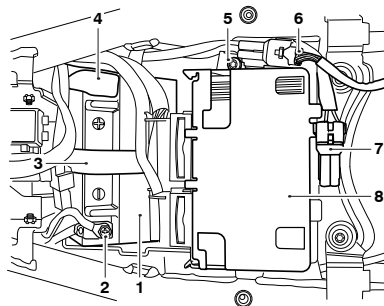

1. Battery
2. Negative (-) terminal
3. Battery strap
4. Positive (+) terminal
5. Fixing
6. Rear light cable
7. Accessory cable
8. Engine Control Module (ECM) unit

To remove the battery:

- Remove the seat (see page 72).
- Disconnect the battery leads, negative (black) lead first.
- Release the rear light and accessory cables.

Maintenance and Adjustment

- Release the fixing on the Engine Control Module (ECM) unit.
- Lift the ECM unit and place to the side allowing access to the battery.

Note

Make sure that the ECM unit is handled with care during the battery removal or installation process.

- Remove the battery strap.
- Detach the USB port socket.
- Take the battery out of the case.

Speed Twin, Thruxton and Thruxton R

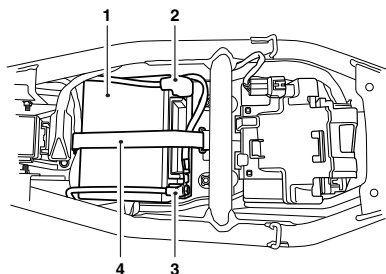

1. Battery
2. Positive (+) terminal
3. Negative (-) terminal
4. Battery strap

To remove the battery:

- Remove the seat (see page 72).
- Disconnect the battery leads, negative (black) lead first.
- Remove the battery strap and the USB port socket.
- Take the battery out of the case.

Battery Disposal

Should the battery ever require replacement, the original battery must be handed to a recycling agent who will make sure that the dangerous substances from which the battery is manufactured do not pollute the environment.

Battery Maintenance

Warning

Battery acid is corrosive and poisonous and will cause damage to unprotected skin.

Never swallow battery acid or allow it to come into contact with the skin.

To prevent injury, always wear eye and skin protection when handling the battery.

The battery is a sealed type and does not require any maintenance other than checking the voltage and routine recharging when required, such as during storage.

Clean the battery using a clean, dry cloth. Make sure that the cable connections are clean.

It is not possible to adjust the battery acid level in the battery; the sealing strip must not be removed.

Maintenance and Adjustment

Battery Discharge

Caution

The charge level in the battery must be maintained to maximise battery life. Failure to maintain the battery charge level could cause serious internal damage to the battery.

Under normal conditions, the motorcycle charging system will keep the battery fully charged. However, if the motorcycle is unused, the battery will gradually discharge due to a normal process called self discharge; the clock, Engine Control Module (ECM) memory, high ambient temperatures, or the addition of electrical security systems or other electrical accessories will all increase this rate of battery discharge. Disconnecting the battery from the motorcycle during storage will reduce the rate of discharge.

Battery Discharge During Storage and Infrequent Use of the Motorcycle

During storage or infrequent use of the motorcycle, inspect the battery voltage weekly using a digital multimeter. Follow the manufacturer's instructions supplied with the meter.

Should the battery voltage fall below 12.7 Volts, the battery should be charged.

Allowing a battery to discharge or leaving it discharged for even a short period of time causes sulphation of the lead plates. Sulphation is a normal part of the chemical reaction inside the battery, however over time the sulphate can crystallise on the plates making recovery difficult or impossible. This permanent damage is not covered by the motorcycle warranty, as it is not due to a manufacturing defect.

Keeping the battery fully charged reduces the likelihood of it freezing in cold conditions. Allowing a battery to freeze will cause serious internal damage to the battery.

Battery Charging

Warning

The battery gives off explosive gases; keep sparks, flames and cigarettes away. Provide adequate ventilation when charging or using the battery in an enclosed space.

The battery contains sulphuric acid (battery acid). Contact with skin or eyes may cause severe burns. Wear protective clothing and a face shield.

If battery acid gets on your skin, flush with water immediately.

If battery acid gets in your eyes, flush with water for at least 15 minutes and **SEEK MEDICAL ATTENTION IMMEDIATELY.**

If battery acid is swallowed, drink large quantities of water and **SEEK MEDICAL ATTENTION IMMEDIATELY.**

KEEP BATTERY ACID OUT OF THE REACH OF CHILDREN.

Caution

Do not use an automotive quick charger as it may overcharge and damage the battery.

For help with selecting a battery charger, checking the battery voltage or battery charging, contact your local authorised Triumph dealer.

Should the battery voltage fall below 12.7 Volts, the battery should be charged using a Triumph approved battery charger. Always remove the battery from the motorcycle and follow the instructions supplied with the battery charger.

For extended periods of storage (beyond two weeks) the battery should be removed from the motorcycle and kept charged using a Triumph approved maintenance charger.

Similarly, should the battery charge fall to a level where it will not start the motorcycle, remove the battery from the motorcycle before charging.

Battery Installation

Warning

Make sure that the battery terminals do not touch the motorcycle frame.

This may cause a short circuit or spark which would ignite battery gases causing a risk of personal injury.

Bonneville T100, Bonneville T120, Bonneville T120 Ace, Bonneville T120 Diamond, Street Scrambler and Street Twin

To install the battery:

- Place the battery in the battery case.
- Refit the USB port socket and secure with the battery strap.
- Reconnect the battery, positive lead (identified with red tape) first.
- Tighten the battery terminals to 4.5 Nm.
- Apply a light coat of grease to the terminals to prevent corrosion.
- Cover the positive terminal with the protective cap.
- Place the ECM unit in its original position.
- Reconnect the rear light and accessory cables.
- Refit the fixing to secure the ECM unit.
- Refit the seat (see page 72).

Maintenance and Adjustment

Speed Twin, Thruxton and Thruxton R

To install the battery:

- Place the battery in the battery case.
- Secure with the battery strap and make sure the USB port socket is refitted.
- Reconnect the battery, positive lead (identified with red tape) first.
- Tighten the battery terminals to 4.5 Nm.
- Apply a light coat of grease to the terminals to prevent corrosion.
- Cover the positive terminal with the protective cap.
- Refit the seat (see page 72).

Fuses

Warning

Always replace blown fuses with new ones of the correct rating (as specified on the fuse box cover) and never use a fuse of higher rating.

Use of an incorrect fuse could lead to an electrical problem, resulting in motorcycle damage, loss of motorcycle control and an accident.

Note

A blown fuse is indicated when all of the systems protected by that fuse become inoperative. When checking for a blown fuse, use the table to establish which fuse has blown.

The fuse box is located underneath the seat.

Maintenance and Adjustment

To allow access to the fuse box, the seat must be removed (see page 72).

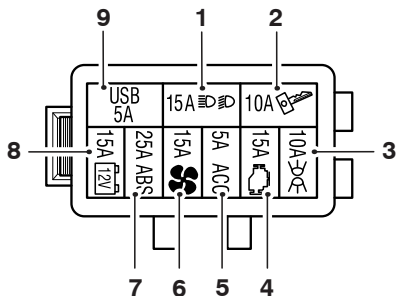

Fuse Box

Position	Circuit Protected	Rating (Amps)
1	Dip and high headlight beams	15
2	Ignition switch, starter circuit	10
3	Auxiliary lights	10
4	Engine management system	15
5	Accessory socket	5
6	Cooling fan	15
7	ABS	25
8	Instruments and alarm	15
9	USB port socket	5

Headlights



Warning

Adjust road speed to suit the visibility and weather conditions in which the motorcycle is being operated.

Make sure that the head light beam is adjusted to illuminate the road surface sufficiently far ahead without dazzling oncoming traffic.

An incorrectly adjusted headlight may impair visibility causing an accident.

Warning

Never attempt to adjust a headlight beam when the motorcycle is in motion.

Any attempt to adjust a headlight beam when the motorcycle is in motion may result in loss of control and an accident.

Maintenance and Adjustment

! Caution

Do not cover the headlight or lens with any item likely to obstruct air flow to, or prevent heat escaping from, the headlight lens.

Covering the headlight lens during operation with items of clothing, luggage, adhesive tape, devices intended to alter or adjust the headlight beam or non genuine headlight lens covers will cause the headlight lens to overheat and distort, causing irreparable damage to the headlight assembly.

Damage caused by overheating is not considered a manufacturing defect and will not be covered under warranty.

If the headlight must be covered during use - such as taping of the headlight lens required during closed-course conditions - the headlight must be disconnected.

! Caution

The use of non-approved headlight bulbs may result in damage to the headlight lens.

Use a genuine Triumph supplied headlight bulb as specified in the Triumph Parts Catalogue.

Always have replacement headlight bulbs installed by an authorised Triumph dealer.

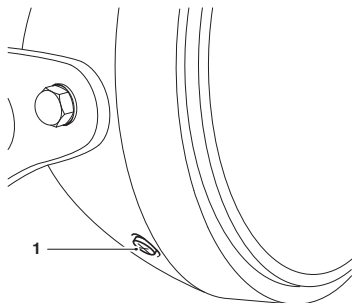

1. Headlight rim screws (one of two)

To remove the headlight rim:

- Disconnect the battery, negative (black) lead first.
- Remove the headlight rim screws.
- Detach the headlight and rim assembly from the headlight bowl.

Headlight/Position Light Bulb Replacement

! Warning

The bulbs become hot during use.

Always allow sufficient time for the bulbs to cool before handling.

Avoid touching the glass part of the bulb. If the glass is touched or gets dirty, clean with alcohol before reuse.

Maintenance and Adjustment

Bonneville T100, Street Scrambler and Street Twin

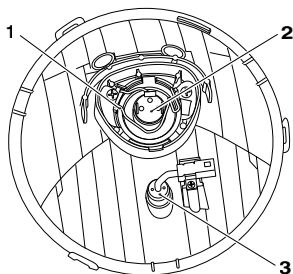

czy_1

1. Wire retainer
2. Headlight bulb
3. Position bulb

To remove the headlight and position light bulb:

- While supporting the light unit, disconnect the multipin electrical connector from the headlight bulb and the connector from the position light.
- Remove the rubber dust cover.
- Unhook the headlight bulb's wire retainer.
- The headlight bulb can now be removed.
- To remove the position light bulb, detach the bulb holder from the headlight body and release the bulb.
- Installation is the reversal of removal.

Bonneville T120, Bonneville T120 Ace, Bonneville T120 Diamond, Speed Twin, Thruxton and Thruxton R

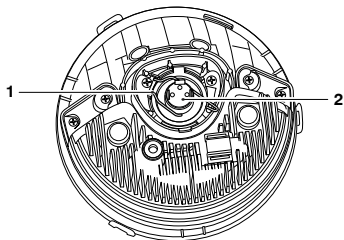

1. Wire retainer
2. Headlight bulb

To remove the headlight and position light bulb:

- While supporting the light unit, disconnect the multipin electrical connector from the headlight bulb.
- Remove the rubber dust cover.
- Unhook the headlight bulb's wire retainer.
- The headlight bulb can now be removed.
- Installation is the reversal of removal.
- The position bulb is situated within the headlight assembly and is a sealed, maintenance-free LED unit.

Daytime Running Lights (if fitted)

The Daytime Running Lights (DRL) are situated within the headlight assembly and are sealed, maintenance free LED units. If DRL are fitted then there is no position bulb.

Maintenance and Adjustment

Headlight Adjustment

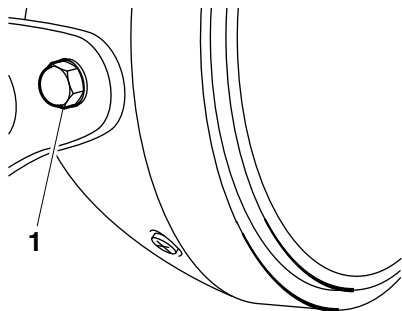

1. Headlight assembly mounting bolt

To adjust the headlight beam:

- Always make sure the handlebars are in the straight ahead position.
- Vertical adjustment of the headlight beam is controlled by loosening the headlight assembly mounting bolts and altering the position of the headlight assembly.
- Retighten the headlight assembly mounting bolts after adjustment to 10 Nm.

Rear Lights

The LED rear light units are sealed, maintenance free LED units. The rear light units must be replaced in the event of the failure of the rear lights.

Multifunctional Rear Lights (if fitted)

Bonneville T120 Ace and Speed Twin

The multifunctional rear light units operate as the rear position light, brake light and direction indicators.

The multifunctional rear light units are a sealed, maintenance free LED unit and must be replaced in the event of the failure of the rear lights.

Direction Indicator Lights

The motorcycle is fitted with either LED or bulb direction indicator lights.

LED Direction Indicator Lights

The LED direction indicator light units are sealed, maintenance free LED units. The direction indicator light assembly must be replaced in the event of the failure of the direction indicator.

Street Scrambler and Street Twin Direction Indicator Bulb Replacement

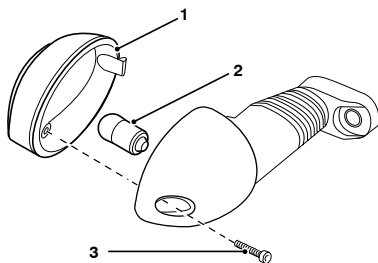

1. Lens
2. Bulb
3. Indicator lens screw

The lens on each indicator light is held in place by an indicator lens screw located in the body of the light unit.

To replace the direction indicator light bulb:

- Release the indicator lens screw and remove the lens to gain access to the bulb for replacement.
- Carefully remove the bulb and replace it with a new bulb.
- Installation is the reverse of the removal procedure.

Bonneville T100, Bonneville T120, Thruxton and Thruxton R Direction Indicator Bulb Replacement

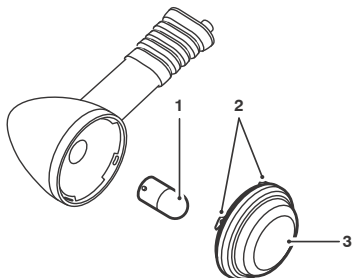

1. Bulb
2. Locating tangs
3. Lens

To replace the direction indicator light bulb:

- Carefully twist the lens anticlockwise and remove from the indicator to gain access to the bulb.
- Gently press the bulb inwards and twist anticlockwise. Replace with a new bulb.
- Installation for the bulb is the reverse of the removal procedure.

Caution

When installing the lens, make sure that the locating tangs are correctly aligned to the indicator body.

- To install the indicator lens, align the locating tangs with the indicator body and twist anticlockwise to secure.

Maintenance and Adjustment

License Plate Light

Bonneville T120 Ace, Bonneville T120 Diamond and Speed Twin

The license plate light unit is a sealed, maintenance free LED unit. The license plate light unit must be replaced in the event of the failure of the license plate light.

Street Scrambler and Street Twin

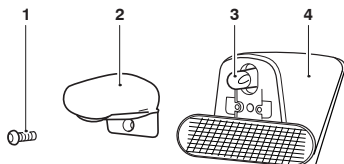

1. Fixing
2. Lens unit
3. Bulb
4. License plate bracket

To change the license plate light bulb:

- Disconnect the battery, negative black lead first.
- Release the fixing from the lens unit.
- Remove the lens unit from the license plate bracket.

- Detach the bulb retainer from the lens unit.

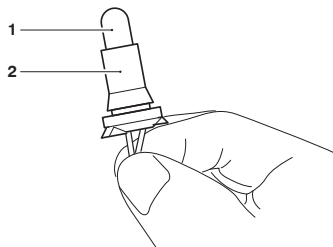

1. Bulb
 2. Bulb retainer
- Carefully remove the bulb from the bulb retainer. Fit a new bulb into the bulb retainer.
 - Refit the bulb retainer into the lens unit.
 - Refit the lens unit to the license plate bracket.
 - Tighten the fixing to 1 Nm.
 - Reconnect the battery, positive (red) lead first and tighten the battery terminals to 4.5 Nm.
 - Apply a light coat of grease to the terminals to prevent corrosion.
 - Cover the positive terminal with the protective cap.

Cleaning and Storage

Table of Contents

Cleaning.....	150
Preparation for Washing.....	150
Where to be Careful.....	151
Washing.....	151
After Washing.....	152
Care of Gloss Paintwork.....	152
Care of Matt Paintwork.....	152
Aluminium Items - not Lacquered or Painted.....	152
Cleaning of Chrome and Stainless Steel Items.....	153
Black Chrome.....	153
Cleaning of the Exhaust System.....	154
Seat Care.....	155
Windscreen Cleaning (if fitted).....	155
Care of Leather Products.....	156
Storage.....	157

Cleaning and Storage

Cleaning

Frequent, regular cleaning is an essential part of the maintenance of your motorcycle. If regularly cleaned, the appearance will be preserved for many years.

Cleaning with cold water containing an automotive cleaner is essential at all times but particularly so after exposure to sea breezes, sea water, dusty or muddy roads and in winter when roads are treated for ice and snow.

Do not use household detergent, as the use of such products will lead to premature corrosion.

Although, under the terms of your motorcycle warranty, cover is provided against the corrosion of certain items, the owner is expected to observe this reasonable advice which will safeguard against corrosion and enhance the appearance of the motorcycle.

Preparation for Washing

Before washing, precautions must be taken to keep water off the following places.

Rear opening of the exhausts: Cover with a plastic bag secured with rubber bands.

Clutch and brake levers, switch housings on the handlebar: Cover with plastic bags.

Ignition switch and steering lock: Cover the keyhole with tape.

Remove any items of jewellery such as rings, watches, zips or belt buckles, which may scratch or otherwise damage painted or polished surfaces.

Use separate cleaning sponges or cleaning cloths for washing painted/polished surfaces and chassis areas. Chassis areas (such as wheels and under mudguards) will be exposed to more abrasive road grime and dust, which may then scratch painted or polished surfaces, if the same sponge or cleaning cloths are used.

Where to be Careful

Caution

Do not spray any water at all near the air intake duct.

The air intake duct is normally located under the rider's seat, under the fuel tank or near the steering head.

Any water sprayed in this area could enter the airbox and engine, causing damage to both items.

Caution

Use of high pressure spray washers is not recommended.

When using pressure washers, water may be forced into bearings and other components causing premature wear from corrosion and loss of lubrication.

Avoid spraying water with any great force near the following places:

- Instruments,
- Brake cylinders and brake calipers,
- Under the fuel tank,
- Air intake duct,
- Headstock bearings,
- Wheel bearings,
- Suspension seals and bearings.

Note

Use of soaps that are highly alkaline will leave a residue on painted surfaces, and may also cause water spotting.

Always use a low alkaline soap to aid the cleaning process.

Washing

Prepare a mixture of cold water and mild automotive cleaner. Do not use a highly alkaline soap as commonly found at commercial car washes because it leaves a residue.

Wash the motorcycle with a sponge or soft cloth. Do not use abrasive scouring pads or steel wool. They will damage the finish.

Rinse the motorcycle thoroughly with cold water.

Cleaning and Storage

After Washing

Warning

Never wax or lubricate the brake discs. Loss of braking power and an accident could result. Clean the disc with a proprietary brand of oil-free brake disc cleaner.

Remove the plastic bags and tape, and clear the air intakes.

Lubricate the pivots, bolts and nuts.

Test the brakes before motorcycle operation.

Use a dry cloth or chamois leather to absorb water residue. Do not allow water to stand on the motorcycle as this will lead to corrosion.

Start the engine and run it for 5 minutes. Make sure that there is adequate ventilation for the exhaust fumes.

Care of Gloss Paintwork

Gloss paintwork should be washed and dried as described above, then protected using a high quality automotive polish. Always follow the manufacturer's instructions and repeat regularly to maintain your motorcycle's appearance.

Care of Matt Paintwork

Matt paintwork requires no greater care than that already recommended for high gloss paintwork.

- Do not use any polish or wax on matt paintwork.
- Do not try and polish out scratches.

Aluminium Items - not Lacquered or Painted

Items such as brake and clutch levers, wheels, engine covers, engine cooling fins, upper and lower yokes and throttle bodies on some models must be correctly cleaned to preserve their appearance. Please contact your dealer if you are unsure which components on your motorcycle are aluminium parts not protected by paint or lacquer, and for guidance on how to clean those items.

Use a proprietary brand of aluminium cleaner which does not contain abrasive or caustic elements.

Clean aluminium items regularly, in particular after use in inclement weather, where the components must be hand washed and dried each time the machine is used.

Warranty claims due to inadequate maintenance will not be allowed.

Cleaning of Chrome and Stainless Steel Items

All chrome and stainless steel parts of your motorcycle must be cleaned regularly to avoid a deterioration of its appearance.

Washing

Wash as previously described.

Drying

Dry the chrome and stainless steel parts as far as possible with a soft cloth or chamois leather.

Protecting

**Caution**

The use of products containing silicone will cause discolouration of the chrome and stainless steel parts and must not be used. Similarly, the use of abrasive cleaners will damage the finish and must not be used.

When the chrome and stainless steel is dry, apply a suitable proprietary chrome cleaner on to the surface, following the manufacturer's instructions.

It is recommended that regular protection be applied to the motorcycle as this will both protect and enhance its appearance.

Black Chrome

Items such as headlight bowls and mirrors on some models must be correctly cleaned to preserve their appearance. Please contact your dealer if you are unsure which components on your motorcycle are black chrome parts. Maintain the appearance of black chrome items by rubbing a small amount of light oil into the surface.

Cleaning and Storage

Cleaning of the Exhaust System

All parts of the exhaust system of your motorcycle must be cleaned regularly to avoid a deterioration of its appearance. These instructions can be applied to chrome, brushed stainless steel and carbon fibre components; matt painted exhaust systems should be cleaned as above, noting the care instructions in the Matt Paintwork section previously.

Note

The exhaust system must be cool before washing to prevent water spotting.

Washing

Wash as previously described.

Make sure that no soap or water enters the exhausts.

Drying

Dry the exhaust system as far as possible with a soft cloth or chamois leather. Do not run the engine to dry the system or spotting will occur.

Protecting

Caution

The use of products containing silicone will cause discolouration of the chrome and must not be used. Similarly, the use of abrasive cleaners will damage the system and must not be used.

When the exhaust system is dry, apply a suitable proprietary motorcycle protection spray onto the surface, following the manufacturer's instructions.

It is recommended that regular protection be applied to the system as this will both protect and enhance the system's appearance.

Seat Care

Caution

Use of chemicals or high pressure spray washers is not recommended for cleaning the seat.

Using chemicals or high pressure spray washers may damage the seat cover.

To help maintain its appearance, clean the seat using a sponge or cleaning cloth with soap and water.

Windscreen Cleaning (if fitted)



Warning

Never attempt to clean the windscreen while the motorcycle is in motion as releasing the handlebars may cause loss of motorcycle control and an accident.

Operation of the motorcycle with a damaged or scratched windscreen will reduce the rider's forward vision. Any such reduction in forward vision is dangerous and may lead to loss of motorcycle control and an accident.

Caution

Corrosive chemicals such as battery acid will damage the windscreen. Never allow corrosive chemicals to contact the windscreen.

Caution

Products such as window cleaning fluids, insect remover, rain repellent, scouring compounds, petrol or strong solvents such as alcohol, acetone, carbon tetrachloride, etc. will damage the windscreen.

Never allow these products to contact the windscreen.

Cleaning and Storage

Clean the windscreen with a solution of mild soap or detergent and cold water.

After cleaning, rinse well and then dry with a soft, lint-free cloth.

If the transparency of the windscreen is reduced by scratches or oxidation which cannot be removed, the windscreen must be replaced.

Care of Leather Products

We recommend that you periodically clean your leather products with a damp cloth and allow them to dry naturally at room temperature. This will maintain the appearance of the leather and ensure the long life of your product.

Your Triumph leather product is a natural product and lack of care can result in damage and permanent wear. Follow these simple instructions and give your leather product the respect it deserves:

- Do not use household cleaning products, bleach, detergents containing bleach or any kind of solvent to clean your leather product.
- Do not immerse your leather product in water.
- Avoid direct heat from fires and radiators which can dry out and distort the leather.
- Do not leave your leather product in direct sunlight for prolonged periods of time.
- Do not dry your leather product by applying direct heat to it at any time.
- If your leather product does get wet, absorb any excess water with a soft clean cloth then leave the product to dry naturally at room temperature.
- Avoid exposure of your leather product to high levels of salt, for example sea/salt water or road surfaces that have been treated during the winter for ice and snow.

- If exposure to salt is unavoidable, clean your leather product immediately after each exposure using a damp cloth then leave the product to dry naturally at room temperature.
- Gently clean any minor marks with a damp cloth then leave the product to dry naturally at room temperature.
- Place your leather product in a fabric bag or cardboard box to protect it when in storage. Do not use a plastic bag.

Storage

Preparation for Storage

To prepare the motorcycle for storage, do the following:

- Clean and dry the entire vehicle thoroughly.
- Fill the fuel tank with the correct grade of unleaded fuel and add a suitable fuel stabiliser (if available), following the fuel stabiliser manufacturer's instructions.

Warning

Petrol is extremely flammable and can be explosive under certain conditions.

Turn the ignition switch OFF. Do not smoke.

Make sure the area is well ventilated and free from any source of flame or sparks; this includes any appliance with a pilot light.

- Remove one of the spark plugs from each cylinder and put several drops (5 ml) of engine oil into each cylinder. Cover the spark plug holes with a piece of cloth or rag. With the engine stop switch in the RUN position, push the starter button for a few seconds to coat the cylinder walls with oil. Install the spark plugs, tightening to 12 Nm.
- Change the engine oil and filter (see page 104).
- Check and if necessary correct the tyre pressures (see page 133).

Cleaning and Storage

- Set the motorcycle on a stand so that both wheels are raised off the ground. (If this cannot be done, put boards under the front and rear wheels to keep dampness away from the tyres.)
- Spray rust inhibiting oil (there are a host of products on the market and your authorised Triumph dealer will be able to offer you local advice) on all unpainted metal surfaces to prevent rusting. Prevent oil from getting on rubber parts, brake discs or in the brake calipers.
- Make sure the cooling system is filled with a 50% mixture of coolant (noting that HD4X Hybrid OAT coolant, as supplied by Triumph, is pre-mixed and requires no dilution) and distilled water solution (see page 107).
- Remove the battery, and store it where it will not be exposed to direct sunlight, moisture, or freezing temperatures. During storage it should be given a slow charge (one Ampere or less) about once every two weeks (see page 140).
- Store the motorcycle in a cool, dry area, away from sunlight, and with a minimum daily temperature variation.
- Put a suitable porous cover over the motorcycle to keep dust and dirt from collecting on it. Avoid using plastic or similar non-breathable, coated materials that restrict air flow and allow heat and moisture to accumulate.

Preparation after Storage

To prepare the motorcycle to be ridden after storage, do the following:

- Install the battery (if removed) (see page 141).
- If the motorcycle has been stored for more than four months, change the engine oil (see page 104).
- Check all the points listed in the Daily Safety Checks section.
- Before starting the engine, remove the spark plugs from each cylinder.
- Put the side stand down.
- Crank the engine on the starter motor several times until the oil pressure light goes out.
- Replace the spark plugs, tightening to 12 Nm, and start the engine.
- Check and if necessary correct the tyre pressures (see page 133).
- Check and if necessary adjust the drive chain tension (see page 114).
- Clean the entire vehicle thoroughly.
- Check the brakes for correct operation.
- Test ride the motorcycle at low speeds.

Specifications - Bonneville T100 and Bonneville T120

Specifications - Bonneville T100 and Bonneville T120

Dimensions, Weights and Performance

A list of model specific dimensions, weights and performance figures is available from your authorised Triumph dealer, or on the Internet at www.triumph.co.uk.

Payload	Bonneville T100	Bonneville T120
Maximum Payload	210 kg (463 lb)	210 kg (463 lb)
Engine	Bonneville T100	Bonneville T120
Type	Liquid cooled parallel twin, 270° firing angle	Liquid cooled parallel twin, 270° firing angle
Displacement	900 cc	1,200 cc
Bore x Stroke	84.6 x 80 mm	97.6 x 80 mm
Compression Ratio	10.5:1	10:1
Cylinder Numbering	Left to right	Left to right
Cylinder Sequence	1-2	1-2
Firing Order	1-2	1-2
Starting System	Electric starter	Electric starter
Lubrication	Bonneville T100	Bonneville T120
Lubrication System	Wet sump	Wet sump
Engine Oil Capacities:		
Dry Fill	3.8 litres	3.8 litres
Oil/Filter Change	3.4 litres	3.4 litres
Oil Change Only	3.2 litres	3.2 litres
Cooling	Bonneville T100	Bonneville T120
Coolant Type	Triumph HD4X Hybrid OAT	Triumph HD4X Hybrid OAT
Water/Coolant Ratio	50/50 (pre-mixed as supplied by Triumph)	50/50 (pre-mixed as supplied by Triumph)
Coolant Capacity	1.518 litres	1.558 litres
Thermostat Opens	88°C +/- 2°C	88°C +/- 2°C
Fuel System	Bonneville T100	Bonneville T120
Type	Electronic fuel injection	Electronic fuel injection
Fuel Pump	Submerged electronic	Submerged electronic
Fuel Pressure (nominal)	3.5 bar	3.5 bar

Specifications - Bonneville T100 and Bonneville T120

Fuel	Bonneville T100	Bonneville T120
Type	91 RON unleaded	91 RON unleaded
Tank Capacity	14.5 litres	14.5 litres
Ignition	Bonneville T100	Bonneville T120
Ignition System	Digital inductive	Digital inductive
Spark Plug	NGK LMAR8A-9	NGK LMAR8A-9
Spark Plug Gap	0.9 mm +0.0/- 0.1 mm	0.9 mm +0.0/- 0.1 mm
Transmission	Bonneville T100	Bonneville T120
Transmission Type	5 speed, constant mesh	6 speed, constant mesh
Clutch Type	Wet, multiplate	Wet, multiplate
Final Drive Chain	DID 520 VP2-T, 102 link	RK 525 KRW2, 100 link
Primary Drive Ratio	93/74 (1.26)	93/74 (1.26)
Gear Ratio:		
1st	49/14 (3.5)	49/14 (3.5)
2nd	45/18 (2.5)	45/18 (2.5)
3rd	37/20 (1.85)	37/20 (1.85)
4th	37/25 (1.48)	37/25 (1.48)
5th	35/27 (1.3)	35/27 (1.3)
6th	N/A	34/29 (1.17)
Final Drive Ratio	41/17 (2.41)	37/17 (2.18)



Warning

Use the recommended tyres **ONLY** in the combinations given.

Do not mix tyres from different manufacturers or mix different specification tyres from the same manufacturers as this may result in loss of motorcycle control and an accident.

Approved Tyres

A list of approved tyres specific to these models is available from your authorised Triumph dealer, or on the Internet at www.triumph.co.uk.

Specifications - Bonneville T100 and Bonneville T120

Tyres	Bonneville T100	Bonneville T120
Tyre Sizes:		
Front	100/90-18	100/90-18
Rear	150/70 R17	150/70 R17
Tyre Pressures (Cold):		
Front	2.2 bar (32 lbs/in ²)	2.2 bar (32 lbs/in ²)
Rear	2.5 bar (36 lbs/in ²)	2.5 bar (36 lbs/in ²)
Electrical Equipment		
Battery Type	YTX12-BS	YTX12-BS
Battery Rating	12 Volt, 10 Ah	12 Volt, 10 Ah
Alternator	25 Amps at 1,000 rpm	25 Amps at 1,000 rpm
	46.5 Amps at 3,000 rpm	46.5 Amps at 3,000 rpm
Headlight	12 Volt, 60/55 Watt, H4 halogen	12 Volt, 60/55 Watt, H4 halogen
Tail/Brake Light	LED	LED
Directional Indicator Lights	12 Volt, 10 Watt	12 Volt, 10 Watt
Frame		
Rake	25.5°	25.5°
Trail	105.2 mm (4.14 in)	105.2 mm (4.14 in)
Tightening Torques		
Battery Terminals		4.5 Nm
Chain Adjuster Lock Nuts		20 Nm
Chain Guard		9 Nm
Clutch Lever Nut		3.5 Nm
Oil Filter		10 Nm
Spark Plug		12 Nm
Sump Plug		25 Nm
Rear Wheel Spindle Nut		110 Nm

Specifications - Bonneville T100 and Bonneville T120

Fluids and Lubricants

Bearings and Pivots	Grease to NLGI 2 specification
Brake Fluid	DOT 4 brake fluid
Coolant	Triumph HD4X Hybrid OAT coolant (pre-mixed)
Drive Chain	Chain spray suitable for XW-ring chains Semi or fully synthetic 10W/40 or 10W/50 motorcycle engine oil which meets specification API SH (or higher) and JASO MA, such as Castrol Power 1 Racing 4T 10W-40 (fully synthetic) engine oil, sold as Castrol Power RS Racing 4T 10W-40 (fully synthetic) in some countries.
Engine Oil	

Specifications - Bonneville T120 Ace and Diamond

Specifications - Bonneville T120 Ace and Diamond

Dimensions, Weights and Performance

A list of model specific dimensions, weights and performance figures is available from your authorised Triumph dealer, or on the Internet at www.triumph.co.uk.

Payload	Bonneville T120 Ace	Bonneville T120 Diamond
Maximum Payload	210 kg (463 lb)	210 kg (463 lb)
Engine	Bonneville T120 Ace	Bonneville T120 Diamond
Type	Liquid cooled parallel twin, 270° firing angle	Liquid cooled parallel twin, 270° firing angle
Displacement	1,200 cc	1,200 cc
Bore x Stroke	97.6 x 80 mm	97.6 x 80 mm
Compression Ratio	10:1	10:1
Cylinder Numbering	Left to right	Left to right
Cylinder Sequence	1-2	1-2
Firing Order	1-2	1-2
Starting System	Electric starter	Electric starter
Lubrication	Bonneville T120 Ace	Bonneville T120 Diamond
Lubrication System	Wet sump	Wet sump
Engine Oil Capacities:		
Dry Fill	3.8 litres	3.8 litres
Oil/Filter Change	3.4 litres	3.4 litres
Oil Change Only	3.2 litres	3.2 litres
Cooling	Bonneville T120 Ace	Bonneville T120 Diamond
Coolant Type	Triumph HD4X Hybrid OAT	Triumph HD4X Hybrid OAT
Water/Coolant Ratio	50/50 (pre-mixed as supplied by Triumph)	50/50 (pre-mixed as supplied by Triumph)
Coolant Capacity	1.558 litres	1.558 litres
Thermostat Opens	88°C +/- 2°C	88°C +/- 2°C
Fuel System	Bonneville T120 Ace	Bonneville T120 Diamond
Type	Electronic fuel injection	Electronic fuel injection
Fuel Pump	Submerged electronic	Submerged electronic
Fuel Pressure (nominal)	3.5 bar	3.5 bar

Specifications - Bonneville T120 Ace and Diamond

Fuel	Bonneville T120 Ace	Bonneville T120 Diamond
Type	91 RON unleaded	91 RON unleaded
Tank Capacity	14.5 litres	14.5 litres
Ignition	Bonneville T120 Ace	Bonneville T120 Diamond
Ignition System	Digital inductive	Digital inductive
Spark Plug	NGK LMAR8A-9	NGK LMAR8A-9
Spark Plug Gap	0.9 mm +0.0/- 0.1 mm	0.9 mm +0.0/- 0.1 mm
Transmission	Bonneville T120 Ace	Bonneville T120 Diamond
Transmission Type	6 speed, constant mesh	6 speed, constant mesh
Clutch Type	Wet, multiplate	Wet, multiplate
Final Drive Chain	RK 525 KRW2, 100 link	RK 525 KRW2, 100 link
Primary Drive Ratio	93/74 (1.26)	93/74 (1.26)
Gear Ratio:		
1st	49/14 (3.5)	49/14 (3.5)
2nd	45/18 (2.5)	45/18 (2.5)
3rd	37/20 (1.85)	37/20 (1.85)
4th	37/25 (1.48)	37/25 (1.48)
5th	35/27 (1.3)	35/27 (1.3)
6th	34/29 (1.17)	34/29 (1.17)
Final Drive Ratio	37/17 (2.18)	37/17 (2.18)



Warning

Use the recommended tyres **ONLY** in the combinations given.

Do not mix tyres from different manufacturers or mix different specification tyres from the same manufacturers as this may result in loss of motorcycle control and an accident.

Approved Tyres

A list of approved tyres specific to these models is available from your authorised Triumph dealer, or on the Internet at www.triumph.co.uk.

Specifications - Bonneville T120 Ace and Diamond

Tyres	Bonneville T120 Ace	Bonneville T120 Diamond
Tyre Sizes:		
Front	100/90-18	100/90-18
Rear	150/70 R17	150/70 R17
Tyre Pressures (Cold):		
Front	2.2 bar (32 lbs/in ²)	2.2 bar (32 lbs/in ²)
Rear	2.5 bar (36 lbs/in ²)	2.5 bar (36 lbs/in ²)
Electrical Equipment		
Battery Type	YTX12-BS	YTX12-BS
Battery Rating	12 Volt, 10 Ah	12 Volt, 10 Ah
Alternator	25 Amps at 1,000 rpm	25 Amps at 1,000 rpm
	46.5 Amps at 3,000 rpm	46.5 Amps at 3,000 rpm
Headlight	12 Volt, 60/55 Watt, H4 halogen	12 Volt, 60/55 Watt, H4 halogen
Tail/Brake Light	LED	LED
Directional Indicator Lights	LED	LED
Frame		
Rake	25.5°	25.5°
Trail	105.2 mm (4.14 in)	105.2 mm (4.14 in)
Tightening Torques		
Battery Terminals		4.5 Nm
Chain Adjuster Lock Nuts		20 Nm
Chain Guard		9 Nm
Clutch Lever Nut		3.5 Nm
Oil Filter		10 Nm
Spark Plug		12 Nm
Sump Plug		25 Nm
Rear Wheel Spindle Nut		110 Nm

Specifications - Bonneville T120 Ace and Diamond

Fluids and Lubricants

Bearings and Pivots	Grease to NLGI 2 specification
Brake Fluid	DOT 4 brake fluid
Coolant	Triumph HD4X Hybrid OAT coolant (pre-mixed)
Drive Chain	Chain spray suitable for XW-ring chains Semi or fully synthetic 10W/40 or 10W/50 motorcycle engine oil which meets specification API SH (or higher) and JASO MA, such as Castrol Power 1 Racing 4T 10W-40 (fully synthetic) engine oil, sold as Castrol Power RS Racing 4T 10W-40 (fully synthetic) in some countries.
Engine Oil	

Specifications - Street Scrambler

Dimensions, Weights and Performance

A list of model specific dimensions, weights and performance figures is available from your authorised Triumph dealer, or on the Internet at www.triumph.co.uk.

Payload

Maximum Payload

Street Scrambler

223 kg (492 lb)

Engine

Type

Street Scrambler

Liquid cooled parallel twin, 270° firing angle

Displacement

900 cc

Bore x Stroke

84.6 x 80 mm

Compression Ratio

11:1

Cylinder Numbering

Left to right

Cylinder Sequence

1-2

Firing Order

1-2

Starting System

Electric starter

Lubrication

Lubrication System

Street Scrambler

Wet sump

Engine Oil Capacities:

Dry Fill

3.8 litres

Oil/Filter Change

3.4 litres

Oil Change Only

3.2 litres

Cooling

Coolant Type

Street Scrambler

Triumph HD4X Hybrid OAT

Water/Coolant Ratio

50/50 (pre-mixed as supplied by Triumph)

Coolant Capacity

1.518 litres

Thermostat Opens

88°C +/- 2°C

Fuel System

Type

Street Scrambler

Electronic fuel injection

Fuel Pump

Submerged electronic

Fuel Pressure (nominal)

3.5 bar

Specifications - Street Scrambler

Fuel	Street Scrambler
Type	91 RON unleaded
Tank Capacity	12.0 litres
Ignition	Street Scrambler
Ignition System	Digital inductive
Spark Plug	NGK LMAR8A-9
Spark Plug Gap	0.9 mm +0.0/-0.1 mm
Transmission	Street Scrambler
Transmission Type	5 speed, constant mesh
Clutch Type	Wet, multiplate
Final Drive Chain	DID 520 VP2-T, 102 link
Primary Drive Ratio	93/74 (1.26)
Gear Ratio:	
1st	49/14 (3.5)
2nd	45/18 (2.5)
3rd	37/20 (1.85)
4th	37/25 (1.48)
5th	35/27 (1.3)
Final Drive Ratio	41/17 (2.41)

Warning

Use the recommended tyres **ONLY** in the combinations given.

Do not mix tyres from different manufacturers or mix different specification tyres from the same manufacturers as this may result in loss of motorcycle control and an accident.

Approved Tyres

A list of approved tyres specific to these models is available from your authorised Triumph dealer, or on the Internet at www.triumph.co.uk.

Tyres	Street Scrambler
Tyre Sizes:	
Front	100/90-19
Rear	150/70 R17

Specifications - Street Scrambler

Tyres

Tyre Pressures (Cold):

Front

2.1 bar (30 lbs/in²)

Rear

2.5 bar (36 lbs/in²)

Electrical Equipment

Battery Type

YTX12-BS

Battery Rating

12 Volt, 10 Ah

Alternator

25 Amps at 1,000 rpm

46.5 Amps at 3,000 rpm

Headlight

12 Volt, 60/55 Watt, H4 halogen

Tail/Brake Light

LED

Directional Indicator Lights

12 Volt, 10 Watt

License Plate Light

12 Volt, 5 Watt

Frame

Rake

25.6°

Trail

109.6 mm (4.31 in)

Tightening Torques

Battery Terminals

4.5 Nm

Chain Adjuster Lock Nuts

20 Nm

Chain Guard

9 Nm

Clutch Lever Nut

3.5 Nm

Oil Filter

10 Nm

Passenger Seat Fastener

3 Nm

Spark Plug

12 Nm

Sump Plug

25 Nm

Rear Wheel Spindle Nut

110 Nm

Specifications - Street Scrambler

Fluids and Lubricants

Bearings and Pivots	Grease to NLGI 2 specification
Brake Fluid	DOT 4 brake fluid
Coolant	Triumph HD4X Hybrid OAT coolant (pre-mixed)
Drive Chain	Chain spray suitable for XW-ring chains Semi or fully synthetic 10W/40 or 10W/50 motorcycle engine oil which meets specification API SH (or higher) and JASO MA, such as Castrol Power 1 Racing 4T 10W-40 (fully synthetic) engine oil, sold as Castrol Power RS Racing 4T 10W-40 (fully synthetic) in some countries.
Engine Oil	

Specifications - Speed Twin

Dimensions, Weights and Performance

A list of model specific dimensions, weights and performance figures is available from your authorised Triumph dealer, or on the Internet at www.triumph.co.uk.

Payload

Maximum Payload

Speed Twin

212 kg (467 lb)

Engine

Type

Speed Twin

Liquid cooled parallel twin, 270° firing angle

Displacement

1200 cc

Bore x Stroke

97.6 x 80 mm

Compression Ratio

11:1

Cylinder Numbering

Left to right

Cylinder Sequence

1-2

Firing Order

1-2

Starting System

Electric starter

Lubrication

Lubrication System

Speed Twin

Wet sump

Engine Oil Capacities:

Dry Fill

3.8 litres

Oil/Filter Change

3.4 litres

Oil Change Only

3.2 litres

Cooling

Coolant Type

Speed Twin

Triumph HD4X Hybrid OAT

Water/Coolant Ratio

50/50 (pre-mixed as supplied by Triumph)

Coolant Capacity

1.558 litres

Thermostat Opens

88°C +/- 2°C

Fuel System

Type

Speed Twin

Electronic fuel injection

Fuel Pump

Submerged electronic

Fuel Pressure (nominal)

3.5 bar

Specifications - Speed Twin

Fuel

Type
Tank Capacity

Speed Twin

91 RON unleaded
14.5 litres

Ignition

Ignition System
Spark Plug
Spark Plug Gap

Speed Twin

Digital inductive
NGK LMAR8A-9
0.9 mm +0.0/-0.1 mm

Transmission

Transmission Type
Clutch Type
Final Drive Chain
Primary Drive Ratio
Gear Ratio:

Speed Twin

6 speed, constant mesh
Wet, multiplate
EK 525 ZVX3, 102 link
93/74 (1.26)

1st

49/14 (3.5)

2nd

45/18 (2.5)

3rd

37/20 (1.85)

4th

37/25 (1.48)

5th

35/27 (1.3)

6th

34/29 (1.17)

Final Drive Ratio

42/16 (2.63)



Warning

Use the recommended tyres **ONLY** in the combinations given.

Do not mix tyres from different manufacturers or mix different specification tyres from the same manufacturers as this may result in loss of motorcycle control and an accident.

Approved Tyres

A list of approved tyres specific to these models is available from your authorised Triumph dealer, or on the Internet at www.triumph.co.uk.

Specifications - Speed Twin

Tyres

Tyre Sizes:

Front

120/70 R17

Rear

160/60 R17

Tyre Pressures (Cold):

Front

2.5 bar (36 lbs/in²)

Rear

2.9 bar (42 lbs/in²)

Electrical Equipment

Battery Type

YTZ10S

Battery Rating

12 Volt, 8.6 Ah

Alternator

25 Amps at 1,000 rpm

46.5 Amps at 3,000 rpm

Headlight

12 Volt, 60/55 Watt, H4 halogen

Tail/Brake Light

LED

Directional Indicator Lights

12 Volt, 10 Watt

License Plate Light

LED

Frame

Rake

22.8°

Trail

93.5 mm (3.7 in)

Tightening Torques

Battery Terminals

4.5 Nm

Chain Adjuster Lock Nuts

20 Nm

Chain Guard

9 Nm

Clutch Lever Nut

3.5 Nm

Oil Filter

10 Nm

Spark Plug

12 Nm

Sump Plug

25 Nm

Rear Wheel Spindle Nut

110 Nm

Specifications - Speed Twin

Fluids and Lubricants

Bearings and Pivots	Grease to NLGI 2 specification
Brake Fluid	DOT 4 brake fluid
Coolant	Triumph HD4X Hybrid OAT coolant (pre-mixed)
Drive Chain	Chain spray suitable for XW-ring chains Semi or fully synthetic 10W/40 or 10W/50 motorcycle engine oil which meets specification API SH (or higher) and JASO MA, such as Castrol Power 1 Racing 4T
Engine Oil	10W-40 (fully synthetic) engine oil, sold as Castrol Power RS Racing 4T 10W-40 (fully synthetic) in some countries.

Specifications - Street Twin

Dimensions, Weights and Performance

A list of model specific dimensions, weights and performance figures is available from your authorised Triumph dealer, or on the Internet at www.triumph.co.uk.

Payload

Maximum Payload

Street Twin

210 kg (463 lb)

Engine

Type

Street Twin

Liquid cooled parallel twin, 270° firing angle

Displacement

900 cc

Bore x Stroke

84.6 x 80 mm

Compression Ratio

11:1

Cylinder Numbering

Left to right

Cylinder Sequence

1-2

Firing Order

1-2

Starting System

Electric starter

Lubrication

Lubrication System

Street Twin

Wet sump

Engine Oil Capacities:

Dry Fill

3.8 litres

Oil/Filter Change

3.4 litres

Oil Change Only

3.2 litres

Cooling

Coolant Type

Street Twin

Triumph HD4X Hybrid OAT

Water/Coolant Ratio

50/50 (pre-mixed as supplied by Triumph)

Coolant Capacity

1.518 litres

Thermostat Opens

88°C +/- 2°C

Fuel System

Type

Street Twin

Electronic fuel injection

Fuel Pump

Submerged electronic

Fuel Pressure (nominal)

3.5 bar

Specifications - Street Twin

Fuel

Type
Tank Capacity

Street Twin

91 RON unleaded
12.0 litres

Ignition

Ignition System
Spark Plug
Spark Plug Gap

Street Twin

Digital inductive
NGK LMAR8A-9
0.9 mm +0.0/-0.1 mm

Transmission

Transmission Type
Clutch Type
Final Drive Chain
Primary Drive Ratio
Gear Ratio:

Street Twin

5 speed, constant mesh
Wet, multiplate
DID 520 VP2-T, 102 link
93/74 (1.26)

1st

49/14 (3.5)

2nd

45/18 (2.5)

3rd

37/20 (1.85)

4th

37/25 (1.48)

5th

35/27 (1.3)

Final Drive Ratio

41/17 (2.41)

Warning

Use the recommended tyres **ONLY** in the combinations given.

Do not mix tyres from different manufacturers or mix different specification tyres from the same manufacturers as this may result in loss of motorcycle control and an accident.

Approved Tyres

A list of approved tyres specific to these models is available from your authorised Triumph dealer, or on the Internet at www.triumph.co.uk.

Tyres

Tyre Sizes:

Front

100/90-18

Rear

150/70 R17

Specifications - Street Twin

Tyres

Tyre Pressures (Cold):

Front

2.2 bar (32 lbs/in²)

Rear

2.5 bar (36 lbs/in²)

Electrical Equipment

Battery Type

YTX12-BS

Battery Rating

12 Volt, 10 Ah

Alternator

25 Amps at 1,000 rpm

46.5 Amps at 3,000 rpm

Headlight

12 Volt, 60/55 Watt, H4 halogen

Tail/Brake Light

LED

Directional Indicator Lights

12 Volt, 10 Watt

License Plate Light

12 Volt, 5 Watt

Frame

Rake

25.1°

Trail

102.4 mm (4.03 in)

Tightening Torques

Battery Terminals

4.5 Nm

Chain Adjuster Lock Nuts

20 Nm

Chain Guard

9 Nm

Clutch Lever Nut

3.5 Nm

Oil Filter

10 Nm

Spark Plug

12 Nm

Sump Plug

25 Nm

Rear Wheel Spindle Nut

110 Nm

Specifications - Street Twin

Fluids and Lubricants

Bearings and Pivots	Grease to NLGI 2 specification
Brake Fluid	DOT 4 brake fluid
Coolant	Triumph HD4X Hybrid OAT coolant (pre-mixed)
Drive Chain	Chain spray suitable for XW-ring chains Semi or fully synthetic 10W/40 or 10W/50 motorcycle engine oil which meets specification API SH (or higher) and JASO MA, such as Castrol Power 1 Racing 4T 10W-40 (fully synthetic) engine oil, sold as Castrol Power RS Racing 4T 10W-40 (fully synthetic) in some countries.
Engine Oil	

Specifications - Thruxton and Thruxton R

Specifications - Thruxton and Thruxton R

Dimensions, Weights and Performance

A list of model specific dimensions, weights and performance figures is available from your authorised Triumph dealer, or on the Internet at www.triumph.co.uk.

Payload	Thruxton	Thruxton R
Maximum Payload	210 kg (463 lb)	210 kg (463 lb)
Engine	Thruxton	Thruxton R
Type	Liquid cooled parallel twin, 270° firing angle	Liquid cooled parallel twin, 270° firing angle
Displacement	1,200 cc	1,200 cc
Bore x Stroke	97.6 x 80 mm	97.6 x 80 mm
Compression Ratio	11:1	11:1
Cylinder Numbering	Left to right	Left to right
Cylinder Sequence	1-2	1-2
Firing Order	1-2	1-2
Starting System	Electric starter	Electric starter
Lubrication	Thruxton	Thruxton R
Lubrication System	Wet sump	Wet sump
Engine Oil Capacities:		
Dry Fill	3.8 litres	3.8 litres
Oil/Filter Change	3.4 litres	3.4 litres
Oil Change Only	3.2 litres	3.2 litres
Cooling	Thruxton	Thruxton R
Coolant Type	Triumph HD4X Hybrid OAT	Triumph HD4X Hybrid OAT
Water/Coolant Ratio	50/50 (pre-mixed as supplied by Triumph)	50/50 (pre-mixed as supplied by Triumph)
Coolant Capacity	1.558 litres	1.558 litres
Thermostat Opens	88°C +/- 2°C	88°C +/- 2°C
Fuel System	Thruxton	Thruxton R
Type	Electronic fuel injection	Electronic fuel injection
Fuel Pump	Submerged electronic	Submerged electronic
Fuel Pressure (nominal)	3.5 bar	3.5 bar

Specifications - Thruxton and Thruxton R

Fuel	Thruxton	Thruxton R
Type	91 RON unleaded	91 RON unleaded
Tank Capacity	14.0 litres	14.0 litres
Ignition	Thruxton	Thruxton R
Ignition System	Digital inductive	Digital inductive
Spark Plug	NGK LMAR8A-9	NGK LMAR8A-9
Spark Plug Gap	0.9 mm +0.0/-0.1 mm	0.9 mm +0.0/-0.1 mm
Transmission	Thruxton	Thruxton R
Transmission Type	6 speed, constant mesh	6 speed, constant mesh
Clutch Type	Wet, multiplate	Wet, multiplate
Final Drive Chain	EK 525 ZVX3, 100 link	EK 525 ZVX3, 100 link
Primary Drive Ratio	93/74 (1.26)	93/74 (1.26)
Gear Ratio:		
1st	49/14 (3.5)	49/14 (3.5)
2nd	45/18 (2.5)	45/18 (2.5)
3rd	37/20 (1.85)	37/20 (1.85)
4th	37/25 (1.48)	37/25 (1.48)
5th	35/27 (1.3)	35/27 (1.3)
6th	34/29 (1.17)	34/29 (1.17)
Final Drive Ratio	42/16 (2.63)	42/16 (2.63)

Warning

Use the recommended tyres **ONLY** in the combinations given.

Do not mix tyres from different manufacturers or mix different specification tyres from the same manufacturers as this may result in loss of motorcycle control and an accident.

Approved Tyres

A list of approved tyres specific to these models is available from your authorised Triumph dealer, or on the Internet at www.triumph.co.uk.

Specifications - Thruxton and Thruxton R

Tyres	Thruxton	Thruxton R
Tyre Sizes:		
Front	120/70 ZR17	120/70 ZR17
Rear	160/60 ZR17	160/60 ZR17
Tyre Pressures (Cold):		
Front	2.5 bar (36 lbs/in ²)	2.5 bar (36 lbs/in ²)
Rear	2.5 bar (36 lbs/in ²)	2.5 bar (36 lbs/in ²)
Electrical Equipment	Thruxton	Thruxton R
Battery Type	YTX12-BS	YTX12-BS
Battery Rating	12 Volt, 10 Ah	12 Volt, 10 Ah
Alternator	25 Amps at 1,000 rpm 46.5 Amps at 3,000 rpm	25 Amps at 1,000 rpm 46.5 Amps at 3,000 rpm
Headlight	12 Volt, 60/55 Watt, H4 halogen	12 Volt, 60/55 Watt, H4 halogen
Tail/Brake Light	LED	LED
Directional Indicator Lights	12 Volt, 10 Watt	12 Volt, 10 Watt
Frame	Thruxton	Thruxton R
Rake	22.6°	22.8°
Trail	90.8 mm (3.57 in)	92.1 mm (3.63 in)
Tightening Torques		
Battery Terminals	4.5 Nm	
Chain Adjuster Lock Nuts	20 Nm	
Chain Guard	9 Nm	
Clutch Lever Nut	3.5 Nm	
Oil Filter	10 Nm	
Spark Plug	12 Nm	
Sump Plug	25 Nm	
Rear Wheel Spindle Nut	110 Nm	

Specifications - Thruxton and Thruxton R

Fluids and Lubricants

Bearings and Pivots	Grease to NLGI 2 specification
Brake Fluid	DOT 4 brake fluid
Coolant	Triumph HD4X Hybrid OAT coolant (pre-mixed)
Drive Chain	Chain spray suitable for XW-ring chains Semi or fully synthetic 10W/40 or 10W/50 motorcycle engine oil which meets specification API SH (or higher) and JASO MA, such as Castrol Power 1 Racing 4T 10W-40 (fully synthetic) engine oil, sold as Castrol Power RS Racing 4T 10W-40 (fully synthetic) in some countries.
Engine Oil	

Index

- A**
- Accessories..... 93
 - Anti-Lock Brake System (ABS)
 - Disable..... 51
 - Enable..... 51
 - Anti-Lock Braking System (ABS)..... 86
 - Indicator Light..... 37
- B**
- Bank Angle Indicators..... 132
 - Battery..... 138
 - Charging..... 141
 - Discharge..... 140
 - Disposal..... 139
 - Installation..... 141, 142
 - Maintenance..... 139
 - Removal..... 138, 139
 - Storage..... 140
 - Brakes
 - Anti-Lock Braking System (ABS)..... 86
 - Brake Lever Adjuster..... 63
 - Brake Wear Inspection..... 117
 - Braking..... 84
 - Breaking in New Pads and Discs..... 117
 - Disc Brake Fluid..... 119
 - Front Fluid Inspection and Adjustment..... 119
 - Light Switches..... 122
 - Pad Wear Compensation..... 118
 - Rear Fluid Inspection and Adjustment..... 121
- C**
- Cleaning
 - After Washing..... 152
 - Aluminium Items - not Lacquered or Painted..... 152
 - Black Chrome Items..... 153
 - Care of Leather Products..... 156
 - Chrome and Stainless Steel..... 153
 - Drying..... 154
 - Exhaust System..... 154
 - Frequency of Cleaning..... 150
 - Gloss Paintwork..... 152
 - Matt Paintwork..... 152
 - Preparation for Washing..... 150
 - Protecting..... 154
 - Seat Care..... 155
 - Washing..... 151
 - Washing the Exhaust..... 154
 - Where to be Careful..... 151
 - Windscreen..... 155
- D**
- Clock..... 45
 - Adjustment..... 45
 - Clutch..... 111
 - Adjustment..... 112
 - Inspection..... 111
 - Clutch Lever
 - Adjustment..... 62
 - Cooling System..... 107
 - Coolant Change..... 109
 - Coolant Level Inspection..... 108
 - Corrosion Inhibitors..... 107
 - High Coolant Temperature Warning Light..... 36
 - Level Adjustment..... 109
 - Specifications..... 159, 163, 167, 171, 175, 179
- D**
- Daily Safety Checks..... 77
 - Daytime Running Lights (DRL)..... 39
 - Direction Indicator Lights
 - Bulb Replacement..... 147
 - LED Lights..... 147
 - Direction Indicators
 - Warning Light..... 38
 - Drive Chain..... 113
 - Lubrication..... 113
 - Movement Adjustment..... 114
 - Movement Inspection..... 114
 - Wear Inspection..... 116
- E**
- Electrical Equipment
 - Specifications..... 161, 165, 169, 173, 177, 181

Index

- Engine
Moving Off..... 82
Serial Number..... 29
Specifications..... 159, 163, 167, 171, 175, 179
Starting the Engine..... 82
Stopping the Engine..... 81
- Engine Oil..... 103
Disposal of Oil and Filters..... 106
Level Inspection..... 104
Low Oil Pressure Warning Light..... 36
Oil Filter Change..... 104
Specification and Grade..... 106
- Engine Start/Stop Switch
RUN Position..... 57
START Position..... 57
STOP Position..... 57
- F**
- Fluids
Specifications..... 162, 166, 170, 174, 178, 182
- Frame
Specifications..... 161, 165, 169, 173, 177, 181
- Fuel
Filling the Fuel Tank..... 66
Fuel Grade..... 64
Fuel Tank Cap..... 65
Low Fuel Indicator Light..... 39
Refuelling..... 65
Specifications..... 160, 164, 168, 172, 176, 180
System Specifications 159, 163, 167, 171, 175, 179
- Fuses
Fuse Box Location..... 142
Fuse Identification..... 143
- G**
- Gears
Changing..... 83
- H**
- Hazards
Warning Lights..... 57
- Headlights..... 144
Adjustment..... 146
Bulb Replacement..... 144
- Heated Grips..... 60
- Helmet Hook..... 71
- High Beam
Indicator Light..... 59
- High Speed Operation..... 90
- I**
- Ignition
Ignition Key..... 55
Ignition Switch/Steering Lock..... 55
Immobiliser..... 55
Key..... 55
Specifications..... 160, 164, 168, 172, 176, 180
- Immobiliser
Indicator Light..... 37
- Instruments
Average Fuel Consumption..... 43
Clock..... 45
Fuel Gauge..... 42
Gear Position Display..... 41
Instrument Panel Layout..... 34
Range to Empty..... 42
Speedometer..... 41
Tachometer..... 41
Trip Meter..... 44
- L**
- Left Handlebar Switches..... 58
Daytime Running Light Switch..... 59
Direction Indicator Switch..... 59
Horn Button..... 58
SCROLL Button..... 58
- License Plate Light..... 148
Bulb Replacement..... 148
- Loading..... 94
- Lubrication
Specifications..... 159, 163, 167, 171, 175, 179
- M**
- Maintenance
Scheduled Maintenance..... 99
- Mirrors..... 122
Bar End Mirrors..... 123
- MODE Button..... 57, 59
-

-
- Multifunctional Rear Lights..... 146
- O**
- Owner's Handbook..... 70
- P**
- Parking..... 88
- Parts Identification..... 16, 18, 20, 22, 24
- Rider View..... 26, 27
- Passengers..... 95
- Payload
- Specifications..... 159, 163, 167, 171, 175, 179
- R**
- Rear Light..... 146
- Riding Modes..... 46
- Selecting When Riding the Motorcycle..... 48
- Selecting When the Motorcycle is Stationary..... 47
- Right Handlebar Switches..... 56
- Running-In..... 76
- S**
- Safety
- Fuel and Exhaust Fumes..... 8
- Handlebars and Footrests..... 12
- Helmet and Clothing..... 9
- Maintenance and Equipment..... 10
- Motorcycle..... 7
- Parking..... 9
- Parts and Accessories..... 10
- Riding..... 11
- Seats
- Installation..... 72
- Passenger Seat Installation..... 73
- Passenger Seat Removal..... 73
- Removal..... 72
- Rider's Seat Installation..... 73
- Rider's Seat Removal..... 73
- Seat Care..... 71, 155
- Seat Lock..... 72
- Side Panels..... 68
- Refit..... 69
- Removal..... 68, 69
- Specifications
- Bonneville T100, Bonneville T120..... 159, 163
- Speed Twin..... 171
- Street Scrambler..... 167
- Street Twin..... 175
- Thruxton, Thruxton R..... 179
- Stand
- Centre Stand..... 68
- Side Stand..... 67
- Steering
- Inspection..... 124
- Storage
- Preparation after Storage..... 158
- Preparation for Storage..... 157
- Suspension
- Front Adjustment..... 126
- Front Compression Damping Adjustment..... 127
- Front Fork Inspection..... 128
- Front Preload Adjustment..... 127
- Front Rebound Damping Adjustment..... 127
- Front Settings..... 126
- Rear Compression Damping Adjustment..... 131
- Rear Preload Adjustment..... 130
- Rear Rebound Damping Adjustment..... 131
- Rear Settings..... 129
- T**
- Throttle Control..... 61, 110
- Inspection..... 110
- Tool Kit..... 70
- Torque Specifications..... 161, 165, 169, 173, 177, 181
- Traction Control (TC)..... 49
- Disable..... 50
- Disabled Warning Light..... 38
- Indicator Light..... 38
- Settings..... 50
- Transmission
- Specifications..... 160, 164, 168, 172, 176, 180
- Tyre Pressure Monitoring System (TPMS)..... 52
- Replacement Tyres..... 54
- Sensor Serial Number..... 52
- Tyre Pressures..... 134
-

Index

Tyres.....	4
Minimum Tread Depth.....	135
Replacement.....	54, 135
Specifications.....	161, 165, 168, 173, 176, 181
Tyre Inflation Pressures.....	133
Tyre Wear.....	134

U

Universal Serial Bus (USB) Socket.....	76
--	----

V

Vehicle Identification Number (VIN).....	29
--	----

W

Warnings.....	3
Immobiliser and TPMS.....	4
Maintenance.....	3
Noise Control System.....	3
Owner's Handbook.....	5
Warning Label Locations.....	14, 15
Warning Labels.....	3
Warning Lights.....	36
Wheel Bearings	
Inspection.....	125

Approval Information

This section contains approval information that is required to be included in this Owner's Handbook.

Radio Equipment Device EU Directive 2014/53

Triumph motorcycles are equipped with a range of radio equipment devices. These radio equipment devices must comply with the EU Radio Equipment Device Directive 2014/53/EU. The complete text of the EU declaration of conformity for each radio equipment device is available at the following address:

www.triumphmotorcycles.co.uk/public-content/triumph-radio-device-approvals

Approval Information

The table below shows the frequencies and power levels for the radio equipment devices in compliance with the EU Directive 2014/53/EU. The table shows all radio equipment devices used across the Triumph range of motorcycles. Only certain radio equipment devices in the table are applicable to specific motorcycles.

Radio Equipment Device	Frequency Range	Maximum Transmit Power Level	Manufacturer
Chassis Control Unit	Receive Bands: 433.92 MHz, 134.2 kHz Category-2 Receiver Transmit Bands: 134.2 kHz Class 1 Transmitter Fixed Inductive Loop Coil Antenna	287 nW ERP	Pektron Alfreton Road, Derby, DE21 4AP UK
Keyless Control Unit	Receive Bands: 433.92 MHz, 134.2 kHz Category-2 Receiver Transmit Bands: 134.2 kHz Class 1 Transmitter Fixed Inductive Loop Coil Antenna	6.28 uW ERP	
Keyless Control Unit 2	Receive Bands: 433.92 MHz, 134.2 kHz Category-2 Receiver Transmit Bands: 134.2 kHz Class 1 Transmitter Fixed Inductive Loop Coil Antennas	3.01 uW ERP	
Keyless System Key Fob	Receive Bands: 134.2 kHz Category-2 Receiver Transmit Bands: 433.92 MHz, 134.2 kHz Class: N/A Antenna Type Fixed Antenna (PCB)	0.019 mW ERP	

Approval Information

Radio Equipment Device	Frequency Range	Maximum Transmit Power Level	Manufacturer
Immobiliser (Motorcycles with Key System)	Receive Bands: 433.92 MHz, 125 kHz Transmit Bands: 120.9 KHz to 131.3 KHz	5dB A/m @ 10m	LDL Technology Parc Technologique Du Canal,
Tyre Pressure Monitoring System (TPMS)	Receive Bands: None Transmit Bands: 433.97 MHz to 433.87 MHz	0.063 mW	3 Rue Giotto, 31520 Ramonville Saint-Agne, France
Triumph Accessory Alarm System ECU	Receive Bands: 433.92 MHz Transmit Bands: None	N/A	Scorpion Automotive Ltd Drumhead Road,
Triumph Accessory Alarm System Remote/Key Fob	Receive Bands: None Transmit Bands: 433.92 MHz	10 mW ERP	Chorley North Business Park, Chorley, PR6 7DE UK

Representative within the European Union

Address

Triumph Motocicletas Espana S.L.
C/Cabo Rufino Lazaro
14 - E
28232 - Las Rozas De Madrid
Spain

Approval Information

This page intentionally left blank