

## RPZ211V230

Ballast Type: Electronic  
 Input Voltage: 230Vac ±10%  
 Input Frequency: 47-63Hz

Starting Method: Preheat Rapid Start  
 Lamp Connection: Series

Unit Color: Galvanneal  
 Unit Weight: 0.33 lbs.

### ELECTRICAL SPECIFICATIONS:

Line Voltage (V)	No. of Lamps	Lamp Type	Typical Lamp Watts (W)	Lamp Voltage (V)	Lamp Current (mA)	Input Current (A)	Input Power (W)	Input Current THD (%)	Lamp Current Crest Factor	Electrical Efficiency
207	2	Actinic BL PL-S 9W	9	50	154	0.15	16.9	120	1.56	0.90
230				47	181	0.16	19.2	124	1.58	0.89
253				45	210	0.16	21.6	127	1.60	0.87
207	2	TUV PL-S 9W/4P	9	50	154	0.15	16.9	120	1.56	0.90
230				47	181	0.16	19.2	124	1.58	0.89
253				45	210	0.16	21.6	127	1.60	0.87
207	2	HNS S 9 W G23 (GCF9DS/G23/SE/OF)	9	50	154	0.15	16.9	120	1.56	0.90
230				47	181	0.16	19.2	124	1.58	0.89
253				45	210	0.16	21.6	127	1.60	0.87
207	2	HNS S/E 9W 2G7	9	55	122	0.14	15.6	122	1.52	0.84
230				52	151	0.15	17.9	151	1.56	0.85
253				49	188	0.16	20.5	188	1.61	0.87
207	2	HNS S 11 W G23 (GCF11DS/G23/SE/OF)	11	76	151	0.20	24.2	105	1.59	0.95
230				74	168	0.21	27.0	110	1.49	0.92
253				71	188	0.21	29.8	114	1.58	0.91
207	2	HNS S/E 11W 2G7	11	85	110	0.18	22.3	108	1.44	0.84
230				84	121	0.19	24.8	112	1.52	0.82
253				77	144	0.20	27.6	116	1.52	0.81

### PERFORMANCE:

- Power Factor = >0.50
- Encased & Potted
- Sound Rated A
- Internal Surge Protection
- Meets FCC Part 18 (Class B) for EMI and RFI Consumer Limits
- Meets ANSI Standard C62.41 for Transient Protection
- Meets ANSI Standard C82.11 for Ballast Requirements

### APPLICATION:

- Maximum Case Temperature: 167°F/75°C
- Maximum Ambient Temperature: 122°F/50°C
- Minimum Starting Temperature: 23°F/-5°C
- Remote Mounting: 18 ft. Max. Lead Length, 18AWG

### SAFETY/STANDARDS:

- UL/935 Listed (Class P, Type 1 Outdoor)
- cUL (CSA/C22.2 Certified)
- No PCBs, Type HL, Type CC
- Inherent Thermal Protection
- RoHS Compliant

### CASE STYLE: CS-3C

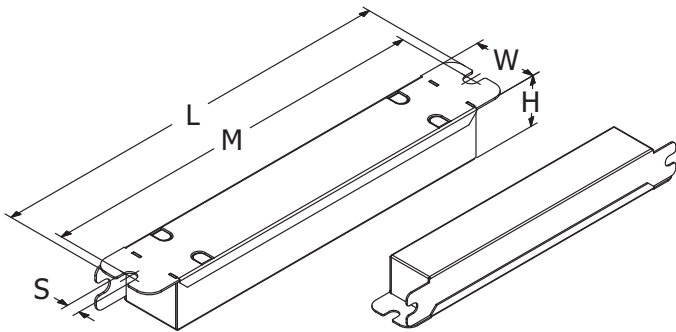

L	W	H	M	S
5-29/32	7/8	3/4	5-5/8	3/16
5.91	0.91	0.75	5.63	0.19
15.00 cm	2.30 cm	1.91 cm	14.29 cm	0.48 cm

### WIRING DIAGRAM: WD-116

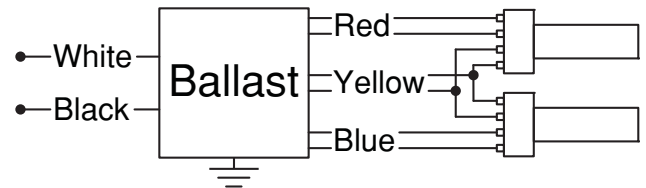

- Black: 12"
- White: 12"
- Tolerance: +1.00, -0.50"
- Strip: 0.375" ± 0.060"
- Red: (2) 12"
- Blue: (2) 12"
- Yellow: (2) 12"
- Tolerance: +1.00, -0.50"
- Strip: 0.375" ± 0.060"

### WARRANTY:

Robertson Worldwide warrants to the purchaser that this product will be free from defects in material or workmanship for a period of 2 years from date of manufacture when properly installed and under normal condition of use. Specifications subject to change without notice.

For more information on Robertson Worldwide products, visit [www.RobertsonLighting.com](http://www.RobertsonLighting.com)