



METAL HALIDE LAMPS

MHR SERIES



METAL HALIDE WITH REFLECTOR FOR FIBER OPTIC APPLICATIONS

The MHR series was specifically designed for fiber optic and light pipe applications. These lamps are predominantly used in applications with a fiber diameter of more than 8mm at the input and offers an unproblematic operation with standard ballasts and thus lowers cost applications.

The MHR series features an ellipsoidal reflector coated with a special dichroic coating which transmits most of the lamp's heat radiation toward the rear.

Specifications include a 6.5mm arc gap, total luminous efficacy of 85 lumens per watt and useful lamp life of up to 6000 hours. The MHR series is an economical solution to high development and maintenance costs associated with using lamps developed for applications other than fiber

FEATURES AND BENEFITS

- MHR-100D/L, MHR-100D/HR uses M90 Ballast or Electronic Equivalent, MHR-150N uses M81 Ballast and MHR-250N uses M80 Ballast
- Cold Mirror Reflector- concise front end
- Compact Design
- Aligned to a fiber during manufacturing
- Standardized AMP Connector

Watts (W)	Ushio Ordering Code	Ushio Lamp Code	Voltage (V)	Ignition Voltage (kV)	Lamp Current (A)	Luminous Flux through Aperature			Color Temp (K)	CRI	Avg Life (h)
						$\phi 13\text{mm}$ distance 42mm (lm*)	$\phi 10\text{mm}$ distance 44mm (lm*)	$\phi 25\text{mm}$ distance 33mm (lm**)			
100	5000789	MHR-100D/L	95	4	1.2	1600	1800	4600	5200	72	6000
100	5000790	MHR-100D/HR	95	4	1.2	1600	1800	4600	5200	72	6000
150	5000834	MHR-150N	95	4	1.8	2000	2200	5300	4200	75	6000
250	5001377	MHR-250N	100	4	3.0	3500 [▲]	—	—	4200	72	4000

Distributed by:

- * Measurement taken with optical sphere
- ** Measurement taken through fiber bundle
- ▲ ($\phi 13\text{mm}$; distance 53mm)

Form No. S-MHR/R-0907: The specifications on this sheet supercede all previously published specifications and may be subject to change for design and specification improvement without prior notice.

USHIO

CHARACTERISTICS & SPECIFICATIONS

MHR-100D, MHR-100D/HR, MHR-150N, MHR-250N

Application Hints

The optimal focal distance between the lamp and the fibre depends on the diameter of the fibre. A rough calculation of the optimal distance between lamp and fixture can be done by the following formula:

$$\begin{array}{l} 100/150W \quad Fd = 52mm - D * 0.77 \\ 250W \quad \quad Fd = 64mm - D * 0.77 \end{array}$$

Fd(mm): Optimal distance between fiber and lamp
D(mm): Diameter of the fiber bundle

UV and IR radiation from the lamp may cause damage to synthetic fibers. Therefore, reflective or absorbing filters are recommended for use with synthetic fibers.

Optimal distance: 100W & 150W 250W from reflector to fiber:	42mm 53mm (with ø13mm fiber bundle)
Length of Base Lead Wire:	Approx. 75mm
Base Type: MHR-100D/L MHR-100D/HR MHR-150N MHR-250N	AMP Universal Mate-N-Lok 3 channel plug 5 channel plug 5 channel plug 5 channel plug

Burn Position: Lead wire facing up

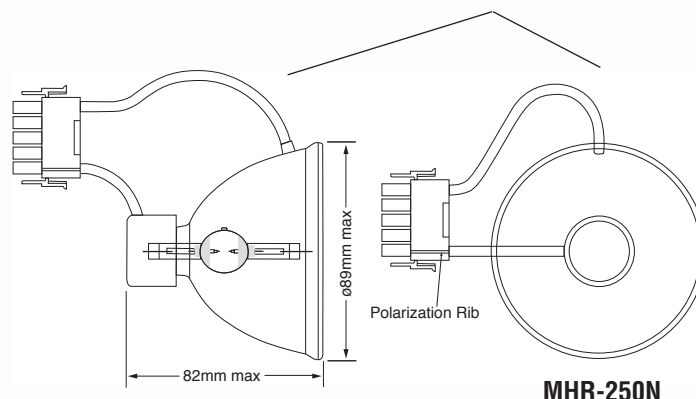
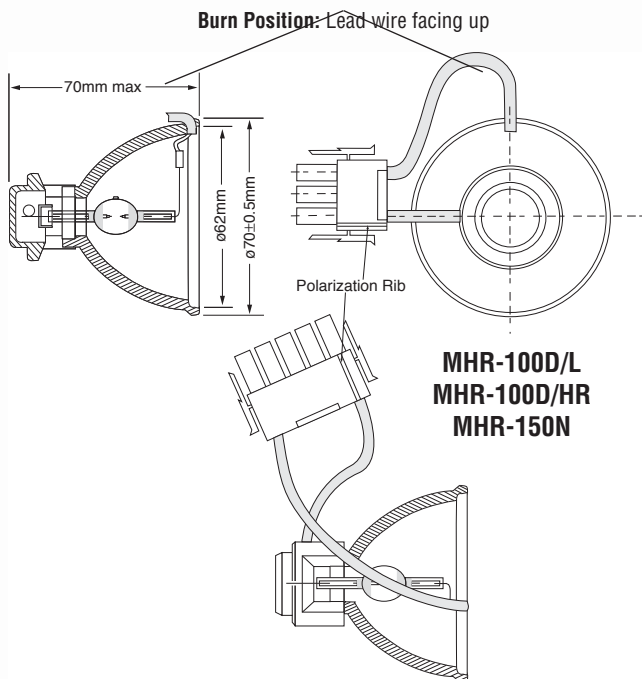

Ballast & Ignitor Information

100W lamp—M90; 150W lamp—M81; 250W lamp—M80

At the end of their lifetime, metal halide lamps may show rectifier effects causing a rise in current of up to 3 times of the rated value thereby possibly damaging the ballast. Therefore we recommend to use only ballasts with integrated thermostats. For line compensation, a capacitor should be used. It is recommended to use ignitors with a timer switch. The use of electronic ballasts is possible if the operating frequency is below 250Hz. All lamps must be used with 4kV ignitor.

MHR-100D/L

Warm-up Time to 95% luminous flux: 2.5 minutes with standard ballast

Reignition Time: Approximately 1 minute

MHR-100D/HR

Warm-up Time to 95% luminous flux: 2.5 minutes with standard ballast

Hot re-strike version

MHR-150N

Warm-up Time: 3 minutes

Reignition Time: Approximately 2 minutes

Warning

The lamp emits UV radiation which can cause serious eye and skin damage. Therefore, the lamp must be used only in closed lamp houses.

SPECTRAL DISTRIBUTION CURVE

