

70 Watt Pulse Start Metal Halide Lamp (Clear)

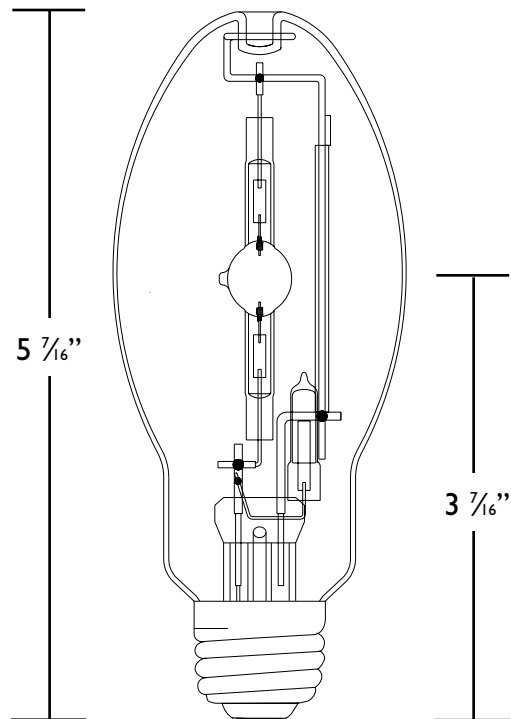

Ordering Information

Ordering Code	MH70/U/M/PS 24Pk
ANSI Designation	M98/E
Product Number	137505
Description	Metal Halide - Pulse Start
Package Quantity	24

Physical Characteristics

Bulb Size	BD-17
Bulb Finish	Clear
Base	Medium
Max. Overall Length (MOL)	5 7/16" (138mm)
Light Center Length (LCL)	3 7/16" (86mm)
Arc Length	0.34" (9mm)
Arc Tube Material	Quartz
Max. Permissible Bulb Temp.	400°C (752°F) ANSI
Max. Permissible Base Temp.	190°C (374°F) ANSI
Max. Bulb to Base Eccentricity	3°
Max. Arc Tube to Base Eccentricity	3°

Operating Characteristics (Photometric)

Rated Initial Lumens ¹	5,500
Mean Lumens, Approx. ²	3,300
Rated Average Life, Hours	12,000
Correlated Color Temp. (CCT) ²	4000K
CIE Chromaticity Approx. ²	x-0.385, y-0.390
Color Rendering Index (CRI)	60
Efficacy (lpw)	79
Lumen Maintenance @ 40% rated life	60%

Operating Position

Universal

Note: Pulse Start Metal Halide is Designed for Operation on Only Approved Ballasts with Metal Halide Pulse Ignitors.

PHILIPS

Philips Lighting Company
200 Franklin Square Drive
Somerset, NJ 08873
1-800-555-0050

www.philips.com

Philips Lighting
281 Hillmount Road
Markham, Ontario
Canada L6C 2S3
1-800-555-0050
A Division of Philips Electronics Ltd.

A Division of Philips Electronics North America Corporation

Updated 11/10

TDS-137505

70 Watt Pulse Start Metal Halide Lamp (Clear) Technical Data Sheet

Electrical Data (Subject to change without notice)

Lamp Watts (Nominal)	70W
Lamp Operating Voltage (rms) (Nominal) ²	85V
Initial Lamp Voltage Range (rms) ³	75V-100V
Lamp Operating Current (Amps) (rms) (Nominal)	0.9
Maximum Lamp Starting Current (Amps)(rms)	1.5
Lamp Current Crest Factor (Maximum)	1.8
Warm-up Time to 95% minimum lamp operating voltage ²	2 Minutes
Re-strike Time for Hot Lamp	10 Minutes
Ballast Type	ANSI M98/E
Ignition Pulse	3000V min.; 4000V max.
Pulse Width @ 2700Volts	1.9µ (micro sec.)
Pulse Repetition Rate (Minimum)	1 per Half Cycle
Starting Ballast Open Circuit Voltage (Minimum):	235 Vrms
@10°C for 10 seconds-98 % of "0"hr lamps start	
@-30°C for 120 seconds-90% of 100 hr lamps start	
Minimum Operating Temperature	-30°C
Reference Ballast Impedance	188 (ohms)
Maximum Lamp Watts	84 watts
Rated input voltage	220 volts

1) Measured at 100 hrs of life in vertical position.

2) Measured at rated lamp watts on a linear reactor. LPW does not include ballast losses.

3) Measured with the lamp operating at rated watts.

Warnings, Cautions and Operating Instructions

R

“WARNING: These lamps can cause serious skin burn and eye inflammation from short wave ultraviolet radiation if outer envelope of the lamp is broken or punctured. Do not use where people will remain for more than a few minutes unless adequate shielding or other safety precautions are used. Certain lamps that will automatically extinguish when the outer envelope is broken or punctured are commercially available.” This lamp complies with FDA radiation performance standard 21 CFR subchapter J. (USA:21CFR 1040.30 Canada: SOR/DORS/80-381)

If the outer bulb is broken or punctured, turn off at once and replace the lamp to avoid possible injury from hazardous short wave ultraviolet radiation. Do not scratch the outer bulb or subject it to pressure as this could cause the outer bulb to crack or shatter. A partial vacuum in the outer bulb may cause glass to fly if the envelope is struck.

WARNING: The arc-tube of metal halide lamps are designed to operate under high pressure and at temperatures up to 1000°C and can unexpectedly rupture due to internal or external factors such as a ballast failure or misapplication. If the arc-tube ruptures for any reason, the outer bulb may break and pieces of extremely hot glass might be discharged into the surrounding environment. If such a rupture were to happen, **THERE IS A RISK OF PERSONAL INJURY, PROPERTY DAMAGE, BURNS AND FIRE.**

Certain lamps that will retain all the glass particles should inner arc-tube rupture occur are commercially available from Philips Lighting Company.

RELAMP FIXTURES AT OR BEFORE THE END OF RATED LIFE.

Allowing lamps to operate until they fail is not advised and may increase the possibility of inner arc tube rupture.

WARNING: Caution. UV emitted from this lamp. Minimize exposure. Shielding lamps via glass or plastic normally produces adequate protection.

CAUTION: TO REDUCE THE RISK OF PERSONAL INJURY, PROPERTY DAMAGE, BURNS AND FIRE RESULTING FROM AN ARC-TUBE RUPTURE THE FOLLOWING LAMP OPERATING INSTRUCTIONS MUST BE FOLLOWED.

Lamp Operating Instructions:

- 1) Turn off lamps at least once a week for at least 15 minutes in systems, which are operating on a continuous basis (24 hours/day-7days/week). FAILURE TO TURN OFF LAMPS FOR THE MINIMUM RECOMMENDED TIME MAY INCREASE THE POSSIBILITY OF AN INNER ARC-TUBE RUPTURE
- 2) RELAMP FIXTURES AT OR BEFORE THE END OF RATED LIFE. Allowing lamps to operate until they fail is not advised and may increase the possibility of inner arc tube rupture.
- 3) Use only in an enclosed fixture capable of withstanding particles of glass having temperatures up to 1000°C, unless otherwise noted.
- 4) Before lamp installation/replacement, shut power off and allow lamp and fixture to cool to avoid electrical shock and potential burn hazards.
- 5) Use only auxiliary equipment meeting Philips and/or ANSI standards. Use within voltage limits recommended by ballast manufacturer.
 - A. Operate lamp only within specified limits of operation.
 - B. For total supply load refer to ballast manufacturers electrical data.
 - C. All Pulse Start medium based lamps require a socket rated to withstand a 4000 Volt pulse.
- 6) Periodically inspect the outer envelope. Replace any lamps that show scratches, cracks or damage
- 7) If a lamp bulb support is used, be sure to insulate the support electrically to avoid possible decomposition of the bulb glass
- 8) Protect lamp base, socket and wiring against moisture, corrosive atmospheres and excessive heat.
- 9) Time should be allowed for lamps to stabilize in color when turned on for the first time. This may require several hours of operation, with more than one start. Lamp color is also subject to change under conditions of excess vibration or shock, and color appearance may vary between individual lamps.
- 10) Lamps may require 10 to 20 minutes to re-light if there is a power interruption
- 11) Take care in handling and disposing of lamps. If an arc tube is broken, avoid skin contact with any of the contents or fragments.
- 12) Use this lamp only in a fixture that contains a Pulse Start metal halide ballast and is specifically designed for use with Pulse Start metal halide lamps.

