



YJ-VTC-5730-G01

High CRI LED

PRODUCT:

5730 SURFACE MOUNT LED VTC

FEATURES:

5.7 mm × 3.0 mm × 0.8 mm surface-mount LED
 120° emission angle
 95 min Ra



DESCRIPTION

Yuji LED's VTC 5730 SMD provides true full spectrum coverage and ultra high CRI using violet die technology. Providing 98 CRI (typical), this mid-power LED can be used in a variety of applications demanding high color quality and performance.



ELECTRICAL-OPTICAL CHARACTERISTICS (T _c = 25 °C)							
PARAMETER	SYMBOL	VALUE			UNIT	TOLERANCE	CONDITION
		MIN.	TYP.	MAX.			
Forward Voltage	V _f	3.1	--	3.7	V	±0.05	I _f =120mA
Luminous flux	Φ _{2700K}	23	--	27	lm	--	I _f =120mA
	Φ _{3200K}	24		29			
	Φ _{4000K}	25		30			
	Φ _{5000K}	27		32			
	Φ _{5600K}	27		32			
	Φ _{6500K}	27		32			
Color temperature	CCT _{2700K}	2550	2700	2850	K	--	I _f =120mA
	CCT _{3200K}	3050	3200	3350			
	CCT _{4000K}	3800	4000	4200			
	CCT _{5000K}	4700	5000	5300			
	CCT _{5600K}	5300	5600	5900			
	CCT _{6500K}	6000	6500	7000			
Color rendering index	R _a	95	98	--	--	±1	I _f =120mA
TCS R9 (CRI Red)	R ₉	--	90	--	--	--	I _f =120mA
Chromaticity coordinates	(X,Y)	--	--	--	--	±0.005	--
Reverse Current	I _r	--	--	10	μA	±0.1	V _r =5V
Viewing angle	2θ _{1/2}	--	120	--	Deg	±5	I _f =120mA
Thermal resistance	R _{θJS} *	--	23	--	°C/W	--	I _f =120mA

*This data is for reference only.



YJ-VTC-5730-G01

High CRI LED

ORDERING INFORMATION			
PART NUMBER	CCT	CHROMATICITY BINS	VOLTAGE RANGE
YJ-VTC-5730-G01-27	2700K ± 150K	VF4-7, VF5-8, VF7-10, VF8-11	0.1 V
YJ-VTC-5730-G01-32	3200K ± 150K	VF4-2, VF7-2, VF5-1, VF8-1	0.1 V
YJ-VTC-5730-G01-40	4000K ± 200K	VD4-1, VD4-2, VD6-1, VD6-2	0.1 V
YJ-VTC-5730-G01-50	5000K ± 250K	VC3-2, VC4-1, VC5-2, VC6-1	0.1V
YJ-VTC-5730-G01-56	5600K ± 300K	VB8-2, VB10-2, VC3-1, VC5-1	0.1 V
YJ-VTC-5730-G01-65	6500K ± 500K	VB7-1, VB7-2, VB8-1, VB9-1, VB9-2, VB10-1	0.1V
YJ-VTC-5730-G01-XX	CUSTOM		

VOLTAGE BIN CODES						
Bin	V31	V32	V33	V34	V35	V36
V _F	3.1-3.2	3.2-3.3	3.3-3.4	3.4-3.5	3.5-3.6	3.6-3.7

ABSOLUTE MAXIMUM RATING (T _c = 25 °C)			
PARAMETER	SYMBOL	LIMIT	UNIT
Power Consumption	P _D	510	mW
DC Forward Current (pulsed)*	I _{Fp}	300**	mA
DC Forward Current	I _F	150	mA
Reverse Voltage	V _R	5	V
Junction Temperature	T _j	150	°C
Solder Point Temperature***	T _s	105	°C
Operating Temperature	T _{opr}	-40 ~ +85	°C
Storage Temperature	T _{stg}	-30 ~ +100	°C
Soldering Temperature	T _{sol}	260 ± 5	°C
Reflow Cycles Allowed	--	2	--

* Pulse width ≤ 0.1ms, Duty ≤ 1/10.

** Theoretical data.

*** See page 4 for solder point definition.



CHROMATICITY BINS & COORDINATES									
CCT	BIN	CIE 1931 COORDINATES							
		X0	Y0	X1	Y1	X2	Y2	X3	Y3
6500K	VB7-1	0.3030	0.3300	0.3057	0.3190	0.3118	0.3257	0.3097	0.3375
	VB7-2	0.3097	0.3375	0.3118	0.3257	0.3178	0.3325	0.3165	0.3450
	VB8-1	0.3165	0.3450	0.3178	0.3325	0.3239	0.3392	0.3233	0.3525
	VB9-1	0.3057	0.3190	0.3083	0.3080	0.3137	0.3140	0.3118	0.3257
	VB9-2	0.3118	0.3257	0.3137	0.3140	0.3192	0.3200	0.3178	0.3325
	VB10-1	0.3178	0.3325	0.3192	0.3200	0.3246	0.3260	0.3239	0.3392
5600K	VB8-2	0.3233	0.3525	0.3300	0.3600	0.3300	0.3460	0.3239	0.3392
	VB10-2	0.3239	0.3392	0.3246	0.3260	0.3300	0.3320	0.3300	0.3460
	VC3-1	0.3300	0.3460	0.3300	0.3600	0.3377	0.3662	0.3372	0.3520
	VC5-1	0.3300	0.3320	0.3300	0.3460	0.3372	0.3520	0.3366	0.3379
5000K	VC3-2	0.3372	0.3520	0.3377	0.3662	0.3455	0.3725	0.3443	0.3581
	VC4-1	0.3443	0.3581	0.3455	0.3725	0.3532	0.3788	0.3515	0.3642
	VC5-2	0.3366	0.3379	0.3372	0.3520	0.3443	0.3581	0.3432	0.3439
	VC6-1	0.3432	0.3439	0.3443	0.3581	0.3515	0.3642	0.3499	0.3497
4000K	VD4-1	0.3742	0.3808	0.3780	0.3970	0.3884	0.4050	0.3837	0.3870
	VD4-2	0.3837	0.3870	0.3884	0.4050	0.3988	0.4116	0.3932	0.3937
	VD6-1	0.3705	0.3646	0.3742	0.3808	0.3837	0.3870	0.3791	0.3705
	VD6-2	0.3791	0.3705	0.3837	0.3870	0.3932	0.3937	0.3878	0.3759
3200K	VF4-2	0.4237	0.4160	0.4158	0.3969	0.4259	0.4017	0.4346	0.4213
	VF7-2	0.4158	0.3969	0.4081	0.3779	0.4173	0.3822	0.4259	0.4017
	VF5-1	0.4346	0.4213	0.4259	0.4017	0.4388	0.4051	0.4486	0.4249
	VF8-1	0.4259	0.4017	0.4173	0.3822	0.4291	0.3853	0.4388	0.4051
2700K	VF4-7	0.4502	0.4226	0.4649	0.4252	0.4567	0.4083	0.4415	0.4059
	VF5-8	0.4649	0.4252	0.4822	0.4277	0.4729	0.4107	0.4567	0.4083
	VF7-10	0.4415	0.4059	0.4567	0.4083	0.4486	0.3915	0.4328	0.3899
	VF8-11	0.4567	0.4083	0.4729	0.4107	0.4636	0.3938	0.4486	0.3915

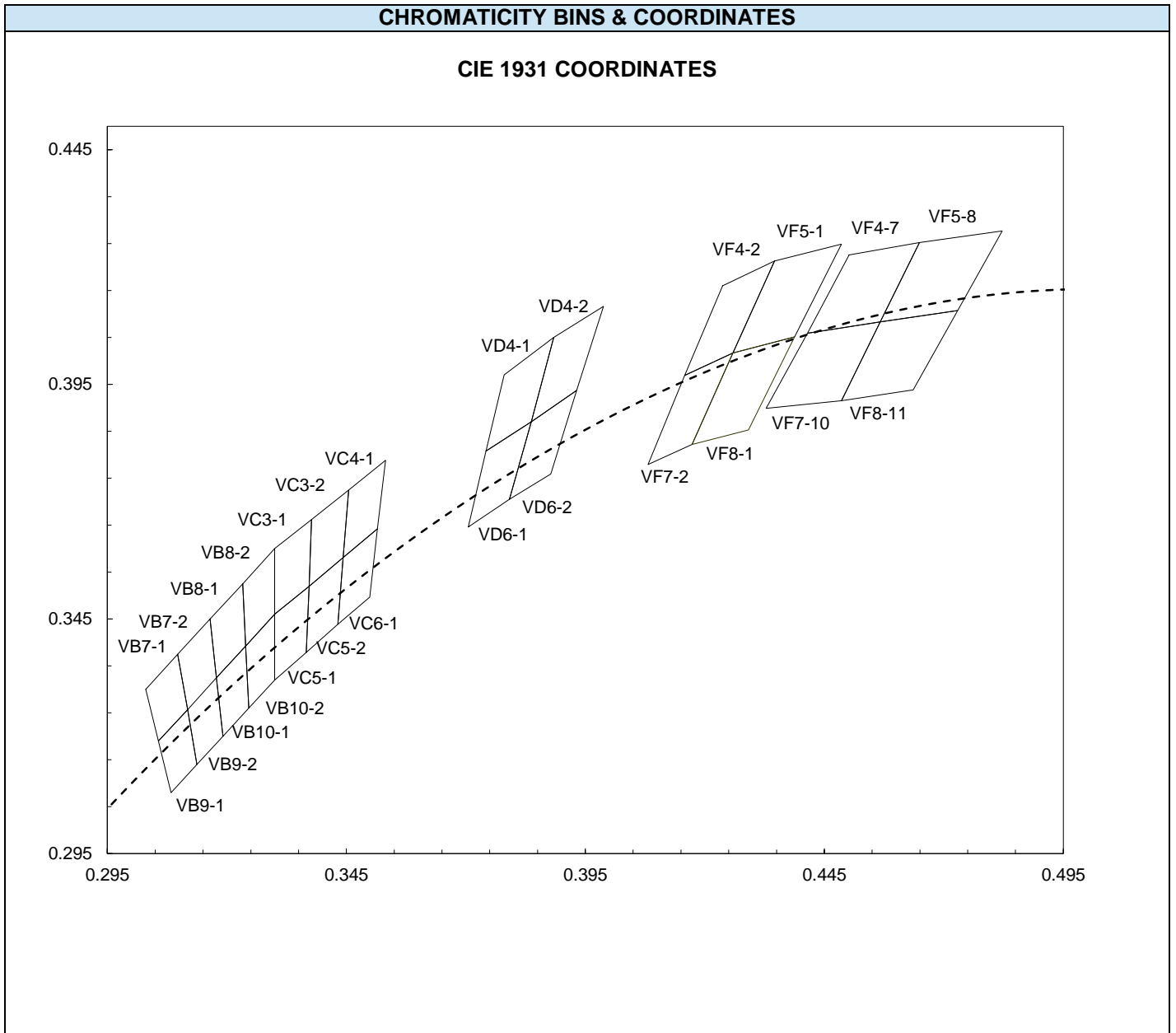

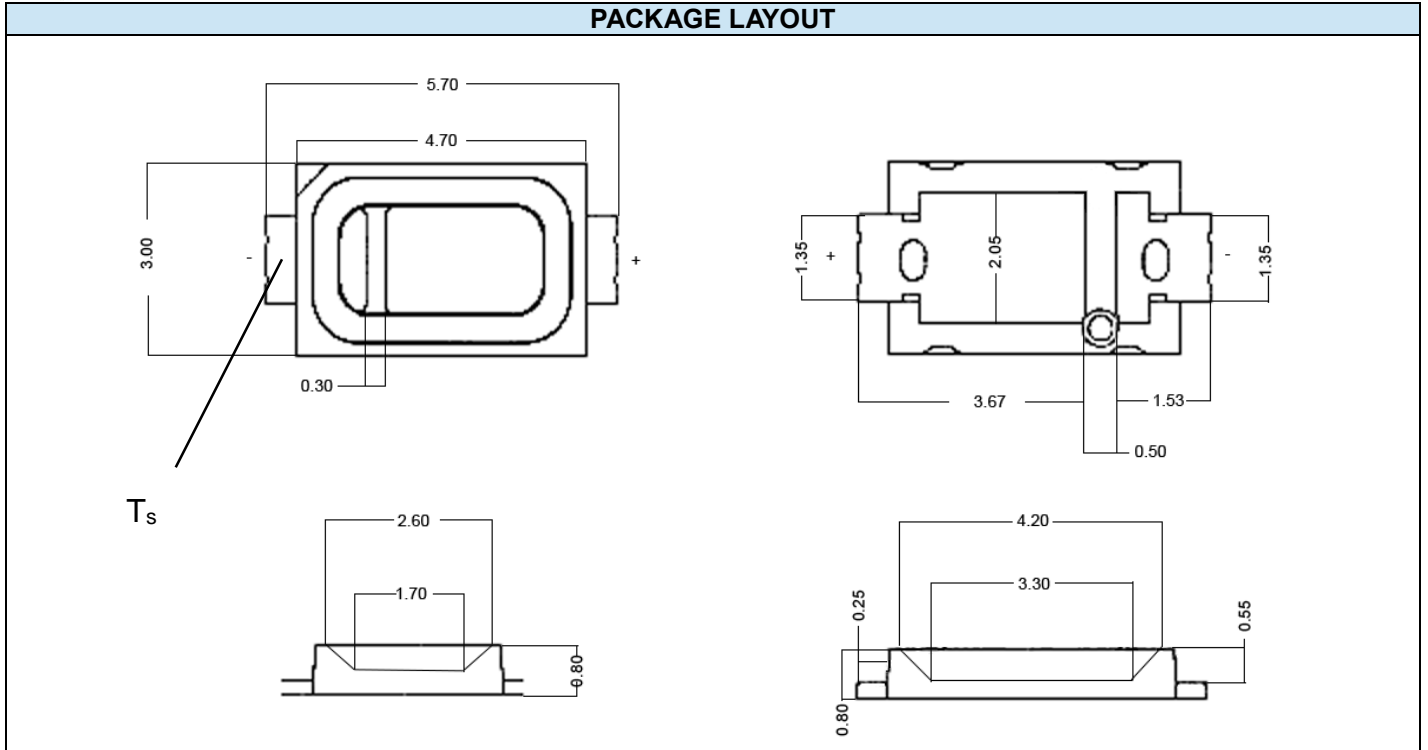

PACKAGE MATERIALS	
ITEM	DESCRIPTION
DIE MATERIAL	InGaN
LEAD FRAME MATERIAL	PPA
ENCAPSULANT RESIN MATERIAL	SILICONE + PHOSPHOR
ELECTRODES MATERIAL	SILVER-PLATED COPPER

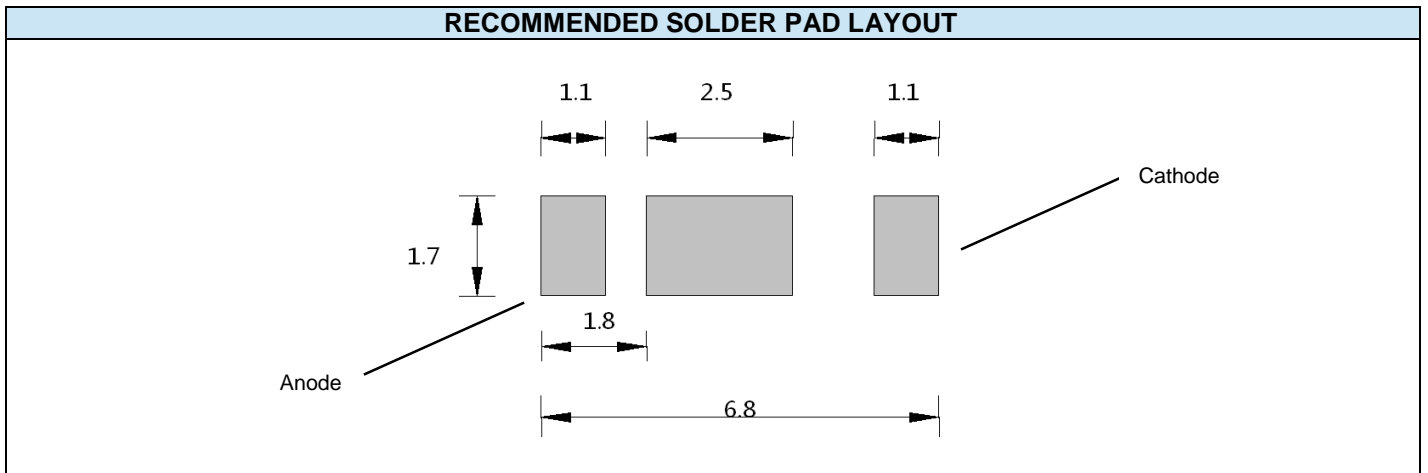

CHARACTERISTIC CURVES

ALL CHARACTERISTIC CURVES ARE FOR REFERENCE ONLY AND NOT GUARANTEED

FORWARD CURRENT
VS FORWARD VOLTAGE ($T_A=25^\circ\text{C}$)

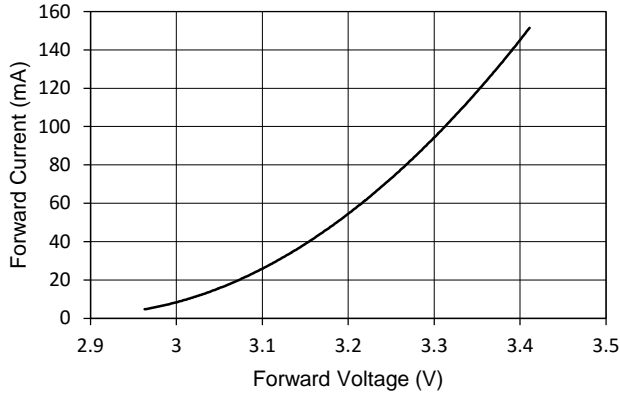

FORWARD CURRENT
VS RELATIVE LUMINOUS OUTPUT ($T_A=25^\circ\text{C}$)

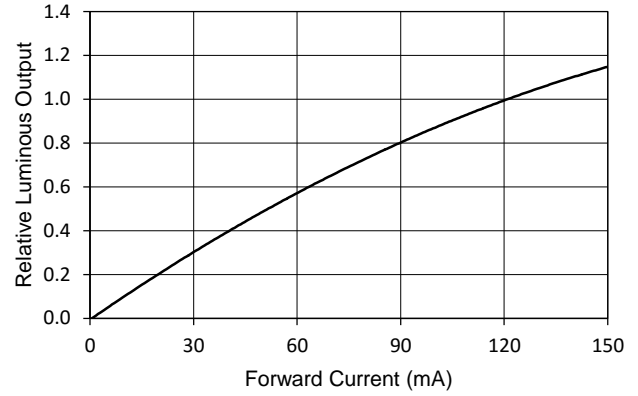

SOLDER POINT TEMPERATURE
VS FORWARD VOLTAGE ($I_F = 120\text{ mA}$)

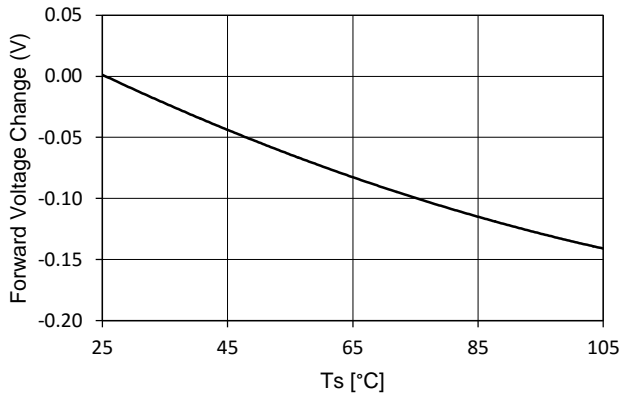

SOLDER POINT TEMPERATURE
VS RELATIVE LUMINOUS OUTPUT ($I_F = 120\text{ mA}$)

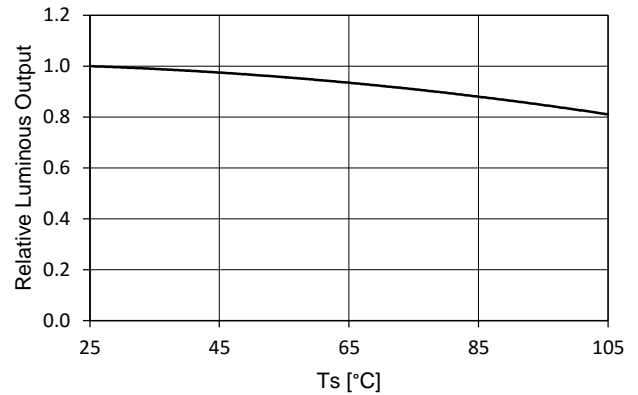

FORWARD CURRENT VS CHROMATICITY SHIFT
(4000K, $T_A=25^\circ\text{C}$)

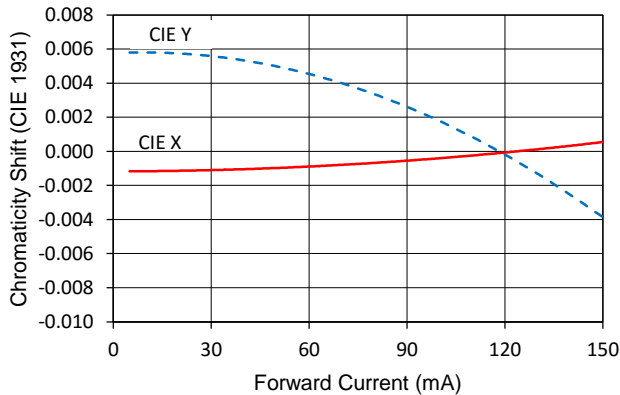

FORWARD CURRENT VS CHROMATICITY SHIFT
(4000K, $T_A=25^\circ\text{C}$)

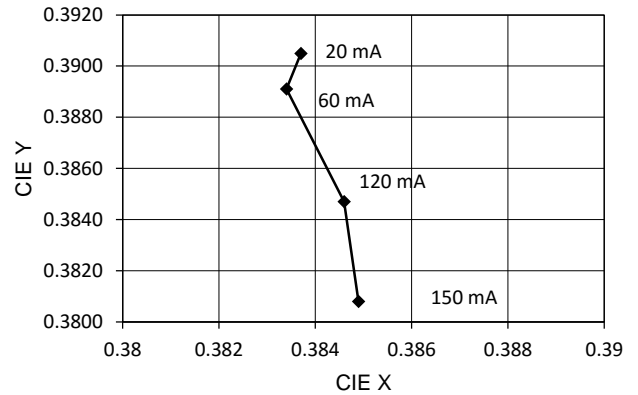

CHARACTERISTIC CURVES (CONTINUED)

SOLDER POINT TEMPERATURE
VS CHROMATICITY (3200K, $I_F = 120$ mA)

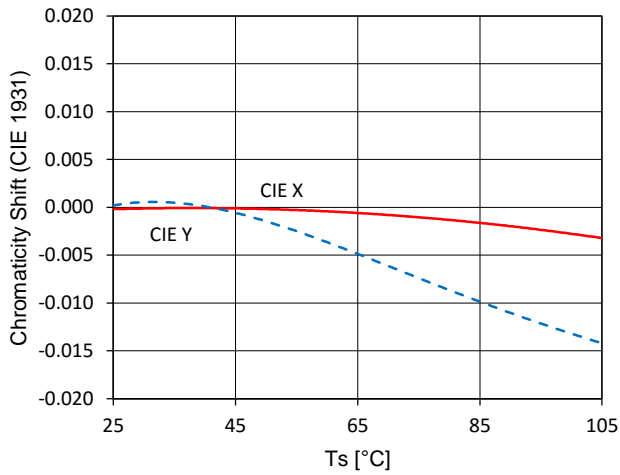

SOLDER POINT TEMPERATURE
VS CHROMATICITY (3200K, $I_F = 120$ mA)

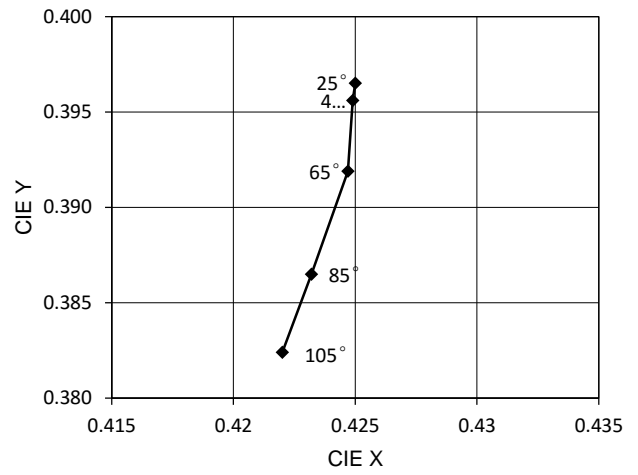

FORWARD CURRENT DERATING BASED ON SOLDER POINT

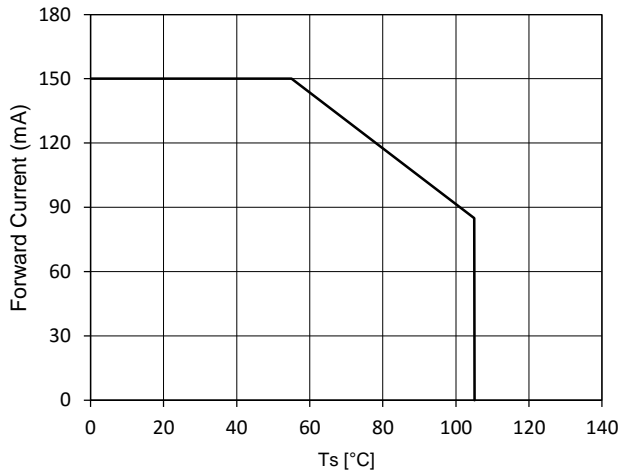

NOTE: DE-RATING CURVES ARE MEANT FOR RECOMMENDATION ONLY AND ARE NOT MEANT TO PROVIDE GUARANTEES OF PRODUCT STABILITY AND LONGEVITY

TYPICAL SPATIAL DISTRIBUTION
($T_A = 25^\circ\text{C}$, $I_F = 120$ mA)

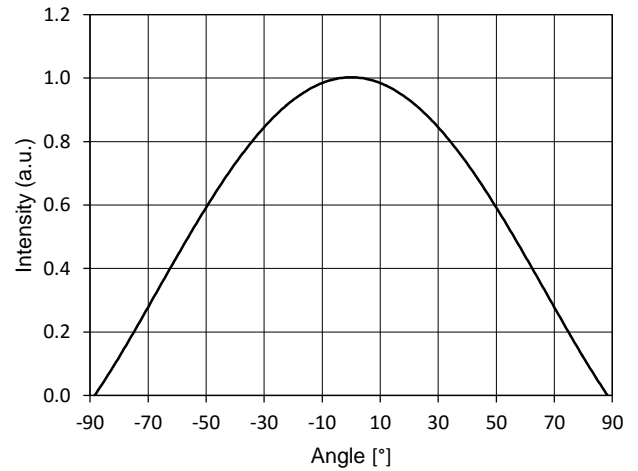

TYPICAL SPECTRAL DISTRIBUTION GRAPHS

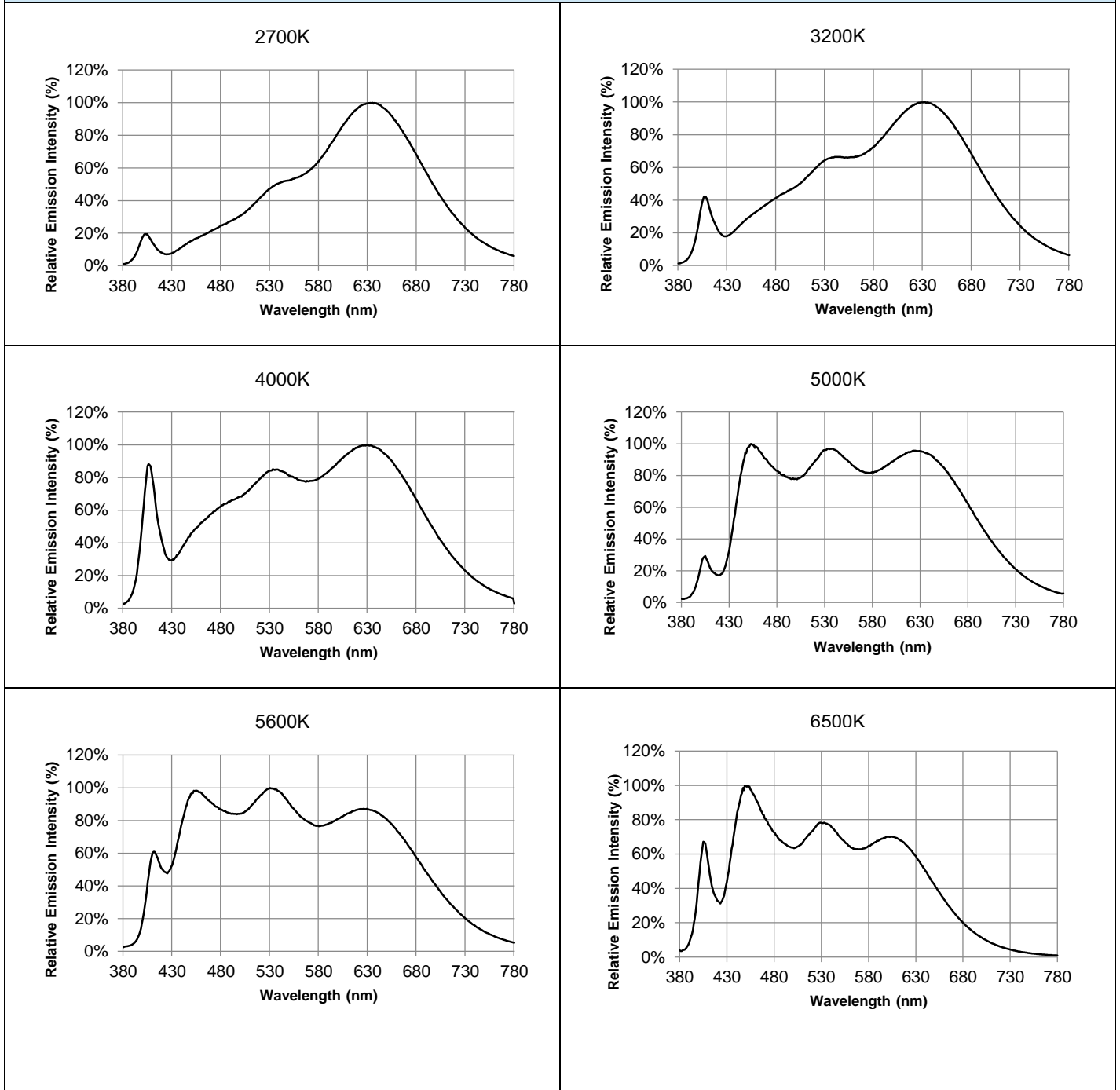

REFLOW PROFILE

SOLDERING RAMP-UP TIME (Pb-FREE)

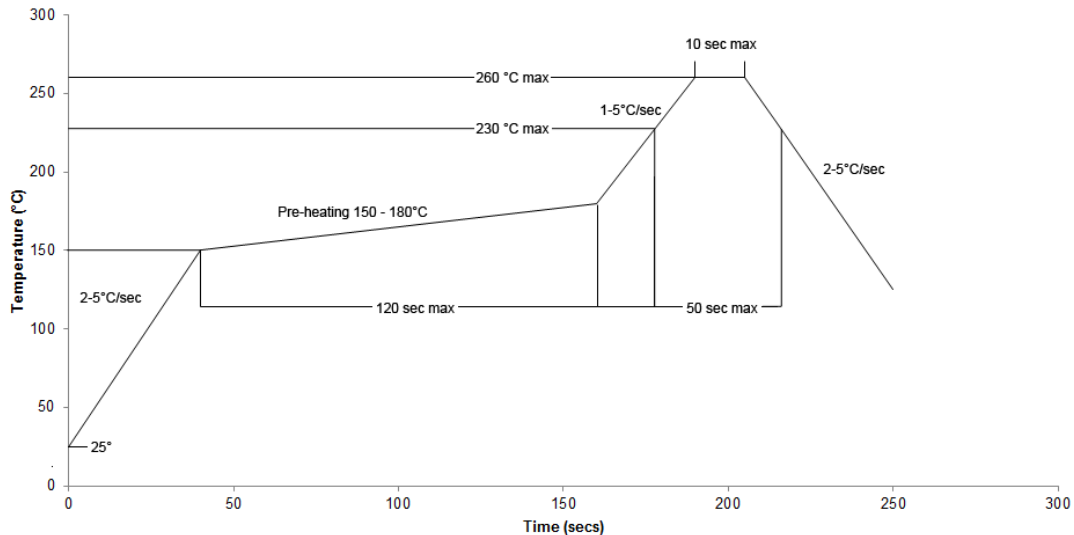

NOTE: Solder paste with the melting point at 230°C is recommended

INSTRUCTIONS FOR SMT

Problems caused by improper selection of collet

Choosing the right collet is important in ensuring product quality after SMT. LEDs are different from other electronic components, as they are not only concerned with electrical output but also optical output. This characteristic makes LEDs more fragile in the process of SMT. If the collet's lowering height is not well set, it will bring damage to the gold wire at the time of collet's pick-and-place process which can cause the LED to not illuminate, flicker or contribute to other quality problems, some of which may not be immediately detectable.

Collet selection

During SMT, please choose the collet that has larger outer diameter than the lighting area of lens, in order to avoid damage the gold wire inside the LED. Different collets fit for different products, please refer to the following figures below.



Setting the height of the collet is crucial in order to avoid damage to the top view SMD. If the collet setting is set to too low of an altitude, the collet will press down on the SMD, causing damage or breakage to the encapsulant and cause distortion or breakage of the gold wire.

Other notes of caution:

- No pressure should be exerted to the epoxy shell of the SMD under high temperature.
- Do not scratch or wipe the lens since the lens and gold wire inside are rather fragile and cross out easy to break.
- LED should be used as soon as possible when being taken out of the original package, and should be stored in anti-moisture and anti-ESD package.
- This usage and handling instructions are for reference only.

TAPE SPECIFICATIONS

TAPE DIMENSIONS (UNIT: MM)

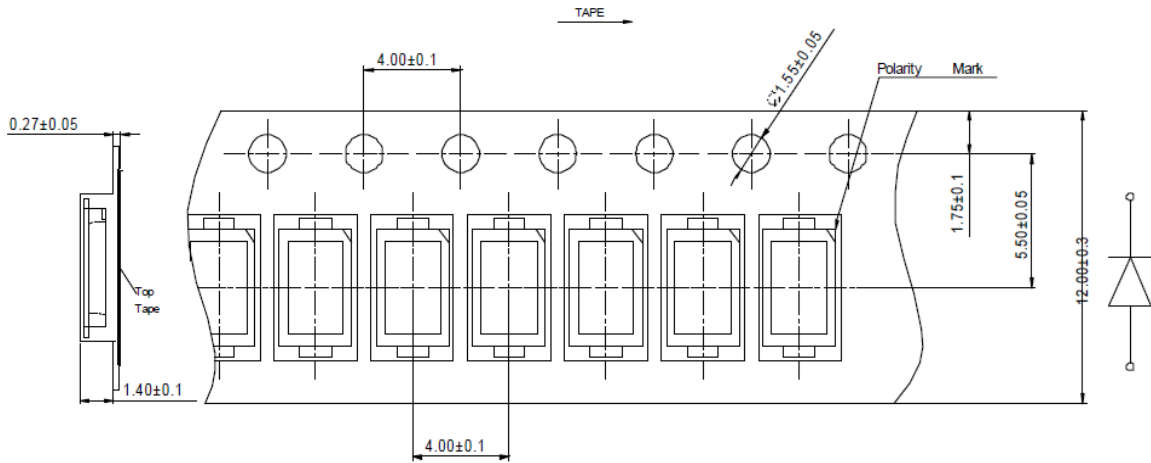

TAPE LAYOUT (NOT DRAWN TO SCALE)

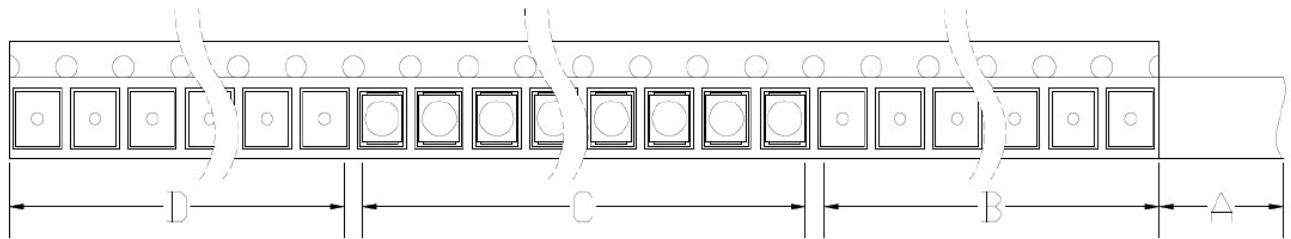

- A: COVER TAPE, 300 MM;
- B: EMPTY LEADER, 200 MM;
- C: LED, 3000 PCS;
- D: EMPTY TRAILER, 200 MM;

REEL SPECIFICATIONS

REEL DIMENSIONS TOP (UNIT: MM)

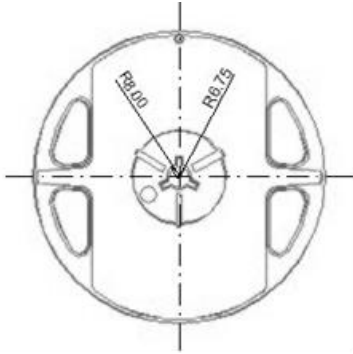

REEL DIMENSIONS BOTTOM (UNIT: MM)

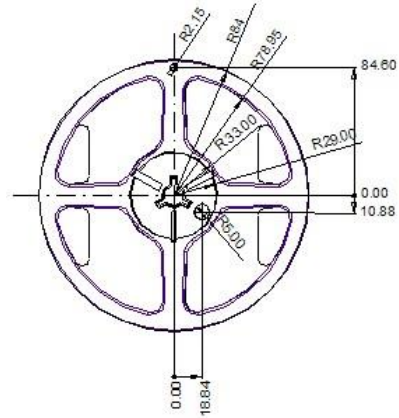

REEL DIMENSIONS SIDE (UNIT: MM)



FEEDING DIRECTION

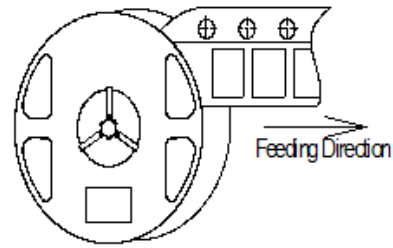

LOT NUMBERING SCHEME

Yuji LED uses two formats for lot numbering purposes:

1) YYYY-MM-XXX-Z

YYYY: 4-digit manufacturing year
MM: 2-digit manufacturing month
XXX: 3-digit inventory number (000 – 999)
Z: internal alphanumeric code

2) YYYYMMXXX

YYYY: 4-digit manufacturing year
MM: 2-digit manufacturing month
XXX: 3-digit inventory number (000 – 999)

SHIPPING INFORMATION

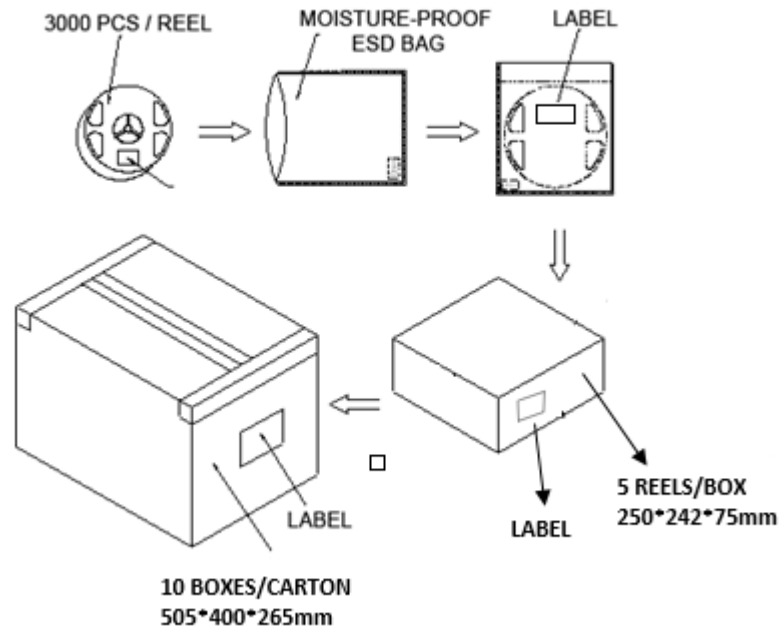

NOTES:

1. Reeled products (max 3,000 pcs / reel) are packed in a moisture-proof bag along with a moisture desiccant pack.
2. Each inner box contains up to 5 moisture-proof bag of (total maximum number of SMDs is 15,000pcs). Box package size: 250 mm x 242 mm x 75 mm.
3. Each outer package contains 10 inner boxes. Box size: 505 mm x 400 mm x 265 mm.
4. Outer package is sealed with protective bubble wrap and foam. (Part numbers, lot numbers, quantity should appear on the label on the moisture-proof bag, part numbers).
5. This packaging merely intended as a reference for standard quantity orders only – please note that actual packaging can differ depending on the order circumstances.