

- - - MOUNTAIN BIKE PRODUCTS ORDER FORM - - -

Customer Name:

Billing Address:

Shipping Address:

Fiscal Code / VAT Number:

Phone Number:

Email: @

ONLY FOR ITALIAN COMPANY
 PEC: @
 SDI:

Payment Method: in advance only with PayPal / Credit Card

PLEASE NOTE: production will start once the Administration Dept. have received money accreditation.

- - - TECH DATAS - - -

SHOCK SIZE: (length / stroke) SHOCK TYPE: ARMA V3 - STORIA V3

SHOCK LAYOUT: Eye To Eye - Trunnion

Bike Brand, Model and Year:

Bike size: Rider Weight: Kg Rear travel:

Wheels: 26" - 27,5" - 29" Pedals: FLAT - CLIP

Used a coil shock before? What kind of spring rate do you used?: lbs/in

SC Upper **DU** Bushing Yes please - No thanks
 EY Lower **DU** Bushing Yes please - No thanks

Hardware Kit: Yes please - No thanks
 Upper Hardware length mm
 Lower Hardware length mm
 Screw Diameter mm
 Screw Diameter mm

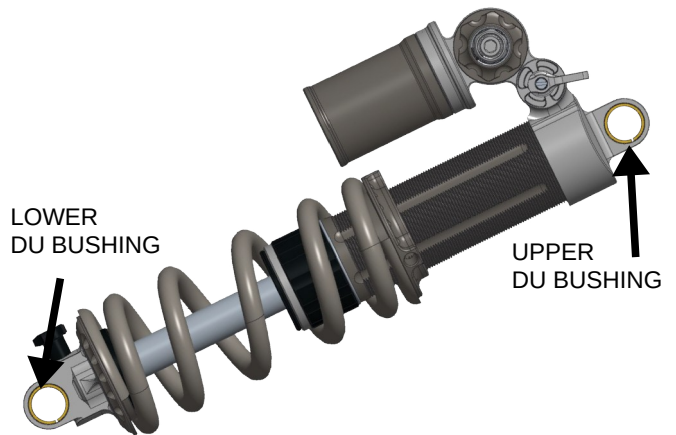
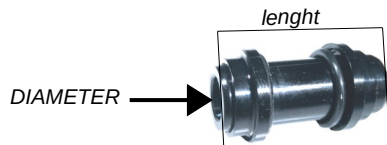

NOTE:

Once filled, please send back to commerciale@extremeshox.com

