



2023-US

Catalog for outdoor Light



 www.aaledlighting.com/

Contents

Outdoor Light



01-PKC



02-FLC



03-FLC



04-SKY



05-HPC



06-HPE



07-WPA



08-WPB



09-WPB3



10-WPC2



11-WPD



12-PGC



13-PGB



14-PGA



15-CNB



16-GSA

LED Parking Lot / LED Area Light



01

PKC

75W-300W



02

FLC

150W-200W



03

FLC

15W-100W



04

SKY

30W-600W

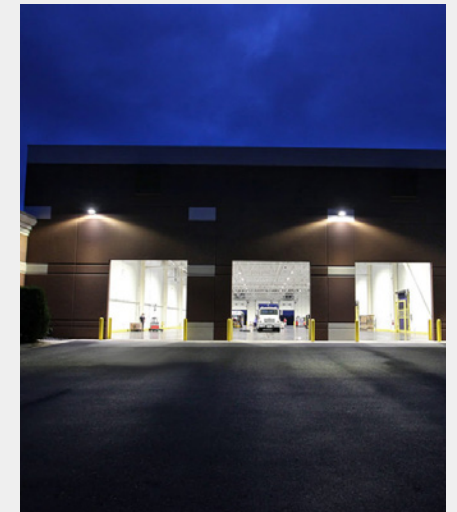

PKC

LED Parking Lot Light

- DLC 5.1 Premium Listed
- 3-Power & 3-CCT switchable
- IP66 Wet Location
- High efficacy up to 180LM/W
- SCP/OVP/OTP protection driver
- 6KV/10KV surge protection
- Multi-Voltage 100-277/347V, 277-480V
- 0-10V Dim, Photocell, Sensor, Bluetooth Mesh optional



01/

Bracket Optional



Slip Fitter

Arm/Wall Mount

Trunnion

"U" Yoke Bracket

3-Power & 3-CCT Switchable

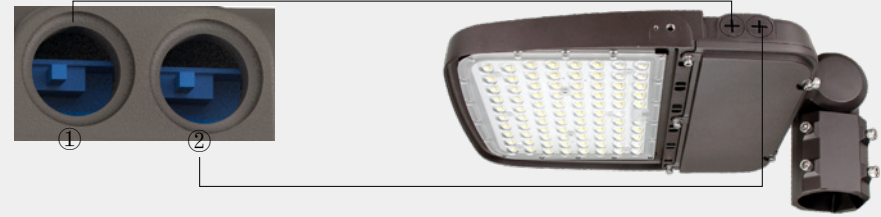

① Remove Cover For 3 Power Switchable

② Remove cover for 3-CCT Switchable

Distribution Optional

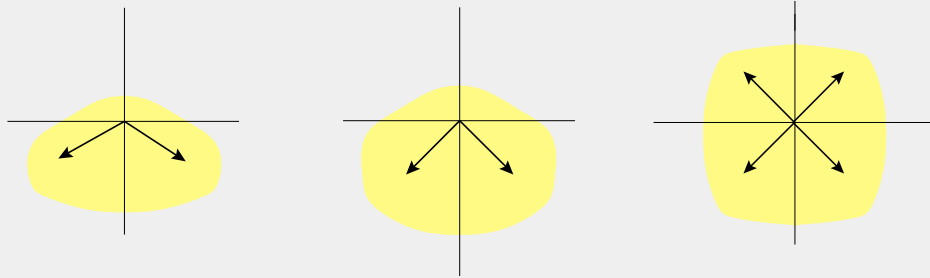

TYPE 3

TYPE 4

TYPE 5

Function Optional



Small Photocell
(at side)



Photocell
(NEMA Socket at Back)

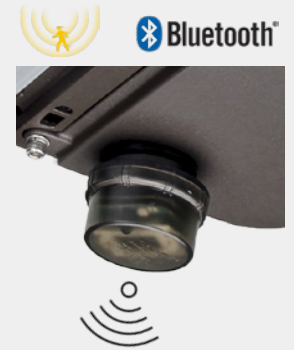

Sensor+Photocell
(ZHAGA Socket at front)

Parameter

Model No.	Power	Input	Efficacy	Lumens	Ra	CCT	Control
PKC-150W/100W/75W	150W/100W/75W	100-347V/277-480V	160LM/W	24000LM	>70		
PKC-240W/200W/150W	240W/200W/150W	100-347V/277-480V	160LM/W	38400LM	>70	3000K 4000K 5000K	0-10V Dim Photocell Motion Sensor Bluetooth Zigbee
PKC-300W/240W/200W	300W/240W/200W	100-347V/277-480V	160LM/W	48000LM	>70		
PKC-200W/150W/100W	200W/150W/100W	100-347V/277-480V	160LM/W	32000LM	>70		
PKC-240W/200W/150W	240W/200W/150W	100-347V/277-480V	160LM/W	38400LM	>70	3-CCT Switchable	

Smart Function optional



Plus & Play different cover for different function



PHOTOCELL



Photocell

Operation Level

ON	10-20LUX
OFF	30-80LUX



Sensor
(PIR or Microwave)



Remote control



Bluetooth
Bluetooth Mesh Sensor
(PIR or Microwave)



APP/Wall Switch/Remote Control

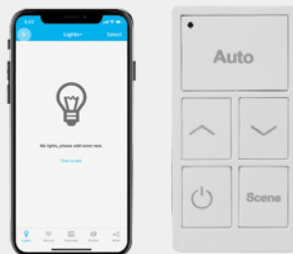

Bluetooth SIG Mesh Sensor and dimming Control

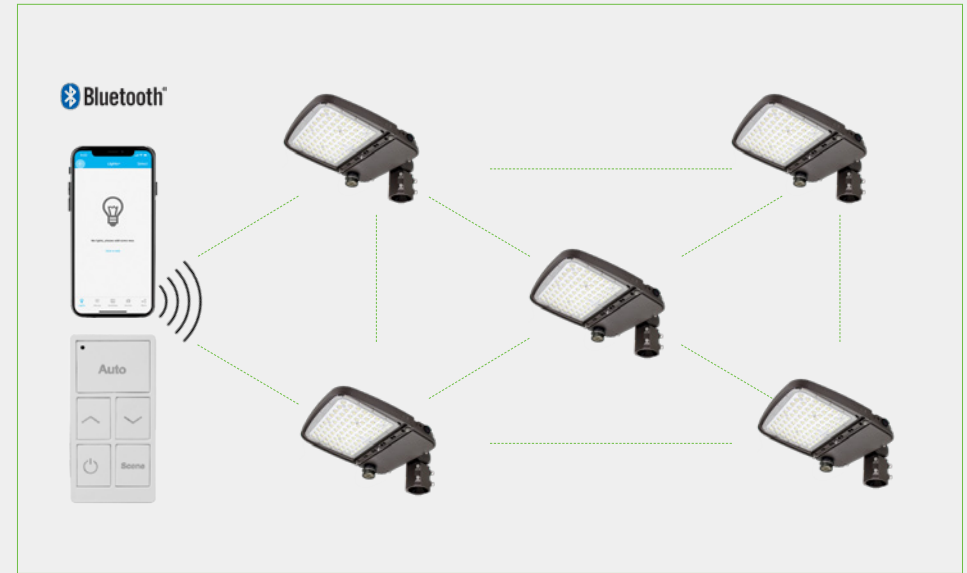

Wireless Bluetooth SIG Mesh between 30M/100FT
Distance of two Fixtures.



Group control, Support 100pcs in one Group.



Schedule and Timer, like 9:00AM ON, 18:00 OFF.



Scene Setting, like meeting, working etc.



Motion Sensor and Daylight harvest options,
automatically turn on, turn off and dim the lights.



Linkage, other lights in the same group detects movement, and the linkage is turned on in this group, then this light will dim to linkage light level.



Wireless Control and no need Hub



APP System is Easy to operated

FLC

02/

200W-150W-100W Switchable Area Light

- DLC 5.1 Premium Listed
- Integrated visor for reduced glare
- IP65 against dust and water
- Slip Fitter bracket mount or “U” YOKE bracket mount
- High Lumens 140LM/w
- Photocell optional



Bracket optional



Slip Fitter



Trunnion



YOKE Bracket

Advantage

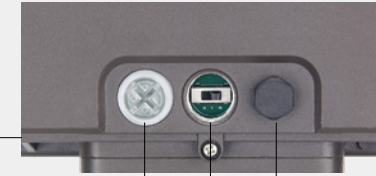

Photocell 3-Power Switchable Respirator

Distribution

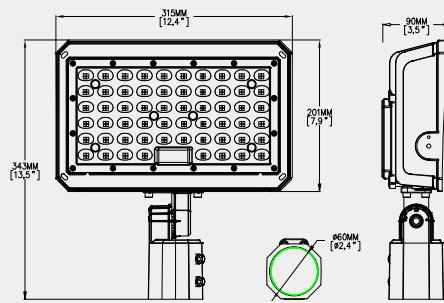
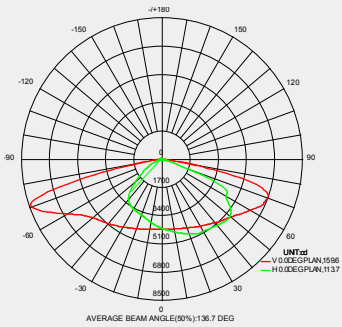

Have an integrated visor that reduces observable glare.



Suitable for ground mounting Specialized Drainage Notch For Drain away water. Don't worry the water will go into the lamp body!



High efficiency fresnel lens, up to 140m/w, Glare-Free to protect people eyes!

Parameter

Model No.	Power	Input	Efficacy	Lumens	Ra	Beam Angle	CCT	Control
FLC-150W	150W-100W-80W	100-277V/347V	140LM/W	21000LM	>70	T3	3000K 4000K 5000K	0-10V Dim Photocell
FLC-200W	200W-150W-100W	100-277V/347V	140LM/W	28000LM	>70			

FLC

15W-100W LED Flood Light

- DLC 5.1 Premium Listed
- 15W 30W 50W 80W 100W
- IP65 against dust and water
- Slip Fitter bracket mount or
“U” YOKE bracket mount
- High Lumens 140LM/w
- Photocell optional



Bracket optional



The 1/2 NTP
knuckle Bracket



Trunion



"U" Yoke Bracket

Advantage



High efficiency fresnel lens. up to 140m/w. Glare-Free to protect people eyes!



The 1/2 NPSM knuckle mount is designed with rugged, locking Teeth to keep installations securely in place. No drooping!



The "U" YOKE bracket mount Can for more different Installations in different place.

Distribution

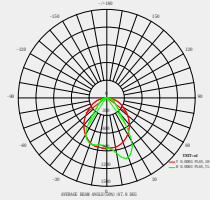

FLC-15W

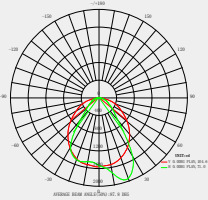

FLC-26W

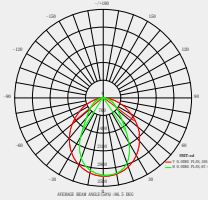

FLC-50W

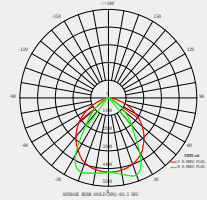

FLC-80W



Have an integrated visor that reduces observable glare.



Suitable for ground mounting Specialized Drainage Notch For Drain away water. Don't worry the water will go into the lamp body!



Photocell option add \$1 only And support to remove it easily
Photocell:
Connect the terminal
Non-photocell:
Remove the terminal

Parameter

Model No.	Power	Dimension	Input	Efficacy	Lumens	Ra	Beam Angle	CCT	Control
FLC-15W	15W	125X123X55mm	100-277V/347V	135LM/W	2000LM	>70			
FLC-26W	26W	125X123X55mm	100-277V/347V	135LM/W	3500LM	>70			
FLC-50W	50W	184X184X60mm	100-277V/347V	135LM/W	6500LM	>70	100°	3000K 4000K 5000K	Photocell
FLC-80W	80W	221X221X71mm	100-277V/347V	135LM/W	11000LM	>70			
FLC-100W	100W	221X221X71mm	100-277V/347V	135LM/W	14000LM	>70			

SKY Series

04/

LED Area Light

- Die-cast aluminum housing has integral fin type heat sink to optimize thermal management.
- Tempered Glass Cover Daylight-Resistant
- Luminous efficacy up to 140LM/W
- L70>100,000-Hours lifespan
- Power supply with 6KV integral surge protection



Power optional

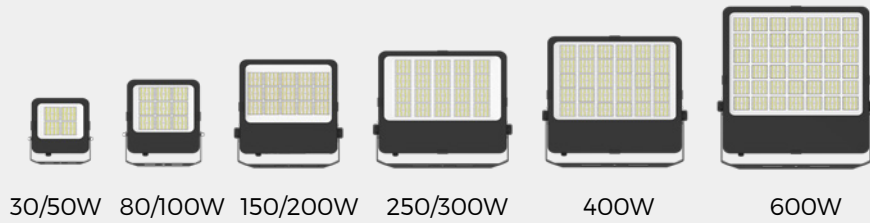

Advantage



Distribution

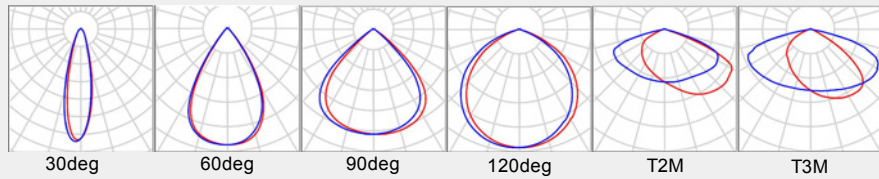

Built-in different lens with different distribution

Angled mounting Bracket for Quick Fix

Parameter

Model No.	Power	Input	Efficacy	Lumens	Ra	Beam Angle	CCT	Control
PKB-30W	30W	100-277V/347V	140LM/W	4200LM	>80			
PKB-50W	50W	100-277V/347V	140LM/W	7000LM	>80			
PKB-75W	75W	100-277V/347V	140LM/W	10500LM	>80			
PKB-100W	100W	100-277V/347V	140LM/W	14000LM	>80			
PKB-150W	150W	100-277V/347V	140LM/W	21000LM	>80	30° 60° 90°	Single Color or 3-CCT Switchable	0-10V Photocell
PKB-200W	200W	100-277V/347V	140LM/W	28000LM	>80	120°		
PKB-300W	300W	100-277V/347V	140LM/W	42000LM	>80	t2		
PKB-400W	400W	100-277V/347V	140LM/W	56000LM	>80	t3		
PKB-500W	500W	100-277V/347V	140LM/W	70000LM	>80			
PKB-600W	600W	100-277V/347V	140LM/W	84000LM	>80			

High Pole Light / Stadium Light

05
HPC



06
HPE

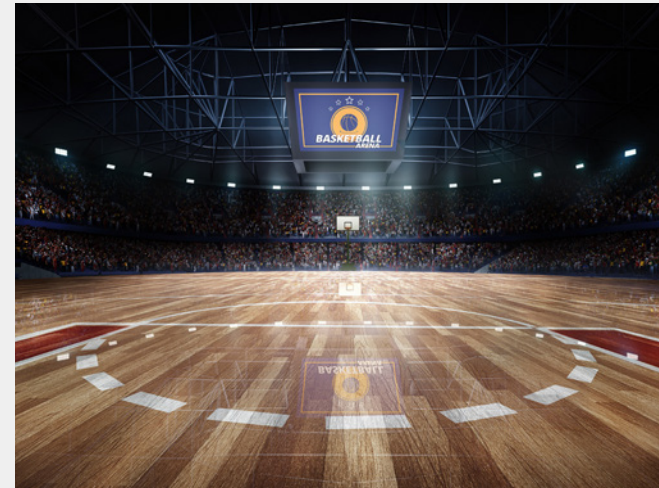
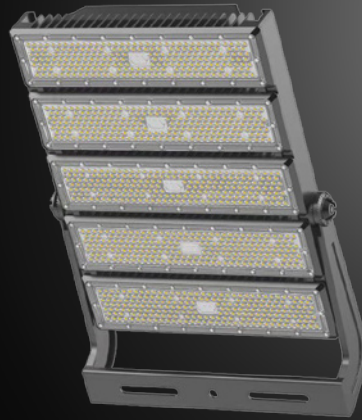

HPC

High Pole Stadium Light

- High Quality Driver, Surge protection:10KV.
- High Luminous Efficacy up to 150lm/w
- Cast aluminum design, better cooling and easy replacement.
- IP67 IK10
- Adjustable beam angle up to 180°
Simple bolt on mounting template.



Distribution

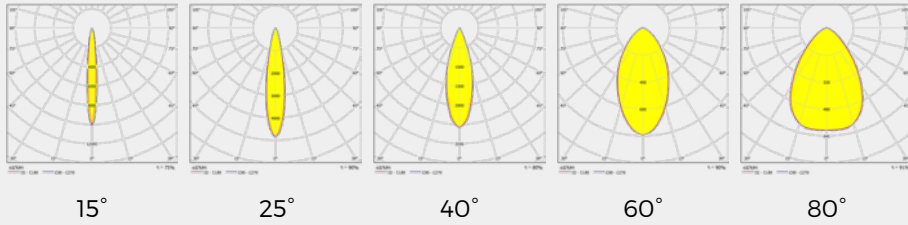

Dimension

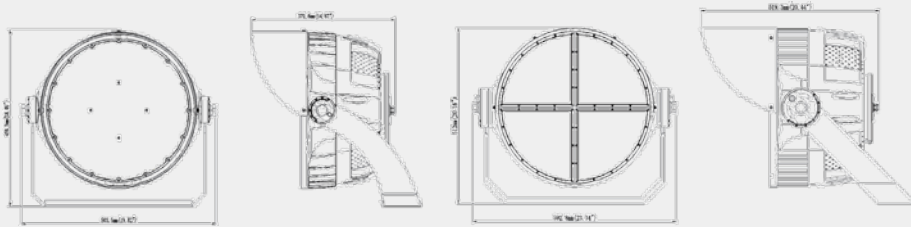

Parameter

Model No.	Power	Input	LEDs	Efficacy	Lumens	Ra	Beam Angle	CCT	Control
HPC- 500W-XX-H-XXK	500W	100-277V/277-480V	5050	150LM/W	75000LM	>80			
HPC- 600W-XX-H-XXK	600W	100-277V/277-480V	5050	150LM/W	90000LM	>80	15°	3000K	0-10V Photocell
HPC- 800W-XX-H-XXK	800W	100-277V/277-480V	5050	150LM/W	120000LM	>80	25°	4000K	
HPC- 1000W-XX-H-XXK	1000W	100-277V/277-480V	5050	150LM/W	150000LM	>80	40°	5000K	
							60°	5700K	
							80°	6500K	
HPC- 1200W-XX-H-XXK	1200W	100-277V/277-480V	5050	150LM/W	180000LM	>80			

Advantage

Laser Aiming Device

(It can benefit for controlling the lighting beam angle accurately and locate the best installation place for each fixture.)

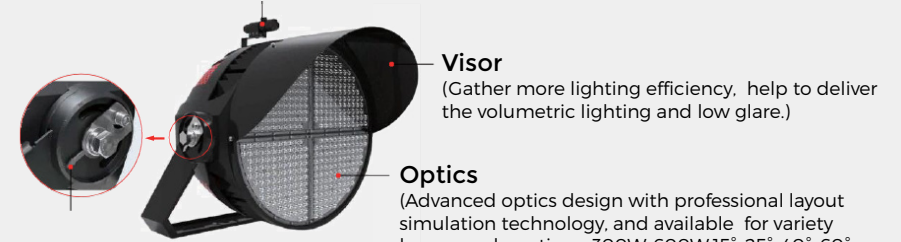

Visor

(Gather more lighting efficiency, help to deliver the volumetric lighting and low glare.)

Optics

(Advanced optics design with professional layout simulation technology, and available for variety beam angle options: 300W-600W:15°, 25°, 40°, 60°; 800W-1200W:15°, 40°, 60°, 80°)

Pointer Board

(When Spot Light adjust to specified angle, pointer board will show the exact scale on bracket with detail angle.)

Cooling system

(Apart from the fixture with individual heat sink design, greatly help to deliver the heating dissipation. L70 from ISTMT >60,000Hours.)

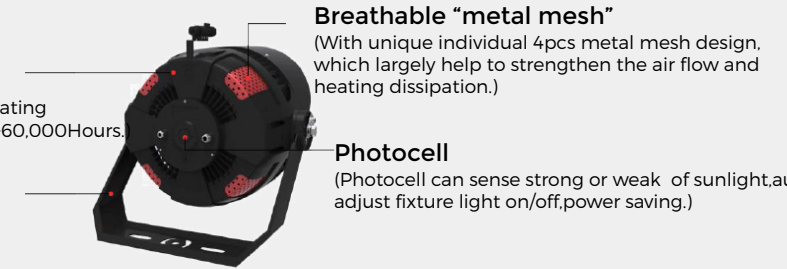

Breathable "metal mesh"

(With unique individual 4pcs metal mesh design, which largely help to strengthen the air flow and heating dissipation.)

Photocell

(Photocell can sense strong or weak of sunlight, auto adjust fixture light on/off, power saving.)

Bracket

(Fix whole fixture and installation, Up and down adjustable Angle: 0- 180°)

Waterproof (IP67)

(Dustproof, waterproof, breathable, can balance air pressure between inside and outside of fixture.)

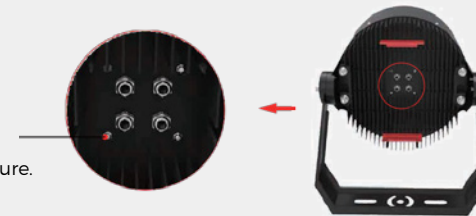

HPE

06/

High Pole Stadium Light

- High Quality Driver, Surge protection: 10KV
- High Luminous Efficacy up to 140lm/w
- IP66 IK10
- Simple bolt on mounting template.
- Cast aluminum design, better cooling and easy replacement.
- Excellent optical design, greatly improve the light utilization and evenness.

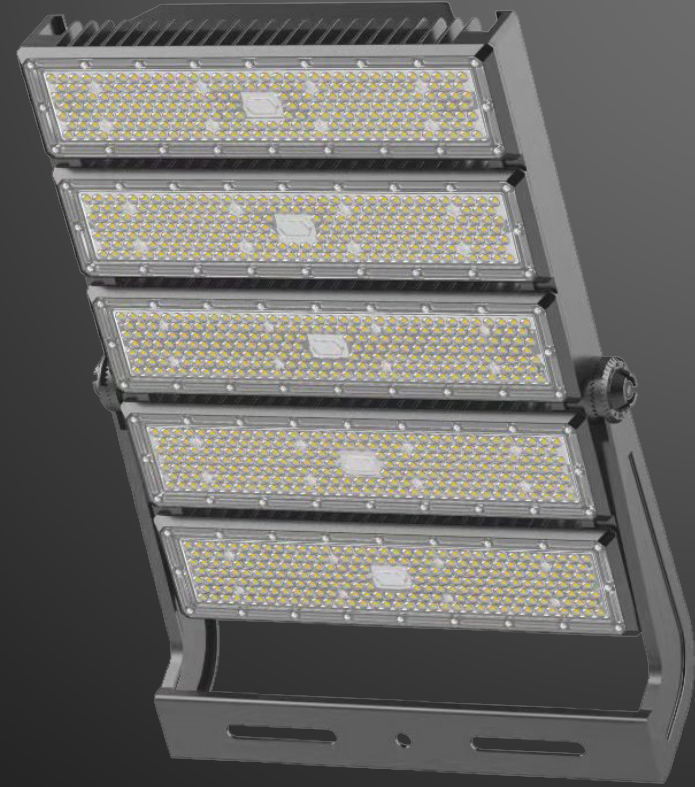

Distribution

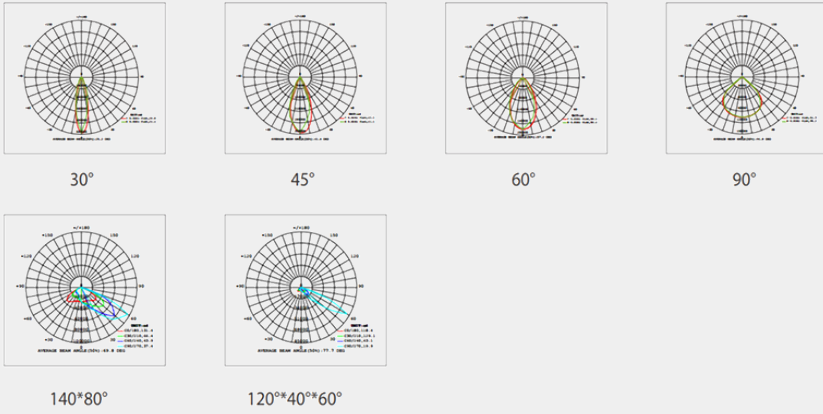

Installation

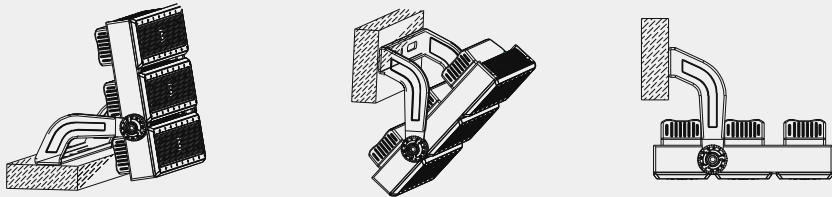

Parameter

Model No.	Power	Input	LEDs	Efficacy	Lumens	Ra	Beam Angle	CCT	Control
HPE-600W-XX-H-XXK	600W	100-277V	3030	140LM/W	84000LM	>70			
HPE-800W-XX-H-XXK	800W	100-277V	3030	140LM/W	112000LM	>70	30°		
HPE-1000W-XX-H-XXK	1000W	100-277V	3030	140LM/W	140000LM	>70	45°	4000K	
HPE-1200W-XX-H-XXK	1200W	100-277V	3030	140LM/W	168000LM	>70	60°	5000K	
HPE-1400W-XX-H-XXK	1400W	100-277V	3030	140LM/W	196000LM	>70	90°	5700K	0-10V Dim
HPE-1600W-XX-H-XXK	1600W	100-277V	3030	140LM/W	224000LM	>70	80°x140° 120°x40°x60°	6500K	

Advantage

Die Casting Heat Sink: Excellent Thermal Management & Compact Structure

Single Module 200W, Up To 8 Modules Can Be Combined Into 1600W

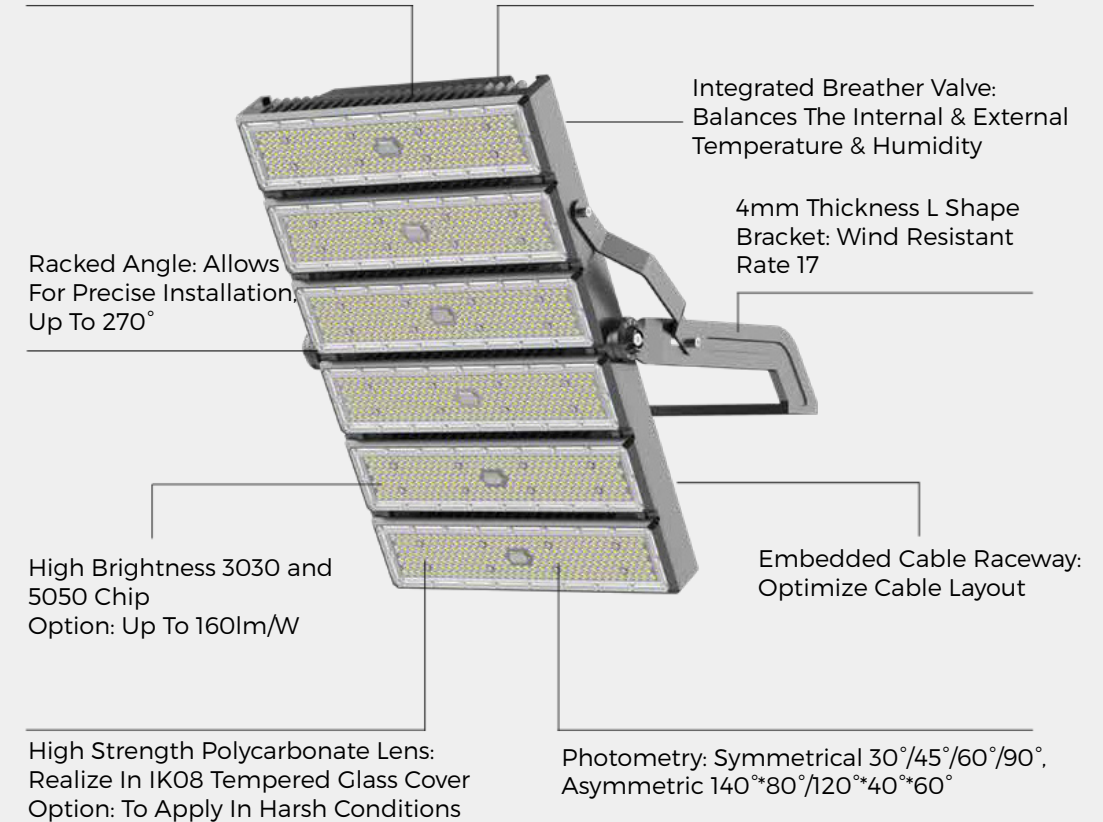

LED Wall Pack Light



07

WPA



08

WPB



09

WPB3



10

WPC2



11

WPD2

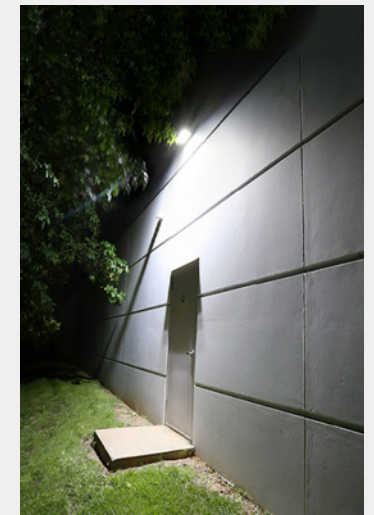
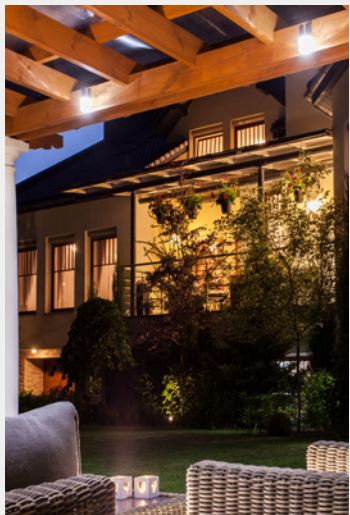

WPA

07/

Mini LED Wall Mount



18W



26W



20W/25W



30W-35W



18W Dimension



26W Dimension

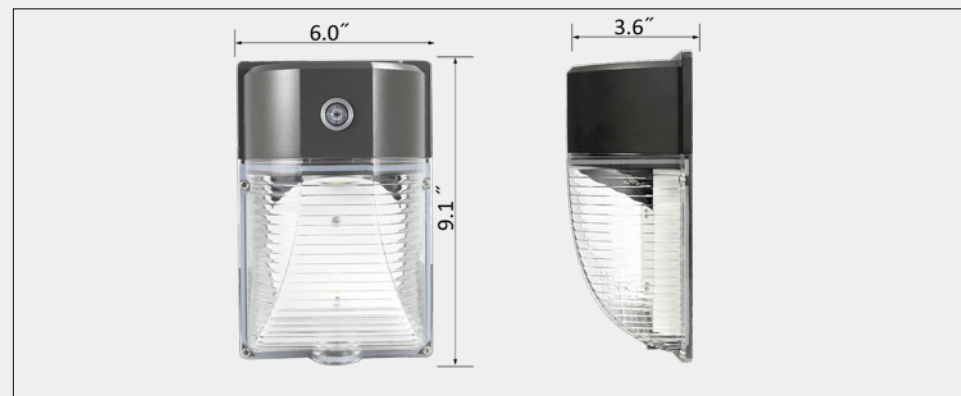

20W/25W Dimension

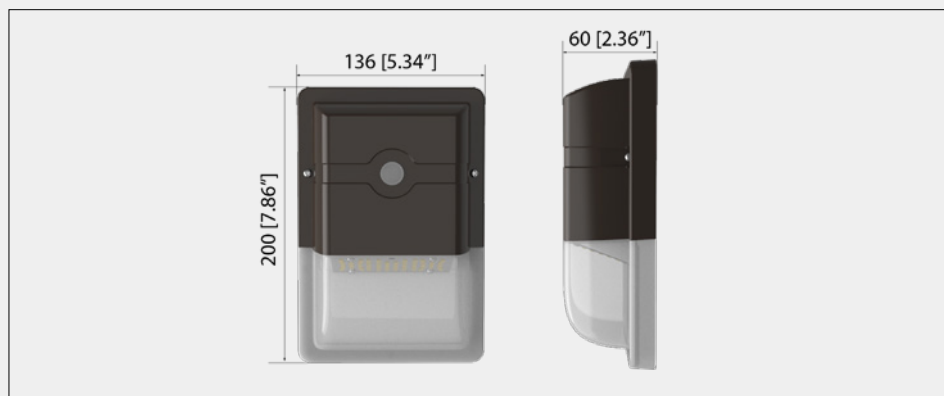

30W-35W Dimension

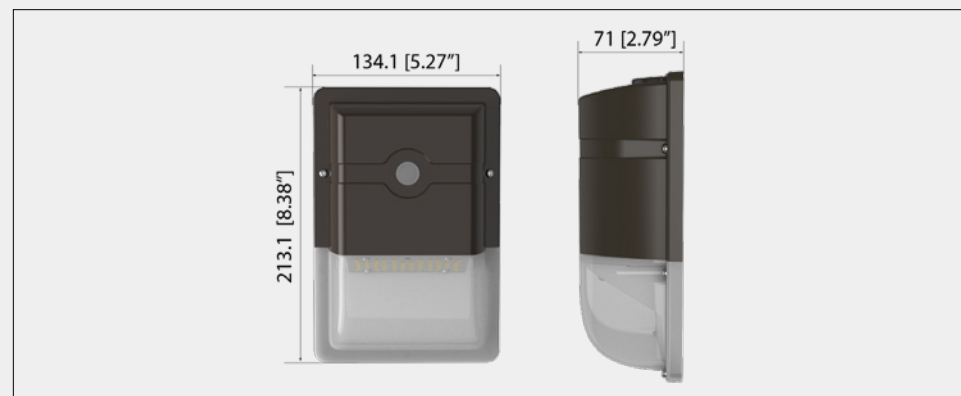

Parameter

Model No.	Power	Input	Efficacy	Lumens	Ra	Beam Angle	CCT	Control
WP-18A2	18W	100-277V/347V	120LM/W	2100LM	>70	120°	3000K 4000K 5000K	Photocell
WP-26A2	26W	100-277V/347V	120LM/W	3000LM	>70			
WP-20/25A3	20/25W	100-277V/347V	120LM/W	2400/3000LM	>70			
WP-30/35WA3	30/35W	100-277V/347V	120LM/W	3600/4200LM	>70			

WPB

08/

Traditional Half Cut-off Wall Pack

- DLC 5.1 Premium Listed
- High Lumens 130lm/w
- 3-Power & 3-CCT Switchable
- IP65 Wet Location
- Wall Mounted
- Photocell Removable



Distribution

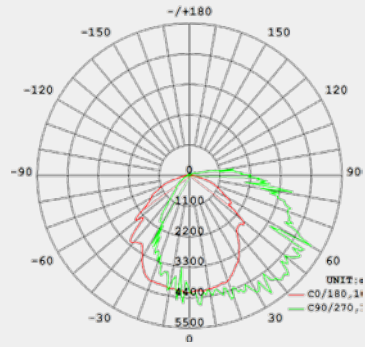

Dimension

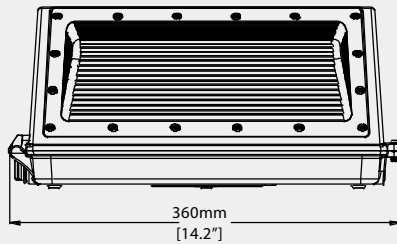
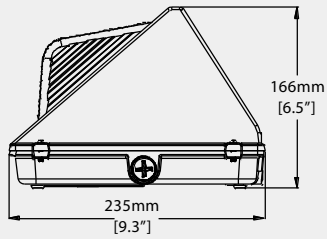

Advantage



Zonal lumen 0-90°>97%



Photocell Dusk to Dawn
(providing shorting cover)



3-CCT Switchable
3-Power Switchable

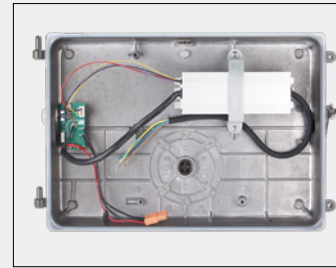

High Quality Driver
Multi Voltage 100-277V/347V



Saving Shipping cost Design
Extremely compact and safety package design
40HQ Container can load around 3400pcs

Parameter

Model No.	Power	Input	Efficacy	Lumens	Ra	Beam Angle	CCT	Control
WP-42B	42W	100-277V/347V	130LM/W	5200LM	>70	120°	Single color 3-CCT Selectable	Photocell 0-10V Sensor Emergency
WP-60B	60W/50W/40W Selectable	100-277V/347V	130LM/W	7800LM	>70			
WP-80B	80W	100-277V/347V	130LM/W	10400LM	>70			
WP-100B	100W	100-277V/347V	130LM/W	13000LM	>70			
WP-120B	120W/100W/60W Selectable	100-277V/347V	130LM/W	15600LM	>70			
WP-150B	150W	100-277V/347V	130LM/W	19500LM	>70			

WPB3

09/

Professional Half Cut-off Wall Pack

- 3-Power and 3-CCT Switchable, easy to make inventory reserve.
- 1-10V Dimmable optional
- Photocell optional
- IP65 Wet Location
- High Luminous Efficacy up to 130lm/w
- Multi-Voltage: 100-277Vac or 100-347Vac



Glass Cover



Distribution

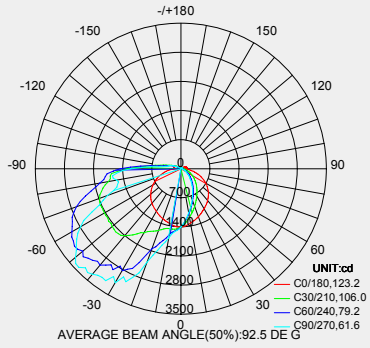

Advantage



ON/OFF Photocell 3-CCT Switchable 3-Power Switchable

Dimension

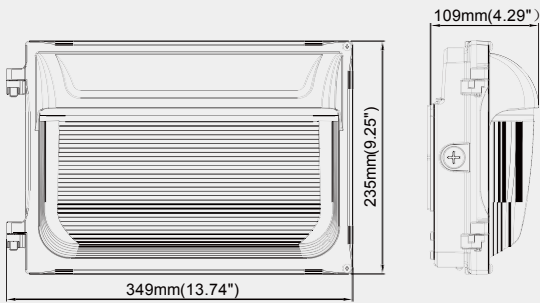

Parameter

Model No.	Power	Input	Efficacy	Lumens	Ra	Beam Angle	CCT	Control
WPB3-60W	60W-40W-30W	100-277V/347V	135LM/W	8100LM	>80	120°	Single color 3-CCT Selectable	Photocell 0-10V Sensor Emergency
WPB3-120W	120W-100W-80W	100-277V/347V	135LM/W	16200LM	>80			

WPC2

10/

Full Cut-off Wall Pack

DLC 5.1 Premium Listed

- Die-Casting Aluminum Body
- High Lumens 130lm/w
- Photocell Optional
- Emergency Optional
- IP65 Wet Location



Distribution

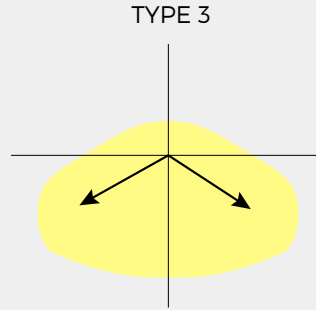
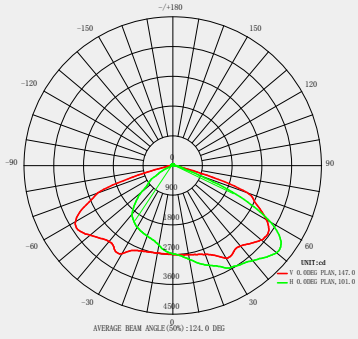

Dimension

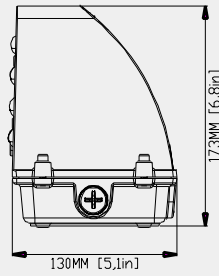
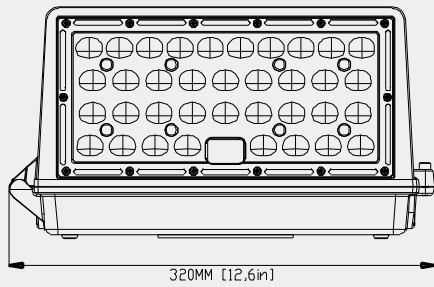

Advantage



Power 42W 60W 80W 100W



Photocell Optional (support Removable)



High efficiency Fresnel lens
Reach 130lm/w

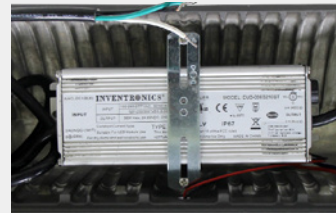

Multi Voltage 100-347Vac

Parameter

Model No.	Power	Input	Efficacy	Lumens	Ra	Beam Angle	CCT	Control
WP-42C2	42W	100-277V/347V	130LM/W	5200LM	>70	T3	3000K 4000K 5000K	Photocell 0-10V Sensor Emergency
WP-60C2	60W	100-277V/347V	130LM/W	7800LM	>70			
WP-80C2	80W	100-277V/347V	130LM/W	10400LM	>70			
WP-100C2	100W	100-277V/347V	130LM/W	13000LM	>70			

WPD2

11/

Adjustable Wall Pack

- DLC 5.1 Premium Listed
- ETL, cETL Listed
- High Lumens 140lm/w
- IP65 Wet Location
- Wall Mounted
- Photocell Optional
- Lifespan L70>100,000 Hours



Distribution

LUMINOUS INTENSITY DISTRIBUTION DIAGRAM

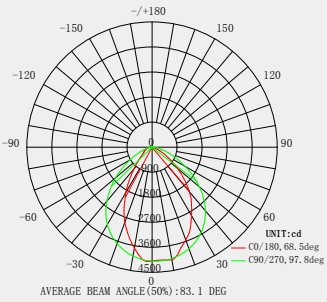

Dimension

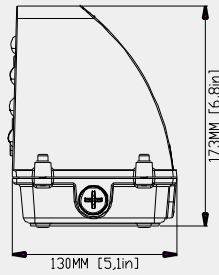
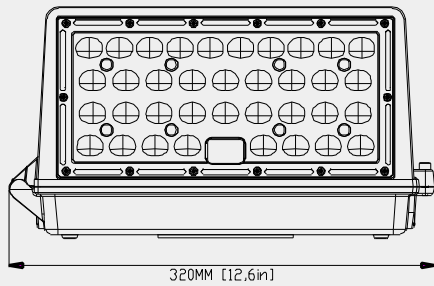

Advantage

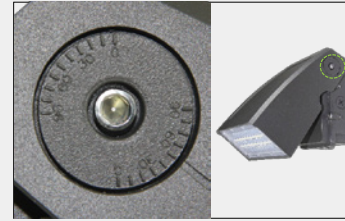

Adjustable 0-90°

“full cut-off” or “half cut-off” for your option
 There are adjustment scale at the side of lamp body for your easy adjusting

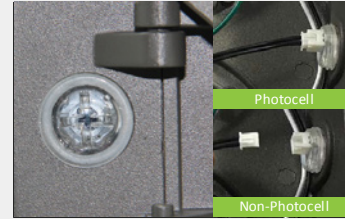

Photocell optional

Support Removable,
 Connect the terminal with photocell
 Remove the terminal without photocell



Multi-Volt: 100-277/347Vac

High Quality IP65 Waterproof Driver
 100-277Vac or 100-277/347Vac optional



Glare-Free Lens

High efficiency Fresnel lens
 luminous efficacy up to 120m/w
 Glare-Free to protect people eyes
 UV-Resistant, No yellowish worry

Parameter

Model No.	Power	Input	Efficacy	Lumens	Ra	Beam Angle	CCT	Control
WP-20D2	20W	100-277V/347V	130LM/W	2600LM	>70			
WP-30D2	30W	100-277V/347V	130LM/W	3900LM	>70			
WP-40D2	40W	100-277V/347V	130LM/W	5200LM	>70			
WP-60D2	60W	100-277V/347V	130LM/W	7800LM	>70	90°	3000K 4000K 5000K	Photocell 0-10V Sensor Emergency
WP-80D2	80W	100-277V/347V	130LM/W	10400LM	>70			
WP-100D2	100W	100-277V/347V	130LM/W	13000LM	>70			
WP-120D2	120W	100-277V/347V	130LM/W	15600LM	>70			

Smart Function optional



External Different Sensor Function



Sensor
(PIR or Microwave)

Remote control



Bluetooth Mesh Sensor
(PIR or Microwave)

APP/Wall Switch/Remote Control



Bluetooth SIG Mesh Sensor and dimming Control

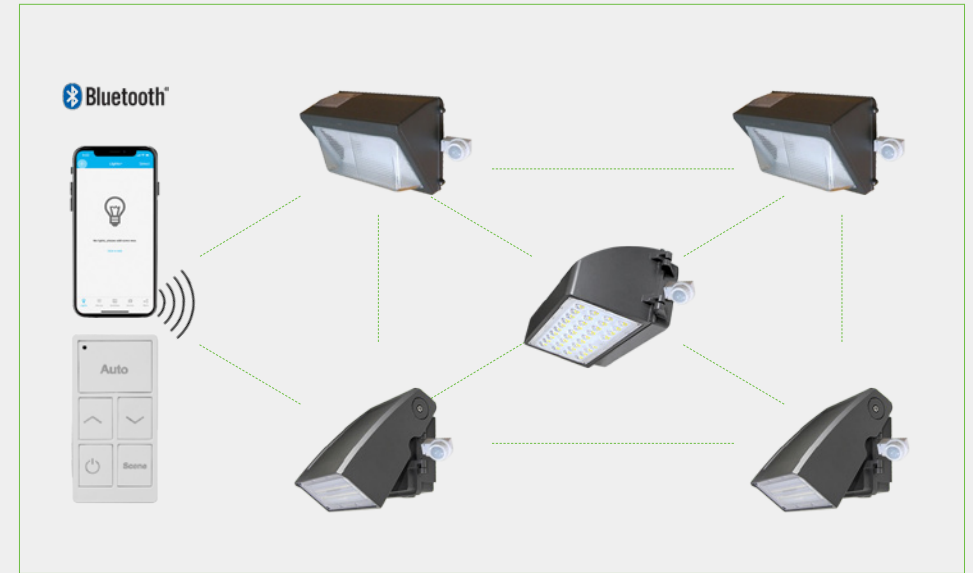

Wireless Bluetooth SIG Mesh between 30M/100FT
Distance of two Fixtures.



Group control, Support 100pcs in one Group.



Schedule and Timer, like 9:00AM ON, 18:00 OFF.



Scene Setting, like meeting, working etc.



Motion Sensor and Daylight harvest options,
automatically turn on, turn off and dim the lights.



Linkage, other lights in the same group detects movement, and the linkage is turned on in this group, then this light will dim to linkage light level.



Wireless Control and no need Hub



APP System is Easy to operated

Parking Garage Canopy



12

PGC



13

PGB



14

PGA



15

CNB



16

GSA

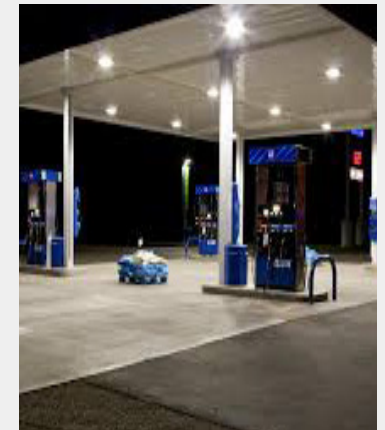
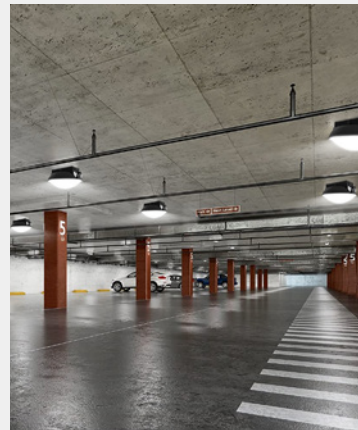
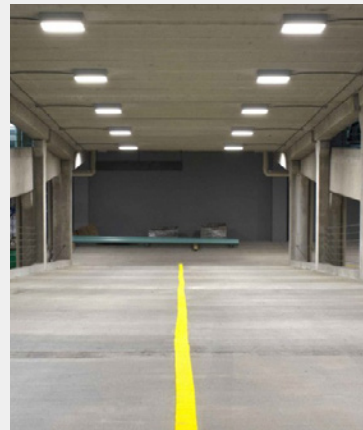

PGC

12/

Parking Garage Canopy

- DLC 5.1 Premium Listed
- 150° Beam Angle
- Plug & Play Motion
- 3-Power & 3-CCT Switchable
- 100-277V/ 347V available
- Can install EM driver
- Light transmission rate of lens is over 90%

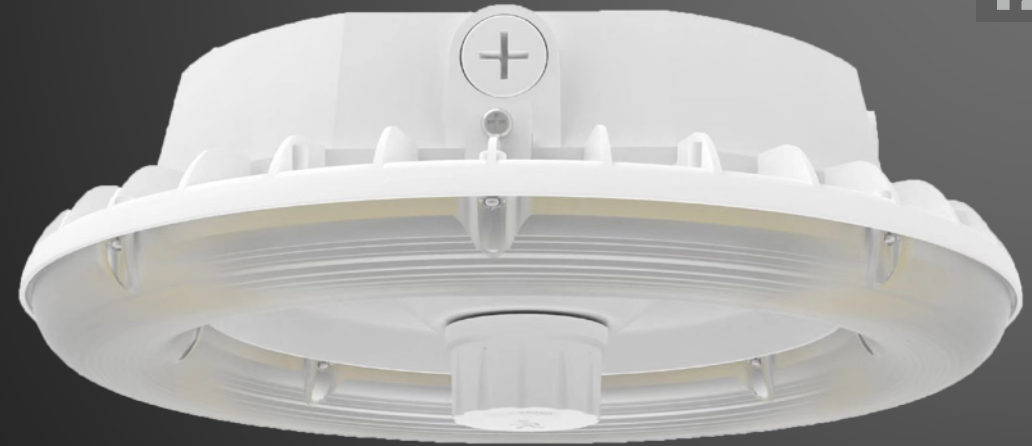

Distribution

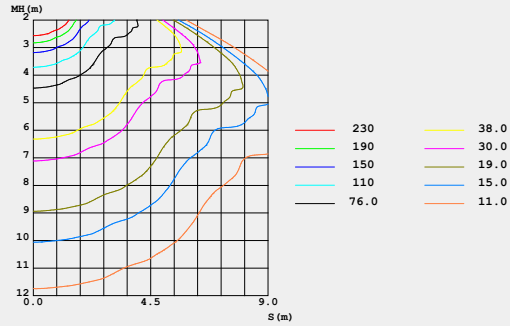
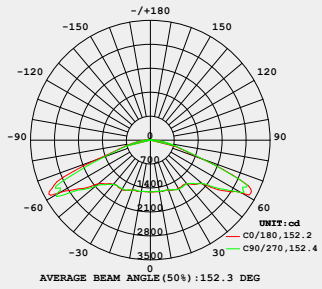

3-Power and 3-CCT Selectable

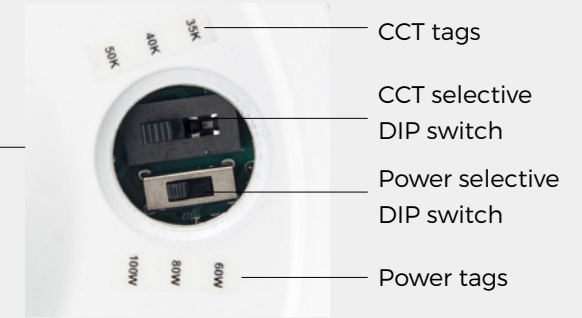

Dimension

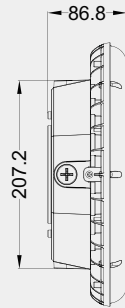
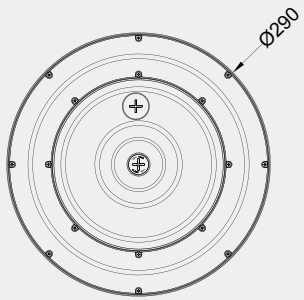

Plug & Play Sensor



Remote Control for resetting Sensor data or dimming

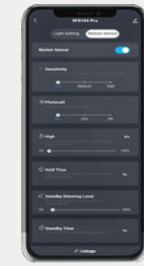

App Control Bluetooth



Wall Switch (Remote Control) Bluetooth

Parameter

Model No.	Power	Input	LEDs	Efficacy	Lumens	CCT	Angle	Control
PGC-40W	40W	100-277V/347V	2835	135LM/W	5400LM	Single color 3000K 4000K 5000K	150°	0-10V Sensor Bluetooth
PGC-60W	60W	100-277V/347V	2835	135LM/W	8100LM			
PGC-80W	80W	100-277V/347V	2835	135LM/W	10800LM			
PGC-80/60W/40W	80W/60W/40W Selectable	100-277V/347V	2835	135LM/W	10800LM	3-CCT Switchable		
PGC-100/80W/60W	100W/80W/60W Selectable	100-277V/347V	2835	135LM/W	13500LM			

PGB

13/

Parking Garage Canopy

- DLC 5.1 Premium Listed
- 150° Beam Angle
- Plug & Play Motion
- 3-Power & 3-CCT Switchable
- 100-277V/ 347V available
- Can install EM driver
- Light transmission rate of lens is over 90%

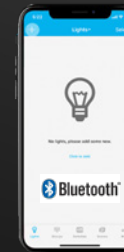
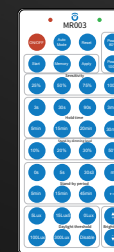

Distribution

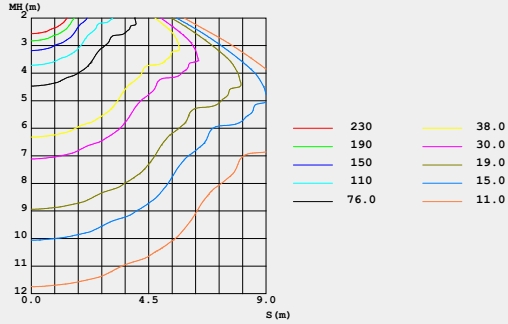
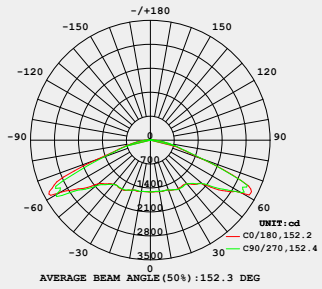

3-Power and 3-CCT Selectable

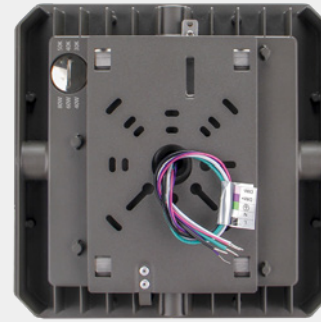

80W-60W-40W, 30K-40K-50K

Dimension

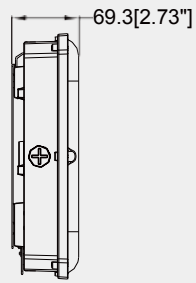
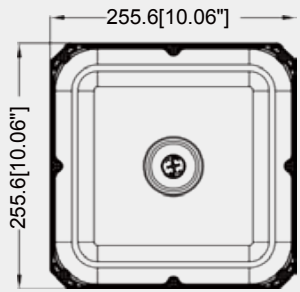

Plug & Play Sensor



Remote Control for resetting Sensor data or dimming

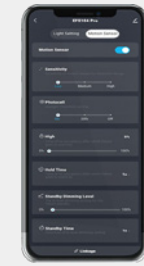

App Control Bluetooth



Wall Switch (Remote Control) Bluetooth

Parameter

Model No.	Power	Input	LEDs	Efficacy	Lumens	CCT	Angle	Control
GPB-40W	40W	100-277V/347V	2835	135LM/W	5400LM	Single color 3000K 4000K 5000K	150°	0-10V Sensor Bluetooth
GPB-60W	60W	100-277V/347V	2835	135LM/W	8100LM			
GPB-80W	80W	100-277V/347V	2835	135LM/W	10800LM			
GPB-80/60W/40W	80W/60W/40W Selectable	100-277V/347V	2835	135LM/W	10800LM	3-CCT Switchable		
GPB-100/80W/60W	100W/80W/60W Selectable	100-277V/347V	2835	135LM/W	13500LM			

PGA

14/

Parking Garage Canopy

- 170° Beam Angle
- IP65 Wet Location
- Luminous Efficacy 120lm/w
- Multi-Voltage: 100-277/347V
- 1-10V dimmable in standard
- Bi-level Sensor optional



Distribution

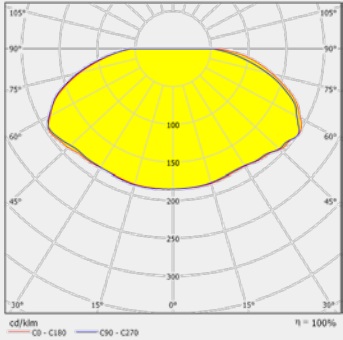

Dimension

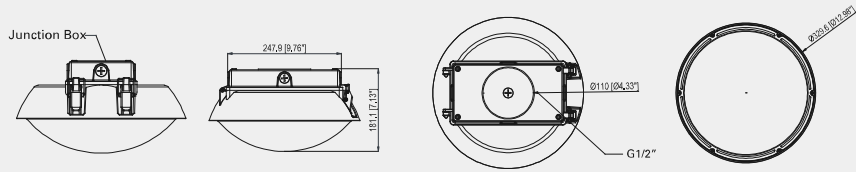

Advantage



Parameter

Model No.	Power	Input	LEDs	Efficacy	Lumens	Ra	Beam Angle	CCT	Control
PGA-40W	40W	100-277V/347V	3030	120LM/W	4800LM	>70	170°	3000K 4000K 5000K 5700K	0-10V Sensor Emergency
PGA-60W	60W	100-277V/347V	3030	120LM/W	7200LM	>70			
PGA-80W	80W	100-277V/347V	3030	120LM/W	9600LM	>70			
PGA-100W	100W	100-277V/347V	3030	120LM/W	12000LM	>70			

CNB

15/

Parking Garage Canopy

- ETL, cETL DLC Listed
- High Lumens Up to 120lm/w
- IP65 Wet Location
- Built-in Sensor optional
- High Quality driver
- 5 Years warranty



Distribution

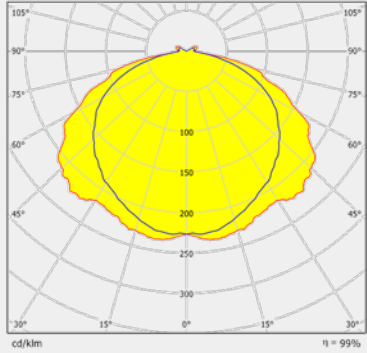

Dimension

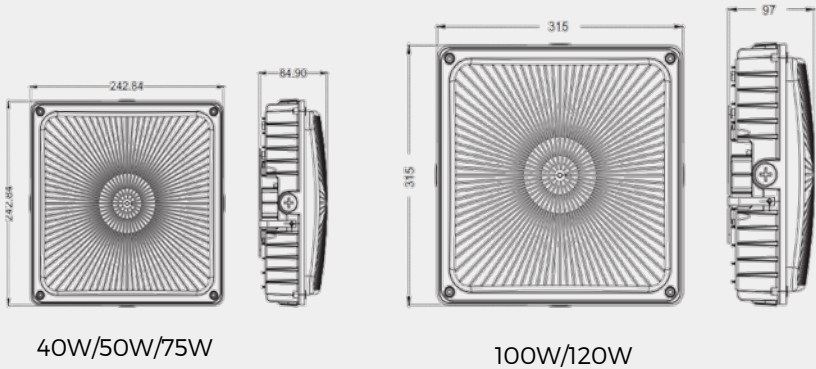

40W/50W/75W

100W/120W

Parameter

Model No.	Power	Input	LEDs	Efficacy	Lumens	Angle	CCT	Control
CNB-42W	40W	100-277V/347V	2835	130LM/W	5200LM	120°	3000K 4000K 5000K 5700K	0-10V Sensor Emergency
CNB-60W	60W	100-277V/347V	2835	130LM/W	7800LM			
CNB-80W	80W	100-277V/347V	2835	130LM/W	10400LM			
CNB-100W	100W	100-277V/347V	2835	130LM/W	13000LM			
CNB-120W	120W	100-277V/347V	2835	130LM/W	15600LM			

Different lens options



High Lumens

High light transmittance cover, high efficient SMD LED Chips.

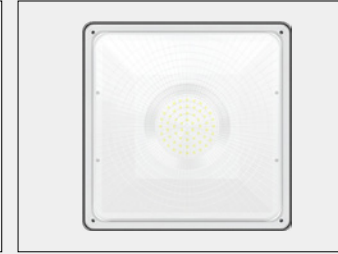

Shatterproof polycarbonate Lens

The high lumen output low profile design make the led canopy light ideal for building exteriors and parking garages.

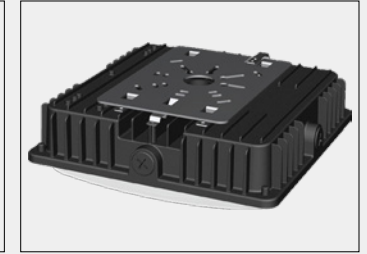

Installation Multiple Ways

Match J-BOX installation or Pole pendant installation



High Heat Dissipation Design

Die-casting aluminum heat sink For superior thermal performance and increased longevity

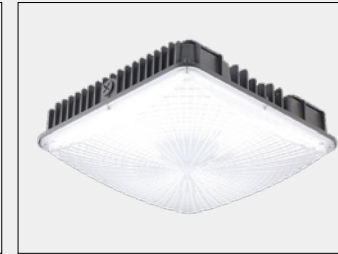

Super Bright

Luminous efficacy up to 120lm/w



Other function optional

1-10V dimmable optional
Motion Sensor optional
Photocell optional

GSA

16/

Gas Station Light

- DLC 5.1 Premium Listed
- Luminous Efficacy 130lm/w
- IP65 Wet Location
- Multi-Voltage: 100-277/347V
- 1-10V dimming in standard
- Integrated driver, easy to install and operate.

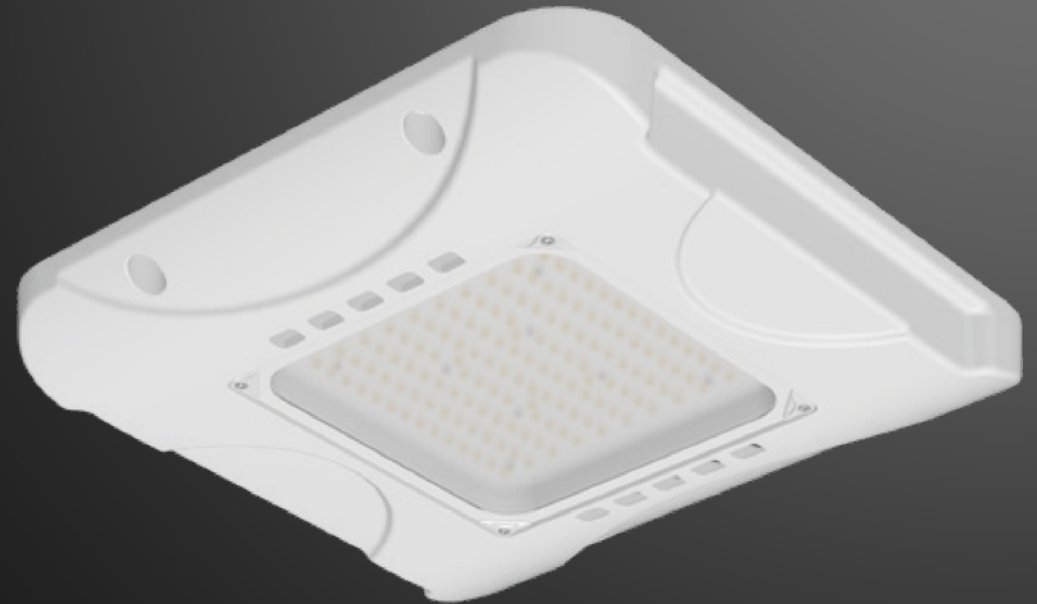

Distribution

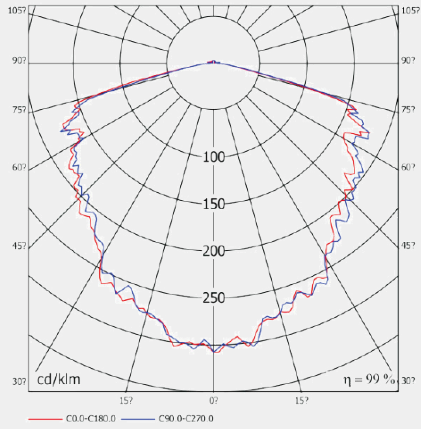

Dimension

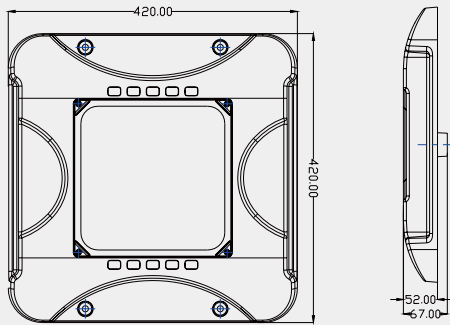

Parameter

Model No.	Power	Input	Efficacy	Lumens	Angle	CCT	Control
GSA-100W	100W	100-277/347V	140LM/W	14000LM	120°	3000K 4000K 5000K	0-10V Dim
GSA-150W	150W	100-277/347V	140LM/W	21000LM			
GSA-200W	200W	100-277/347V	140LM/W	28000LM			
GSA-240W	240W	100-277/347V	140LM/W	33600LM			

Advantage

High light transmittance glass lens

The high lumen output and low profile design make the LED canopy light ideal for building exteriors and parking garages.

High efficient SMD LED chips

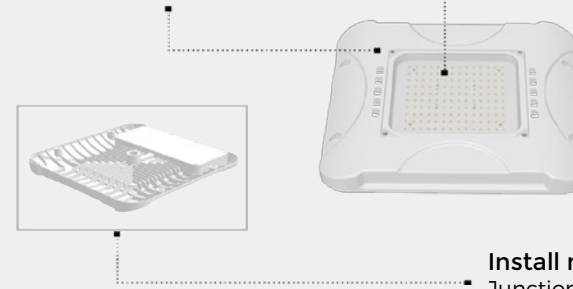

Install multiple ways

Junction Box / Conduit Nuts / Surface mounted

Installation

Ceiling Installation

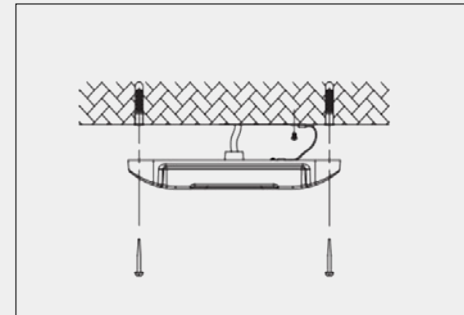

Pole-pendant Installation

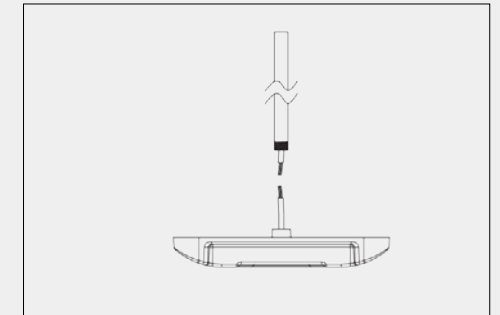

Smart Function optional



Plus & Play different cover for different function



Sensor
(PIR or Microwave)

Remote control



Bluetooth Mesh Sensor
(PIR or Microwave)



APP/Wall Switch/Remote Control

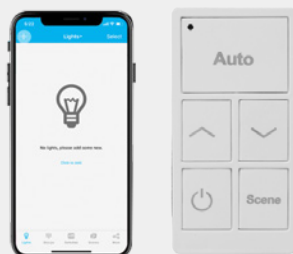

Bluetooth SIG Mesh Sensor and dimming Control



Wireless Bluetooth SIG Mesh between 30M/100FT
Distance of two Fixtures.



Group control, Support 100pcs in one Group.



Schedule and Timer, like 9:00AM ON, 18:00 OFF.



Scene Setting, like meeting, working etc.



Motion Sensor and Daylight harvest options,
automatically turn on, turn off and dim the lights.



Linkage, other lights in the same group detects movement, and the linkage is turned on in this group, then this light will dim to linkage light level.



Wireless Control and no need Hub



APP System is Easy to operated