

# ENGEL

MODEL	INPUT
SB70F	DC12/24V
SR48F	AC120V, DC12/24V
SR70F	
ST90F	

## REFRIGERATOR

### INSTALLATION AND OWNER'S MANUAL

Model No. \_\_\_\_\_

Serial No. \_\_\_\_\_

**SAWAFUJI ELECTRIC CO., LTD.**

TOKYO, JAPAN

(Cat.No.5490 303 2000)

Printed in Thailand

## Safety Awareness

Read this manual carefully and understand the contents before you install the refrigerator.

Be aware of possible safety hazards when you see the safety alert symbol on the refrigerator and in this manual. A signal word follows the safety alert symbol and identifies the danger of the hazard. Carefully read the descriptions of these signal words to fully know their meanings. They are for your safety.



**WARNING:** This signal word means a hazard, which if ignored, can cause dangerous personal injury, death, or much property damage.



**CAUTION:** This signal word means a hazard, which if ignored, can cause small personal injury or much property damage.

## Model No. and Serial No.

The model and serial number are on a label which is inside the refrigerator on the left side and on the cover of this manual.

## Operation (Except Model SB70F)

This refrigerator is made for refrigerating purposes and operates on 120 volts AC and 12/24 volts DC power supplies when installed as written in this manual.

**NOTE:** The refrigerator operates automatically on AC or DC power. When both power sources are supplied to the refrigerator, it defaults to AC. When the refrigerator is disconnected from the shoreline power (when AC power is no longer available), the refrigerator switches to DC operation.



**CAUTION:** Never store combustible materials near the refrigerator. Storing combustible materials near the refrigerator creates a safety hazard and also decreases the ventilation of the cooling system which decreases the refrigerator performance.

Do not touch the evaporator or other metal parts inside the refrigerator cabinet with wet hands because they can freeze to the refrigerator.

Always disconnect all power sources from the refrigerator when doing routine maintenance. Have service work done only by a qualified service technician.

The refrigerator temperature is controlled by a thermostat, located on the panel above the door. A green power light, located on the panel comes on when the refrigerator is "ON". Number "1" is the warmest and number "5" is the coldest thermostat position. For efficient operation, change the thermostat according to the types of food stored and the ambient temperature.

If you are not going to use the refrigerator for an extended period of time, put the thermostat to the "OFF".

# Cleaning and Defrosting

## Defrosting

It is normal for frost to collect on the freezer plate inside the refrigerator. Excess frost decreases the cooling performance of the refrigerator. Defrost the refrigerator as necessary.



**CAUTION:** Do not use sharp objects, a hair dryer, a heat gun, etc. to defrost the refrigerator. Damage to the interior of the refrigerator can occur.

- Turn the thermostat to "OFF".
- Remove all food from the refrigerator.

**NOTE:** Defrosting the refrigerator makes excess water inside the refrigerator.

- Put dry towels (etc.) inside the refrigerator to absorb the excess water.
- Put trays of hot water in the freezer until the frost is melted.
- Empty the drip tray.
- Remove the wet towels (etc.) and dry the inside of the refrigerator
- Turn the thermostat to the desired setting.
- Put the drip tray and all food in the refrigerator.

## Cleaning

A good time to clean the refrigerator is just after you defrost it.

Clean the inside of the refrigerator as often as necessary to avoid food odors:

- Remove all food from the refrigerator.

**NOTE:** Do not use abrasive cleaners, chemicals, or scouring pads because they can damage the inside of the refrigerator.

- Wash the inside of the refrigerator and the door gasket with a solution of liquid dish detergent and warm water.
- Rinse with clean water and dry.
- After cleaning, put a thin coating of petroleum jelly on the hinge side of the gasket to keep it soft and to prevent it from rolling.

## Battery Maintenance

### Over cooling drains your battery

- When the ambient temperature is between 70° and 90° F, keep the thermostat at the “3” position to avoid an excessive drain of the battery. When making ice, or storing frozen foods, turn the thermostat to the coldest setting “5”.

### Maintain the battery

If the charge of your battery is not sufficient, the cooling performance of your refrigerator decreases.



**CAUTION:** Only use a “quick charger” on the battery if the thermostat is turned to “OFF”.

### Check the Battery charge Level

A fully charged battery will have a specific gravity reading of between 1.260 and 1.280. The battery voltage is best indicated when the refrigerator is “ON” and the battery charging system is “OFF”. Charge the battery when the specific gravity reading is less than 1.200.

## For your reference

The wiring diagram shown below is recommended for dual battery hookup (See Art01516).

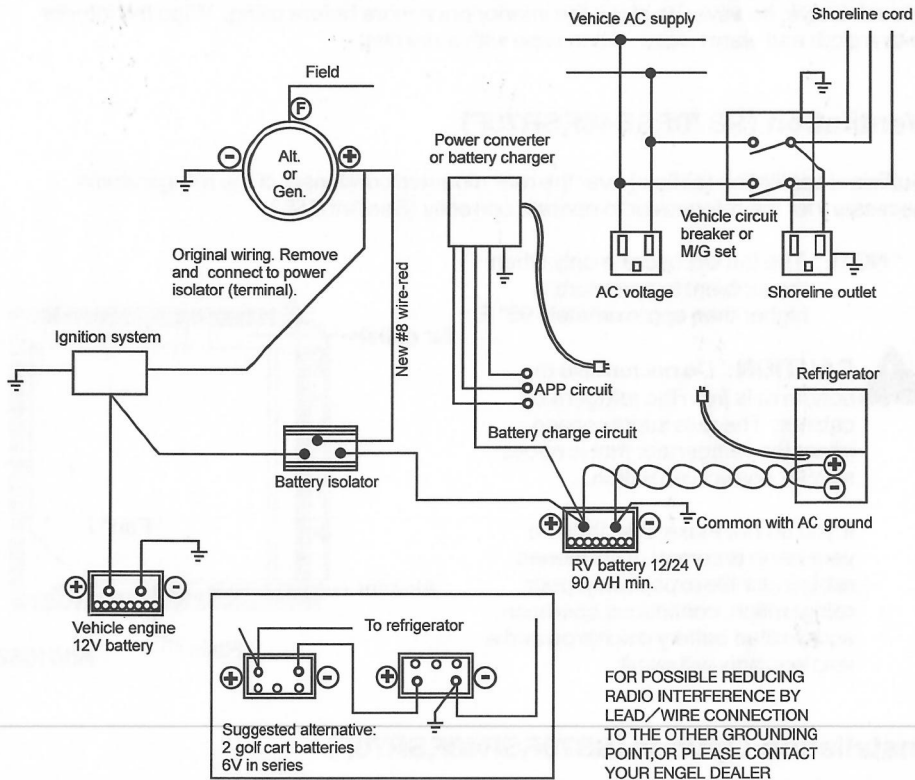

Art01516

## Installation (SB70F,SR48F,SR70F)

The refrigerator should be located and secured on a solid surface in the vehicle.

Before installing the refrigerator into the opening, make sure the DC supply is properly connected. In many cases, the DC supply can be connected from outside the vehicle by means of the baggage or access door.

Measure the opening to determine if you have proper clearance for installation. Additional insulation space around the refrigerator is not necessary.

Be sure the refrigerator is not in direct sunlight or near a gas stove, a heater, or other heat-generating appliances. Avoid installing your refrigerator close to warm water lines or warm air ducts.

Your refrigerator was thoroughly cleaned before shipment from the factory. It is advisable, however, to clean the interior once more before using. Wipe the interior with a cloth and warm water. Then wipe with a dry cloth.

## Ventilation (SB70F,SR48F,SR70F)

Sufficient ventilation (airflow) over the rear mounted condenser of the refrigerator is necessary for the refrigerator to operate correctly (See Art01582).

\* NOTE: The fan will operate only when the ambient temperature is higher than approximately 95° F.

**CAUTION:** Do not remove the bottom rails from the refrigerator cabinet. The rails supply space under the refrigerator that is necessary for correct ventilation.

If you do not make sure that the ventilation is correct, a shortened refrigerator life expectancy, poor refrigeration, continuous operation, accelerated battery discharge and a void warranty will result.

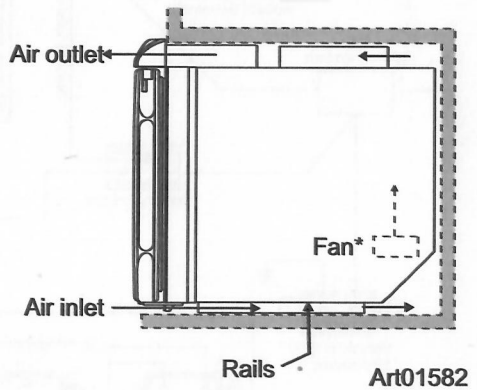

## Installation Options (SB70F,SR48F,SR70F)

### Install a decorative door panel

NOTE: The decorative door panel must be 4 mm or less in thickness.

1. Remove the door from the refrigerator by removing the two (2) bolts that attach the door hinge to the bottom of the refrigerator (See Art01583).

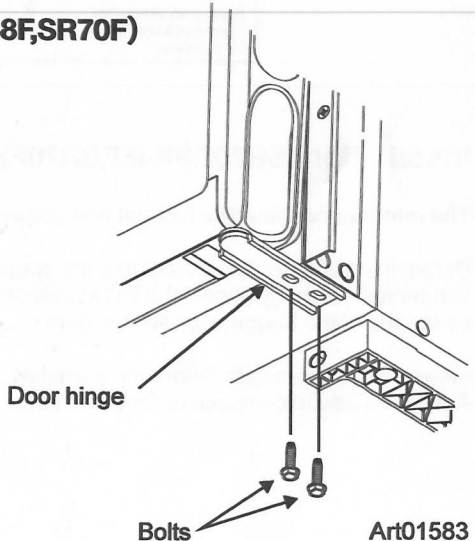

2. Remove the panel retainer by removing the two (2) screws that attach the panel retainer (See Art01511).
3. Gently pull the door panel out of the door (Art01512).
4. Push a new door panel into the door slot.

**CAUTION:** Do not overtighten the screws and bolts.

5. Put the panel retainer in the original location and attach with two (2) screws.
6. Put the door in the original location and tighten the two (2) bolts.

### Reverse the door swing:

1. Remove the door from the refrigerator by removing the two (2) bolts that attach the door hinge to the bottom of the refrigerator
2. Remove the two (2) bolts that attach the upper hinge.
3. Remove the bolt that attaches the door latch plate to the top of the refrigerator (See Art01513).
4. Remove the upper hinge and the door latch plate from the refrigerator.
5. Attach the upper hinge and the door latch plate to the opposite sides of the refrigerator.

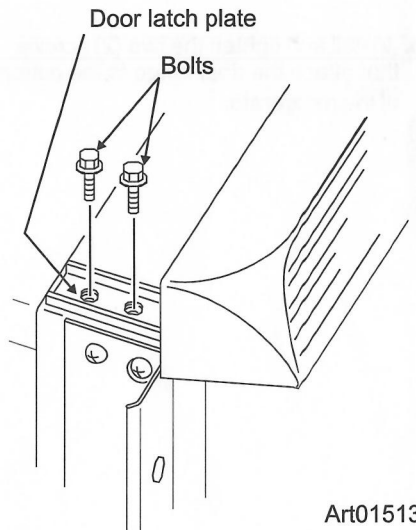
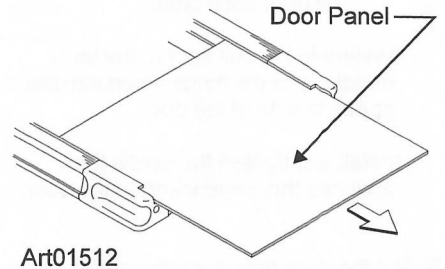
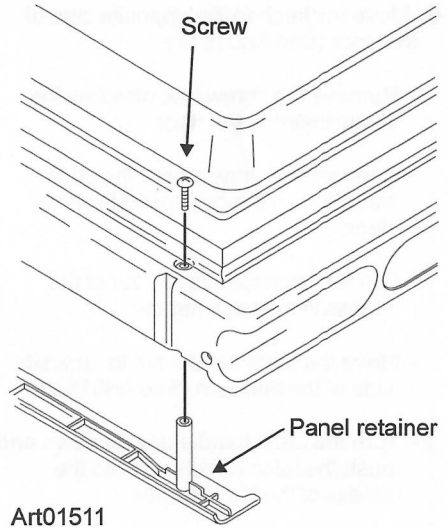

Art01513

6. Move the latch to the opposite side of the door (See Art01514):

- Remove the screw that attaches the hinge insert to the door.
- Remove the hinge insert, the latch handle, and the coil spring from the door.
- Pull the latch handle pin out of the recess in the latch handle.
- Move the latch handle pin to opposite side of the latch pin (See Art01515).
- Turn the latch handle upside down and push the latch handle pin into the recess of the latch handle.
  - Make sure the angled top faces the door latch plate.
- Assemble the coil spring, the latch handle, and the hinge insert into the opposite side of the door.
- Install and tighten the screw that attaches the hinge insert to the door.

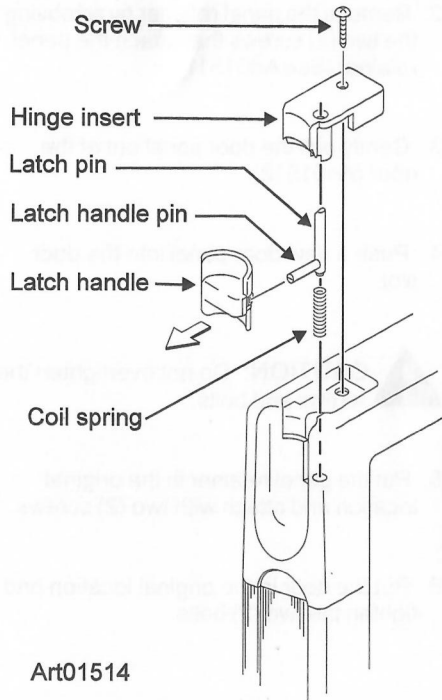

Art01514

7. Put the door onto the refrigerator

8. Install and tighten the two (2) screws that attach the door hinge to the bottom of the refrigerator.

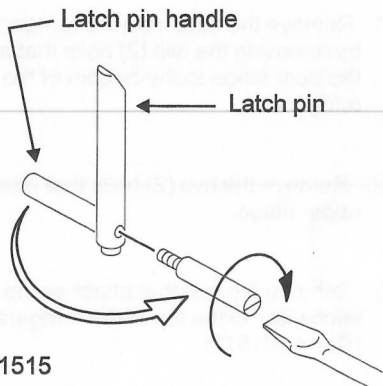

Art01515



## Connect the 120 volts AC and 12 volts DC supplies

This refrigerator operates on 120 volts (60 hertz) AC current and 12/24 volts DC current from a battery.

**CAUTION:** Only connect the refrigerator directly to the battery. Because they often generate high voltage pulses and cause transistor defects in the inverter, no other switches, lead wires, or electrical equipment should share the wiring between the refrigerator and battery. Do not use an extension cord.

When using either a converter or a battery charger, make sure that they are connected in parallel between the battery and the refrigerator. Do not use a converter or battery charger to supply the DC power directly to the refrigerator because these two devices do not supply filtered DC power (See Art01521).

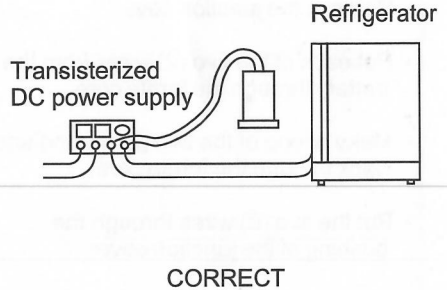
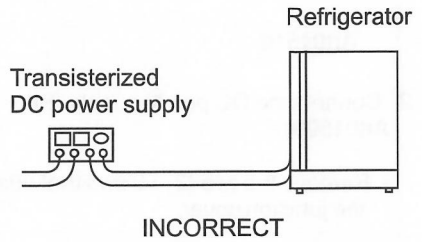
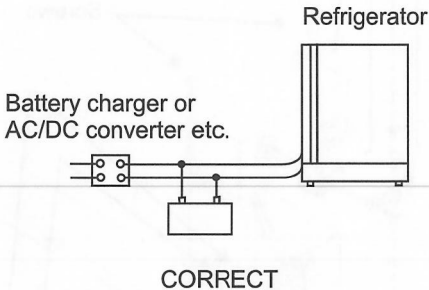
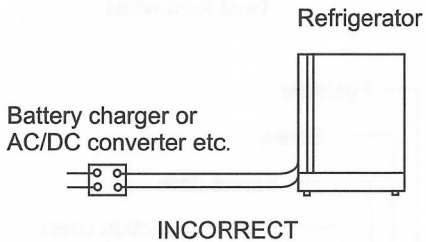

Art01521

As the distance from the vehicle battery to the refrigerator increases, the correct AWG wire size also increases. If the wire size is too small for the distance, a voltage drop occurs. The voltage drop decreases the cooling performance of the refrigerator.

1. We recommends that you use the following wire and fuse sizes:

- Measure the distance from the vehicle battery to the refrigerator:

- If the distance is less than 12 feet, use 16 AWG wire and a 10 Amp fuse.
- If the distance is between 12 and 20 feet, use 14 AWG wire and a 10 Amp fuse.
- If the distance is more than 20 feet, use 12 AWG wire and a 10 Amp fuse.

- Twist the lead wires to reduce the radio interference and induction of a high voltage surge from the outside (See Art01518).

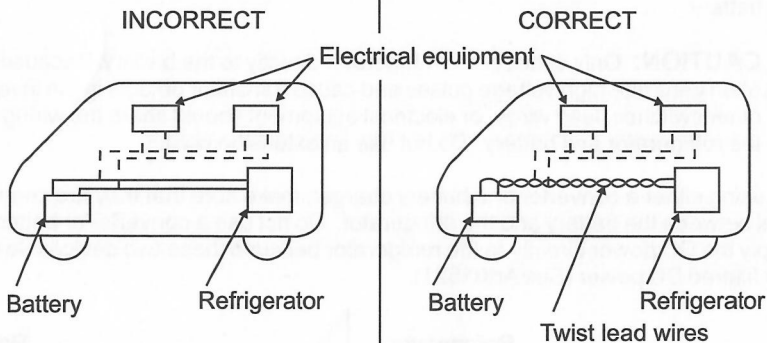

Art01518

2. Connect the DC power supply (See Art01509):

- Remove the two (2) screws that attach the junction cover.
- Remove the junction cover.
- Put each of the two (2) wires from the battery through the ferrite core.
- Make a loop of the two (2) around and back through the ferrite core.
- Put the two (2) wires through the bushing of the junction cover.
- Push the DC input wires onto the DC input terminals.
  - Refer to the positive (+) and negative (-) markings to make sure that the connections are correct.
- Attach the junction cover with the two (2) screws.
- Put the two (2) wires through the wire strain relief.
- Attach the wire strain relief to the refrigerator cabinet with the self-tapping screw.

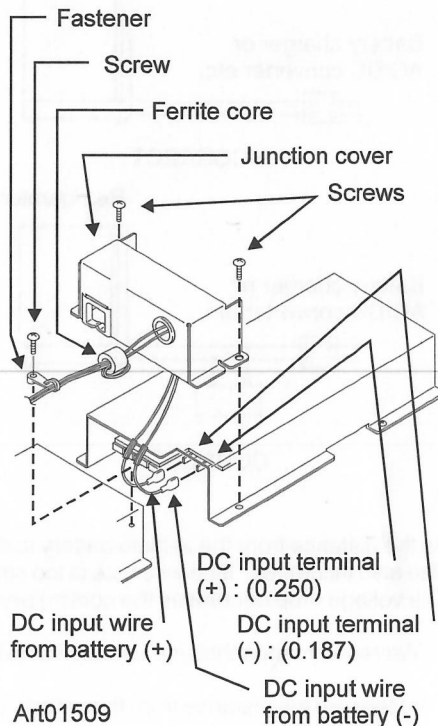

## Installation(ST90F)

The refrigerator should be located and secured on a solid surface in the vehicle and boats.

Before installing the refrigerator into the opening, make sure the DC supply is properly connected.

Measure the opening to determine if you have proper clearance for installation. Additional insulation space around the refrigerator is not necessary

Be sure the refrigerator is not in direct sunlight or near a gas stove, a heater, or other heat-generating appliances. Avoid installing your refrigerator close to warm water lines or warm air ducts.

Your refrigerator was thoroughly cleaned before shipment from the factory. It is advisable, however, to clean the interior once more before using. Wipe the interior with a cloth and warm water. Then wipe with a dry cloth.

## Ventilation(ST90F)

Sufficient ventilation (airflow) over the rear mounted condenser of the refrigerator is necessary for the refrigerator to operate correctly. Use any of the following combinations of vent openings: A-D, A-I, A-J, B-C, B-F, B-H, C-D, C-I, C-J, D-F, D-H, F-I, F-J, G-I, G-J, H-I, H-J (See Art01129).

For the minimum required ventilation, each individual vent opening should be no less than 50 square inches. However, the vent openings should be larger, to allow as much ventilation as possible. The more air that circulates over the refrigerator condenser, the more efficiently the refrigerator will operate.

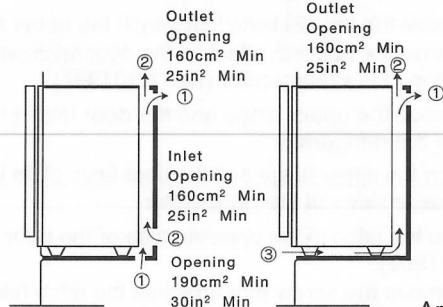
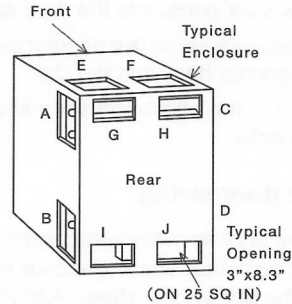

Art01129

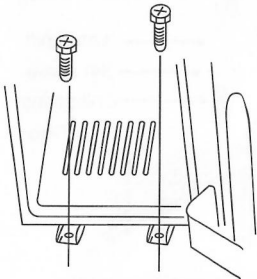

**CAUTION:** Do not remove the bottom rails from the refrigerator cabinet. The rails supply space under the refrigerator that is necessary for correct ventilation.

If you do not make sure that the ventilation is correct, a shortened refrigerator life expectancy, poor refrigeration, continuous operation, accelerated battery discharge and a void warranty will result.

## Installation Options(ST90F)

### Install a decorative door panel

NOTE: The decorative door panel must be 4 mm or less in thickness.

1. Remove the door from the refrigerator by removing the two (2) bolts that attach the door hinge to the top of the refrigerator (See Art01986).
2. Lift the door off the bottom hinge.
3. Remove the panel retainer by prying the retainer out of the slot (See Art01985).
4. Gently pull the door panel out of the door.
5. Push a new door panel into the door slot.
6. Put the panel retainer in the original location and press the retainer back into the slot.
7. Put the door in the original location and tighten the two (2) bolts.

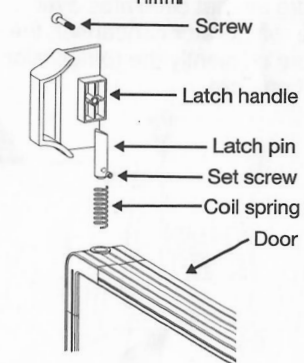
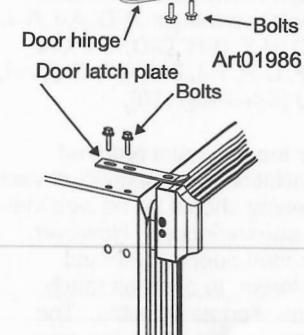
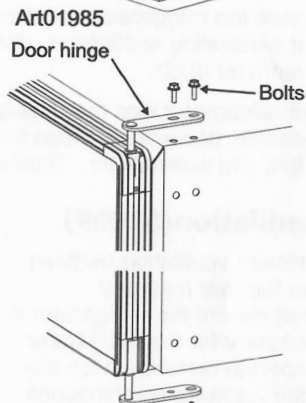
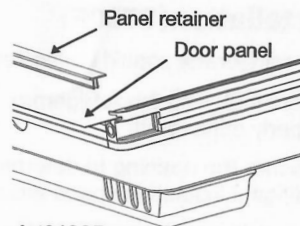

### Reverse the door swing:

1. Remove the door from the refrigerator by removing the two (2) bolts that attach the door hinge to the bottom of the refrigerator (See Art01986).
2. Remove the two (2) bolts that attach the upper hinge.
3. Remove the bolt that attaches the door latch plate to the top of the refrigerator (See Art01987).
4. Remove the upper hinge and the door latch plate from the refrigerator.
5. Attach the upper hinge and the door latch plate to the opposite sides of the refrigerator.
6. Move the latch to the opposite side of the door (See Art01988):
  - Remove the screw that attaches the latch handle and the latch pin.
  - Remove the latch handle pin and the coil spring from the door.
  - Move the set screw to opposite side of the latch pin.
  - Assemble the coil spring and the latch pin into the opposite side of the door.
  - Attach the handle to the latch pin.
  - Make sure that the angled end of the latch pin is up.
7. Put the door onto the refrigerator and make sure that the gasket seals correctly
8. Install and tighten the two (2) screws that attach the door hinge to the bottom of the refrigerator.