



ENGEL

PARTS LIST

MODEL:

SB30G

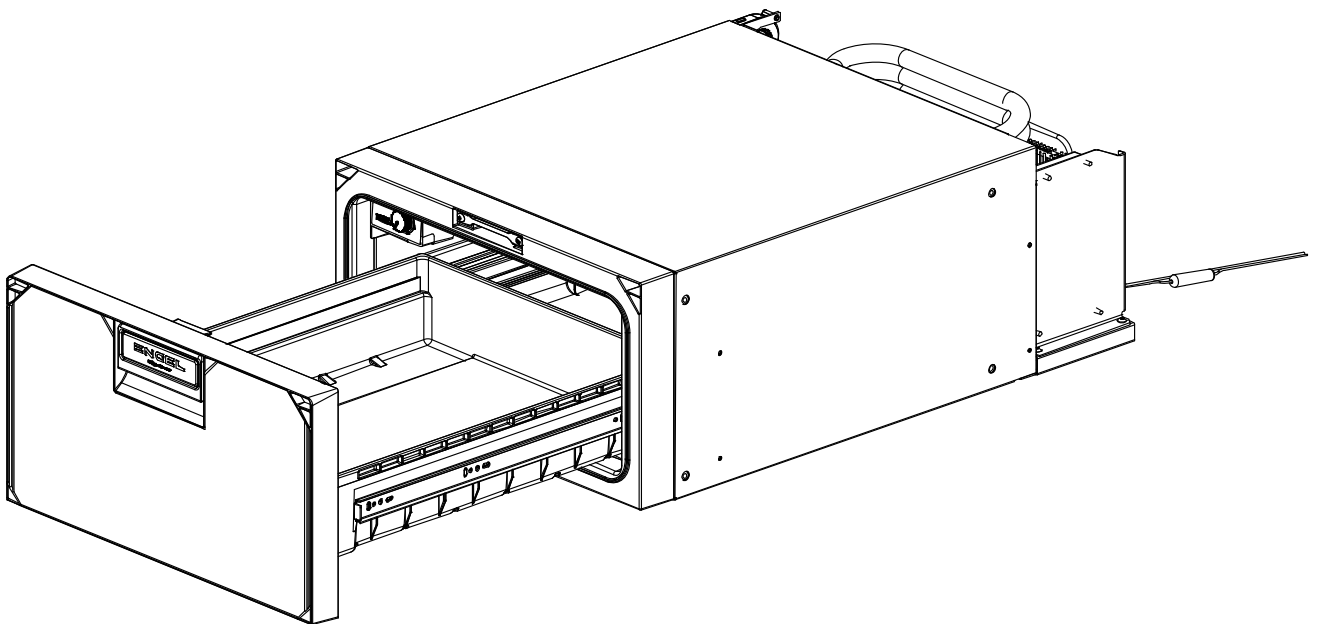

SAWAFUJI ELECTRIC

SB30G

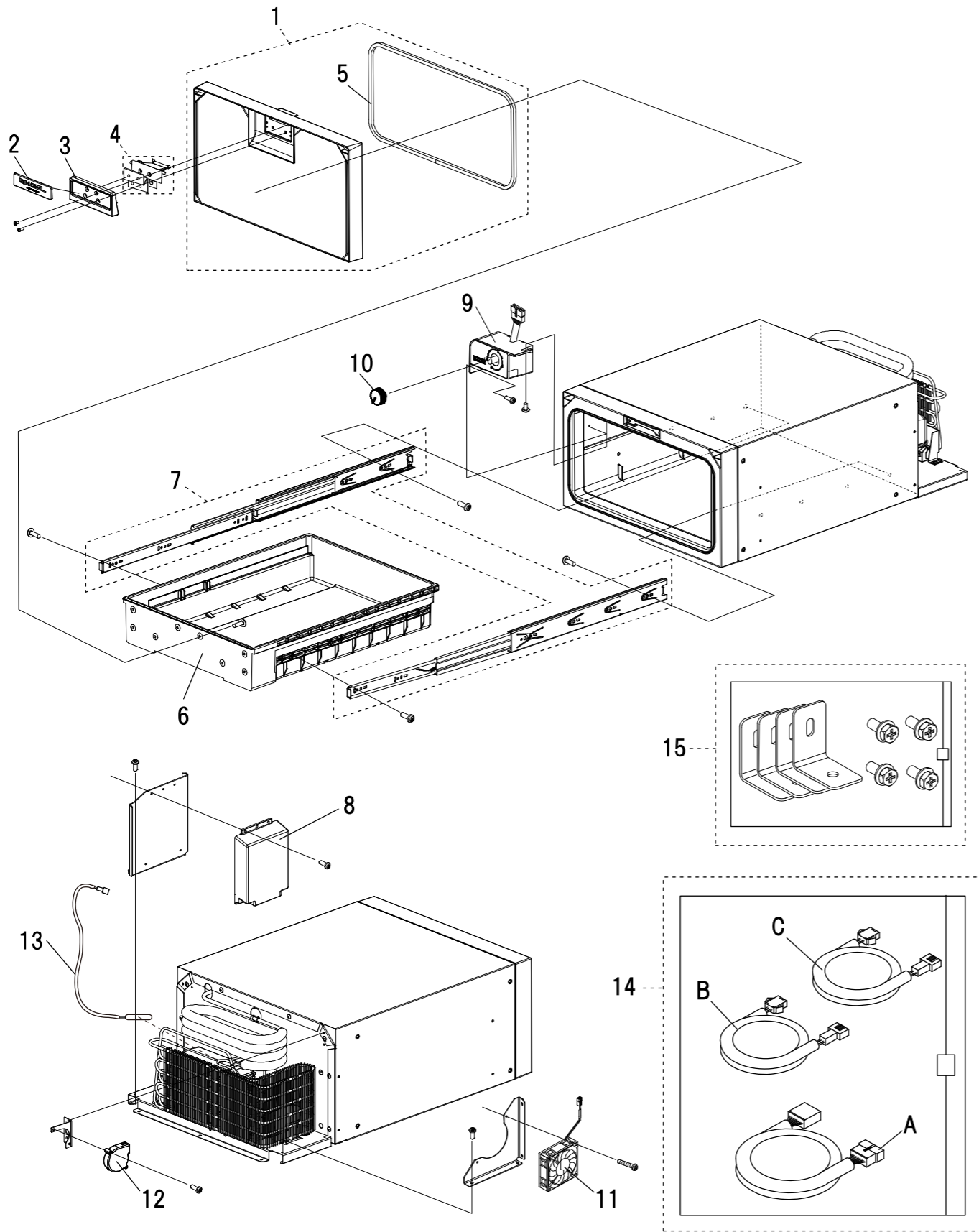

QTY SECTION	MODEL	MODEL CODE	PRODUCTION PERIOD	UNIT TYPE	REMARKS
A	SB30G	0643 030 120X	2016.~	RC40	
	SB30G-L-A	0643 030 2200	2018.~	RC40	
	SB30G-R-A	0643 030 2210	2018.~	RC40	
B	SB30G-W	0643 030 1210	2018.~	RC40	

ITEM NO.	DESCRIPTION	ITEM CODE	QTY Used per fridge		QTY included per item code	REMARKS
			A	B		
1	DOOR ASSY	1609 520 00X9	1	-	1	
	DOOR ASSY	1610 520 00X8	-	1	1	
2	MARK (ENGEL)	5450 821 00X9	1	1	5	
3	HANDLE (Door Latch)	4225 163 00X9	1	1	1	
4	LATCH ASSY (Door Latch)	1609 521 00X9	1	1	1	
5	PACKING (Door)	4141 309 10X9	1	1	1	
6	CASE (Tray)	4225 162 00X9	1	1	1	
7	SLIDE RAIL	6269 031 00X9	2	1	1 SET	
8	POWER SUPPLY (RC40)	1601 214 12X9	1	-	1	
	POWER SUPPLY (RC40)	1601 214 30X9	-	1	1	
9	CONTROL ASSY	1601 219 00X9	1	1	1	Mark included
10	DIAL ASSY	1602 067 10X9	1	1	5	
11	FAN MOTOR ASSY (Cooling Fan)	1609 289 20X9	1	1	1	
12	FAN MOTOR (Blower Fan)	6080 031 10X9	1	1	1	
13	THERMISTOR (Ambient Temperature)	6055 075 00X9	1	1	1	
14	CORD SET 1A - Coupler Assy 7P (For Controller) 1B - Coupler Assy 3P (For Thermistor) 1C - Coupler Assy 2P (For Fan Motor)	1699 023 00X0	1	1	1 SET	OPTION
15	L PLATE (Cabinet)	3220 761 00X9	1	1	1 SET	