

# MT60F-U1 / MT80F-U1

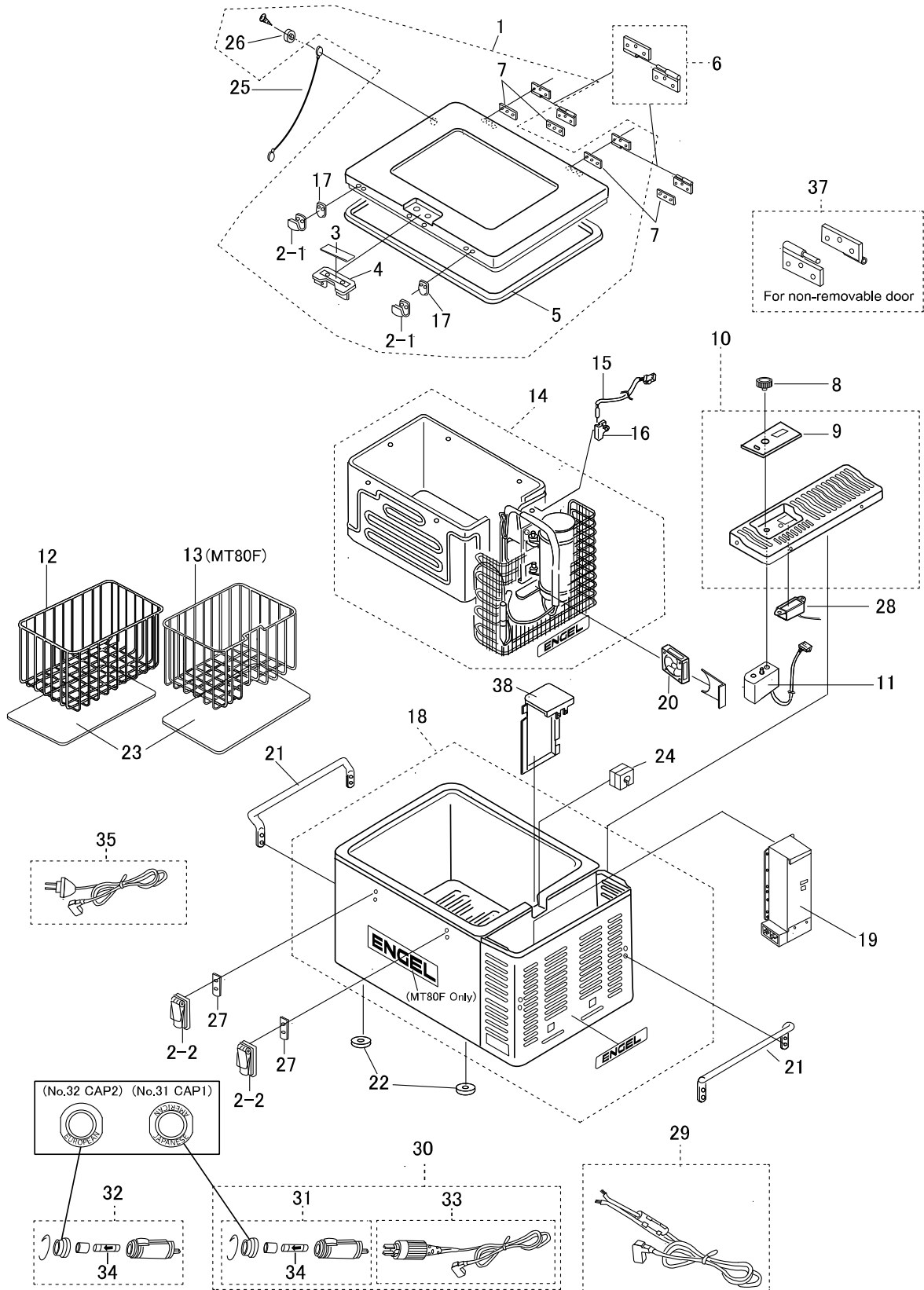

QTY SECTION	MODEL	MODEL CODE	PRODUCTION PERIOD	UNIT TYPE	REMARKS
A	MT60F-U1	0642 060 1R21	2003.03~	N21	
B	MT80F-U1-S	0642 080 1R01	2007.07~	N21	
C					

ITEM NO.	DESCRIPTION	ITEM CODE	QTY			QTY included per item code	REMARKS
			Used per fridge				
			A	B	C		
1	DOOR ASSY ( Dark Gray Leather )	1600 555 40X9	1	-		1	FCM (Food Contact Materials)
	DOOR ASSY ( Silver Metallic )	1600 555 30X9	-	1		1	FCM (Food Contact Materials)
2-1	LATCH ASSY ( 1 set = 2-1 & 2-2 )	1609 356 10X9	2	2		1 set	
2-2							
3	MARK ( Handle )	5450 821 00X9	1	1		5	
4	HANDLE ( Door )	4225 004 01X9	1	1		1	
5	GASKET	4148 031 20X9	1	1		1	
6	HINGE ASSY (Removable)	1609 061 00X9	2 sets	2 sets		1 set	
7	I PLATE ( Hinge )	4301 118 10X9	4	4		8	
8	DIAL ASSY	1602 067 00X8	1	1		5	
9	MARK ( Temperature Control )	5450 261 60X9	1	-		5	
		5450 891 21X9	-	1		10	
10	MOTOR COVER ASSY( Dark Gray Leather )	1602 078 00X8	1	-		1	
	MOTOR COVER ASSY( Dark Silver )	1602 278 20X8	-	1		1	
11	CONTROL ASSY	1601 169 00X9	1	-		1	
		1601 169 40X9	-	1		1	
12	BASKET	5230 018 10X9	2	-		1	
		5230 049 10X9	-	1		1	
13	BASKET ( Compressor Side )	5230 052 10X9	-	1		1	
14	COOLING UNIT	1610 136 20X9	1	-		1	
		1610 140 00X9	-	1		1	
15	THERMISTOR	6055 081 30X9	1	-		1	Order and replace the thermistor and holder as a set.
		6055 054 20X9	-	1		1	
16	INSULATION HOLDER	4223 050 20X9	1	1		1	
17	I PLATE ( Latch )	4301 129 00X9	2	2		4	
18	CABINET ASSY ( Light Gray Leather )	1600 628 10X9	1	-		1	FCM (Food Contact Materials)
		1600 549 20X9	-	1		1	FCM (Food Contact Materials)
19	POWER SUPPLY	1601 176 00X9	1	1		1	
20	FAN MOTOR ASSY	1609 289 00X9	1	1		1	
21	HANDLE ( Cabinet ) ( Light Gray )	3233 005 40X9	1 set	-		2	1set= HANDLE 2 Pieces
	HANDLE ( Cabinet ) ( Silver Metallic )	3233 009 30X9	-	1 set		2	1set= HANDLE 2 Pieces
22	CUSHION ( Rubber Leg )	4120 139 00X9	1 set	1 set		4	1set= CUSHION 4 Pieces
23	I SHEET ( Wide )	4303 048 00X9	-	2		1	
24	RUBBER BUSHING	4160 063 10X9	1	1		1	
25	CHAIN ASSY	1609 063 00X0	1	1		1	
26	HOLDER	3604 030 00X0	1	1		1	
27	I PLATE ( Cabinet )	4301 130 00X9	2	2		5	
28	THERMOMETER	6240 005 40X9	-	1		1	
29	CORD ASSY ( DC )	1912 422 10X0	1	1		1	
30	CORD ASSY ( Plug Type )	1912 404 00X9	Opt	Opt		1	
31	PLUG ASSY ( CAP1 )	1602 121 00X9	Opt	Opt		1	
32	PLUG ASSY ( CAP2 )	1602 121 10X9	Opt	Opt		1	
33	CORD ASSY ( Without Plug Assy )	1912 401 00X9	Opt	Opt		1	
34	FUSE ASSY ( Thermal 10A )	1603 002 00X9	Opt	Opt		1	
35	CORD ASSY ( AC )	1912 417 00X0	1	1		1	
37	HINGE ASSY ( Reverse )	1609 061 10X9	Opt	Opt		1 set	
38	COVER PIPE	4330 050 20X9	1	-		1	
		4330 048 20X9	-	1		1	