



N21

ENGEL

SERVICE MANUAL

F SERIES MODEL

MT60F-U1

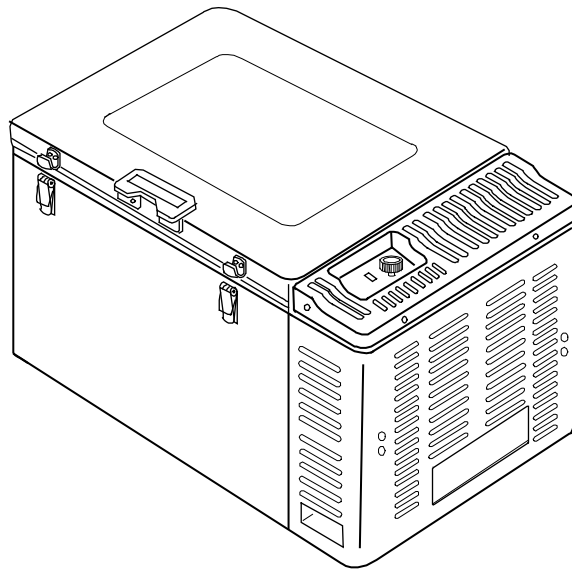

THE TABLE OF CONTENTS

1. SPECIFICATIONS	1
2. UNIT BLOCK DIAGRAM	2
3. WIRING DIAGRAM	2
4. INSTALLATION	3
4-1 INSTALLATION AND VENTING	
4-2 WIRE GAUGE IS IMPORTANT	
5. TROUBLE SHOOTING	4~5
5-1 BLOCK DIAGRAM	
5-2 TYPICAL TROUBLE	
5-3 TECHNICAL DATA	
6. CHECKING POINTS & MEASURING	6
6-1 Compressor input voltage	
6-2 Compressor coil resistance	
6-3 Thermistor resistance	
7. WORKING ORDER FOR REPLACEMENT	7~8
7-1 Cooling Unit	
7-2 Power Supply	

1. SPECIFICATIONS

F SERIES MODEL		MT60F-U1
STORAGE VOLUME	ℓ (liter)	60
EXTERIOR DIMENSIONS W × D × H	in	31.1 × 19.3 × 17.2 (Max. 31.6 × 20.5 × 17.4)
	mm	790 × 490 × 436 (Max. 801.5 × 520 × 441)
INTERIOR DIMENSIONS W × D × H	in	20.4 × 14.9 × 12.4
	mm	517 × 378 × 315
EXTERIOR FINISH	DOOR	Melamine coating steel plate
	CABINET	
INTERIOR FINISH	DOOR	A.B.S. Resin
	CABINET	
INPUT VOLTAGE	AC	AC85~132V 50/60Hz
	DC	DC 11V~32V
RATED AMPERAGE	AC	1.2A/AC120V
	DC	4.2A (Input voltage DC 12.8 V, Ambient temperature 30°C)
COMPRESSOR RATING		AC 16 V, 3A 48W
REFRIGERANT		Dichlorodifluoromethane (R-134a)
AVERAGE INSIDE ROOM TEMPERATURE (at Ambient temperature 30°C)		7°C ± 3°C by Thermostat control NOTCH 1
TEMPERATURE CONTROL NOTCH 5 OR FREEZE (at Ambient temperature 30°C)		Under -18 °C
TEMPERATURE CONTROL		Electronic thermostat
WEIGHT	LBS.	71
	Kg	32

2. BLOCK DIAGRAM

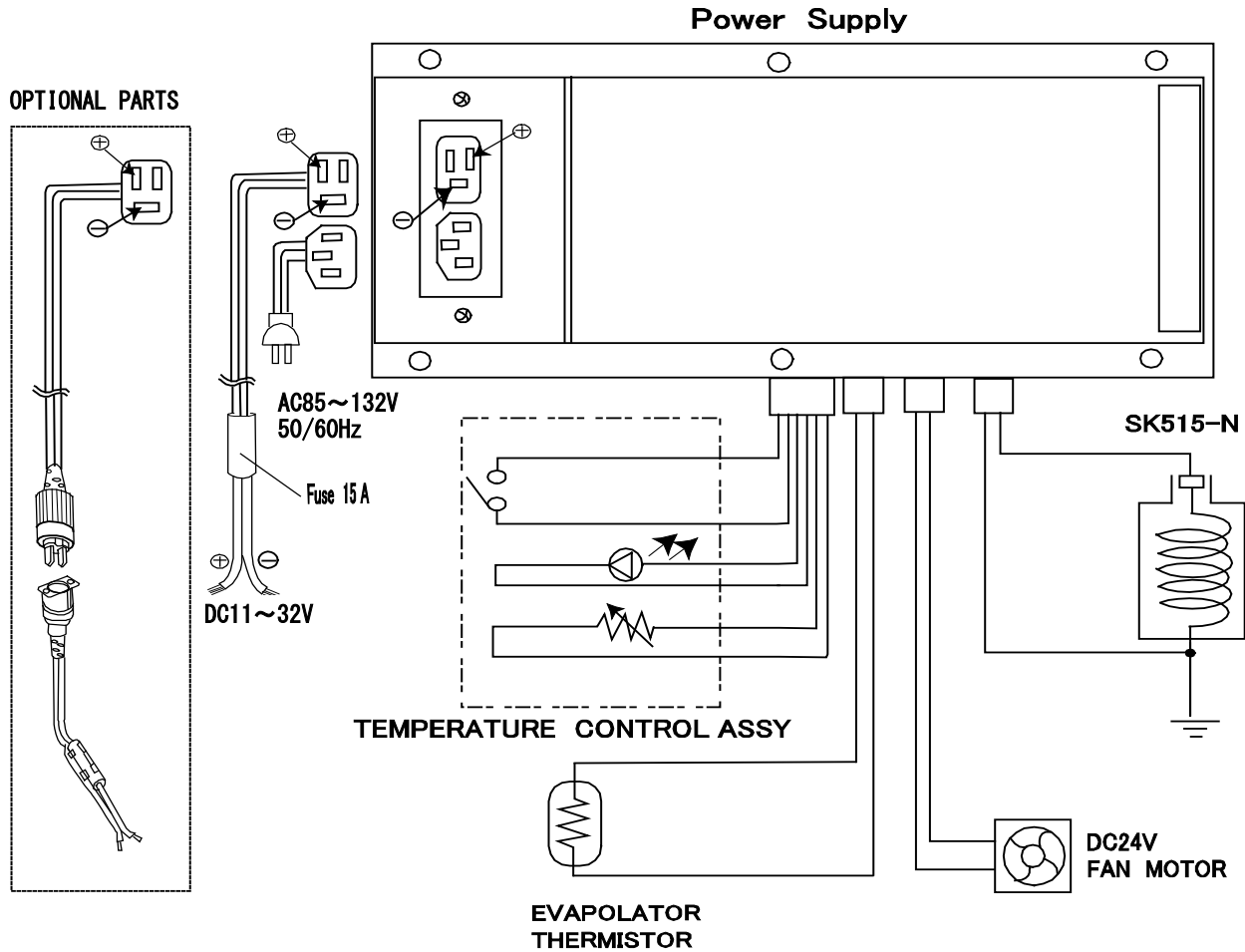

3. WIRING DAIGRAM

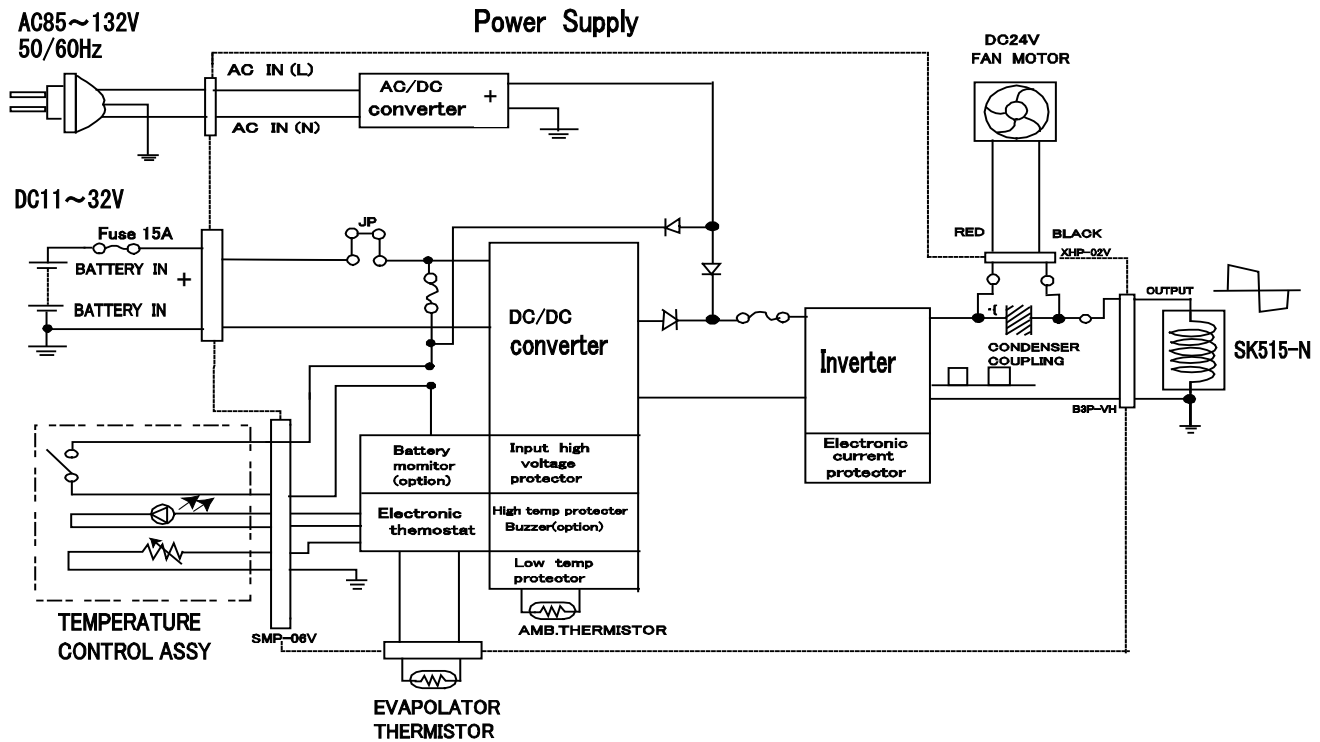

4. INSTALLATION

4-1 INSTALLATION AND VENTILATION

- (1) Your shockproof fridge should be installed on a solid surface board or floor.
- (2) Be sure your fridge is not put in direct sunshine, near a gas stove, heater or other heat-generating appliances.
- (3) Adequate ventilation and suitable distance from each wall (at least 150mm or more) result in maximum cooling performance and minimum electric current consumption for "free standing use" (refer to the fig. as below).
- (4) Avoid installing your fridge close to a kitchen sink and faucet.
- (5) If you would like to use the fridge under the counter or in the fixing box, please make sure the following air ventilating condition.
 - ① Make the openings for ventilation at top and bottom cover both side.
 - ② Opening size must be larger than 160cm² for each opening (additional air circulation above the condenser is expected better cooling performance).

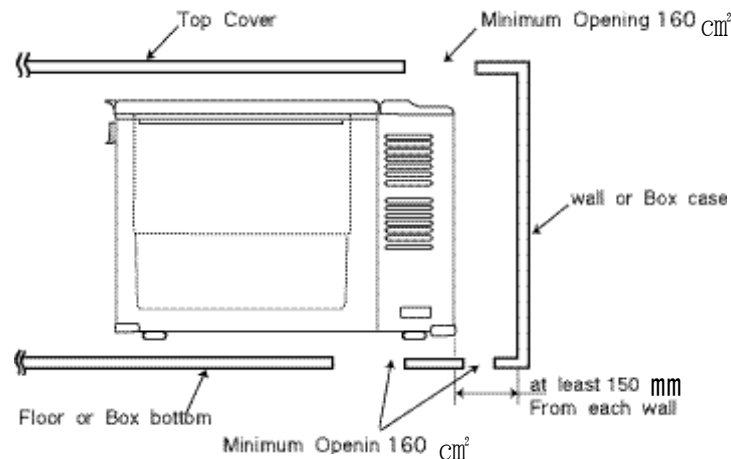

[CAUTION]

Insufficient ventilation results in poor cooling performance, compressor continuous operating, to be accelerated battery discharge and sometimes to be shortened the fridge life.

4-2 WIRE GAUGE IS IMPORTANT !

Please use following wire for the connection from refrigerator to battery.

Distance Between Fridge and battery	Wire gauge
	DC 12 volt series
Shorter than 3.7 m (12 ft.)	SWG # 18 (AWG # 16) / 1.2mm ²
From 3.7 m (12 ft.) to 6.1 m (20 ft.)	SWG # 16 (AWG # 14) / 2.1mm ²
From 6.1 m (20 ft.) to 9.6 m (31.5 ft.)	SWG # 14 / 3.2 mm ² (AWG # 12 / 3.3 mm ²)

5. TROUBLE SHOOTING
5-1 BLOCK DIAGRAM

Check

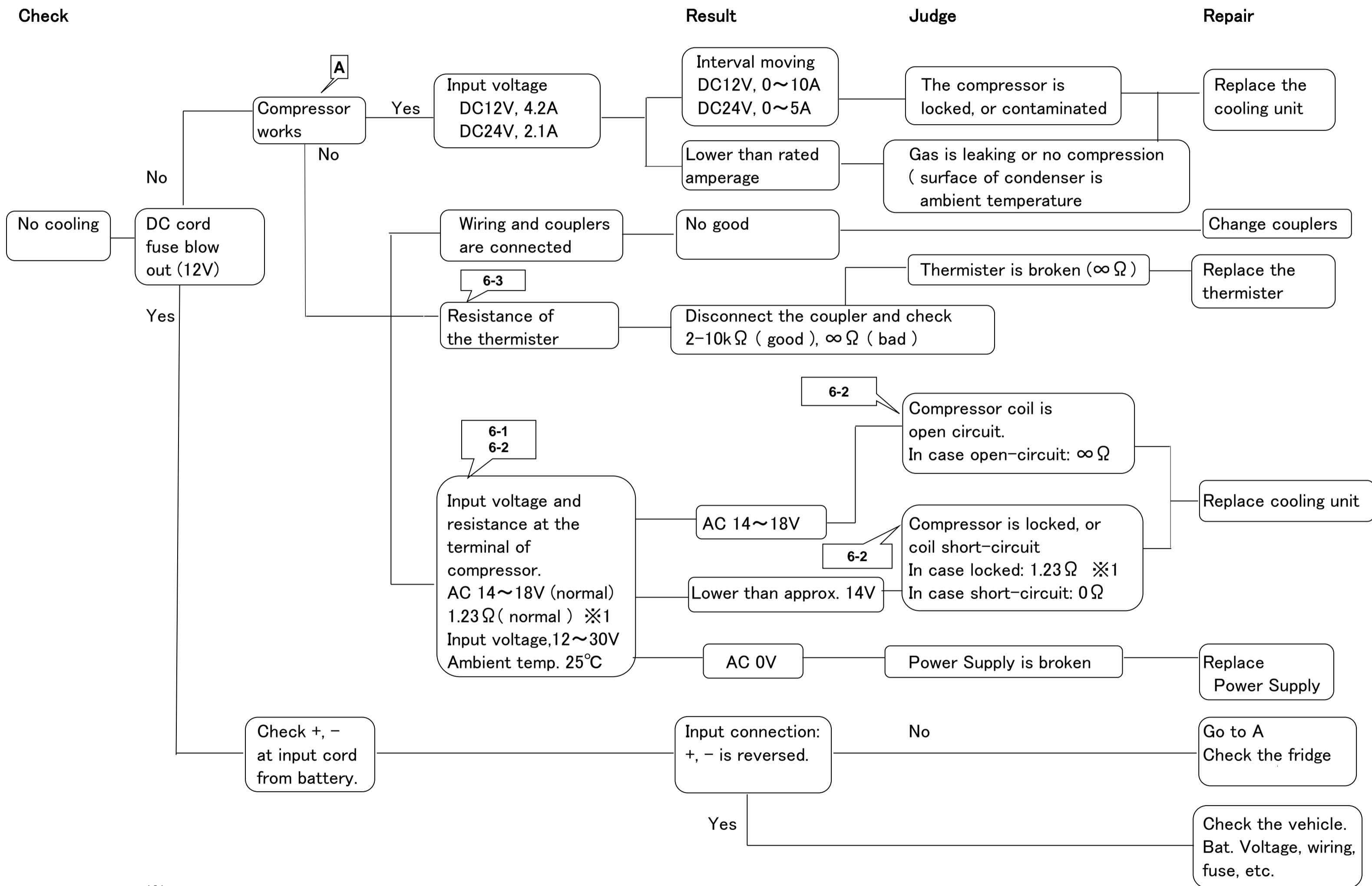

※1 This data come from Laboratory standard measurement.

5-2 TYPICAL TROUBLE

Condition		Source	Measuring Result	Operations
Control indicating lamp is lighting	No cooling Compressor does not operate.	Compressor coil is open circuit	Compressor coil resistance is $\infty \Omega$ (Normal: 1.23Ω ※1)	Replace the cooling unit
		Power Supply brake down	Power Supply output voltage is AC 0V (Normal: AC14~18V)	Replace the Power Supply
		Wire thermistor is open circuit	Thermistor resistance is $\infty \Omega$ (Normal: $2k \Omega \sim 10k \Omega$)	Replace the thermistor
	Cooling performance is not enough.	* Cooling Unit gas leak		Replace the cooling unit
		* Fan motor brake down		Replace the fan motor
		* Input voltage is lower than DC 10V		Charge the battery
		* Ambient temperature is higher than 30°C		
* Ventilation for compressor and condenser is not enough			At least make clearance 100 mm between fridge and wall	
	* To be stored too much in the fridge		Make good circulation of cold air	
Control indicating lamp is not light		* The special fuse of the DC cord blow out		Replace the fuse
		* Fuse of the vehicle blow out		Replace the fuse
		* DC power line of the vehicle is not good		Check the vehicle

5

5-3 TECHNICAL DATA

※1 This data come from Laboratory standard measurement.

Checking items	Measuring Points	Normal data
Compressor input voltage	At the terminals of the compressor	Approx. AC 14V ~ 18V
Power Supply output voltage	At the output cords from the Power Supply (Unfasten the output cords to the compressor)	Approx. AC 13V ~ 18V
Compressor coil resistance	Between compressor terminals (Unfasten output cords from compressor)	Approx. 1.23Ω ※1
Thermistor resistance	Between 2 pins of the thermistor connector	Approx. $2K \Omega \sim 10K \Omega$
DC cord Fuse resistance	Both side of Fuse	Normal: 0Ω

6. CHECKING POINTS & MEASURING

6-1 Compressor input voltage (Fig. 1)

- Measure at 2 poles coupler of Power Supply or at the input terminals of the compressor.

(Keep to connect the compressor when you measure it.)

Readings	Judgment
Approx. AC14~18V	Normal
AC 0 V	Power Supply is broken
Approx. AC14V or lower and interval moving	Compressor is locked

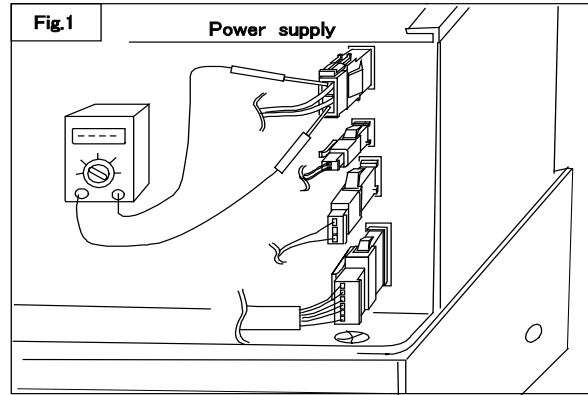

6-2 Compressor coil resistance (Fig.2)

Unfasten 2 poles coupler to the compressor and measure.

Readings	Judgment
Approx. 1.23 Ω ※1	Normal
∞ Ω	Broken (open circuit)
0 Ω	Broken (short circuit)

※1 This data come from Laboratory standard measurement.

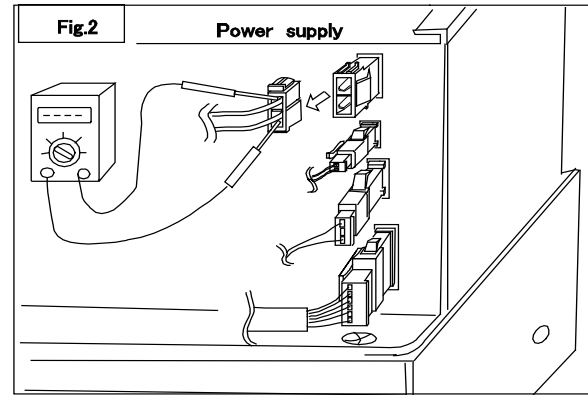

6-3 Thermistor resistance (Fig.3)

Unfasten the 3 poles coupler at the Power Supply and meature

Readings	Judgment
Approx. 2 kΩ ~ 10 kΩ	Normal
∞ Ω	Broken (open circuit)
0 Ω	Broken (short circuit)

Note) Compressor runs continuously when you make to short circuit at this coupler.

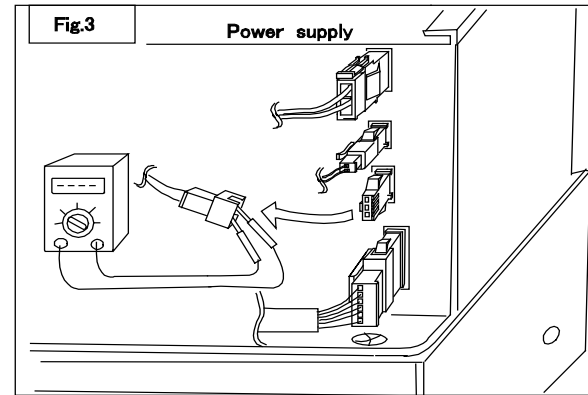

7. WORKING ORDER FOR REPLACEMENT

7-1 Cooling Unit

1. Remove Motor Cover (Fig.1)

Remove 4 screws which hold Motor Cover.

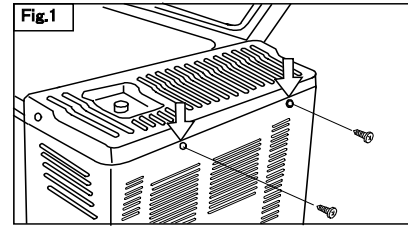

2. Remove 3 screws at Evaporator (Fig.2)

Take out the basket first,

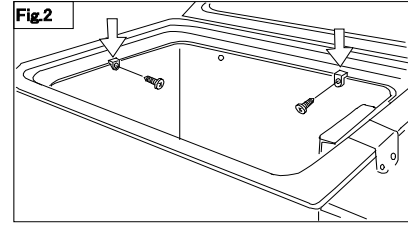

3. Take out Cover Pipe (Fig.3)

- ① Take off the cover.
- ② Remove 4 screws.
- ③ Pull out cover pipe.
- ④ Detach the rubber holders.

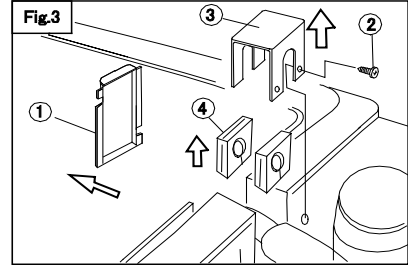

4. Remove 2 screws at the hanger of the compressor. (Fig. 4-①)

5. Remove 2 screws at condenser. (Fig.4-②)

6. Remove the earth screw. (Fig.4-③)

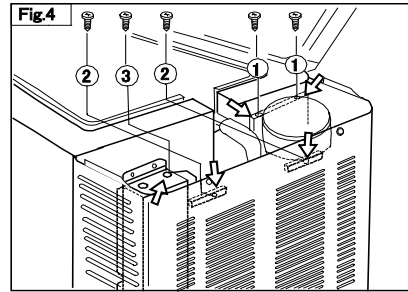

7. Take out Cooling Unit. (Fig.5)

- ① Take out Cooling Unit from the cabinet.
- ② Remove the screw which holds thermistor.

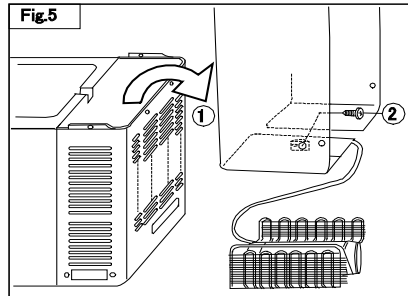

8. Take off the input cord from the compressor. (Fig.6)

- ① Take off the live side.
- ② Take off the earth side.

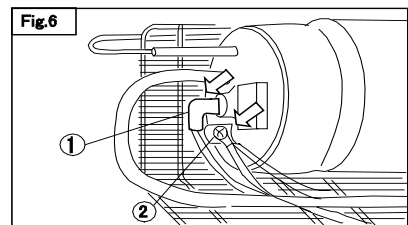

7-2 Power Supply

1. Remove the screws at Power Supply. (Fig.7)

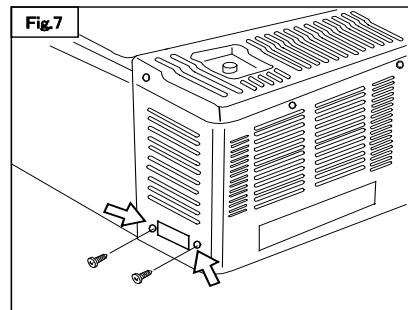

2. Remove Motor Cover. (Fig.8)

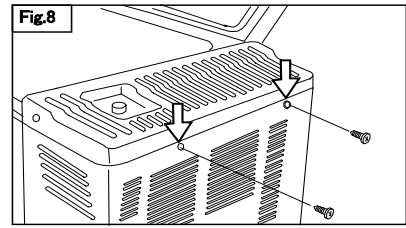

3. Pull out all the couplers at Power Supply (Fig.9)

- ① Motor input coupler
- ② Fan motor coupler
- ③ Thermister coupler
- ④ Control assy coupler

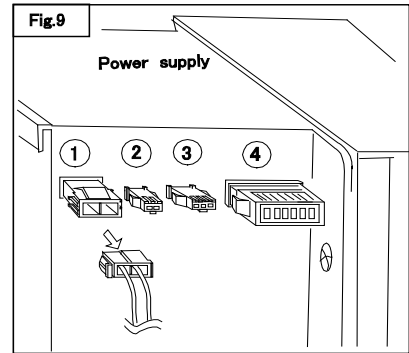

4. Remove the screws at Power Supply (Fig.10)

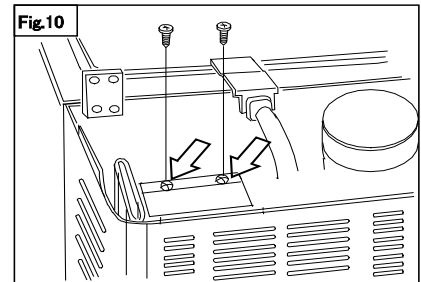

5. Pull out Power Supply towards the top (Fig.11)

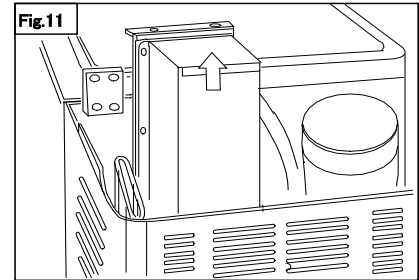

6. Remove Power Supply from cover (Fig.12—①)

7. Remove earth connection (Fig.12—②)

