

MT45F-U1CD-P

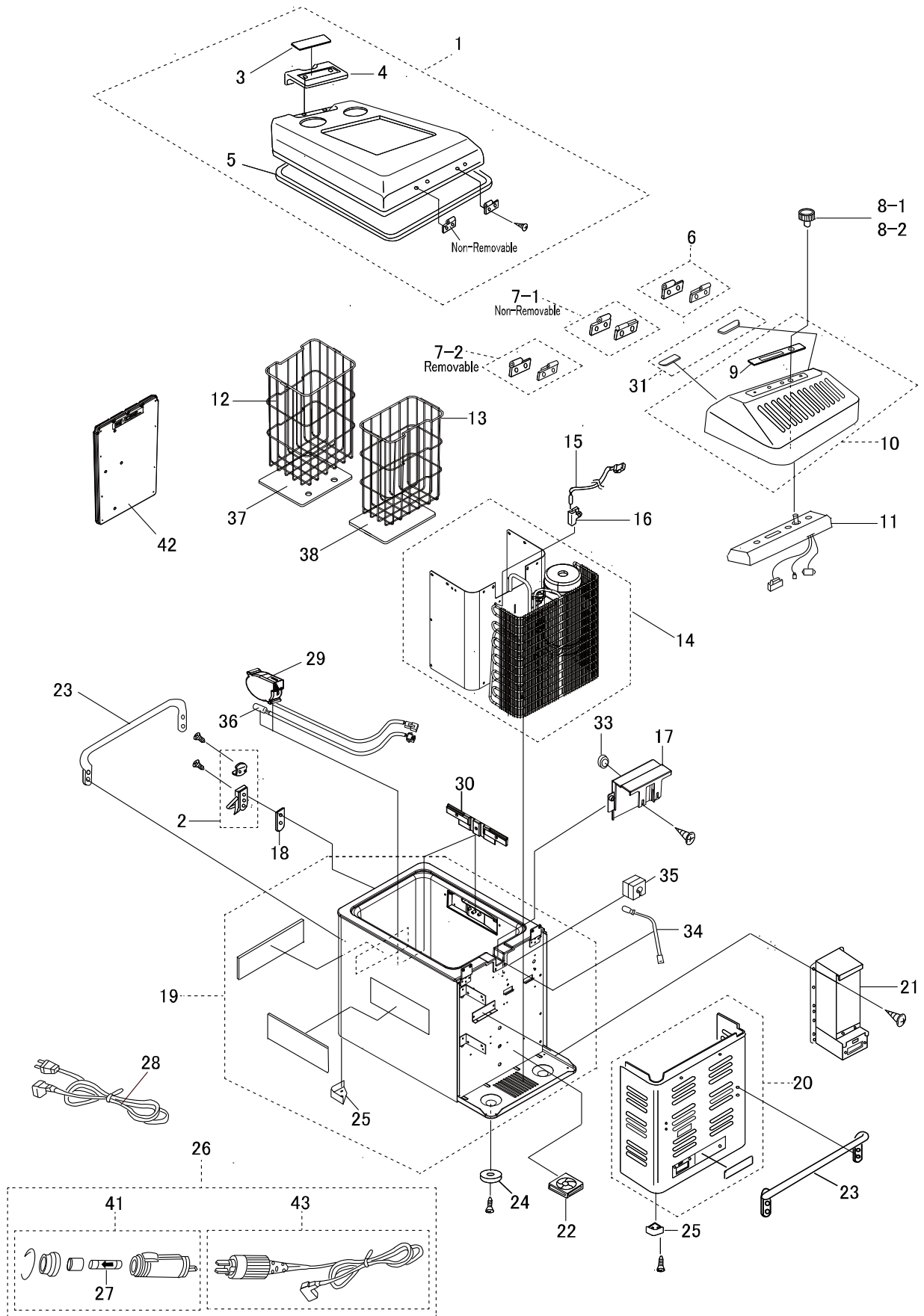

QTY SECTION	MODEL	MODEL CODE	PRODUCTION PERIOD	UNIT TYPE	REMARKS
A	MT45F-U1CD-P	0642 042 1R00	2017.12~	K3	

ITEM NO.	DESCRIPTION	ITEM CODE	QTY		QTY included per item code	REMARKS
			Used per fridge			
			A			
1	DOOR ASSY (non-removable) FINE GOLD	1600 448 70X9	1		1	
2	LATCH ASSY	1609 356 10X9	1		1	
3	MARK	5450 821 00X9	1		5	
4	DOOR HANDLE	4225 004 01X9	1		1	
5	GASKET	4148 039 01X9	1		1	
6	HINGE ASSY with LONG PIN	1609 345 30X9	1		1	
7-1	HINGE ASSY with LONG PIN	1609 345 40X9	1		1	for non-removable door
7-2	HINGE ASSY with SHORT PIN	1609 345 50X9	opt		1	for removable door
8-1	DIAL KNOB (standard)	1602 067 00X8	1		5	
8-2	DIAL KNOB (with white indicator line)	1602 067 10X9	opt		5	
9	MARK	5450 822 90X9	1		5	
10	COVER ASSY (Fine Gold)	1602 280 50X9	1		1	Include No.9
11	TEMPERATURE CONTROLLER	1601 215 12X9	1		1	Include No.9
12	BASKET A (Large)	5230 057 00X9	1		1	
13	BASKET B (Small)	5230 058 00X9	1		1	
14	COOLING UNIT (K3)	1610 148 00X9	1		1	
15	EVAPORATOR THERMISTOR	6055 081 10X9	1		1	Order and replace the thermistor and holder as a set.
16	HOLDER	4223 050 20X9	1		1	
17	COVER PIPE	4330 039 20X9	1		1	
18	"I" PLATE	4301 130 00X9	1		5	
19	CABINET ASSY (Fine Gold)	1600 447 71X9	1		1	
20	CASE COVER ASSY (Fine Gold)	1609 347 40X9	1		1	
21	POWER SUPPLY (K3)	1601 168 12X9	1		1	
22	FAN MOTOR ASSY (Cooling Fan)	1609 289 10X9	1		1	
23	HANDLE (Fine Gold)	3233 010 40X9	1 set		2	1set= HANDLE 2 Pieces
24	CUSHION	4120 139 00X9	1 set		4	1set= CUSHION 4 Pieces
25	CORNER CUSHION	4274 009 30X9	1 set		4	1set= CORNER CUSHION 4 Pieces
26	DC CORD ASSY	1912 404 00X9	1		1	
27	SPECIAL THERMAL FUSE	1603 002 00X9	1		1	
28	AC CORD ASSY	1912 417 00X0	1		1	
29	FAN MOTOR (Blower Fan)	6080 031 01X9	1		1	
30	HOLDER	4223 088 00X9	2		1	
31	CUSHION (Rx1 & Lx1 as 1 set)	4120 191 00X9	1 set		5 sets	4120 191 00X9= 5sets(Rx5 & Lx5)
33	CAP	4101 167 00X9	1		1	
34	DIODE ASSY	1609 484 00X9	1		1	
35	BUSHING	4160 063 10X9	1		1	
36	INTERNAL FAN THERMISTOR	6055 081 60X9	1		1	
37	MAT (Large)	4303 048 40X9	1		1	
38	MAT (Small)	4303 048 30X9	1		1	
41	PLUG ASSEMBLY	1602 121 00X9	1		1	
42	DIVIDER	1602 284 00X9	1		1	
43	DC CORDC without PLUG ASSEMBLY	1912 401 00X9	1		1	