

MD14F-U

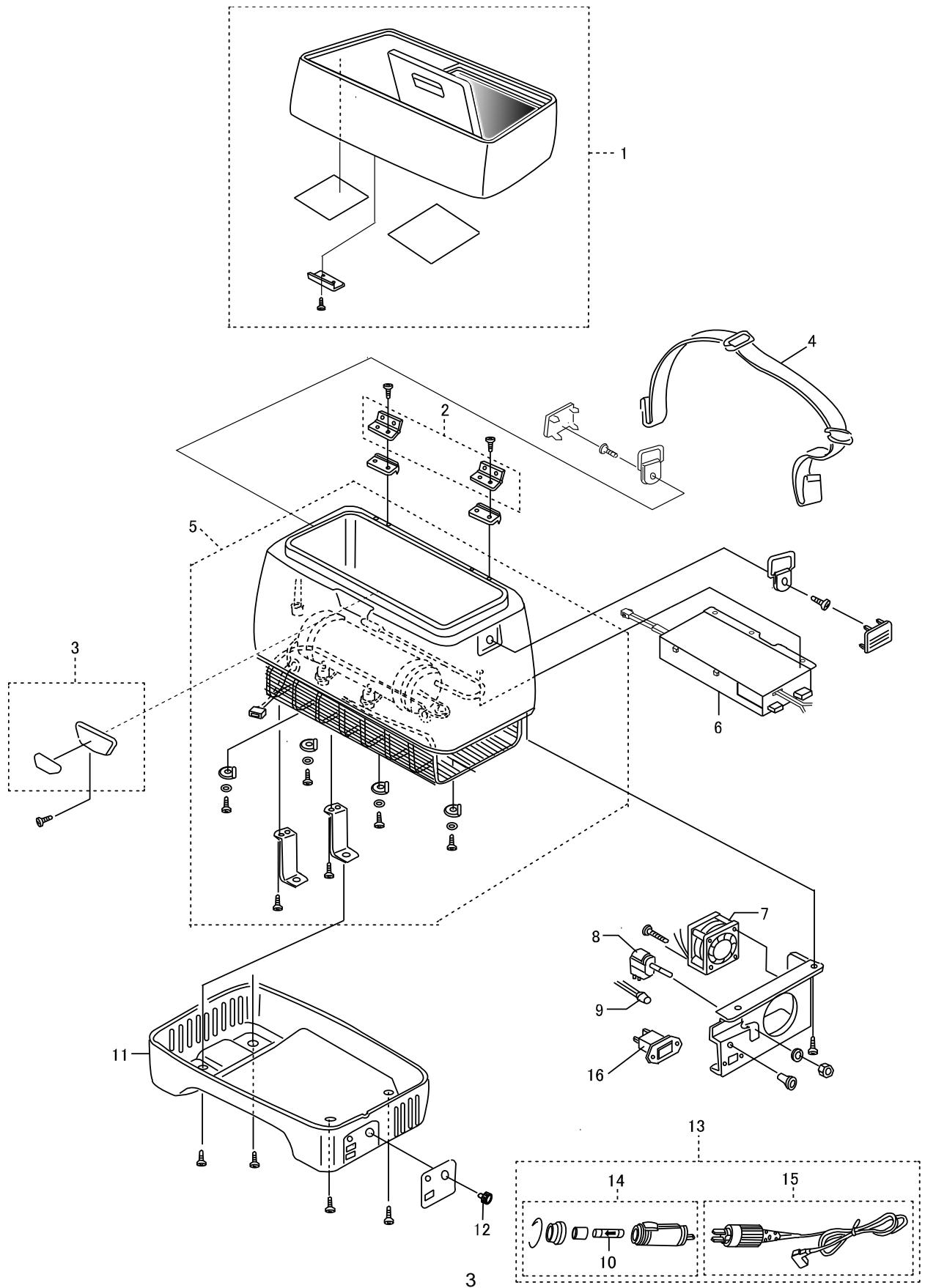

QTY SECTION	MODEL	MODEL CODE	PRODUCTION PERIOD	UNIT MODEL	REMARKS
A	MD14F-U	0642 013 3040	2018.12~	N21	FCM (Food Contact Materials)

ITEM NO.	ITEM	ITEM CODE	QTY				QTY included per item code	REMARKS
			Used per fridge					
			A	B	C	D		
1	DOOR ASSY	1600 325 20X9	-				1	FCM (Food Contact Materials)
2	HINGE	1609 266 00X9	1set				2	1set= HINGE 2Pieces
3	LATCH ASSY	1602 099 40X9	1				1	
4	SHOULDER STRAP	4101 121 00X9	1				1	
5	COOLING SYSTEM	1600 598 10X9	1				1	FCM (Food Contact Materials)
6	POWER SUPPLY	1601 210 00X9	1				1	
7	FAN MOTOR	1609 289 20X9	1				1	
8	REGISTOR VARIABLE	1609 502 00X9	1				1	
9	DIODE ASSY	1609 154 20X9	1				1	
10	FUSE ASSY	1603 002 00X9	1				1	
11	CASE BOTTOM	4332 052 50X9	1				1	
12	DIAL ASSY	1602 067 00X8	1				5	
13	DC CORD	1912 404 50X9	1				1	
14	PLUG ASSY	1602 121 00X9	1				1	
15	DC CORD (Without No. 14)	1912 401 00X9	1				1	
16	TERMINAL BLOCK	1602 041 00X9	1				1	