

MB40V / MB40V-H

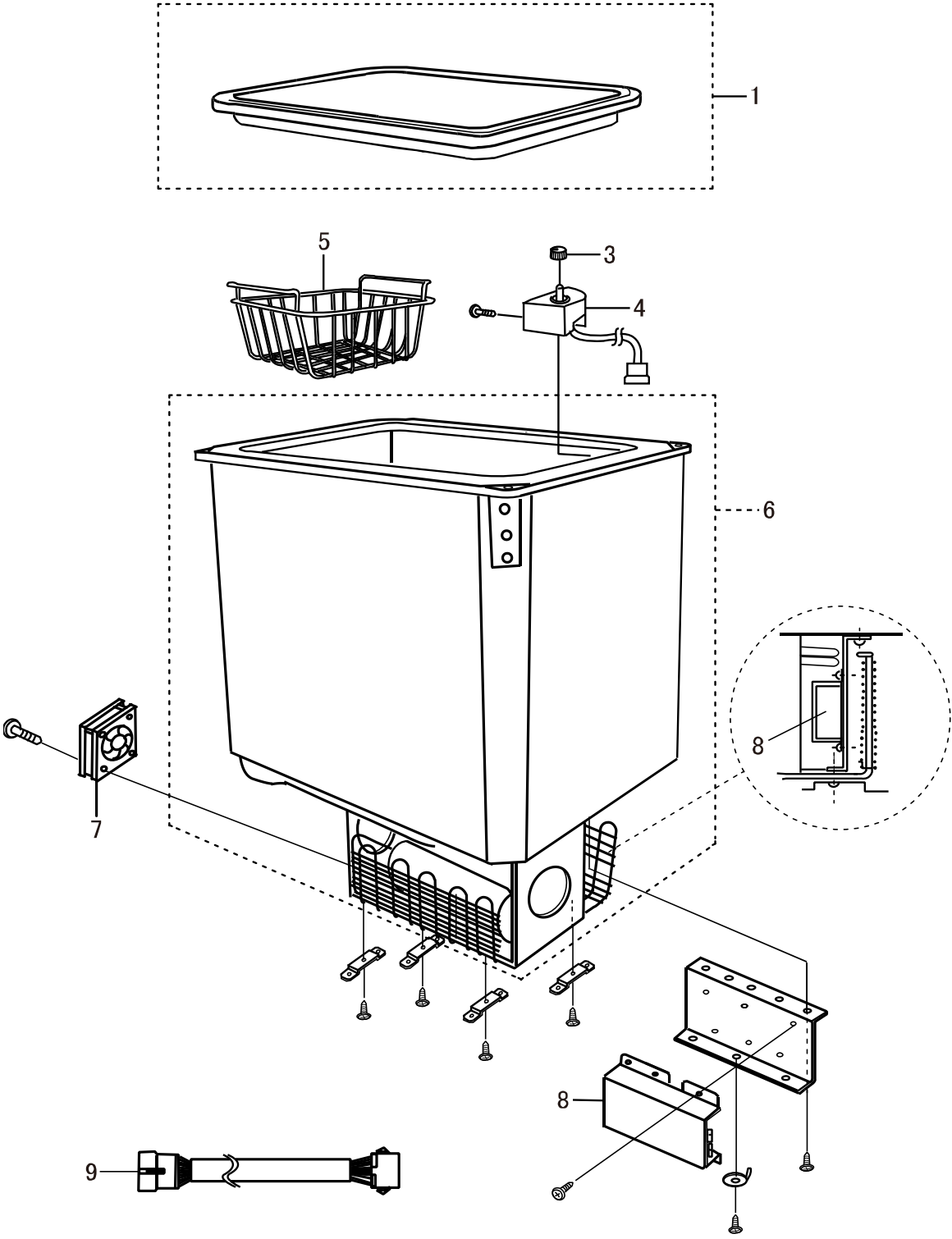

QTY SECTION	MODEL	MODEL CODE	PRODUCTION PERIOD	UNIT MODEL	REMARKS
A	MB40V	0642 040 2240	2012.01~2021.11	N21	
B	MB40V-H	0642 040 2250	2012.01~2021.11	N21	

ITEM NO.	DESCRIPTION	ITEM CODE	QTY				QTY included per item code	REMARKS
			Used per fridge					
			A	B	C	D		
1	DOOR ASSY	1600 603 01X9	1	1			1	FCM (Food Contact Materials)
3	DIAL ASSY	1602 067 00X8	1	1			5	
4	CONTROL ASSY	1601 212 10X9	1	1			1	
5	BASKET	5230 056 00X9	1	1			1	
6	COOLING UNIT	※1	1	1			-	FCM (Food Contact Materials)
7	FAN MOTOR	1609 289 30X9	1	1			1	
8	POWER SUPPLY	1601 210 20X9	1	1			1	
9	COUPLER ASSY	6010 784 00X9	1	-			1	Accessories

2021.02#0

※1 It becomes product exchange when a cooling system breaks down.

The component parts of a cooling system are a cooling unit, a thermo sensitive register, and a cabinet.