



# Installation instructions for NOVELLIS LED Oyster

Model No	19986/05
[W]	35W

Before first using your new Brilliant LED Oyster it is most important that you read and follow these instructions, even if you feel you are quite familiar with this type of product. Retain this document for future reference.

**THIS FIXTURE MUST BE INSTALLED BY A QUALIFIED ELECTRICIAN**



## Specifications:

- Fitting : Fixed LED luminaire with Aluminium body and PC diffuser.
- Rated Supply Voltage: 240V AC, 50Hz.
- Maintained LED Power: 35W.
- Photometrics: 2200lm, 5000K.
- Battery Type: Li-Ion 3.7VDC 3600mAh
- Recharge Hours: 16 hours.
- Classification: D40.
- Lamp type: LED.
- Protection Class : Class I.
- Ingress Protection: IP20 (For indoor use only).
- Fixing: Surface mounted. Intended to be used while fastened to a support.
- Dimming: Non Dimmable.
- Ambient Temperature Ta: 10-40°C

## For Your Safety, please read this instruction manual carefully before installation:

- Installation, repair and/or inspection must be conducted by qualified personnel in accordance with Australian Standards and local Building codes.
- Do not install in a position where the fixture can be easily accessed by children or infirm persons.
- Do not perform modification to the fixture.
- Do not touch the fixture when switched on.
- This fixture is not dimmable.
- Red LED indicates charging state of battery: LED on indicates Charge; LED off indicates loss of a.c. power.
- Inspection and maintenance must be performed in accordance with AS/NZS2293-2.
- The battery must be replaced when the unit no longer meets rated operating life.
- Ensure battery is kept as far as possible from lamp and heat sources when installed.
- Failure to follow these instructions will void the warranty.

## Environmental Protection:

This electrical product should not be disposed as normal waste. Please always recycle!  
Check with your Local Council about your recycle options.



Model No	19986/05
[W]	35W

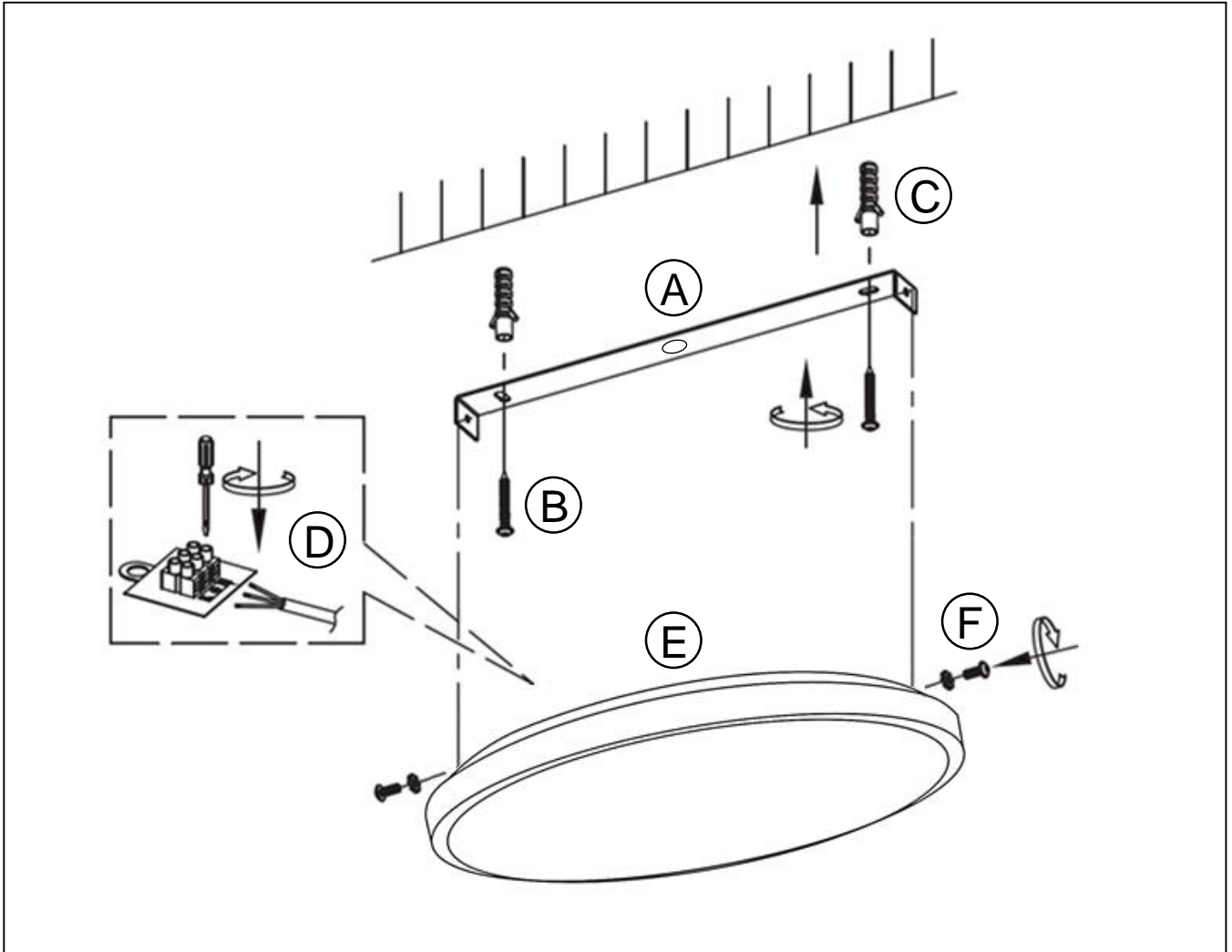

## Installation Instructions:

1. Ensure mains supply is switched OFF.
2. Unpack the fixture and accessories carefully and place on a flat surface. Dispose all packaging material thoughtfully.
3. Drill mounting holes and cable entry hole into the mounting surface using bracket (A) as a template.
4. Secure bracket (A) to the mounting surface using screws (B). Rawl plugs (C) need to be used for concrete mounting surface.
5. Run mains wire through the cable entry hole and connect the Live (L), Switched Live (SL), Neutral (N) and Earth according to the markings on the terminal block. Make sure the connections are firm and secure.
6. Secure the fitting (E) to the bracket (A) using screws (F).
7. Turn the power on. The Status LED will light up indicating control gear is on.
8. When the power is disconnected the Emergency LED will light up and be powered by the battery.
9. Pressing the test switch will simulate a power outage.
10. Allow a minimum of 16 hours charge time for initial charge.



## Installation instructions for NOVELLIS LED Oyster

Model No	19986/05
[W]	35W

### Warranty:

Brilliant Lighting warrants this product against defects in manufacture and workmanship for a period of 3 years from date of purchase or as specified on the packaging. For products used in non-domestic or commercial applications, Brilliant Lighting warrants this product for a period of 3 months from date of purchase. This warranty is only valid for products installed and operated within the guidelines specified by Brilliant Lighting, and within the correct operating voltage ranges as stated on the product's rating label.

Warranty does not include damage or loss arising from incorrect installation, operation or maintenance of this product, damage caused through modification, incorrect installation, service by unqualified or unauthorised personnel or lack of regular maintenance and cleaning. Proof of installation by qualified personnel may be required, e.g. Electrical Safety Certificate. Proof of purchase must be supplied with all warranty claims.

This warranty is provided in addition to any other rights and remedies of the customer under any law. In applications not intended for household, personal or domestic use, liability is limited to replacement or reimbursement of product only. Brilliant Lighting does not warranty the costs of removal or re-installation of this product or associated components.

*Our goods come with guarantees that cannot be excluded under the Australian Consumer Law. You are entitled to a replacement or refund for a major failure and compensation for any other reasonably foreseeable loss or damage. You are also entitled to have the goods repaired or replaced if goods fail to be of acceptable quality and the failure does not amount to a major failure.*

Any claim under this warranty must be made within the specified warranty period from date of purchase of this product. To make a claim under the warranty; at your own expense take the product (with proof of purchase – receipt or similar) to the store where you purchased the product or contact Brilliant Lighting at the address below

This warranty is given by:

**Brilliant Lighting (Aust) Pty. Ltd.**  
**ABN 37 006 203 694**  
**956 Stud Road Rowville, VIC 3178**  
**Phone: 03 9765 2555**  
**Email: [info@brilliantlighting.com.au](mailto:info@brilliantlighting.com.au)**  
**[www.brilliantlighting.com.au](http://www.brilliantlighting.com.au)**