



Installation Manual

CRUZE ABS CEILING FAN

With and without LED Light



20530 – 52" Blades



20532 – 52" Blades with LED Light

YOUR BRILLIANT CEILING FAN

Congratulations on the purchase of your new quality Brilliant Ceiling Fan. Before installation, it is most important that you read and follow the instructions in this use and care booklet, even if you feel you are quite familiar with this type of product.

Find a safe place and keep this booklet handy for future reference.

THIS IS NOT A DIY PRODUCT.

THIS PRODUCT MUST BE INSTALLED BY A QUALIFIED ELECTRICIAN



IMPORTANT SAFEGUARDS:

Read all instructions carefully, even if you feel you are quite familiar with this type of appliance.

When using electrical appliances, in order to reduce the risk of fire, electric shock, and/or injury, these basic safety precautions should always be followed:

1. This ceiling fan **MUST** be installed by a Qualified Electrical Contractor in accordance with the local regulations, and all local, state and national electrical codes. Any alterations or additions to building wiring must be completed by a licensed electrical mechanic, or person authorised by legislation to work on the fixed wiring of any electrical installation.
2. The ceiling fan must be connected to a 240V AC 50Hz power supply.
3. All electrical work must only be undertaken after disconnection of the power by removing fuses or turning off the circuit breaker, to ensure all pole isolation of the electrical supply.
4. The fan must be electrically Earthed.
5. The fan must be installed that the blades are **at least 2.1** metres above the floor.
6. The structure that the ceiling fan is connected to must be capable of supporting a weight of at least 45kg. The fixing must be able to support the moving weight of the fan and must not twist or work loose.
7. Make sure that the installation site will not allow the rotating fan blades to come into contact with any object and that there is a minimum clearance of 150mm (6") from the blade tip to the wall or ceiling. Please note that the bigger this clearance is the better the airflow from your fan will be.
8. **DO NOT** use outdoors unless covered. Refer to Warranty terms for Alfresco use.
9. **DO NOT** connect the fan motor to a dimmer switch. This may damage to the motor. Use **ONLY** the provided wall controller.
10. This appliance is not intended for use by young children or infirm persons without supervision.
11. Young children should be supervised to ensure that they **DO NOT** play with the appliance.
12. It is not recommended that ceiling fans and gas appliances be operated in the same room at the same time.
13. The fan must be turned off and stopped completely before reversing the fan direction. This will prevent any damage to the motor of the fan or controller (if installed).
14. Do not insert anything into the fan blades whilst they are spinning. This will damage the blades and upset the balance of the fan causing the unit to wobble.
15. After the fan is completely installed make sure that all base and fan blade fixings are secured and tightened to prevent any problems.
16. Because of the fan's natural movement, some connections may loosen. Check the support connections, brackets and blade attachments twice a year to make sure they remain secured. If any are loose, tighten.
17. A blade balancing kit is included. Ensure blades are balanced immediately after installation to reduce wobble and noise.
18. An all-pole disconnection incorporated in the fixed wiring is to be provided, such as an all-pole switch or a supply cord fitted with a plug.

IMPORTANT NOTE:

The important safeguards and instructions given in this manual are not meant to cover all possible conditions and situations that may occur. It must be understood that common sense, caution and care are factors which cannot be built into any product.

FAULT FINDER:

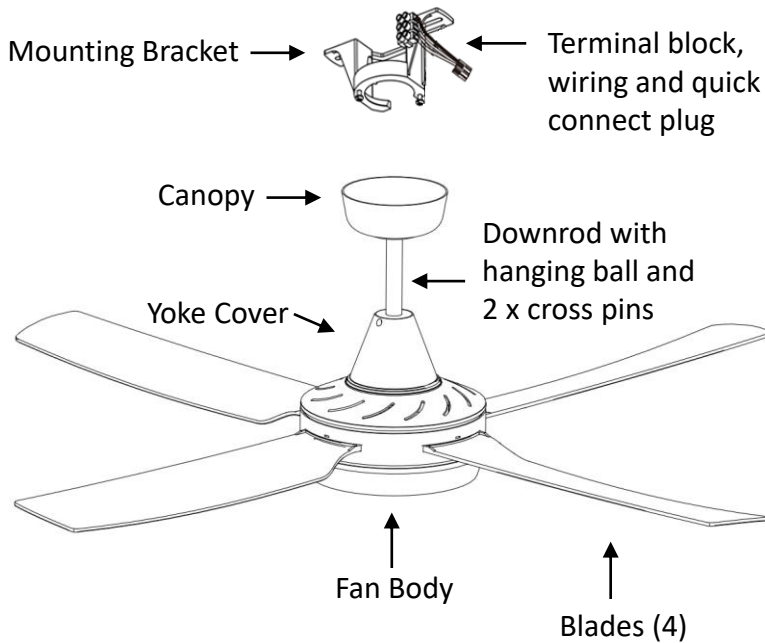

- Always check the "Trouble Shooting Checklist" included in this booklet before seeking warranty claim.
- Mechanical noise may be noticed on installation. Allow at least 8 hours settling-in period.
- Some fans may wobble more than others, even if they are identical. This does not necessarily indicate a fault.

INSPECT CONTENTS CAREFULLY TO BE CERTAIN ALL PARTS HAVE BEEN INCLUDED





Hardware Bag

For Mounting Plate:

- Flat Washer x2 
- Wood Screw x2 

For Blade Balance :

- Balancing Slide x 1 
- Weight block (3G x 3) 

Wall Controller

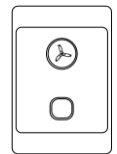

Hardware Bag

- Wood Screw x 2 

Selecting a Location

DO NOT use outdoors unless covered. Refer to Warranty terms for Alfresco use.

Choose a location for mounting the fan where the blades will have at least 2.1 metres of clearance from the floor. If the location you have chosen does not have a suitable support beam capable of supporting 45kg, install a brace at least 2" x 4" between the ceiling joists as a support medium.

Make sure that the installation site will not allow the rotating fan blades to come into contact with any object and that there is a minimum clearance of 150mm (6") from the blade tip to the wall.

Please note that the bigger this clearance is the better the airflow from your fan will be.

Before Installing

Unpack your ceiling fan carefully, then remove all parts and components, and lay on a cloth or soft surface to avoid damage. DO NOT lay the motor housing on its side, the housing may get damaged.

Before commencing installation, check that all parts are included. NB: You may need to remove all foam packaging material to ensure there are no missing components.

Mounting the bracket

Secure the mounting bracket to the ceiling joist or suitable structure that is capable of carrying a load of at least 45kg, Ensure that at least 30mm of the mounting screws are threaded into the Support.

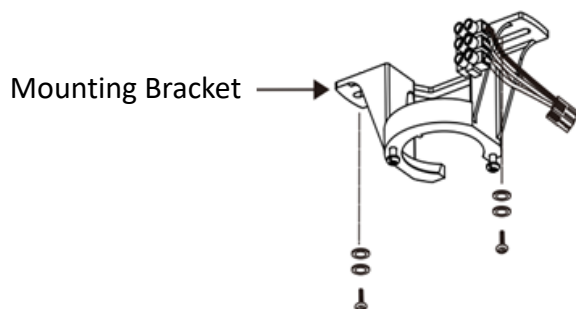



Assembling the blades

Push the Ezi-Fit blades into the slots to lock - No tools or screws needed for blade assembly.

Ensure blades are fully inserted – A positive click will be heard when blade locking tabs engage.

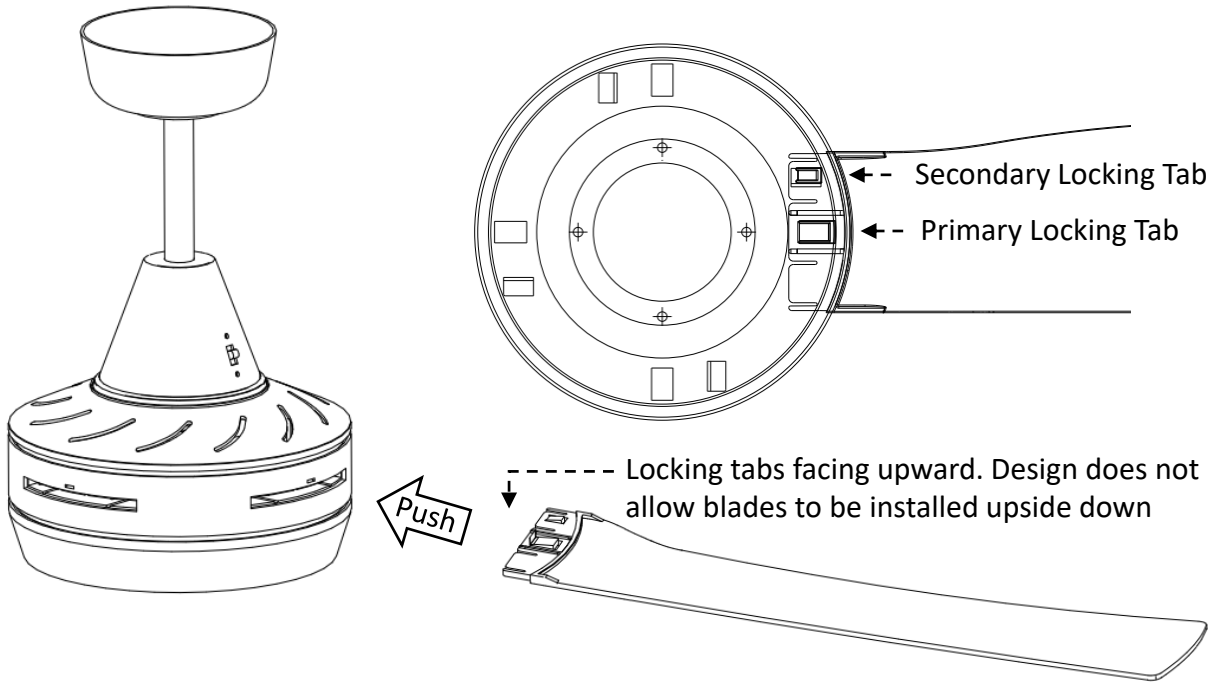

Removing the blades

Unscrew nut in a anti-clockwise direction and lift yoke cover up to reveal three top cover screws.

Remove screws and lift fan body top cover up to reveal blade locking tabs.

Push primary and secondary locking tabs down with a tool such as a screwdriver and remove blades.

CAUTION: MAKE SURE FAN IS DISCONNECTED FROM POWER BEFORE REMOVING BLADES

CAUTION: MORE THAN 1 PERSON MAY BE REQUIRED TO ASSIST IN REMOVING THE BLADES

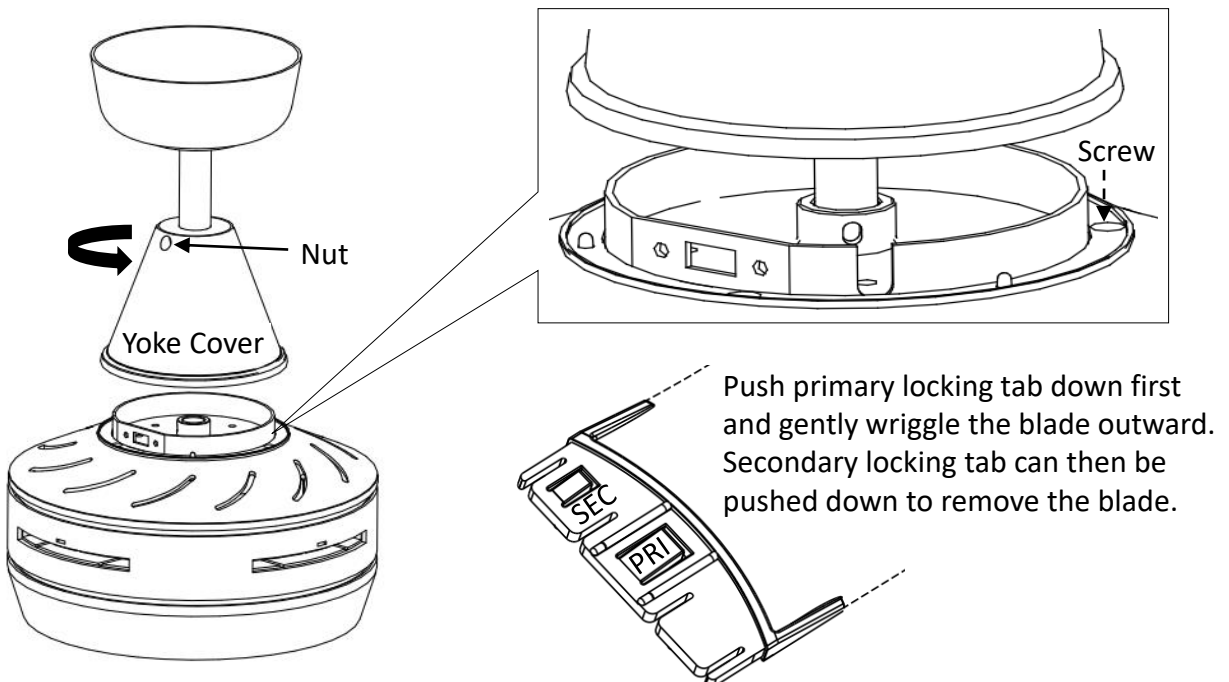



Mounting the fan

Carefully lift the fan, and place the down rod ball assembly into the mounting bracket. Slowly rotate the shaft until the ball correctly locks into place (ball groove aligns with bracket ridge).

Refer to the following section detailing 'Electrical Wiring' for details on how to wire this product correctly.

After the fan has been wired to the power supply, carefully position all excess cable inside the boundaries of the hanging bracket.

Slide the canopy along the downrod and over the mounting bracket taking care not to damage wires. Once in position secure canopy with screws provided.

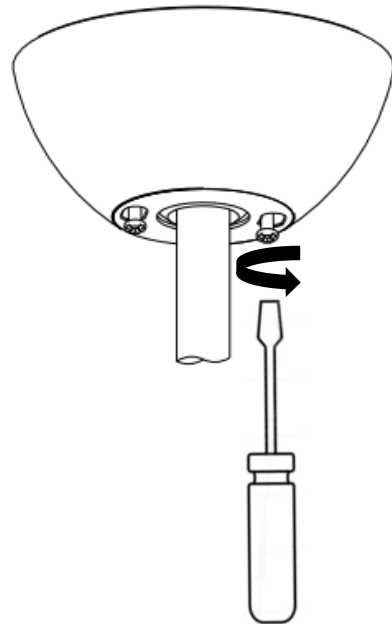
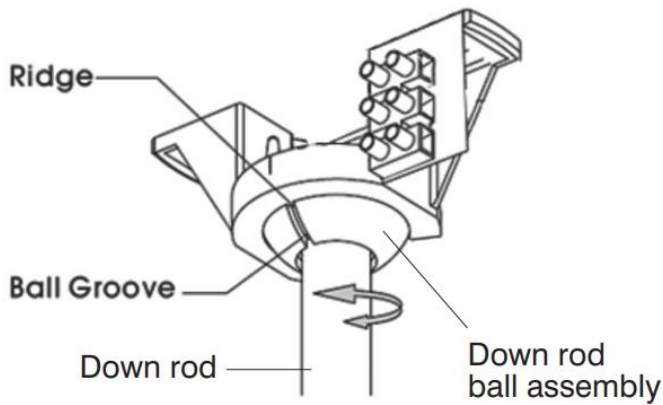



Electrical Wiring

This ceiling fan must be installed by a licensed/qualified electrician.

CAUTION: Before installing the fan, make sure you have turned OFF the electricity supply.

IMPORTANT: ENSURE ALL CABLES ARE ELECTRICALLY ISOLATED BEFORE WIRING.

Wire the incoming power cables to the terminal block mounted on the mounting plate. Wire Active, Neutral and Earth to the corresponding terminals respectively.

Check that there are no loose wire strands hanging out of the terminal block. Check that the cables are terminated into the correct position in the terminal block.

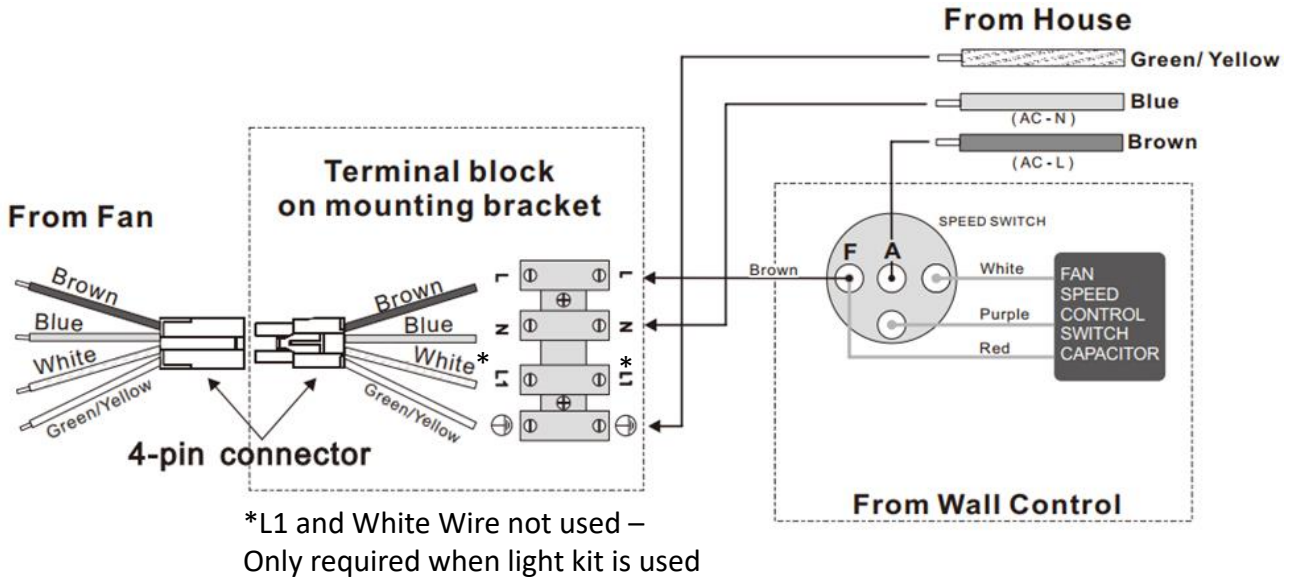

Reverse Switch

The “Summer / Winter” switch should be in left position to make the fan rotate in an anti-clockwise direction during summer. In winter, this switch should be in the right position so that the blades now move in a clockwise direction.

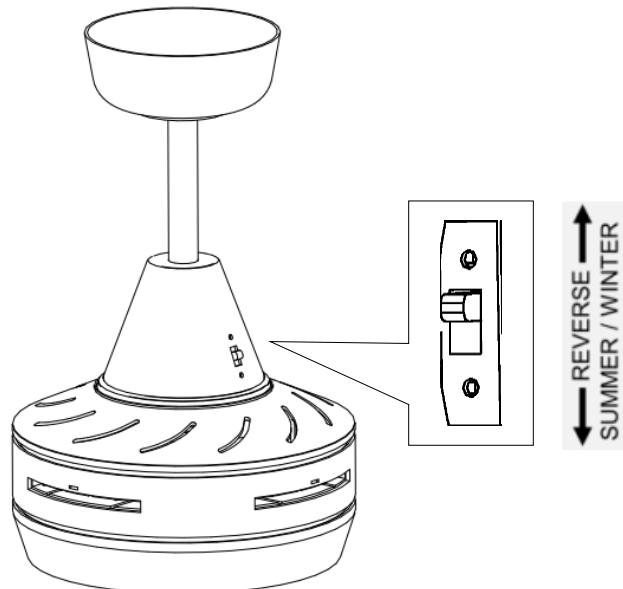
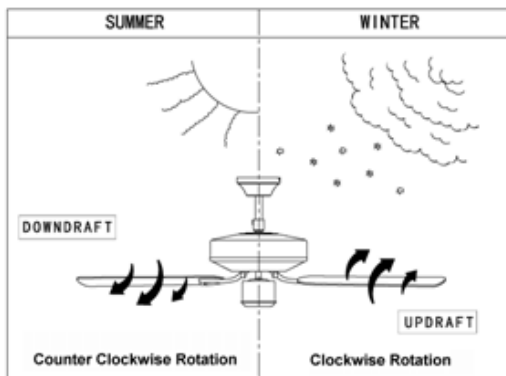



CARE & CLEANING:

Periodic cleaning of your ceiling fan is the only maintenance required.

Use a soft brush or lint free cloth to avoid scratching the finish. Please turn off electricity when you do so.

Do not use water when cleaning your ceiling fan. It could damage the motor and create the possibility of an electrical shock.

The motor has a permanently lubricated ball bearing and as such, is maintenance free.

NOISE:

The manufacturer warranty covers actual faults that may develop, but NOT minor complaints, e.g. motor operation noise - ALL ELECTRIC MOTORS ARE AUDIBLE TO SOME EXTENT; this is more obvious when the fan is operating at low speeds.

WOBBLE:

Ceiling fans are designed to move during operation because they are not generally rigidly mounted. Movement of a couple of centimetres is acceptable for safe operation.

Balancing kits included could be used to adjust the balancing.

NORMAL WEAR AND TEAR:

Threaded components working slightly loose or blade carriers even slightly bent due to vigorous cleaning or bumping can cause extra wobble and noise. THIS IS NOT COVERED UNDER WARRANTY but a little care and maintenance can reduce or prevent this problem.

BALANCING:

This fan includes a blade balancing kit. Upon initial installation, the balance kit should be used on the fan blades to reduce wobble.

The balance kit includes instructions on how to perform the balancing procedure.

Balancing the fan and reducing wobble will result in quieter operation and optimum performance.

Technical Data

MODEL	RATED VOLTAGE	MOTOR WATTAGE	IP RATING	MAX CEILING RAKE	Light Wattage	Dimmable	CCT Selectable	WEIGHT
20530	220-240VAC	50W	IP20	30 degrees	NA	NA	NA	5.3kgs
20532	220-240VAC	50W	IP20	30 degrees	18W	Yes*	Yes	5.6kgs

*Refer to recommended dimmers over page.



Troubleshooting

PROBLEM	PROBABLE CAUSE	SUGGESTED REMEDY
Fan will not start	1) Fuse blown or circuit breaker has tripped 2) Loose plug connections to the fan.	1) Check mains power and reset breaker or replace fuse. 2) Check plug connections to fan.
Fan wobbles	1) Blades not balanced 2) Loose blades.	1) Use balancing kit provided 2) Insert blades ensuring primary and secondary locking tabs are engaged.
Fans sounds noisy	1) Loose fan blades. 2) Loose mounting bracket	1) Insert blades ensuring primary and secondary locking tabs are engaged. 2) Tighten mounting bracket screws
Mechanical Noise	Fan not settled in	Allow at least 8 hours of use for the fan to settle in

LIGH KIT FEATURES (20532)

COLOUR CHANGING:

The Light kit incorporates a selectable colour changing temperature option.

To change the colour temperature turn the light (at the wall switch) on, then off and on again quickly (within 0.5 to 2 seconds). You can select Warm white (3000K), Cool white (4200K) or Daylight (6000K).

If switched off and on for longer than 3secs the colour temperature will remain the same.

Please note the light source contained in this luminaire shall only be replaced by the manufacturer or his service agent of a similar qualified person

DIMMING:

The below dimmers are recommended for dimming the Light kit.

For best performance, always turn your light on with the dimmer adjusted to maximum.

Brand	BRILLIANT	BRILLIANT	CLIPSAL	CLIPSAL	CLIPSAL	CLIPSAL
Model	18829/05	18828/05	4062E450UDM	32E450TM	32E450UDM	31E4RUD
Brand	CLIPSAL	DIGINET	HPM	HPM	HPM	LUMEX
Model	32ELEDM	MMDM/RT	EM400A2P	EM400A3P	EM250T	LOADSMART



Brilliant Fan Warranty

Please note, this warranty voids any other warranties supplied with this product and complies with the new consumer guarantee requirements.

WARRANTY:

The benefits conferred by this warranty are in addition to all implied warranties, other rights and remedies in respect of the product, which the consumer has under Australian Consumer Law.

The original purchaser of this Brilliant Ceiling Fan is provided with the following warranty subject to the Brilliant Warranty terms and conditions as found on the Brilliant website and the following conditions.

Brilliant Lighting (Aust) Pty Ltd warrants this ceiling fans motor for a period of 6 years from the date of purchase, the first 3 years are covered by an in-home warranty. All parts deemed defective in workmanship or materials will be replaced free of charge.

This warranty is in addition to any other rights and remedies of the customer under any law. In applications not intended for household, personal or domestic use, liability is limited to replacement or reimbursement of product only.

The warranted use of fans outdoors are limited to Enclosed Alfresco like areas where conditions are similar to indoor installations.

The warranty conditions for fans installed in Enclosed Alfresco areas are as follows:

- * Fan must be shielded from wind and rain (enclosed area, min. 1.5m from edge of eave/roof).
- * The warranty will cover open circuit motor faults, and remote control faults if not related to outdoor exposure.
- * The Warranty will not cover outdoor related issues such as rusting, or failure clearly caused by water, moisture or wind.
- * The Warranty will not cover external appearance or finish of any part of the ceiling fan.
- * The Warranty will not cover wooden blades. These are recommended only to be used indoors.

The warranty does not cover Ripple Control noise/interference (identified by a periodic or intermittent hum). This must be addressed with your energy service provider.

The warranty does not cover noises or faults due to poor installation or failure to balance fans as per instructions.

Our goods come with guarantees that cannot be excluded under the Australian Consumer Law. You are entitled to a replacement or refund for a major failure and compensation for any other reasonably foreseeable loss or damage. You are also entitled to have the goods repaired or replaced if goods fail to be of acceptable quality and the failure does not amount to a major failure.

Any claim under this warranty must be made within 6 years of the date of purchase of the product. To make a warranty claim please refer to the Warranty Claim Form on the Brilliant Website: www.brilliantlighting.com.au

This warranty is given by:

Brilliant Lighting (Aust) Pty. Ltd.

ABN 37 006 203 694

956 Stud Road Rowville, VIC 3178

Phone: 03 9765 2555

Email: info@brilliant-lighting.com.au

MADE IN CHINA