



Installation Manual

MERCURY 52" CEILING FAN



20533/13 BRUSHED NICKEL



20533/14 OIL RUBBED BRONZE

YOUR BRILLIANT MERCURY CEILING FAN

Congratulations on the purchase of your new quality Brilliant Ceiling Fan. Before installation, it is most important that you read and follow the instructions in this use and care booklet, even if you feel you are quite familiar with this type of product.

Find a safe place and keep this booklet handy for future reference.

THIS IS NOT A DIY PRODUCT.

THIS PRODUCT MUST BE INSTALLED BY A QUALIFIED ELECTRICIAN

IMPORTANT SAFEGUARDS:

Read all instructions carefully, even if you feel you are quite familiar with this type of appliance. When using electrical appliances, in order to reduce the risk of fire, electric shock, and/or injury, these basic safety precautions should always be followed:

1. This appliance **MUST** be installed by a Qualified Electrical Contractor in accordance with the local regulations, and all local, state and national electrical codes. Any alterations or additions to building wiring must be completed by a licensed electrical mechanic, or person authorised by legislation to work on the fixed wiring of any electrical installation.
2. The ceiling fan must be connected to a 240V AC 50Hz power supply.
3. All electrical work must only be undertaken after disconnection of the power by removing fuses or turning off the circuit breaker, to ensure all pole isolation of the electrical supply.
4. The fan must be earthed.
5. The fan must be installed so that the blades are **at least** 2.1 metres above the floor.
6. The structure that the ceiling fan is connected to must be capable of supporting a weight of at least 45kg. The fixing must be able to support the moving weight of the fan and must not twist or work loose.
7. Make sure that the installation site will not allow the rotating fan blades to come into contact with any object and that there is a minimum clearance of 150mm (6") from the blade tip to the wall or ceiling. Please note that the bigger this clearance is the better the airflow from your fan will be.
8. **DO NOT** use outdoors. Installing the fan in a position where it could be exposed to water or moisture is dangerous. Refer to Warranty terms for Alfresco use.
9. **DO NOT** connect the fan motor to a dimmer switch. This may give an unsatisfactory performance (motor hum) and cause damage to the motor. Use **ONLY** the provided wall/remote controller for fan speed control.
10. This appliance is not intended for use by young children or infirm persons without supervision.
11. Young children should be supervised to ensure that they **DO NOT** play with the appliance.
12. It is not recommended that ceiling fans and gas appliances be operated in the same room at the same time.
13. The fan must be turned off and stopped completely before reversing the fan direction. This will prevent any damage to the motor of the fan or controller (if installed).
14. Do not insert anything into the fan blades whilst they are spinning. This will damage the blades and upset the balance of the fan causing the unit to wobble.
15. After the fan is completely installed make sure that all base and fan blade fixings are secured and tightened to prevent any problems.
16. A blade balancing kit is included. Ensure blades are balanced immediately after installation to reduce wobble and noise.
17. Because of the fan's natural movement, some connections may loosen. Check the support connections, brackets and blade attachments twice a year to make sure they remain secured. If any are loose, tighten.
18. An all-pole disconnection incorporated in the fixed wiring is to be provided, such as a n all-pole switch or a supply cord fitted with a plug.

IMPORTANT NOTE:

The important safeguards and instructions given in this manual are not meant to cover all possible conditions and situations that may occur. It must be understood that common sense, caution and care are factors which cannot be built into any product. The persons caring for and using the unit must supply these factors.

FAULT FINDER:

- Always check the "Trouble Shooting Checklist" included in this booklet before seeking warranty claim.
- Mechanical noise may be noticed on installation. Allow at least 8 hours settling-in period.
- Some fans may wobble more than others, even if they are the same models. This does not necessarily indicate a fault.

FAULT FINDER:

- Always check the “Trouble Shooting Checklist” included in this booklet before seeking warranty claim.
- Mechanical noise may be noticed on installation. Allow at least 8 hours settling-in period.
- Some fans may wobble more than others, even if they are the same models. This does not necessarily indicate a fault.

PREPARATION:

1. Unpack your ceiling fan carefully, then remove all parts and components, and lay on a cloth or soft surface to avoid damage. DO NOT lay the motor housing on its side, the housing may get damaged.
2. Before commencing installation, check that all parts are included.

NB: You may need to remove all foam packaging material to ensure there are no missing components.

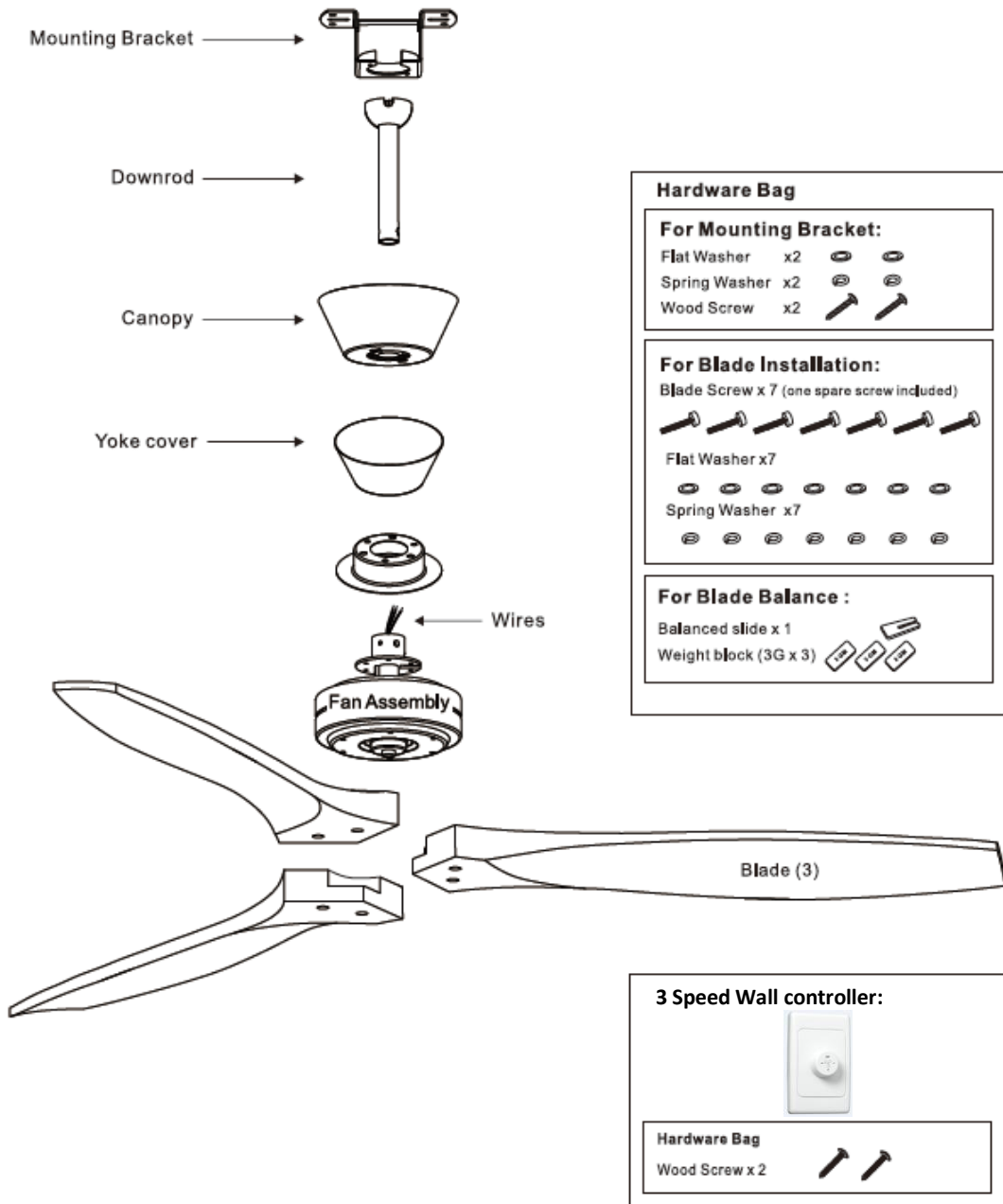



SELECTING A LOCATION:

Choose a location for mounting the fan where the blades will have **at least** 2.1 metres of clearance from the floor.

Make sure that the installation site will not allow the rotating fan blades to come into contact with any object and that there is a minimum clearance of 150mm (6") from the blade tip to the wall or ceiling. Please note that the bigger this clearance is the better the airflow from your fan will be.

DO NOT use outdoors. Installing the fan in a position where it could be exposed to water or moisture is dangerous.

If the location you have chosen does not have a suitable support beam capable of supporting 45Kg, install a brace 2" x 4" between the ceiling joists as a support medium.

ASSEMBLY:

Unlike most ceiling fans, the Brilliant Mercury Ceiling Fan requires you to attach the blades to the motor **BEFORE** mounting the motor to the ceiling.

If installing more than one ceiling fan, ensure that the blades do not get mixed up between units, as each set is dynamically balanced.

BLADE ATTACHMENT:

Align the blade with the screw holes in motor housing, and secure the blade with screw, spring washer and washer provided.

Tighten all blades screws evenly and securely to ensure quiet, wobble free operation of the fan.

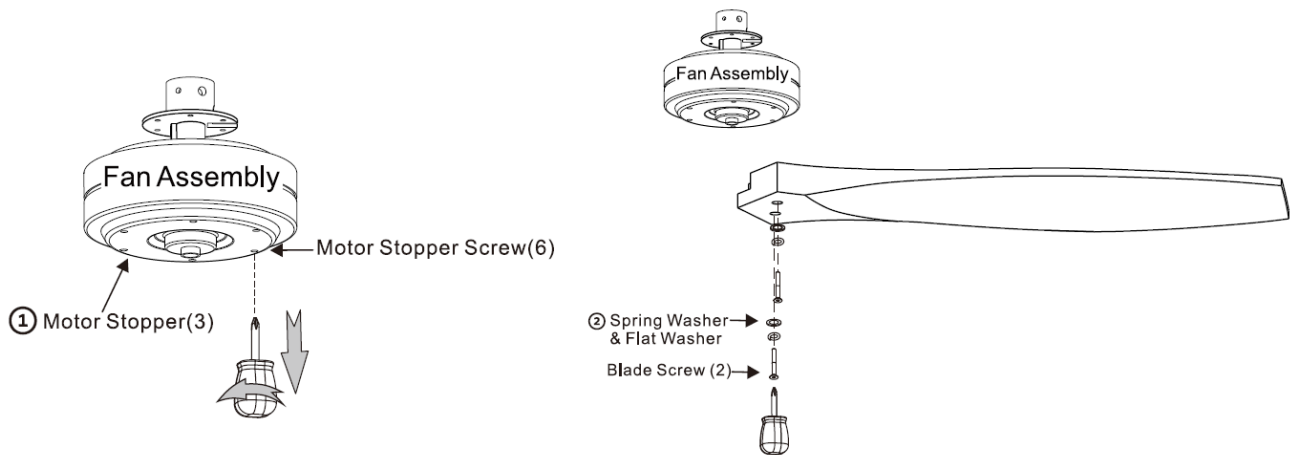

INSTALLATION:

CAUTION: Before installing the fan, make sure you have turned OFF the electricity supply.

Secure the hanging bracket to the ceiling joist or suitable structure that is capable of carrying a load of at least 45Kg, with the two long fixing screws provided. Ensure that at least 30mm of the screw is threaded into the support.

NB: The fixing screws included are designed for use when ceiling fan is secured onto timber joists. For all other surfaces, additional and suitable fixing screws for that surface will need to be purchased.

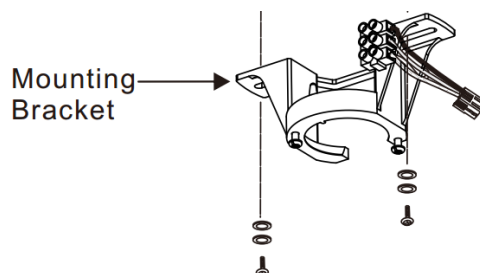

INITIAL ASSEMBLY:

1. Loosen the jam screw from the hanging ball and pull it down, remove the pin from the downrod and keep it for step 6 .
2. Remove the hanging ball and keep it for step 6.
3. Remove the cotter pin and cross pin from the downrod and keep them for step 8.

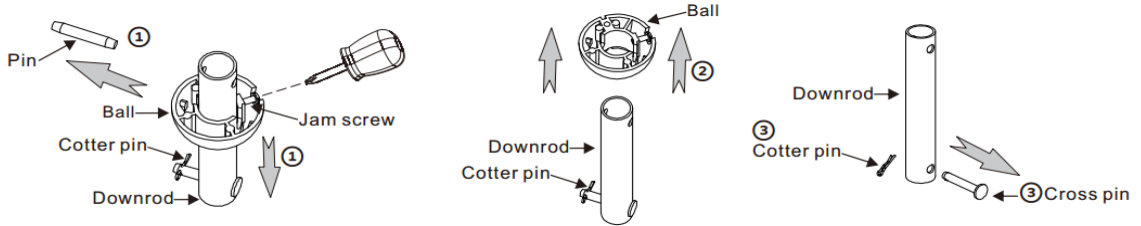

4. Loosen the two downrod jam screws at the yoke (above the motor) – do not remove.
5. Insert the downrod through the yoke cover, Deco Ring and canopy, and feed the motor wires and plug through the downrod.

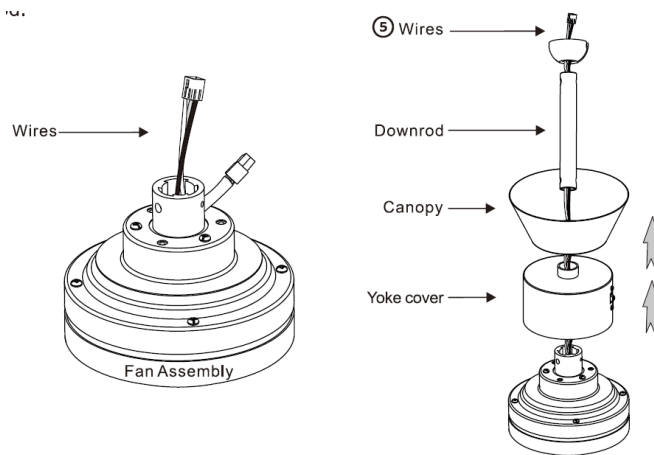

6. Insert the hanging ball through the downrod and insert the pin back into the downrod. (as removed in step 1 and 2)
7. Tighten the jam screw back into the hanging ball and ensure it is tight.
8. Insert the downrod assembly into the yoke, insert the cross pin through the yoke and downrod, securing it with the cotter pin. (as removed in step 3)
9. Tighten both downrod jam screws to further secure the downrod
10. Connect the connectors from fan to reverse capacitor firmly together. Neatly tuck the switch connectors and wires under the motor cowling as it is lowered.
11. Finally pull down the yoke cover to cover the yoke and then secure by tightening the yoke cover screw

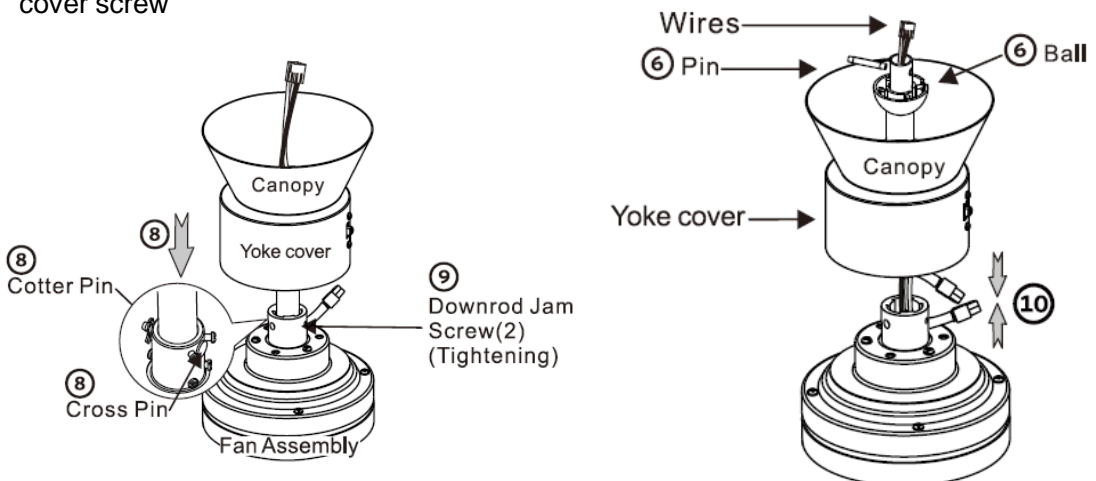

MOUNTING THE FAN

1. Lift the fan assembly onto the mounting bracket.

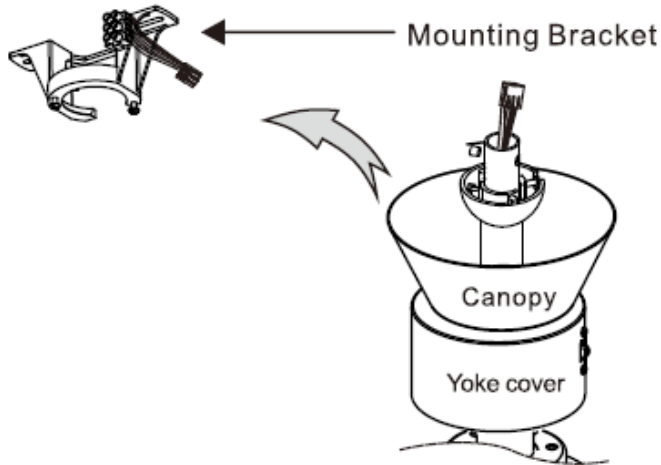

2. Rotate the fan assembly so that the groove on the ball aligns with the ridge on the mounting bracket
3. Connect the fan assembly plug to the mounting bracket plug. Ensure they are connected firmly.

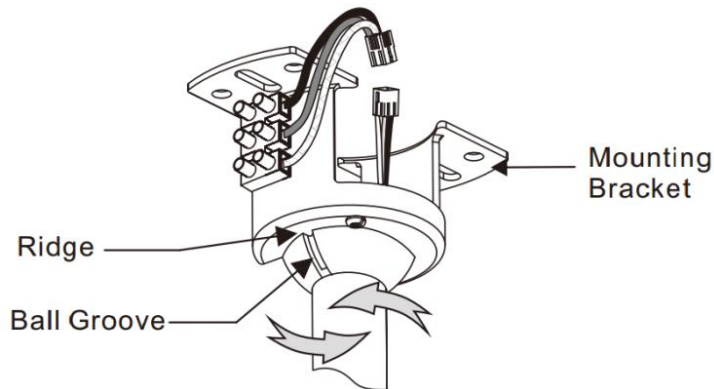

FITTING THE CANOPY

1. Place the canopy over the bracket.
2. Align the canopy holes with the screws and then tighten firmly.
3. With all electrical connections made, and fan fully installed the power can be turned on..

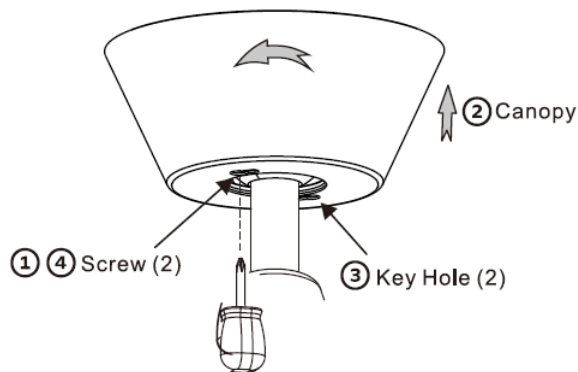



Electrical Wiring

This ceiling fan must be installed by a licensed/qualified electrician.

CAUTION: Before installing the fan, make sure you have turned OFF the electricity supply.

IMPORTANT: ENSURE ALL CABLES ARE ELECTRICALLY ISOLATED BEFORE WIRING.

Wire the incoming power cables to the terminal block mounted on the mounting plate. Wire Active, Neutral and Earth to the corresponding terminals respectively.

Check that there are no loose wire strands hanging out of the terminal block. Check that the cables are terminated into the correct position in the terminal block.

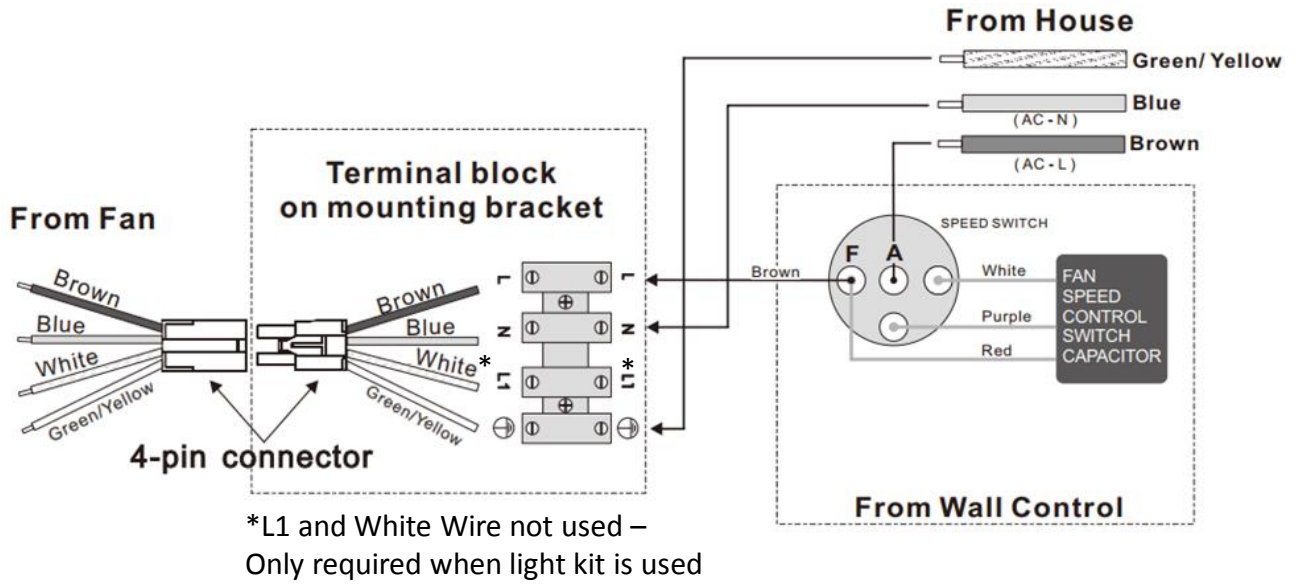

Reverse Switch

The “Summer / Winter” switch should be in left position to make the fan rotate in an anti-clockwise direction during summer. In winter, this switch should be in the right position so that the blades now move in a clockwise direction.

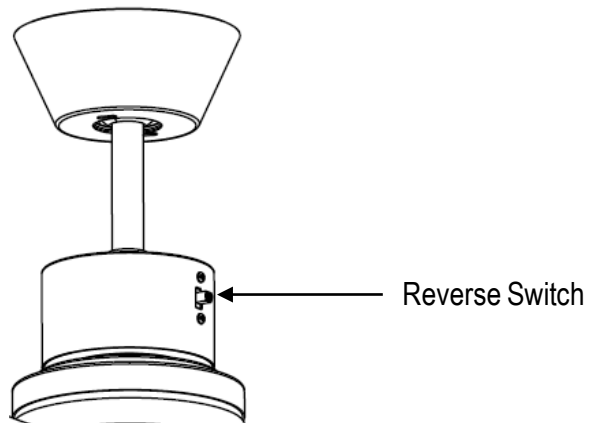
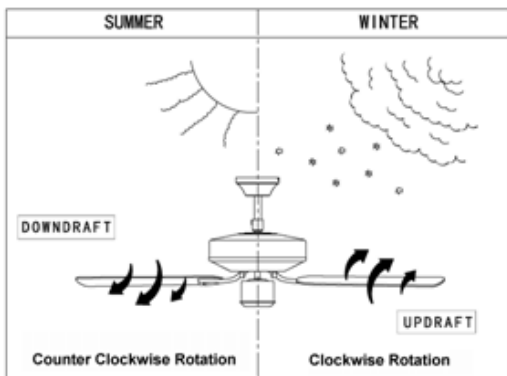



CARE & CLEANING:

Periodic cleaning of your ceiling fan is the only maintenance required.

Use a soft brush or lint free cloth to avoid scratching the finish. Please turn off electricity when you do so.

Do not use water when cleaning your ceiling fan. It could damage the motor and create the possibility of an electrical shock.

The motor has a permanently lubricated ball bearing and as such, is maintenance free.

NOISE:

The manufacturer warranty covers actual faults that may develop, but NOT minor complaints, e.g. motor operation noise - ALL ELECTRIC MOTORS ARE AUDIBLE TO SOME EXTENT; this is more obvious when the fan is operating at low speeds.

WOBBLE:

Ceiling fans are designed to move during operation because they are not generally rigidly mounted

Movement of a couple of centimetres is acceptable for safe operation.

Balancing kits included could be used to adjust the balancing.

NORMAL WEAR AND TEAR:

Threaded components working slightly loose or blade carriers even slightly bent due to vigorous cleaning or bumping can cause extra wobble and noise. THIS IS NOT COVERED UNDER WARRANTY but a little care and maintenance can reduce or prevent this problem.

BALANCING:

This fan includes a blade balancing kit. Upon initial installation, the balance kit should be used on the fan blades to reduce wobble.

The balance kit includes instructions on how to perform the balancing procedure.

Balancing the fan and reducing wobble will result in quieter operation and optimum performance.



Troubleshooting

PROBLEM	PROBABLE CAUSE	SUGGESTED REMEDY
Fan will not start	1) Fuse blown or circuit breaker has tripped 2) Loose plug connections to the fan.	1) Check mains power and reset breaker or replace fuse. 2) Check plug connections to fan.
Fan wobbles	1) Blades not balanced 2) Loose blades.	1) Use balancing kit provided 2) Insert blades ensuring primary and secondary locking tabs are engaged.
Fans sounds noisy	1) Loose fan blades. 2) Loose mounting bracket	1) Insert blades ensuring primary and secondary locking tabs are engaged. 2) Tighten mounting bracket screws
Mechanical Noise	Fan not settled in	Allow at least 8 hours of use for the fan to settle in

Technical Data

MERCURY MODEL NUMBER	RATED VOLATGE	RATED POWER FOR MOTOR
20533/13	240VAC	50W
20533/14	240VAC	50W



WARRANTY CONDITIONS:

Installation must be performed by a qualified and licensed electrician. The warranty will not apply if the ceiling fan is installed by other than a licensed electrician. Problems arising from incorrect installation are not covered by warranty. The cost of repairs and / or service call arising from incorrect installation, not due to faulty material or workmanship in accordance with the Brilliant warranty, will be payable by the purchaser at the time of repair.

This warranty is only valid for appliances used according to the manufacturer's instructions.

The manufacturer does not accept liability for any direct or consequential damage, loss or other expense arising from misuse or incorrect installation and operation of the appliance.

Warranty will only be provided where proof of qualified electrical installation is provided. Eg. Electrical Safety Certificate.

The manufacturer will not accept in home expenses unless authorisation is granted prior to work commencing, and a CA number allocated.

The in-home component of this warranty covers only actual electrical work undertaken, on or to the ceiling fan.

Where a service call is undertaken and no fault is found with the ceiling fan, or where the fault is not covered under the terms of this warranty, a call-out fee may be charged.

This product is not designed or intended for industrial or commercial use.



Brilliant Fan Warranty

Please note, this warranty voids any other warranties supplied with this product and complies with the new consumer guarantee requirements.

WARRANTY:

The benefits conferred by this warranty are in addition to all implied warranties, other rights and remedies in respect of the product, which the consumer has under Australian Consumer Law.

The original purchaser of this Brilliant Ceiling Fan is provided with the following warranty subject to the Brilliant Warranty terms and conditions as found on the Brilliant website and the following conditions.

Brilliant Lighting (Aust) Pty Ltd warrants this ceiling fans motor for a period of 6 years from the date of purchase, the first 3 years are covered by an in-home warranty. All parts deemed defective in workmanship or materials will be replaced free of charge.

This warranty is in addition to any other rights and remedies of the customer under any law. In applications not intended for household, personal or domestic use, liability is limited to replacement or reimbursement of product only.

The warranted use of fans outdoors are limited to Enclosed Alfresco like areas where conditions are similar to indoor installations.

The warranty conditions for fans installed in Enclosed Alfresco areas are as follows:

- Fan must be shielded from wind and rain (enclosed area, min. 1.5m from edge of eave/roof).
- The warranty will cover open circuit motor faults, and remote control faults if not related to outdoor exposure.
- The Warranty will not cover outdoor related issues such as rusting, or failure clearly caused by water, moisture or wind.
- The Warranty will not cover external appearance or finish of any part of the ceiling fan.
- The Warranty will not cover wooden blades. These are recommended only to be used indoors.

The warranty does not cover Ripple Control noise/interference (identified by a periodic or intermittent hum). This must be addressed with your energy service provider.

The warranty does not cover noises or faults due to poor installation or failure to balance fans as per instructions.

Our goods come with guarantees that cannot be excluded under the Australian Consumer Law. You are entitled to a replacement or refund for a major failure and compensation for any other reasonably foreseeable loss or damage. You are also entitled to have the goods repaired or replaced if goods fail to be of acceptable quality and the failure does not amount to a major failure.

Any claim under this warranty must be made within 6 years of the date of purchase of the product. To make a warranty claim please refer to the Warranty Claim Form on the Brilliant Website:

www.brilliantlighting.com.au

This warranty is given by:

Brilliant Lighting (Aust) Pty. Ltd.

ABN 37 006 203 694

956 Stud Road Rowville, VIC 3178

Phone: 03 9765 2555

Email: info@brilliantlighting.com.au

MADE IN CHINA