



S-FIRE SELK1500ISF

SELK1500ISF S-FIRE LED emergency luminaire, complete with adapter ring

Application

A perfect choice for apartments or commercial spaces

Design Specifications

- Compliant to AS/NZS 2293, emergency spacing classification D32, non-maintained
- Polycarbonate body profile, IP20, double insulation, 90mm cut-out, adapter plate cutout 110mm - 155mm, outside plate diameter 170mm
- LED charge status display and test switch
- 1.2 m flex & 3 pin plug fitted for easy plug and play installation, IC-4 rated
- Integral converter and replaceable LiFePO4 battery included, guaranteed 90 minutes emergency function.
- Intelligent automatic recharging function, 16 hour recharge time and deep discharge protection, LiFePO4 3.2V 1.5Ah



-
-
-
-
-
-
-

Technical Specification

Model No.	Description	Input Voltage (V/AC)	Power (W)	CCT (K)	Body Colour	Dimensions (mm)
SELK1500ISF	S-FIRE INTEGRATED LED EM LIGHT	240	1.6	4000	WHITE	103(L) x 46(H)

Note: Battery warranty twelve (12) months

Due to continued product and technology enhancements, data sourced from sal.net.au shall not form part of any contract and or technical performance guarantee unless expressly confirmed in writing by SAL at the time of order. Products are sold in accordance with [SAL Terms and Conditions of sale](#) and all images shown are for illustration purposes only and may vary from the actual colour or finish. Unless specifically stated, all IP ratings nominated for Interior products are from "below the ceiling".

Dimensions

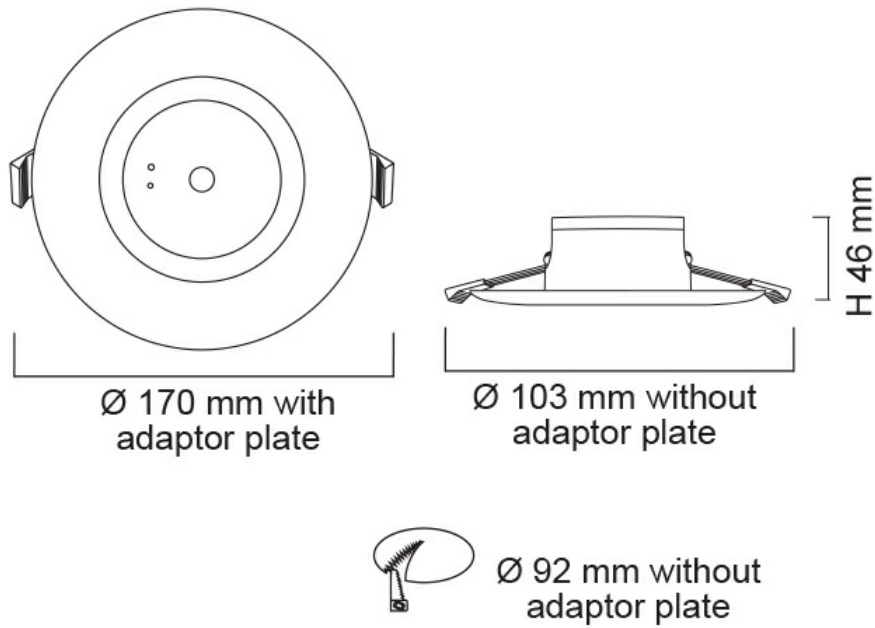

Product Images

