

# INFRARED MOTION SURFACE MOUNTED SENSORS - SENS001 & SENS002

## Specification

<b>Part No.</b>	<b>SENS001, SENS002</b>
<b>Mounting Type</b>	Surface Mounted
<b>Input voltage</b>	220-240V AC 50/60Hz
<b>Detection Range</b>	180°
<b>Detection Distance</b>	12m Max (<24°C)
<b>Detection Motion Speed</b>	0.6-1.5m/s
<b>Rated Load</b>	1200W HAL/ 300W CFL/ 150W LED
<b>Time Delay</b>	Min.10sec±3sec Max.15min±2min (Restarts from last movement)
<b>Ambient Light</b>	<3-2000lux (adjustable)
<b>Ambient Temp</b>	-20 to +40°C
<b>Working Humidity</b>	<93%RH
<b>Power Consumption</b>	approx 0.5W
<b>Installation Height</b>	1.8-2.5m
<b>Housing Material</b>	PC
<b>IP Rating</b>	IP65
<b>Warranty</b>	5 year replacement warranty



SENS001



SENS002

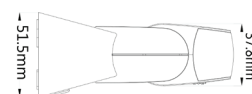
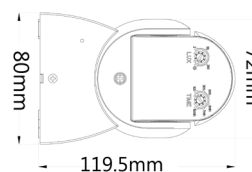

- UV resistant
- 3 wire
- Day/Night recognition
- Manual override

- (1) To operate as a light only (i.e. override sensor), turn power off for 3 seconds and then back on
- (2) To reverse the override function (i.e. re-introduce the use of the sensor), turn power off for 10 seconds and then back on

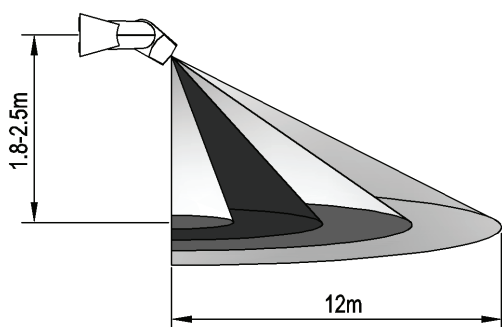

Height of installation: 1.8-2.5m

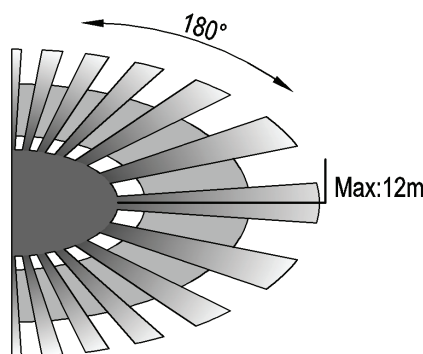

Detection Distance: Max.12m

