

Split SS316 TRI Colour LED Inground Uplighter

PRODUCT SPECIFICATIONS

Name	Split
Material	316 Stainless Steel
Colour	Stainless Steel
IP Rating	IP67
Lamp Base	Built in LED
CRI	> 80
IK Rating	IK10
Trafficable	1000kg
Wiring	Parallel
Dimmable	No
Warranty	3 Years Replacement



COLOUR TEMP

IP RATING

APPROVAL

<p>Tri-Colour By Havit</p> <p>3000K</p> <p>4000K</p> <p>5500K</p>		
---	--	--

SAMPLE ADEQUATE DRAINAGE DIAGRAM

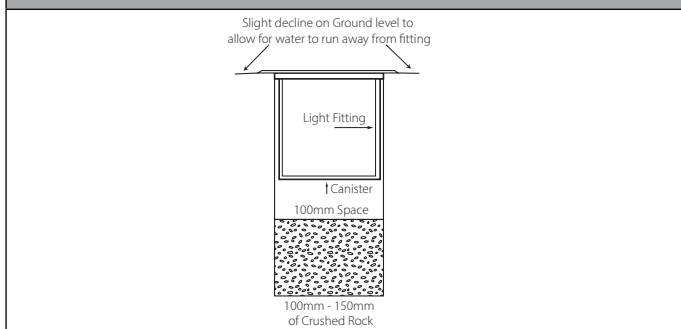

DIMENSIONS

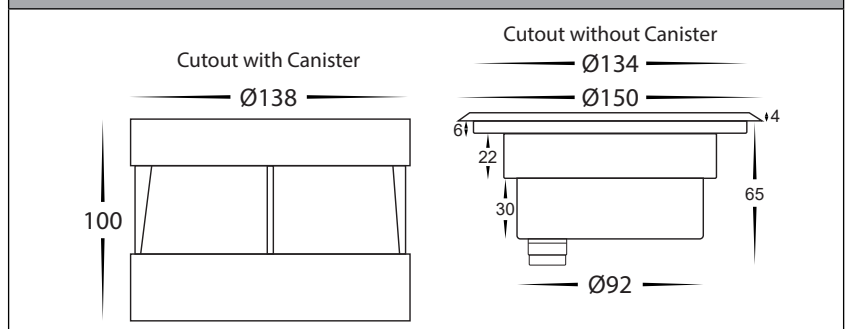

LIGHT DISTRIBUTION

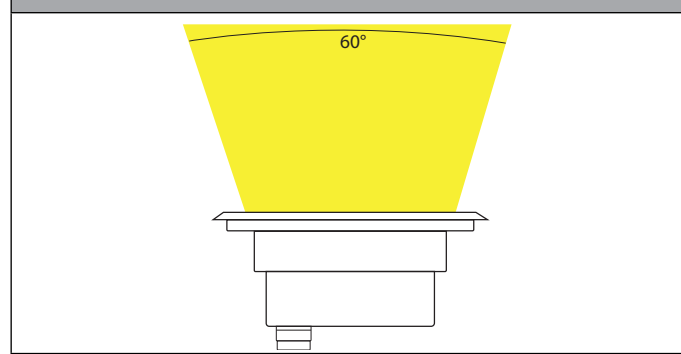

SAMPLE WIRING DIAGRAM

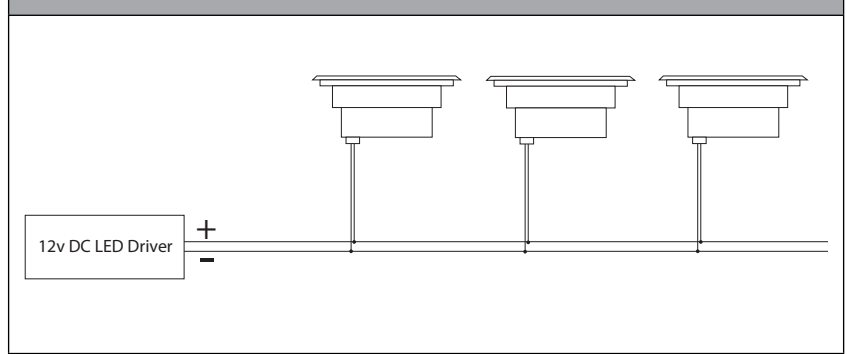

IMAGE	PART NUMBER	COLOUR TEMP	LUMENS	INPUT VOLTAGE	BEAM ANGLE	INCLUDED LED
	HV1842T	3000k 4000k 5500k	400lm 430lm 450lm	12v DC	60°	TRI Colour Built in 5w LED <small>(Must be used with a suitable 12v DC LED Driver)</small>
	HV1842-F-SH					Security face with screw holes to suit HV1842T

For More Information Contact Havit Lighting

143 Beauchamp Road
Matraville NSW 2036
Australia

Tel: 02 9381 83000
Fax: 02 9666 888
Email: sales@havit.com.au
Web: www.havit.com.au



Warranty Terms & Conditions



Additional Information