

Onder Pond Light Installation Instructions

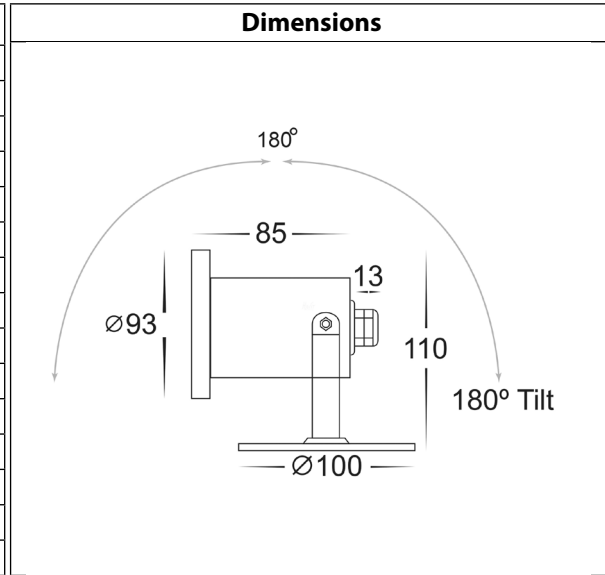

Product Specifications		
Model No.	HV1491T	HV1491RGBW
Name	Onder	
Material	316 Stainless Steel	
Colour	Stainless Steel	
IP Rating	IP68	
Input Voltage	12v DC	
Lamp Base	MR16	Built in LED
Lamp Wattage	1x 5w	
Colour Temp	TRI Colour - 3000k, 4000k, 5500k	RGBW (RGB+3000K)
Lumens	270lm, 285lm, 300lm	275lm (3000k)
CRI	> 80	
Wiring	Parallel	
Dimmable	No	
Installation Depth	1000mm Max.	
Warranty	3 Years Replacement*	



Important Safety Issues:

- This product must be installed by a qualified electrician according to AS/NZS 3000.
- Ensure all electrical mains are disconnected before any installation.
Modification of this product will void any warranty.
- Havit Lighting does not take responsibility for wrong installation, incorrect use, or use of installation material that does not belong to the system.
- All electrical connections must be watertight, If a watertight connection is not done, Warranty will be voided.
- Electrical cannot be submersed under water, If connection is under water, Warranty will be voided.
- When installing low voltage fittings, Voltage to fitting must be within +or- 5% of voltage required and cannot be installed more than 25m from LED Driver, if not within this allowance warranty will be voided.
- All 316 stainless steel fittings must have regular cleaning maintenance to avoid any tea staining from forming on fitting. (Warranty does not cover Tea Staining).
- All o-rings and seals must be in place correctly to maintain warranty.
- These instructions may be updated at any time due to product improvements, Please visit website for most current installation instructions.

Steps for Installation: HV1491T

1. Make sure that the electrical circuit is free of voltage (master switch off)
2. Place fitting in desired location using appropriate screws for application
3. Connect the cable -
4. Use an appropriate 12v DC LED Driver - DO NOT CONNECT LIGHT FITTING DIRECT TO 240V
5. Strip back cable on both fittings and cable run and twist the positive cable from fitting to positive on the cable run, then connect neutral from fitting to neutral on the cable run.
6. Solder all joins using solder with either a heat gun or butane gas torch.
7. Cover connections using an adhesive lined heat shrink or gel cap to make connection watertight. (failure to do this step will void warranty)
8. Heat the heat shrink or crimp the gel cap making sure all connections are covered. Connections cannot be submersed under water, If connections are under water, Warranty will be voided.
9. Colour temperature is preset to 3000k, to change remove cover from fitting by removing screws on front of fitting and set aside. Remove globe from fitting and move switch on side of globe to desired colour temperature.
10. Reinsert globe by aligning pins of globe with holes of lampholder and push down gently.
11. Reattach cover and insert screws making sure the seals are still in place and tighten to avoid any water penetration.
12. All connections must be carried out carefully, inspect all contacts before switching back on the electric circuit.

Steps for Installation: HV1491RGBW

1. Make sure that the electrical circuit is free of voltage (master switch off)
2. Place fitting in desired location
3. Connect the cable -
4. Use an appropriate 12v DC LED Driver and RGBW LED Controller- DO NOT CONNECT LIGHT FITTING DIRECT TO 240V
5. Do this by stripping back the cable on both fitting and cable run and twist cable together making sure all colours are correctly joined to the correct colour-
 - Black= Positive
 - Red = Red
 - Green = Green
 - Blue = Blue
 - White = White
6. Solder all joins using solder and either a heat gun or butane gas torch.
7. Cover connections using an adhesive lined heat shrink or gel cap to make connection watertight. Failure to do this will void warranty.
8. Heat the heat shrink or crimp the gel cap making sure all connections are covered.
9. Connect cable run to RGBW Controller.
10. Connect Controller to 12v DC LED Driver.
11. All connections must be carried out carefully, inspect all contacts before switching back on the electric circuit.

Must be installed by a licensed electrician

Contact Details:

143 Beauchamp Road
Matraville NSW 2036
Australia

Tel: 02 9381 8300
Fax: 02 9666 8881
Email: sales@havit.com.au
Web: www.havit.com.au

Warranty Terms & Conditions*



Additional Information

