

# Rugged USB Solutions

NEW

## USB3.0 & USB2.0



**Field installable**

### Table of contents

|            |  |     |
|------------|--|-----|
| <b>NEW</b> | <b>USB3.0</b>  |     |
|            | USB3FTV (USB-A) .....  | 88  |
|            | USB3F TV - Transversally sealed receptacles .....                            | 92  |
|            | USB3F TV - Hermetic receptacles .....  | 95  |
|            | USB3 receptacle with Self Closing Cap .....                                  | 96  |
|            | Metallic Self Closing Cap (SCC) for USB3F TV square flange receptacles ..... | 97  |
|            | High reliability USB 3.0 cordsets .....                                      | 98  |
|            | <b>USB2.0</b>  |     |
|            | USBFTV (USB-A) .....   | 99  |
|            | USBF TV - Transversally sealed receptacles .....                             | 102 |
|            | USBF TV Hermetic receptacles .....   | 104 |
|            | USBFTV - Receptacles with 360° EMI backshells .....                          | 105 |
|            | USBF TV Through bulkhead .....   | 106 |
|            | USBF TV Stand off receptacles .....  | 107 |
|            | USBF TV 2.0 receptacle with Self Closing Cap (SCC) .....                     | 109 |
|            | Metallic Self Closing Cap (SCC) for USBF TV square flange receptacles .....  | 110 |
|            | High reliability USB 2.0 cordsets .....                                      | 111 |
|            | USBF SC - Quick release series .....   | 112 |
|            | USBBF TV (USB-B) .....   | 114 |
|            | USBBF TV Stand off receptacles .....   | 117 |
|            | USBBF TV - Transversally sealed receptacles .....                            | 119 |
|            | USBB receptacle with Self Closing Cap .....                                  | 120 |
|            | Metallic Self Closing Cap (SCC) for USBB square flange receptacles .....     | 121 |
|            | Special USB adaptor for Military & Commercial Aeronautics .....              | 122 |



# USB3F TV (USB-A)

USB connection system for harsh environment



With USB Field, you can insert a standard USB 3.0 cordset into a metallic plug which will protect it from shocks, dust and fluids.  
**No hazardous on-field cabling and grounding!**  
**Also available a version including plug + cordset: see next page.**  
This metallic plug is connected into a receptacle, using a Tri Start Thread coupling mechanism (MIL-DTL-38999 series III type) with anti-decoupling device for high vibrations.

### Applications

- Embedded computers
- Data acquisition and transmission in harsh environment
- Railways
- Battelfield communication systems
- Navy systems

### Data transmission

USB specification 3.0  
Data rate: up to 5Gb/s for high speed USB

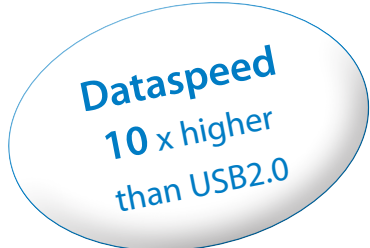

### Main characteristics

- Sealed against fluids and dusts (IP68)
- Shock, vibration and traction resistant
- No cabling operation in field and no tools required
- Improved EMI protection
- Tri Start Thread coupling mechanism (MIL-DTL-38999 series III type) with anti-decoupling device - Shell size 15
- 2 mechanical coding / polarization possibilities (receptacle insert rotation)
- USB3F TV plug retention in the receptacle: 100 N in the axis
- Mating cycles: 500 minimum

### Environmental protection

- Sealing (when mated): IP68 (temporary immersion)
- Salt spray: 48 h with nickel plating  
> 500 h with olive drab cadmium  
500 h with marine bronze shell
- Fire retardant / low smoke: UL94 V0 and NF F 16 101 & 16 102
- Vibrations: 10 – 500 Hz, 10 g, 3 axes: no discontinuity > 1micro s
- Shocks: IK06: weight of 250 g drop from 40 cm [15.75 in] onto connectors (mated pair)
- Humidity: 21 days, 43°C, 98% humidity
- Temperature range: - 40°C / +85°C

Amphenol

### Part number code: plug and receptacles without cordset.

|   |         |   |   |   |
|---|---------|---|---|---|
| Series USB3 Field TV  | USB3FTV | 2 | A | G |
| Shell type  |         |   |   |   |
| 6: plug (without cordset) - For cordset solution, see page 88.                                  |         |   |   |   |
| 2: square flange receptacle with female USB3.0 termination - For cordset solution, see page 90. |         |   |   |   |
| 7: jam nut receptacle with female USB3.0 termination - For cordset solution, see page 90.       |         |   |   |   |
| Coding (for receptacle only)  |         |   |   |   |
| A or B  |         |   |   |   |
| Shells material & finish  |         |   |   |   |
| G: aluminium shell - olive drab cadmium plating   |         |   |   |   |
| N: aluminium shell - nickel plating - ROHS compliant  |         |   |   |   |
| ZN: aluminium shell - black zinc nickel plating - ROHS compliant                                |         |   |   |   |

Examples: - plug, olive drab cadmium plating: **USB3F TV 6 G**  
- jam nut receptacle, coding B, nickel plating: **USB3F TV 7 B N**

### Plug without cordset

- Shell type 6
- Part number type: **USB3 FTV 6 x**  
**Nota:** assembling instructions on page 89

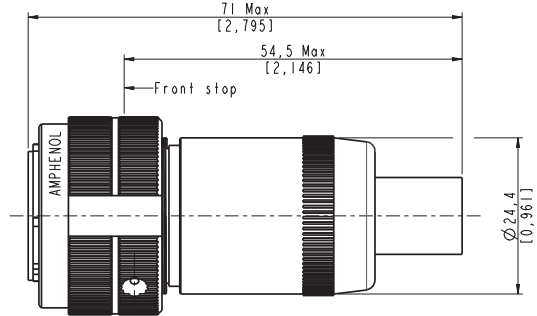

## Receptacles

- Square flange receptacle  
4 mounting holes - Shell type 2  
Part number type: **USB3 FTV 2 x**

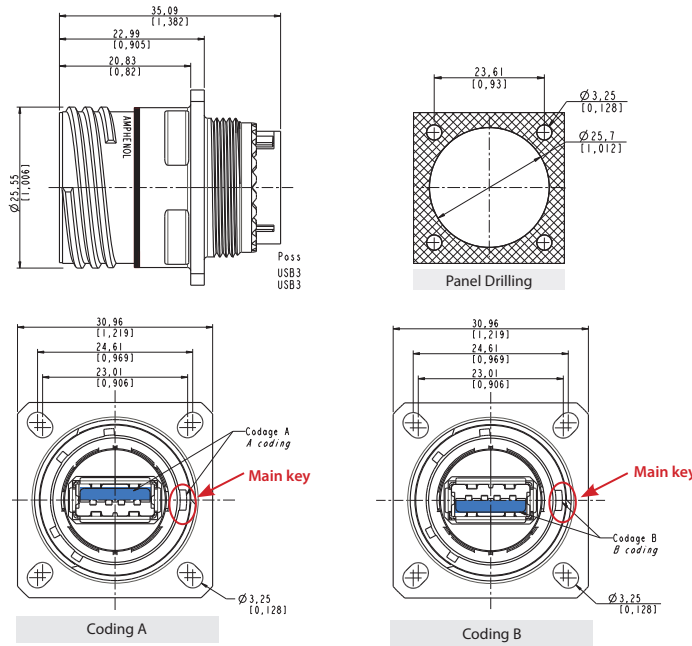

- Jam nut receptacle  
Hexagonal nut mounting - Shell type 7  
Part number type: **USB3 FTV 7 x**

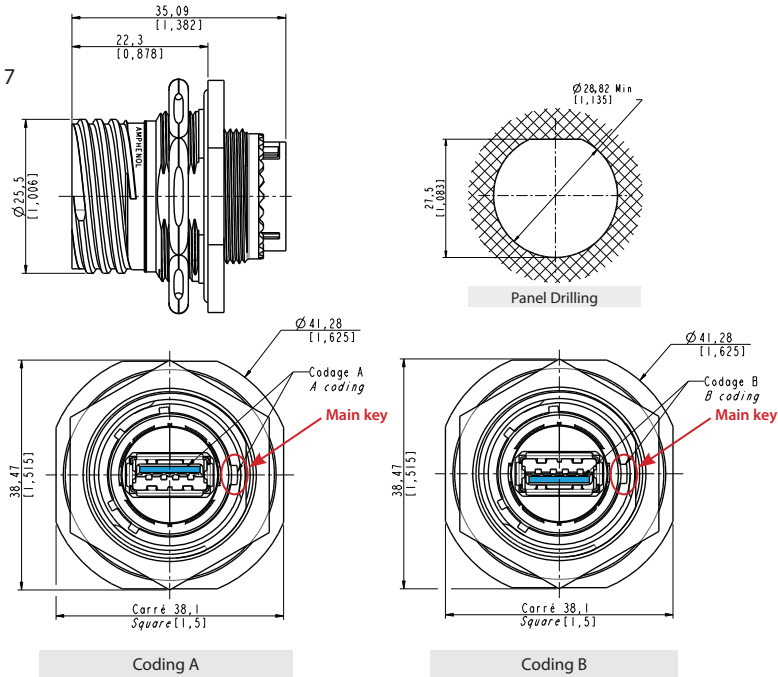

### Configuration use

For PC to peripheral application, use a crossed USB3 cable  
« CROS » type in the part number code

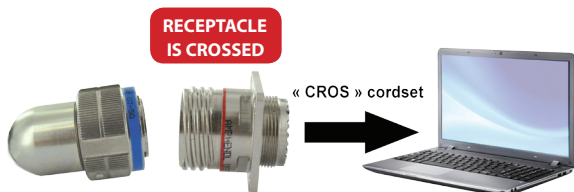

For PC to PC application, use a straight USB3 cable  
« STR » type in the part number code

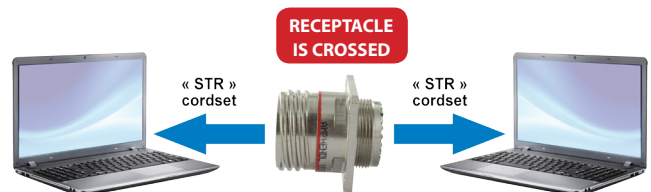

## Part number code: plugs with cordset.

|  |                          |   |   |    |   |     |
|--|--------------------------|---|---|----|---|-----|
| Series USB3 Field TV   | USB3F TV                 | 6 | A | 03 | G | STR |
| Shell type   |                          |   |   |    |   |     |
| 6: plug (with cordset)   |                          |   |   |    |   |     |
| Coding   |                          |   |   |    |   |     |
| A or B   |                          |   |   |    |   |     |
| Cordset length   |                          |   |   |    |   |     |
| 03: 0.3 m [11.81 inches]   | 10: 1 m [39.37 inches]   |   |   |    |   |     |
| 05: 0.5 m [19.68 inches]   | 15: 1.5 m [59.05 inches] |   |   |    |   |     |
| Shells material & finish   |                          |   |   |    |   |     |
| G: aluminium shell - olive drab cadmium plating                  |                          |   |   |    |   |     |
| N: aluminium shell - nickel plating - ROHS compliant             |                          |   |   |    |   |     |
| ZN: aluminium shell - black zinc nickel plating - ROHS compliant |                          |   |   |    |   |     |
| Type of cable *  |                          |   |   |    |   |     |
| CROS: high reliability USB3 cable crossed                        |                          |   |   |    |   |     |
| STR: high reliability USB3 cable straight                        |                          |   |   |    |   |     |
| OPEN: high reliability USB3 cable open ⇒ no plug at the end'     |                          |   |   |    |   |     |

**\* IMPORTANT NOTE**

- for PC to PC application, use a "CROS" type of cable
- for PC to peripheral application, use a "STR" type of cable

*See Configuration use on page 87*

Examples:

- plug, coding B, with 0.5m length of high reliability USB3 cable crossed, nickel plating: **USB3F TV 6 B 05 N CROS**
- plug, coding A, with 1m length of high reliability USB3 cable straight, olive drab plating: **USB3F TV 6 A 10 G STR**
- plug, coding B, with 0.3m length of high reliability USB3 OPEN, nickel plating: **USB3F TV 6 B 03 N OPEN**

### Plug with reinforced USB3.0 cordset

■ Shell type 6

Part number type: **USB3 FTV 6 x xx x CROS**  
**USB3 FTV 6 x xx x STR**

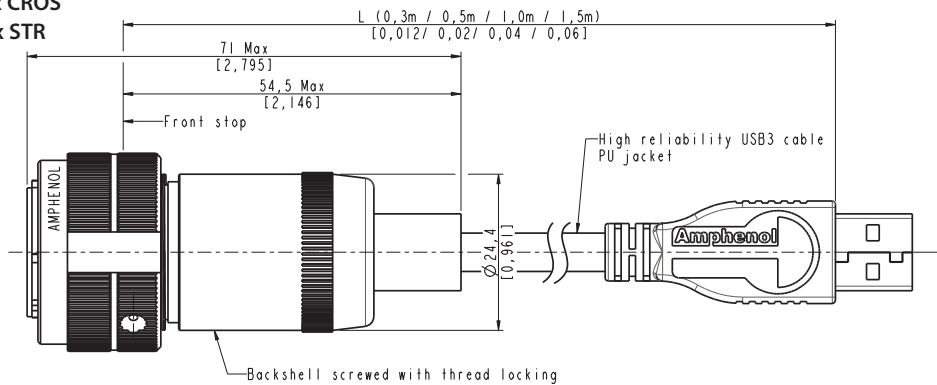

### Plug with open reinforced USB3.0 cable

■ Shell type 6

Part number type: **USB3 FTV 6 x xx x OPEN**

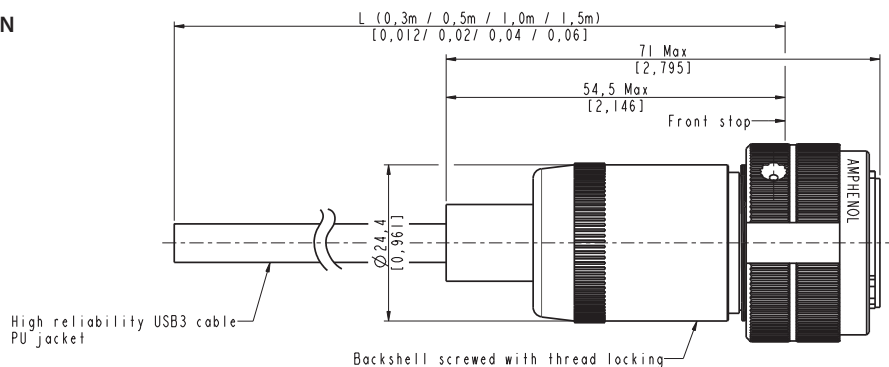

### 2 codings available for plugs

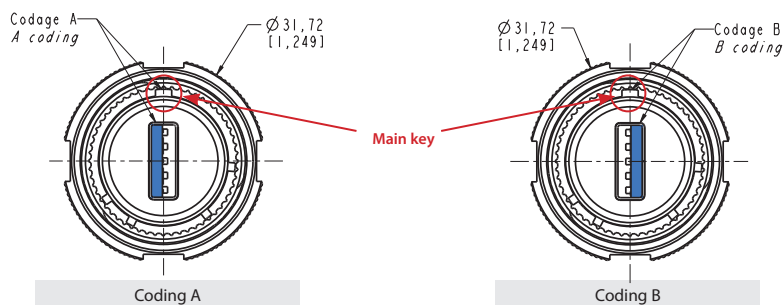

## Assembly instructions

Can be used with most the USB3.0 cordset brands : No tools required!

### Plug assembly

1. Insert the USB3 cordset into the metallic backshell
2. Insert the retention spacer laterally to the cable (this spacer is soft, in order to adapt to different shapes of overmolding) and slide the overmolding of the USB3-A plug into this retention spacer
3. Insert the friction ring laterally to the cable
4. Choose the right coding (2 positions) and insert the USB-A plug into the protective plug. Note at this step, the main key is used for polarization through the blue seal.

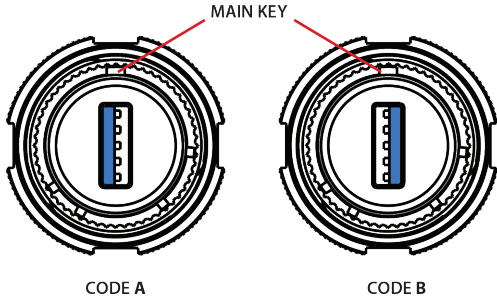

7. Screw the backshell on the plug body. A wrench can be necessary to fully tighten it, and the connection to the receptacle can help

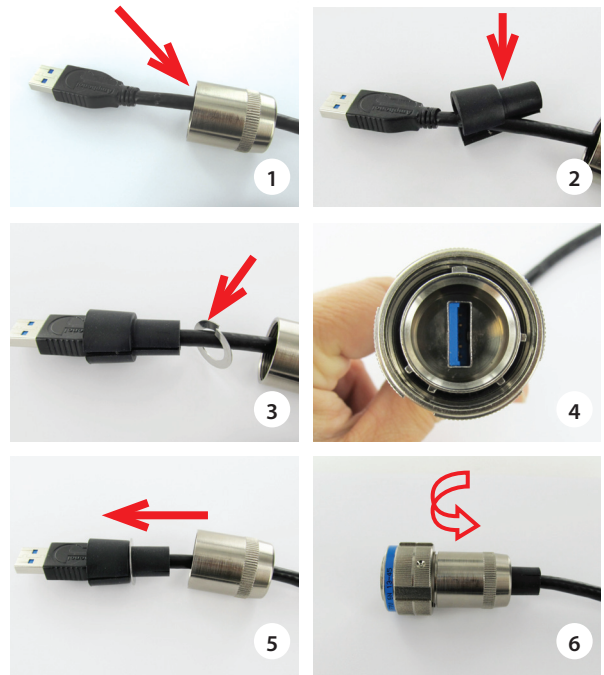

**IMPORTANT NOTE**

The sealing is done by the blue seal.



### USB3 cordset usable - Not provided

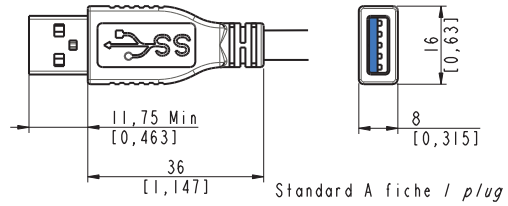

### Accessories

#### ■ Metallic caps

|  | USBF TVC | 2 | G |
|--|----------|---|---|
| <b>Connector type</b>  |          |   |   |
| 6: plug  |          |   |   |
| 2: square flange receptacle                                      |          |   |   |
| 7: jam nut receptacle  |          |   |   |
| <b>Shells material &amp; finish</b>                              |          |   |   |
| N: aluminium shell - nickel - ROHS compliant                     |          |   |   |
| G: aluminium shell - olive drab cadmium                          |          |   |   |
| BZ: marine bronze shell - ROHS compliant                         |          |   |   |
| ZN: aluminium shell - black zinc nickel plating - ROHS compliant |          |   |   |

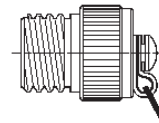

Plug Cap



Receptacle Cap

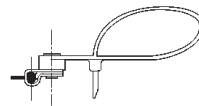

Plug Cap end

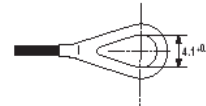

Square flange receptacle cap end

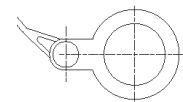

Jam Nut receptacle cap end

- Panel gasket for square flange receptacle  
Thickness: 0,8 mm [.031]  
P/n: JE15

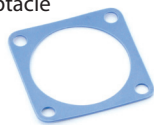





# USB3F TV (USB-A)

Transversally sealed receptacles



In some applications, a transversal sealing for the receptacle is a « must ». This will prevent fluids and dust from going through the receptacle when plug or cap are not mated to the receptacle. The sealed solution (version "S") has a compound at the rear of the receptacle below. In addition, the Sealed USB3F TV has been successfully tested in very high vibration corresponding to airplane applications.

### Applications

- Embedded computers
- Data acquisition and transmission in harsh environment
- Railways
- Battelfield communication systems
- Navy systems

### Data transmission

USB specification 3.0  
Data rate: up to 5Gb/s for high speed USB

### Main characteristics

- Sealed against fluids and dusts (IP68)
- Shock, vibration and traction resistant
- No cabling operation in field and no tools required
- Improved EMI protection
- Tri Start Thread coupling mechanism (MIL-DTL-38999 series III type) with anti-decoupling device - Shell size 15
- 2 mechanical coding/polarization possibilities by the user (receptacle insert rotation)
- USB3F TV plug retention in the receptacle: 100 N in the axis
- Mating cycles: 500 minimum

### Environmental protection

- Sealing (when mated): IP68 (temporary immersion)
- Salt spray: 48 h with nickel plating  
> 500 h with olive drab cadmium  
500 h with marine bronze shell
- Fire retardant / Low smoke: UL94 V0 and NF F 16 101 & 16 102
- Vibrations: 10 – 500 Hz, 10 g, 3 axes: no discontinuity > 1 micro s
- Shocks: IK06 ► weight of 250 g drop from 40 cm [15.75 in] onto connectors (mated pair)
- Humidity: 21 days, 43°C, 98% humidity
- Temperature range: - 40°C / +85°C

### Part number code

|  |          |     |   |    |   |     |
|--|----------|-----|---|----|---|-----|
| Series USB3 Field TV   | USB3F TV | 2 S | A | 03 | G | STR |
| Shell type   |          |     |   |    |   |     |
| 2S: square flange receptacle                                     |          |     |   |    |   |     |
| 7S: jam nut receptacle   |          |     |   |    |   |     |
| Coding   |          |     |   |    |   |     |
| A or B   |          |     |   |    |   |     |
| USB cable length   |          |     |   |    |   |     |
| 03: 0.3 m [11.81 inches]   |          |     |   |    |   |     |
| 05: 0.5 m [19.68 inches]   |          |     |   |    |   |     |
| 10: 1 m [39.37 inches]   |          |     |   |    |   |     |
| 15: 1.5 m [59.05 inches]   |          |     |   |    |   |     |
| Shells material & finish   |          |     |   |    |   |     |
| G: aluminium shell - olive drab cadmium plating                  |          |     |   |    |   |     |
| N: aluminium shell - nickel plating - ROHS compliant             |          |     |   |    |   |     |
| ZN: aluminium shell - black zinc nickel plating - ROHS compliant |          |     |   |    |   |     |
| Type of cable *  |          |     |   |    |   |     |
| ACROS: high reliability crossed USB3 cable with plug at the end  |          |     |   |    |   |     |
| ASTR: high reliability straight USB3 cable with plug at the end  |          |     |   |    |   |     |
| OPEN: high reliability cable open = no plug at the end           |          |     |   |    |   |     |

**\* IMPORTANT NOTE**  
 • for PC to PC application, use a "CROS" type of cable  
 • for PC to peripheral application, use a "STR" type of cable  
 See Configuration use on page 87

Examples: - square flange receptacle, with 0.5m length of high reliability USB3 cable crossed, coding B, nickel plating: **USB3F TV 2 S B 05 N ACROS**  
 - jam nut receptacle, with 1m length of high reliability USB3 cable straight, coding A, olive drab cadmium plating: **USB3F TV 7 S A 10 G ASTR**  
 - jam nut receptacle, with 0.3m length of high reliability USB3 cable open, coding B, olive drab cadmium plating: **USB3F TV 7 S B 03 G OPEN**

## Receptacles with USB-A cordset

### ■ Square flange receptacle

4 mounting holes: shell type 2

Part number: **USB3 FTV 2 S xx x ACROS**  
**USB3 FTV 2 S xx x ASTR**

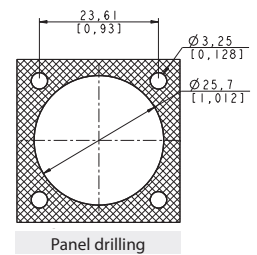
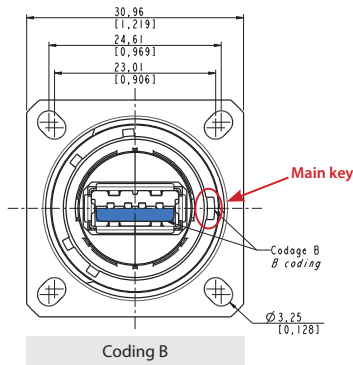
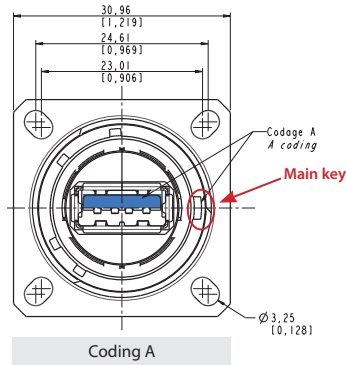
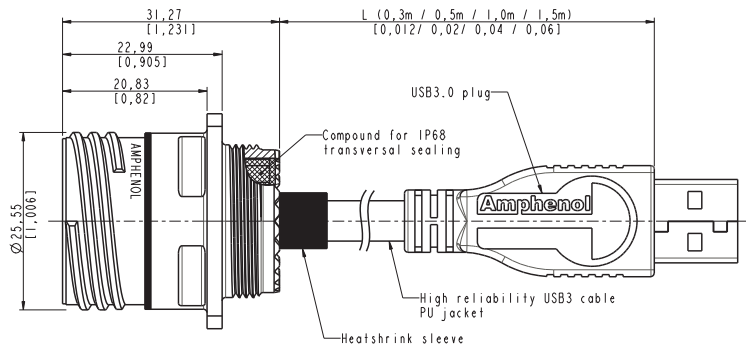

### ■ Jam nut receptacle hexagonal nut mounting: shell type 7

Part number: **USB3 FTV 7 S x xx x ACROS**  
**USB3 FTV 7 S x xx x ASTR**

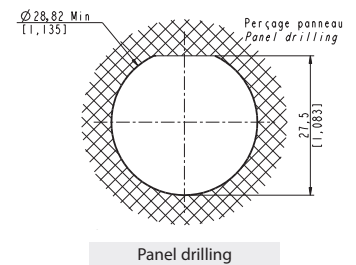
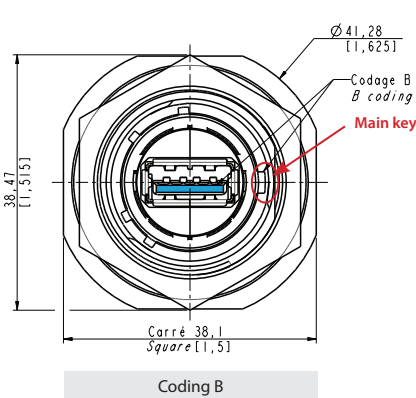
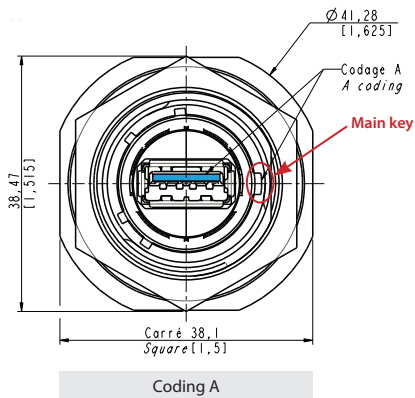
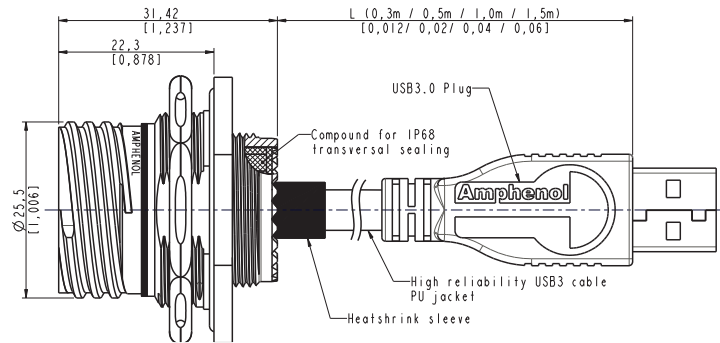

## Receptacles with open reinforced USB3.0 cable

### ■ Square flange receptacle - 4 mounting holes: shell type 2

Part number type: **USB3F TV 2 S A xx x OPEN**

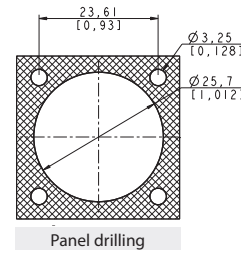
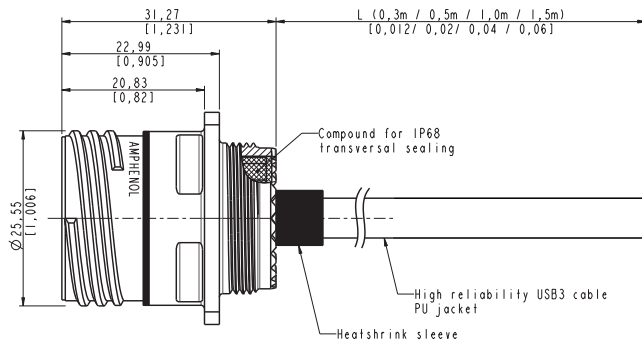

### ■ Jam nut receptacle hexagonal nut mounting: shell type 7

Part number type: **USB3F TV 7 S A xx x OPEN**

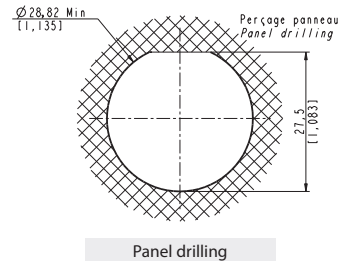
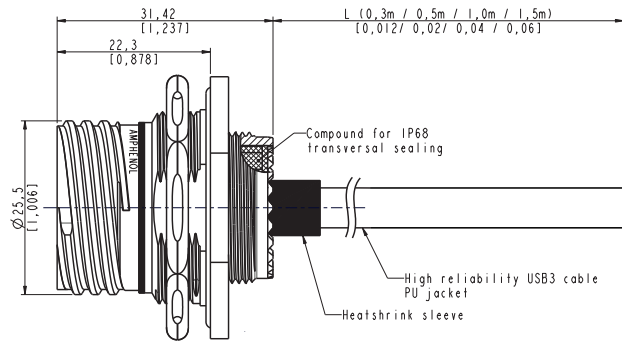





# USB3F TV

## Hermetic receptacles

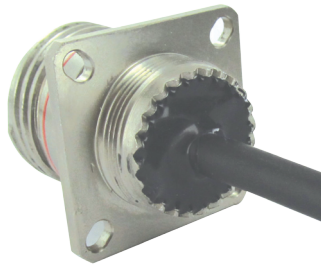

In some applications, a transversal hermiticity for the receptacle is a « must ». This will prevent gas from going through the receptacle when plug or cap are not mated to the receptacle. The hermetic solution (version "H") has a compound at the rear of the receptacle. Helium leakage is less than  $1.10^{-6}$  cm<sup>3</sup> per second [0.1 micron cubit ft per hour] at one bar [15 psi] pressure differential.

### Applications

- Embedded computers
- Data acquisition and transmission in harsh environment
- Railways
- Battelfield communication systems
- Navy systems

### Data transmission

USB specification 3.0  
Data rate: up to 5Gb/s for high speed USB

### Main characteristics

- Same as the USB3F TV (see page 76)... a complete IP68 sealing of the receptacle is added (even with no plug or no protective cap mated).
- Outside dimensions are the same as the standard USB3F TV (USB-A).
- Vibrations : the compounded version of the USBF TV has been tested in vibration following the NAS 1599 aeronautic specification (ambient temperature):  
5 - 3000 Hz, 20g, 2.5 mm [1 inch] double amplitude, 3 axes, 12 hours  
Note: this specification exceeds MIL-C-26500 requirements.

### IMPORTANT NOTE

Due to the compound, the coding of the connector must be done in the factory: use the codes A or B in the part number.

Example: USBF3TV 2H A 03 G ACROS

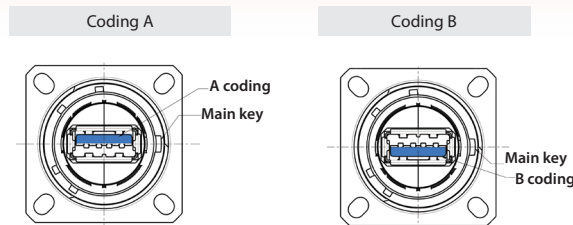

Same for jam nut receptacle.

### Part number code

|   |                 |            |          |           |          |            |
|---|-----------------|------------|----------|-----------|----------|------------|
| Series USB3 Field TV  | <b>USB3F TV</b> | <b>2 H</b> | <b>A</b> | <b>03</b> | <b>G</b> | <b>STR</b> |
| Shell type  |                 |            |          |           |          |            |
| <b>2H:</b> square flange receptacle                                     |                 |            |          |           |          |            |
| <b>7H:</b> jam nut receptacle   |                 |            |          |           |          |            |
| Coding  |                 |            |          |           |          |            |
| <b>A or B</b>   |                 |            |          |           |          |            |
| USB cable length  |                 |            |          |           |          |            |
| <b>03:</b> 0.3 m [11.81 inches]   |                 |            |          |           |          |            |
| <b>05:</b> 0.5 m [19.68 inches]   |                 |            |          |           |          |            |
| <b>10:</b> 1 m [39.37 inches]   |                 |            |          |           |          |            |
| <b>15:</b> 1.5 m [59.05 inches]   |                 |            |          |           |          |            |
| Shells material & finish  |                 |            |          |           |          |            |
| <b>G:</b> aluminium shell - olive drab cadmium plating                  |                 |            |          |           |          |            |
| <b>N:</b> aluminium shell - nickel plating - ROHS compliant             |                 |            |          |           |          |            |
| <b>ZN:</b> aluminium shell - black zinc nickel plating - ROHS compliant |                 |            |          |           |          |            |
| Type of cable *   |                 |            |          |           |          |            |
| <b>ACROS:</b> high reliability crossed USB3 cable with plug at the end  |                 |            |          |           |          |            |
| <b>ASTR:</b> high reliability straight USB3 cable with plug at the end  |                 |            |          |           |          |            |
| <b>OPEN:</b> high reliability cable open = no plug at the end           |                 |            |          |           |          |            |

### \* IMPORTANT NOTE

- for PC to PC application, use a "CROS" type of cable
  - for PC to peripheral application, use a "STR" type of cable
- See Configuration use on page 87

Examples: - square flange receptacle, with 0.5m length of high reliability USB3 cable crossed, coding B, nickel plating: **USB3F TV 2 H B 05 N ACROS**  
 - jam nut receptacle, with 1m length of high reliability USB3 cable straight, coding A, ODC plating: **USB3F TV 7 H A 10 G ASTR**  
 - jam nut receptacle, with 0.3m length of high reliability USB3 cable open, coding B, ODC plating: **USB3F TV 7 H B 03 G OPEN**

**NEW**

**ROHS COMPLIANT N & B**

# USB3 Receptacle with Self Closing Cap

**Sealing level IP54**  
(Splash and dust Proof)



This Self Closing Cap automatically protects the USB3 square flange receptacles (MIL-C-26482 type), protecting your system from dust and water projections.  
A spring automatically closes the upper part of the cap when either the USB or USB key are removed from the receptacle.

## USB3F 21 X SCC

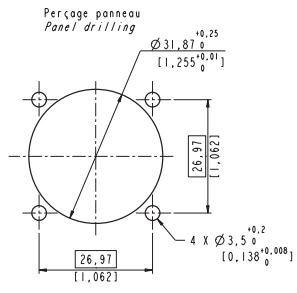
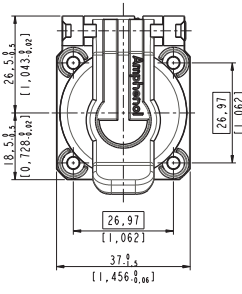
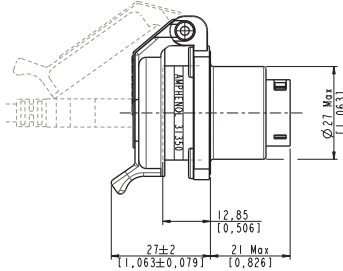

Version: USB-A (front and back termination)

| Part number * | Plating                   | Metallized inserts (EMI) |
|---------------|---------------------------|--------------------------|
| USB3F 2B SCC  | Black coated              | No                       |
| USB3F 2N SCC  | Nickel plated             | Yes                      |
| USB3F 2G SCC  | Olive drab cadmium plated | Yes                      |
| USB3F 2ZN SCC | Black Zinc Nickel         | No                       |

\* The part number includes the receptacle + the self closing cap

■ Note: Panel gasket with any of these receptacles: JE18

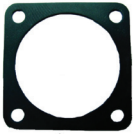

## RJ45 version, USB2.0-A version, USB-B version, & IEEE1394 version



**RJ45 version**  
(see page 25)



**USB2.0-A version**  
(see page 107)



**USB-B version**  
(see page 118)



**IEEE1394 version**  
(see page 143)

Amphenol

# Metallic Self Closing Cap (SCC)

For USB3F TV square flange receptacles.

This Self Closing cap automatically protects the USB3F TV (type A) square flange receptacles (MIL-DTL-38999 type), protecting your system from dust and water projection.

A spring automatically closes the upper part of the cap when the USB plug is removed from the receptacle.

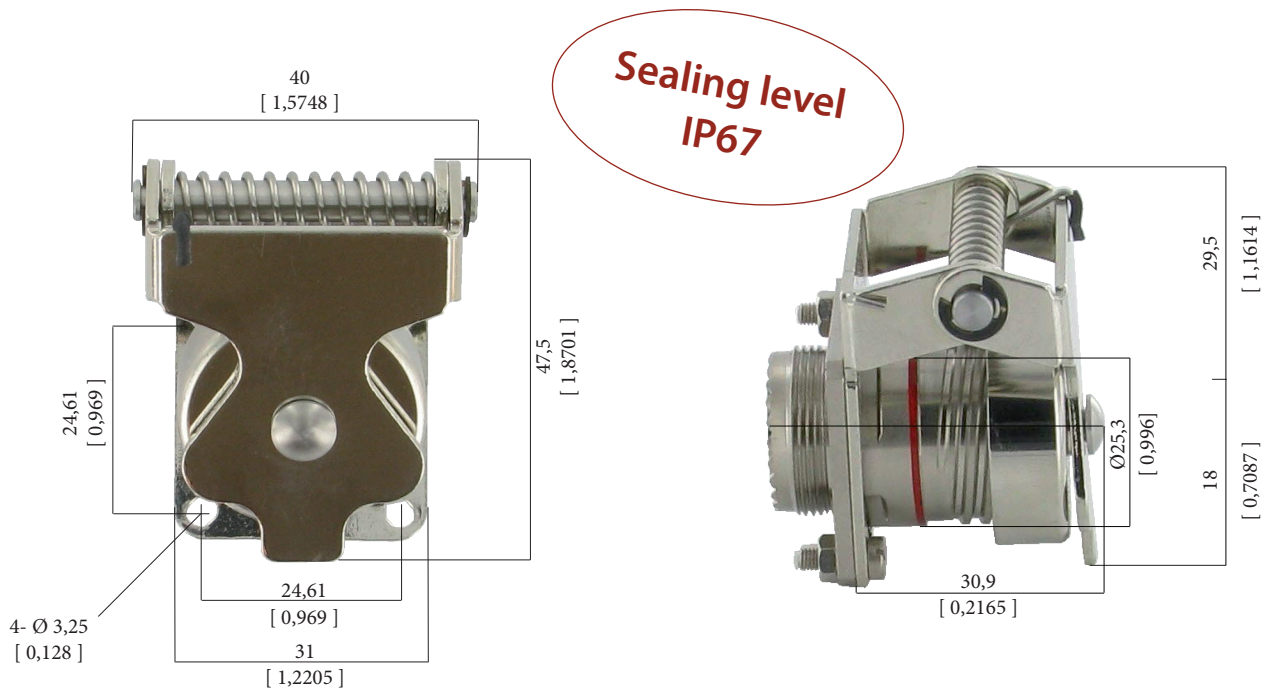

## IMPORTANT NOTE

Metal Self Closing caps are sold separately (without receptacle).



| Part number | Plating                 | P/N                |
|-------------|-------------------------|--------------------|
|             | Black - ROHS compliant  | <b>USBFTVSCCB</b>  |
|             | Nickel - ROHS compliant | <b>USBFTVSCCN</b>  |
|             | Olive drab cadmium      | <b>USBFTVSCCG</b>  |
|             | Black Zinc Nickel       | <b>USBFTVSCCZN</b> |

**Remark:** also compatible with USBFTV 2.0 (type A) & USBBFTV (type B) square flange receptacles.

USBFTV2XX (see page 106)

USBFBFTV2XX (see page 110)

■ Panel gasket for square flange receptacle (thickness: 0,8 mm [.031]):

Part number: **JE15**

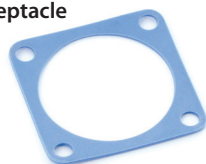



# High Reliability USB 3.0 Cordsets

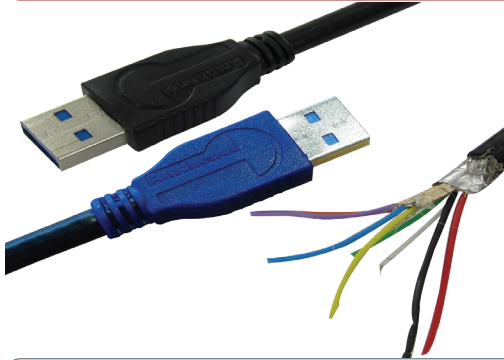

General construction: this is a USB-3.0 cable containing two 28 AWG 90Ω USB3.0 parallel shielded pair, one 28 AWG USB2.0 pair, and two 24 AWG power conductors, overall SFTP shields (SFTP = double shielding, braid and foil), jacketed in black UV resistant Polyurethane HFFR\*. Designed for fixed or portable applications in industrial and harsh environments.  
\*HFFR: Halogen Free Flame Retardant.

**Jacket compound specification:**  
Halogen Free Flame Retardant Polyether-based Polyurethane. Glossy finish. Excellent hydrolysis resistance. High microbial resistance. UV resistant. High flexibility.

### Applications

- Robotics
- Railways
- Battelfield communication
- Motion control
- CNC machines
- Industrial process

### PHYSICAL CHARACTERISTICS

|   |   |
|---|---|
| <b>DATA CONDUCTORS</b>                            | Tinned stranded copper, 7/0.13 mm nom (28 AWG)  |
| <b>DATA INSULATION</b>                            | 1 mm nom  |
| <b>COLOR DATA PAIR</b>                            | Green & white (USB2.0)<br>Yellow & blue, orange & violet (USB3.0)   |
| <b>POWER CONDUCTORS</b>                           | Tinned copper, 7/0.2 mm (24 AWG)  |
| <b>POWER INSULATION</b>                           | 1.1 mm nom  |
| <b>COLOR POWER WIRE</b>                           | Red & Black   |
| <b>SHIELDS</b>                                    | USB 3.0 pair: foil + stranded tinned copper drain wire.<br>Overall: foil + shield braiding of tinner copper wires (coverage 85%). |
| <b>JACKET</b>                                     | PU compound   |
| <b>COLOR JACKET</b>                               | Black   |
| <b>WEIGHT</b>                                     | 31 lbs/1000ft (46 kg/km)  |
| <b>OUTSIDE DIAM.</b>                              | 0.20 inch (5.7 mm nom. +/- 0.2)   |
| <b>MIN BEND RADIUS (During operation)</b>         | 57 mm (10 x O. D.)  |
| <b>MIN BEND RADIUS (During installation)</b>      | 28.5mm (5 x O.D.)   |
| <b>TEMPERATURE installation &amp; operational</b> | Plus 85°C, minus 40°C   |

### ELECTRICAL CHARACTERISTICS

#### USB3.0 Parallel pair

|                                 |               |
|---------------------------------|---------------|
| <b>Conductor resistance</b>     | ≤ 210 Ohm/km  |
| <b>Insulation resistance</b>    | ≥ 200 MOhm/km |
| <b>Capacitance (1 kHz)</b>      | nom. 43 nF/km |
| <b>Time delay</b>               | nom. 5.0 ns/m |
| <b>Time delay skew</b>          | ≤ 150 ps/10m  |
| <b>Operating voltage (peak)</b> | ≤ 100 V       |
| <b>Impedance</b>                | 90 ±7 Ohm     |
| <b>Test voltage</b>             | 500 V         |

#### USB2.0 Pair

|  |            |
|--|------------|
| Electrical requirements acc. to USB2.0 |            |
| <b>Impedance</b>                       | 90 ±15 Ohm |
| <b>Test voltage</b>                    | 500 V      |

#### Attenuation

| USB3.0 pair-db/10m |    | USB2.0 pair-db/100m |      |
|--------------------|----|---------------------|------|
| 625 MHZ            | 10 | 1 MHZ               | 4    |
| 1250 MHZ           | 15 | 4 MHZ               | 7.8  |
| 2500 MHZ           | 25 | 8 MHZ               | 11.4 |
| 5000 MHZ           | 36 | 12 MHZ              | 13.4 |
| 7000 MHZ           | 47 | 24 MHZ              | 19   |
|                    |    | 48 MHZ              | 27   |
|                    |    | 96 MHZ              | 38   |
|                    |    | 200 MHZ             | 64   |
|                    |    | 400 MHZ             | 116  |

Datas for cable alone only (without USB plug)

### IMPORTANT NOTE

⇒for PC to PC application, use a **CROSSED** cable  
⇒for PC to peripheral application use a **STRAIGHT** cable  
*see page 87*

### CORDSETS WITH A USB3 PLUG OVERMOLDED ON EACH END

|  | Length (m/ft)    | CROSSED wiring part number |             | STRAIGHT wiring part number |             |
|--|------------------|----------------------------|-------------|-----------------------------|-------------|
|  |                  | Black overmolding          |             | Blue overmolding            |             |
| <b>UNDER USB3 SPECIFICATION ≤1.8 M</b>     | 0.5 m / 1.64 ft  | USB 3 A A CROSSED          | 50 PU HFFR  | USB 3 A A STRAIGHT          | 50 PU HFFR  |
|  | 1 m / 3.28 ft    | USB 3 A A CROSSED          | 100 PU HFFR | USB 3 A A STRAIGHT          | 100 PU HFFR |
|  | 1.5 m / 4.92 ft  | USB 3 A A CROSSED          | 150 PU HFFR | USB 3 A A STRAIGHT          | 150 PU HFFR |
|  | 1.8 m / 5.91 ft  | USB 3 A A CROSSED          | 180 PU HFFR | USB 3 A A STRAIGHT          | 180 PU HFFR |
| <b>OUT OF USB3 SPECIFICATION &gt;1.8 M</b> | 2 m / 6.56 ft    | USB 3 A A CROSSED          | 200 PU HFFR | USB 3 A A STRAIGHT          | 200 PU HFFR |
|  | 2.5 m / 8.20 ft  | USB 3 A A CROSSED          | 250 PU HFFR | USB 3 A A STRAIGHT          | 250 PU HFFR |
|  | 3 m / 9.84 ft    | USB 3 A A CROSSED          | 300 PU HFFR | USB 3 A A STRAIGHT          | 300 PU HFFR |
|  | 3.5 m / 11.48 ft | USB 3 A A CROSSED          | 350 PU HFFR | USB 3 A A STRAIGHT          | 350 PU HFFR |
|  | 4 m / 13.12 ft   | USB 3 A A CROSSED          | 400 PU HFFR | USB 3 A A STRAIGHT          | 400 PU HFFR |
|  | 4.5 m / 14.76 ft | USB 3 A A CROSSED          | 450 PU HFFR | USB 3 A A STRAIGHT          | 450 PU HFFR |
|  | 5 m / 16.40 ft   | USB 3 A A CROSSED          | 500 PU HFFR | USB 3 A A STRAIGHT          | 500 PU HFFR |

# USBF TV (USB-A)

USB connection system for harsh environment



## Applications

- Embedded computers
- Data acquisition and transmission in harsh environment
- Railways
- Battelfield communication systems
- Navy systems

## Data transmission

USB specification 2.0  
Data rate: up to 480 Mbps for high speed USB

With USB Field, you can insert a standard USB 2.0 cordset into a metallic plug which will protect it from shocks, dust and fluids.

### No hazardous on-field cabling and grounding!

This metallic plug is connected into a receptacle, using a Tri Start Thread coupling mechanism (MIL-DTL-38999 series III type) with anti-decoupling device for high vibrations.

## Main characteristics

- Sealed against fluids and dusts (IP68)
- Shock, vibration and traction resistant
- No cabling operation in field and no tools required
- Improved EMI protection
- Tri Start Thread coupling mechanism (MIL-DTL-38999 series III type) with anti-decoupling device - Shell size 15
- 2 mechanical coding / polarization possibilities by the user (receptacle insert rotation)
- USBF TV plug retention in the receptacle: 100 N in the axis
- Mating cycles: 500 minimum

## Environmental protection

- Sealing (when mated): IP68 (temporary immersion)
- Salt spray: 48 h with nickel plating  
> 500 h with olive drab cadmium  
1000 h with marine bronze shell
- Fire retardant / low smoke: UL94 V0 and NF F 16 101 & 16 102
- Vibrations: 10 – 500 Hz, 10 g, 3 axes: no discontinuity > 1 micro s
- Shocks: IK06: weight of 250 g drop from 40 cm [15.75 in] onto connectors (mated pair)
- Humidity: 21 days, 43°C, 98% humidity
- Temperature range: - 40°C / +85°C

## Part number code

|   |         |   |   |   |
|---|---------|---|---|---|
| Series  | USBF TV | 2 | 1 | G |
| USB Field TV  |         |   |   |   |
| Shell type  |         |   |   |   |
| 6: plug   |         |   |   |   |
| 2: square flange receptacle   |         |   |   |   |
| 2PE: square flange receptacle with metal backshell (type 1) & with metal backshell + plastic gland (type 2) |         |   |   |   |
| 2PEM: square flange receptacle with backshell + metal gland (only for back termination type 2 = Solder)     |         |   |   |   |
| 7: jam nut receptacle   |         |   |   |   |
| 7PE: jam nut receptacle with metal backshell (type 1) & with metal backshell + plastic gland (type 2)       |         |   |   |   |
| 7PEM: jam nut receptacle with backshell + metal gland (only for back termination type 2 = Solder)           |         |   |   |   |
| Back terminations (receptacles only)  |         |   |   |   |
| 1: female USB-A   |         |   |   |   |
| 2: solder (4 tinned holes)  |         |   |   |   |
| Shells material & finish  |         |   |   |   |
| N: aluminium shell - nickel plating - ROHS compliant  |         |   |   |   |
| G: aluminium shell - olive drab cadmium plating   |         |   |   |   |
| BZ: marine bronze shell - ROHS compliant  |         |   |   |   |
| ZN: aluminium shell - black zinc nickel plating - ROHS compliant  |         |   |   |   |

- Examples:
- Olive drab cadmium plug: USBF TV 6G
  - Olive drab cadmium square flange receptacle, USB-A back terminat°: USBF TV 21G
  - Olive drab cadmium jam nut receptacle, USB-A receptacle back terminat°: USBF TV 71G
  - Nickel jam nut receptacle, solder back termination: USBF TV 72N



## Plug

- Shell type 6

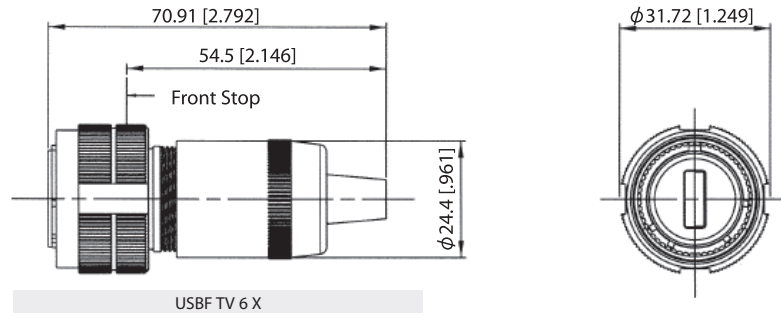

## Receptacles

- Square flange receptacle
- 4 mounting holes: shell type 2

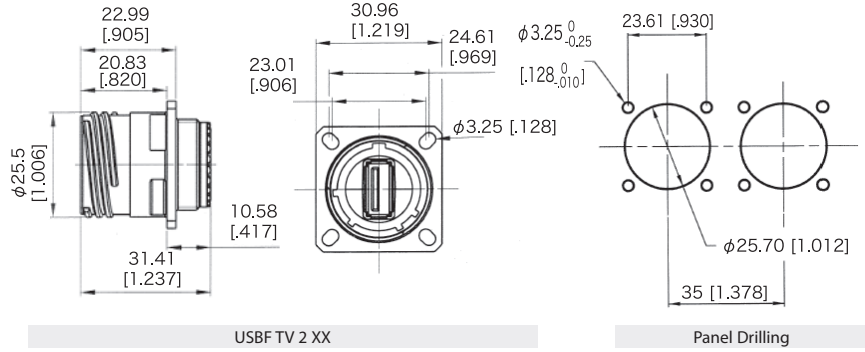

- Jam nut receptacle
- Hexagonal nut mounting: shell type 7

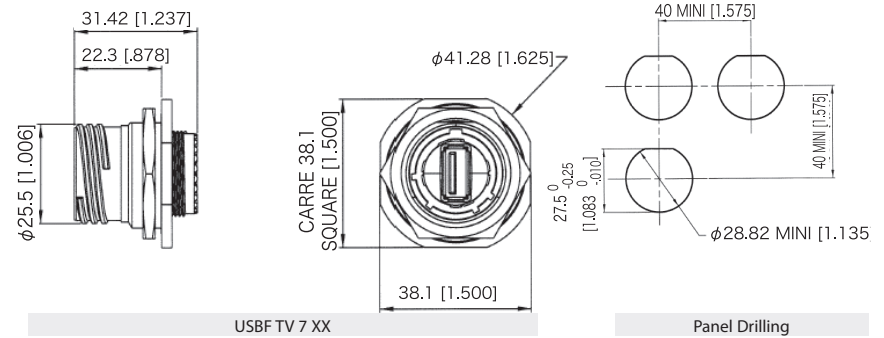

- Receptacles with backshell:
- Shell type 2PE and 7PE

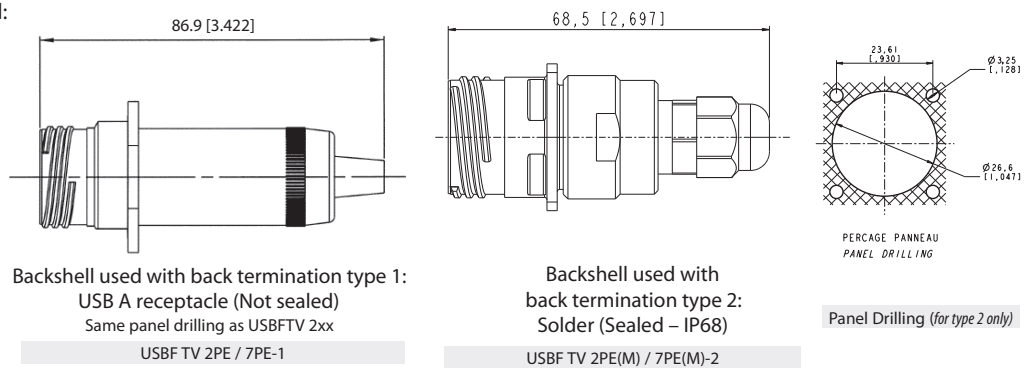

## Back terminations

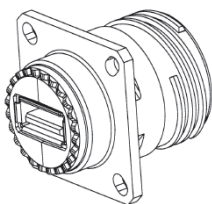

Type 1: female USB-A

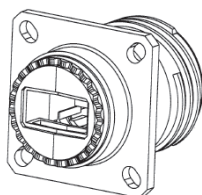

Type 2: solder 4 Tinned holes to solder your cable

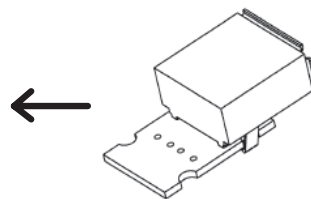

View of the PCB of the Type 2 version with 4 tinned holes for solder termination



# Assembly instructions

Can be used with most the USB cordset brands : No tools required!

### Plug assembly

1. Only if you need a full sealing (IP68): Install the white sticker around the plug, covering the 4 little holes of the overmolding
2. Insert the black O Ring around the front face of the USB A plug. This O Ring will ensure connection sealing
3. Insert the USB cordset into the metallic backshell
4. Insert the retention spacer laterally to the cable (this spacer is soft, in order to adapt to different shapes of overmolding) and slide the overmolding of the USB-A plug into this retention spacer
5. Insert the friction ring laterally to the cable
6. Choose the right coding (2 positions) and insert the USB-A plug into the protective plug. Note at this step, the main key is used for polarization.

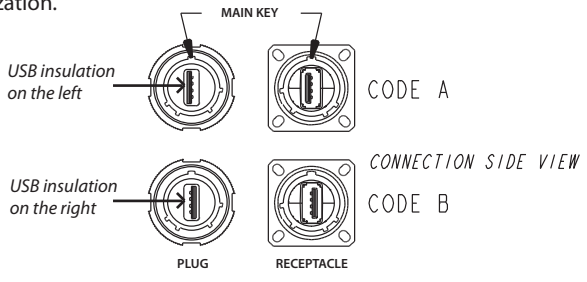

7. Screw the backshell on the plug body. A wrench can be necessary to fully tighten it, and the connection to the receptacle can help

**IMPORTANT NOTE**

The connection sealing is not done by the black retention spacer (which is slotted), but by the front face ORing (fig.2)

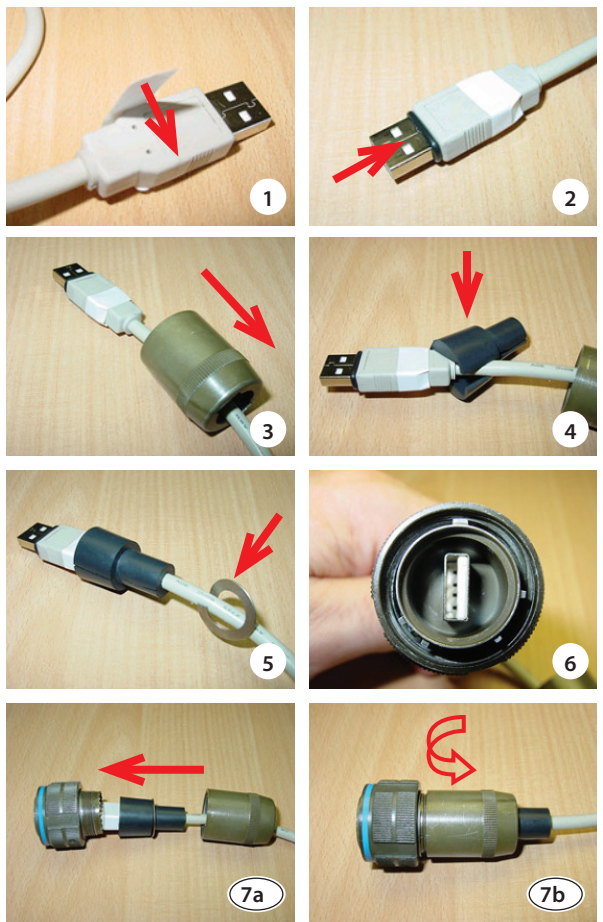

### Receptacle assembly

Insert the USB module from the rear. Reference is main key. Beware to have a coding compatible with the coding you used for the plug: on front view, the white shapes in the USBs must be on the same side.

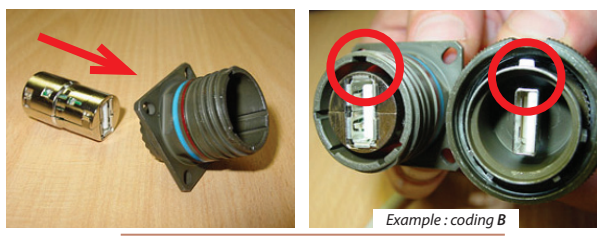

To remove the USB module, insert the removal tool USBF ODE from the Front, and push back the module.

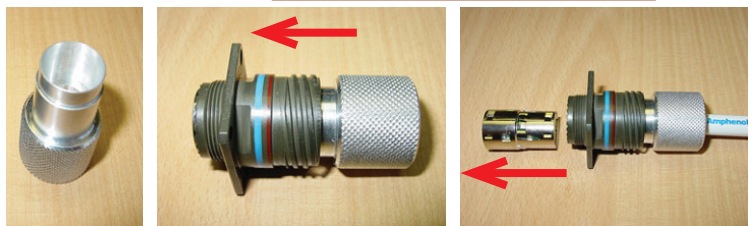

### Accessories

#### ■ Metallic caps

|  | USBF TVC | 2 | G |
|--|----------|---|---|
| <b>Connector type</b>  |          |   |   |
| 6: plug  |          |   |   |
| 2: square flange receptacle                                      |          |   |   |
| 7: jam nut receptacle  |          |   |   |
| <b>Shells material &amp; finish</b>                              |          |   |   |
| N: aluminium shell - nickel - ROHS compliant                     |          |   |   |
| G: aluminium shell - olive drab cadmium                          |          |   |   |
| BZ: marine bronze shell - ROHS compliant                         |          |   |   |
| ZN: aluminium shell - black zinc nickel plating - ROHS compliant |          |   |   |

- Panel gasket for square flange receptacle  
Thickness: 0,8 mm [.031]  
P/n: **JE15**

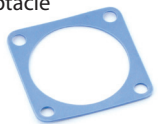

- Receptacle insert removal tool: p/n **USBF ODE**

