

Rugged Ethernet Solutions



Cable assemblies

Table of contents

 RJ45/M12: Ethernet railway cable solution	46
JUMPER railway intercoach	47



RJ45/M12: Ethernet railway cable solution



Part number: **Kit 36516** - Length 7 m [22.96 ft]

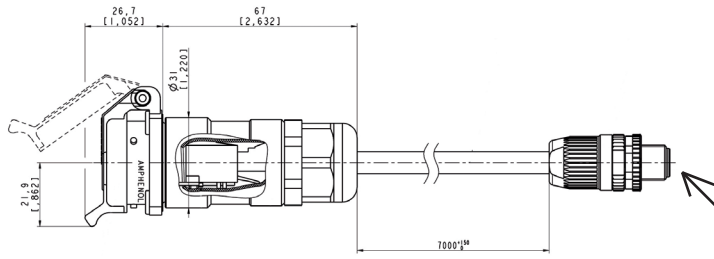

Part number: **Kit 36520** - Length 1 m [3.28 ft]

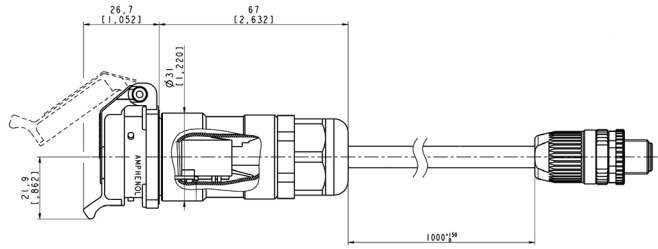

M12 D Coding

Part number: **Kit 36530** - Length 4 m [13.12 ft]

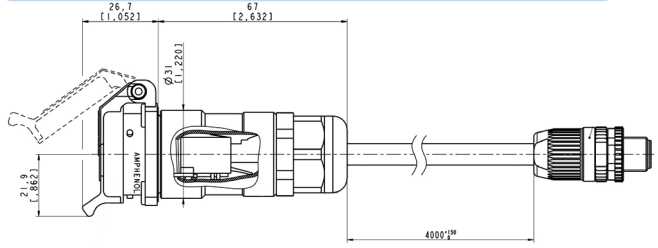

For all options:

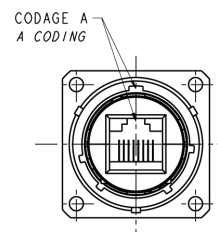
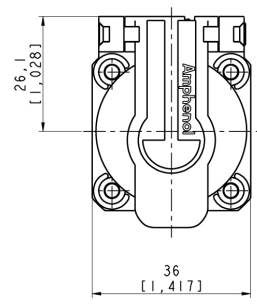
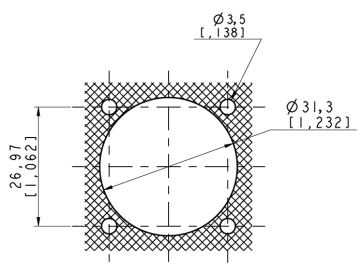



JUMPER railway intercoach

Derived from RJFTV Series

Note: for technical characteristics, please refer to RJFTV page 26.

Kit 40426 includes:

- 2 RJF TV plugs with EMI backshell assembled (coding A)
- 1 RJF SFTP cable cat 5E high reliability
- 1 conduit PCST-17B
- 2 PMAFIX straight, PG metal thread



Part number	L	P/N
	$^{+100}_0$	
	2465	Kit 40426 Rep 101
	3010	Kit 40426 Rep 102

For any other lenght, please consult us: contact@rjfield.com

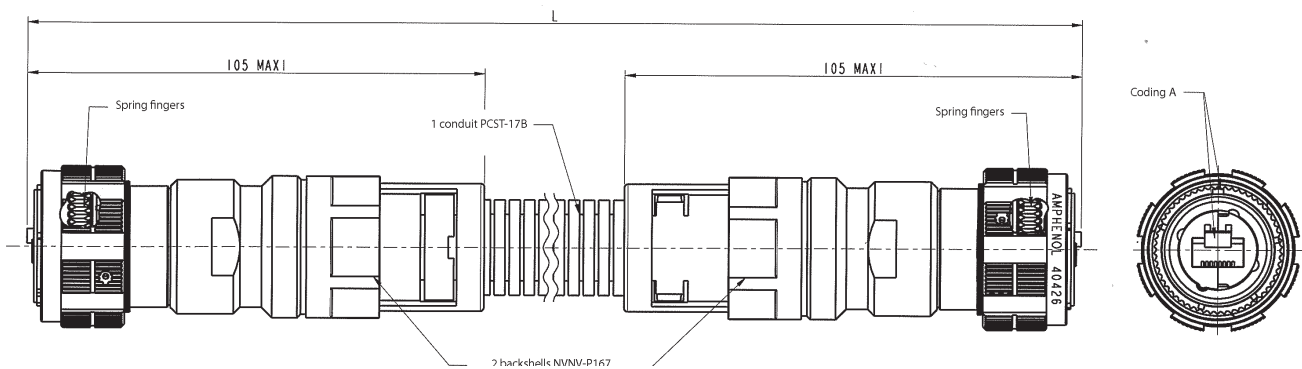

Rugged Ethernet solutions



Rugged electronics

Table of contents

NEW	Military Ethernet media converter for harsh environment	
	RES-GMC with Expanded Beam technology: military Ethernet media converter, fully MIL-STD compliant	50
	RES-GMC with butt joint fiber connector: military Ethernet media converter, fully MIL-STD compliant	52
	RJS-GMC with Expanded Beam Technology : military Ethernet Media Converter with industrial EMI compliancy	54
NEW	Military Ethernet switch for harsh environment, fully MIL-STD compliant	
	RES-SCE-AC-8US: unmanaged miniature portable Ethernet switch - 8 fast ports	58
	RES-SCE-8MG: managed miniature portable Ethernet switch - 8 Gigabit ports	60
	RESMLAC-8US-CAPS: unmanaged military Ethernet switch, MIL-DTL-38999 connectors - 8 fast ports	62
	RJSMLAC-8UG-CAPS: unmanaged military Ethernet switch, RJFTV connectors - 8 Gigabit ports	64
	RJSMLAC-8MG-CAPS: managed military Ethernet switch, RJFTV connectors - 8 Gigabit ports	66
	RESMLAC-8MG-CAPS: managed military Ethernet switch, MIL-DTL-38999 connectors - 8 Gigabit ports	68
	RESMLAC-8MG-CAPS F35: managed military Ethernet switch, MIL-DTL-38999 connectors - 8 Gigabit ports	70
	RESMLAC-28MG: managed military Ethernet switch - 24 Gigabit + 4 combo 10G ports	72
	Military Ethernet switch for harsh environment with industrial EMI compliancy	
	RJSML-8US1 and RJSML-8UG1: unmanaged military Ethernet switch, 8 fast or Gigabit ports	75
	RJSML-8MF : managed military Ethernet switch - 8 fast ports	79
	RJSML-MG7F3G : managed military Ethernet switch - 7 fast ports + 3 Gigabit ports	83

RES-GMC with Expanded Beam technology Military Ethernet media converter

For harsh environment - Fully MIL-STD compliant

Amphenol's RES-GMC is a MIL-STD rugged, unmanaged-military-grade security gateway, offering up to 2 Gigabit security gateways per device for unidirectional and data diodes solution for total isolation between two network with different security classification. The unit supports PoE on 2 ports (IEEE802.3af and IEEE802.3at).

Developed for military and harsh environment applications, the RES-GMC features mechanical packaging enhancements designed for MIL-STD-810F airborne and ground environmental compliance and high reliability.

The unit has been especially hardened to improve ingress, impact, and shock/vibration protection, as well as eliminate all moving parts through passive cooling, and interface through sealed MIL-D-38999 circular connectors.

Leveraging best-in-class switching technology, the RES-GMC series serves as a robust solution to extend your Tactical Gigabit Ethernet network connectivity of up to 120Km over fiber. Compact in size, the RES-GMC is particularly useful for remote and space-constrained locations either on ground vehicle environments or airborne.

Military applications

- Data acquisition & transmission
- Battlefield communication C4ISR
- Rugged Networks
- Combat vehicles
- Avionic & shipboard systems



Key features

■ Ethernet ports

- 1 or 2 ports 10/100/1000 or 10/100 Base TX
- 1 or 2 ports 1000 or 100 Base FX/SX/LX or WDM single fiber
- Version 2x2 ports: total isolation between the 2 networks

■ Networking

- Full wire-speed forwarding rate
- Option for Up to 2 ports PoE - IEEE802.3af, IEEE802.3at
- Store-and-forward or Pass through mechanism
- Auto MDI-II, MDI-X, FDX, HDX, Flow control
- Auto-negotiation and fixed settings via DIP switch
- Jumbo frame support
- Link loss forwarding mechanism

■ Connectors

- LAN connector type:
 - Models 1x1 ports: RJ45
 - Models 2x2 ports: D38999/24WB35SN
- Fiber connector type: CTOS 77PC or TACBeam EB4H8000. 2 fibers are used for 1x1 ports versions. 4 fibers are used for 2x2 ports versions.

■ Chassis

- Low profile rugged aluminium extrusion
- Conductively cooled w/custom internal heat-sinks
- Ingress protection against sand, dust and moisture
- Epoxy-Polyamide Paint, Per MIL-C-83286, matt texture, color: Nato green

■ Standards

- MIL-STD-1275, MIL-STD-704A, MIL-STD-461E,
- MIL-STD-810F GM, IP67/68

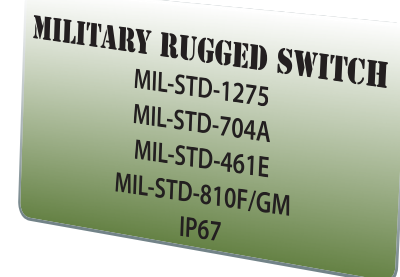

Product specifications

Performance

- 26.8 Mpps wire speed forwarding rate
- 2 Gbps maximum forwarding bandwidth
- 4K MAC address
- 2 LED indication (Speed, Link/Activity) per port
- Wire-speed reception and transmission

Standards compliance

- IEEE 802.3, 10 Mbps 10BASE-T (Ethernet)
- IEEE 802.3u, 100 BASE-TX 100 Mbps (Fast Ethernet)
- IEEE 802.3ab, 1000Base-TX
- IEEE 802.3z, 1000Base-FX Gigabit
- IEEE 802.3x Flow control

Voltage input

- VDC versions: 24VDC nominal (18-32VDC)
- VAC versions: 90-265 VAC / 47-65 Hz
- PoE versions: 48VDC

Electromagnetic

- MIL-STD-461E Electromagnetic compatibility
- CE-102, CS-114, CS-115, CS-116, RE-102, RS-103

Environmental : shock/vibration/humidity

- MIL-STD-810F, 501.4I, 501.4II, 502.4I, 502.4II, 507.4, 500.4II, 514, 516I, 516VI, 514.5, 512.4
- IP67/68

Physical

- Dimensions: 210mm (L) x 151mm (W) x 59mm (H), including connectors & hardware
- Weight: 1.260 kg

Installation

- Set of Four 4x4.5 mounting holes on bottom for mounting to any flat surface.
- Carrying handles - Optional

Cooling

- No moving parts. Passive cooling.

Operating temp

- -35°C to +75°C (-31°F to +167°F) / -35°C Cold start-up

Storage temp

- -45°C to +85°C (-49°F to +185°F)

Dimensional line drawing

All measurements are in millimeters

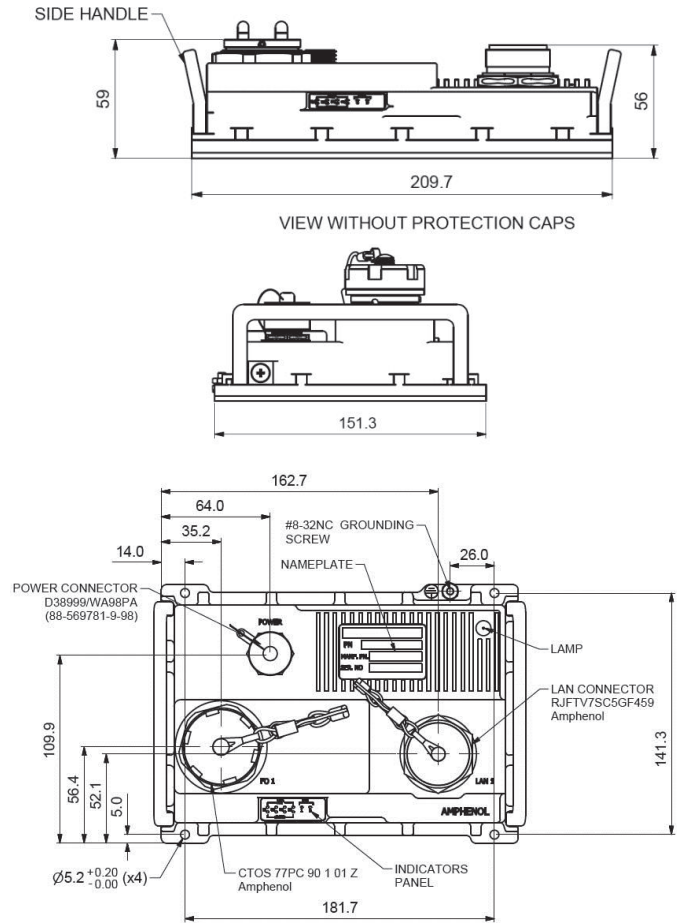

Part number code

	RESGMC	1M	G	RJF	1CTOS	OD	DC
Ports and type of optical fiber							
1M		1 copper port and 1 optical fiber port, Multimode					
1S		1 copper port and 1 optical fiber port, Singlemode					
2M		2 copper port and 2 optical fiber port, Multimode					
2S		2 copper port and 2 optical fiber port, Singlemode					
Datarate							
G		10/100/1000TX to 1000 Mbps on fiber side					
100		10/100TX to 100 Mbps on fiber side					
Copper LAN connectors							
RJF		RJ45 connector, RJ45 with MIL-DTL-38999 III Thread coupling mechanism (for 1x1 ports versions)					
TV		MIL-DTL-38999 III connector, arrangement 11-35S (for 1x1 ports versions)					
2TV		MIL-DTL-38999 III connector, arrangement 11-35S (for 2x2 ports versions)					
Optical fiber connectors							
1CTOS		CTOS connector with expanded beam, for intensive use in harsh environments, STANAG 4290					
1TACB		TACBEAM connector with expanded beam, M83526/20&21					
Protection of connectors							
OD		All connectors and caps are plated with Olive drab Cadmium					
NI		All connectors and caps are plated with Nickel (RoHs compliant MC)					
Voltage input							
DC		Unit powered with 18-36VDC					
VAC		Unit powered with 90-265 VAC / 47-65 Hz					
PoE		Unit powered with Power over Ethernet					

► For specific cable harnesses, please consult us.

RES-GMC with butt joint fiber connector Military Ethernet media converter

For harsh environment - Fully MIL-STD compliant

Amphenol's RES-GMC is a MIL-STD rugged, unmanaged-military-grade security gateway, offering up to 2 Gigabit security gateways per device for unidirectional and data diodes solution for total isolation between two network with different security classification. The unit supports PoE on 2 ports (IEEE802.3af and IEEE802.3at).

Developed for military and harsh environment applications, the RES-GMC features mechanical packaging enhancements designed for MIL-STD-810F airborne and ground environmental compliance and high reliability.

The unit has been especially hardened to improve ingress, impact, and shock/vibration protection, as well as eliminate all moving parts through passive cooling, and interface through sealed MIL-D-38999 circular connectors.

Leveraging best-in-class switching technology, the RES-GMC series serves as a robust solution to extend your Tactical Gigabit Ethernet network connectivity of up to 120Km over fiber. Compact in size, the RES-GMC is particularly useful for remote and space-constrained locations either on ground vehicle environments or airborne.

Military applications

- Data acquisition & transmission
- Battlefield communication C4ISR
- Rugged Networks
- Combat vehicles
- Avionic & shipboard systems

Key features

■ Ethernet ports

- 1 or 2 ports 10/100/1000 or 10/100 Base TX
- 1 or 2 ports 1000 or 100 Base FX/SX/LX or WDM single fiber
- Version 2x2 ports: total isolation between the 2 networks

■ Networking

- Full wire-speed forwarding rate
- Option for Up to 2 ports PoE - IEEE802.3af, IEEE802.3at
- Auto MDI-II, MDI-X, FDX, HDX, Flow control
- Auto-negotiation and fixed settings via DIP switch
- Jumbo frame support
- Option for one way fiber security

■ Connectors

- LAN connector type:
 - Models 1x1 ports: RJFTV
 - Models 2x2 ports: D38999/24WB35SN
- Fiber connector type: TVOP arrangement 11-02. 2 fibers are used for 1x1 ports versions. 4 fibers are used for 2x2 ports versions.

■ Chassis

- Low profile rugged aluminium extrusion
- Conductively cooled w/custom internal heat-sinks
- Ingress protection against sand, dust and moisture
- Epoxy-Polyamide Paint, Per MIL-C-83286, matt texture, color: Nato green

■ Standards

- MIL-STD-1275, MIL-STD-704A, MIL-STD-461E,
- MIL-STD-810F GM, IP67/68

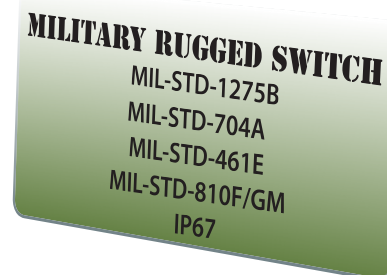

Product specifications

Performance

- 26.8 Mpps wire speed forwarding rate
- 20 Gbps maximum forwarding bandwidth
- 4K MAC address
- 2 LED indication (Speed, Link/Activity) per port
- Wire-speed reception and transmission

Standards compliance

- IEEE 802.3, 10 Mbps 10BASE-T (Ethernet)
- IEEE 802.3u, 100 BASE-TX 100 Mbps (Fast Ethernet)
- IEEE 802.3ab, 1000Base-TX
- IEEE 802.3z, 1000Base-FX Gigabit
- IEEE 802.3af, IEEE802.3at

Voltage input

- VDC versions: 24VDC nominal (18-32VDC)
- VAC versions: 90-265 VAC / 47-65 Hz
- PoE versions: 48VDC

Electromagnetic

- MIL-STD-461E Electromagnetic compatibility
- CE-102, CS-114, CS-115, CS-116, RE-102, RS-103

Environmental : shock/vibration/humidity

- MIL-STD-810F, 501.4I, 501.4II, 502.4I, 502.4II, 507.4, 500.4II, 514, 516I, 516VI, 514.5, 512.4
- IP67/68

Physical

- Dimensions: 170mm(L) x 150(W) x 65(H), including connectors & hardware
- Weight: 1 kg

Installation

- Set of Four 4x4.5 mounting holes on bottom for mounting to any flat surface.
- Carrying handles - Optional

Cooling

- No moving parts. Passive cooling.

Operating temp

- -35°C to +75°C (-31°F to +167°F) / -35°C Cold start-up

Storage temp

- -45°C to +85°C (-49°F to +185°F)

Dimensional line drawing

All measurements are in millimeters

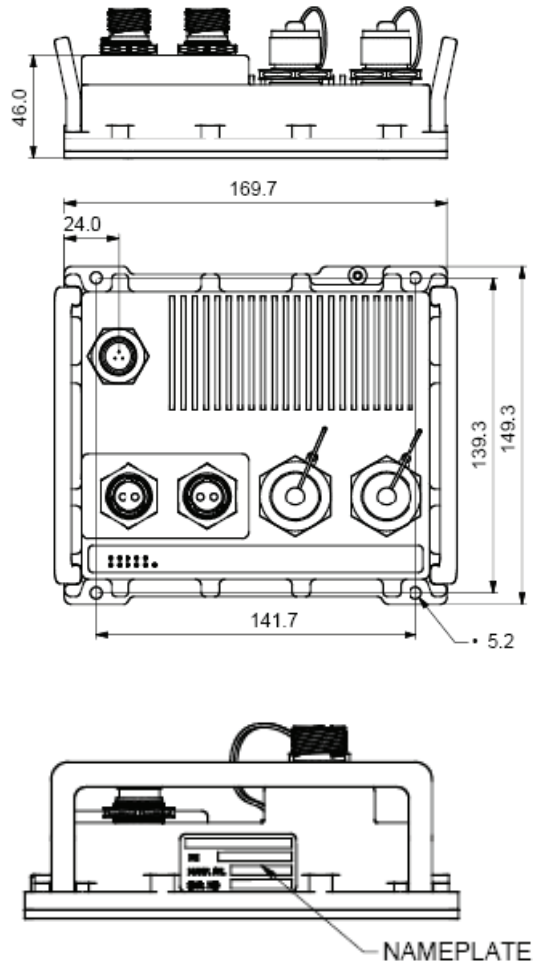

Part number code

	RESGMC	1M	G	RJF	1TVOP	OD	DC
Ports and type of optical fiber							
1M		1 copper port and 1 optical fiber port, Multimode					
1S		1 copper port and 1 optical fiber port, Singlemode					
2M		2 copper port and 2 optical fiber port, Multimode					
2S		2 copper port and 2 optical fiber port, Singlemode					
Datarate							
G		10/100/1000TX to 1000 Mbps on fiber side					
100		10/100TX to 100 Mbps on fiber side					
Copper LAN connectors							
RJF		RJ45 connector, RJ45 with MIL-DTL-38999 III Thread coupling mechanism (for 1x1 ports versions)					
TV		MIL-DTL-38999 III connector, arrangement 11-355 (for 1x1 ports versions)					
2TV		MIL-DTL-38999 III connector, arrangement 11-355 (for 2x2 ports versions)					
Optical fiber connectors							
1TVOP		1x TVOP connector with butt joint, arrangement 11-02 (for 1x1 ports versions)					
2TVOP		2x TVOP connectors with butt joint, arrangement 11-02 (for 2x2 ports versions)					
Protection of connectors							
OD		All connectors and caps are plated with Olive drab Cadmium					
NI		All connectors and caps are plated with Nickel (RoHs compliant MC)					
Voltage input							
DC		Unit powered with 18-36VDC					
VAC		Unit powered with 90-265 VAC / 47-65 Hz					
PoE		Unit powered with Power over Ethernet					

► For specific cable harnesses, please consult us.

RJS-GMC with Expanded Beam technology Military Ethernet Media Converter

For harsh environment - with industrial EMI compliancy

Amphenol's RJS-GMC is a rugged, military-grade Ethernet media converter.

Developed for military and harsh environment applications, the RJS-GMC features mechanical packaging enhancements designed for MIL-STD-810F ground environmental compliance and high reliability.

The unit has been especially hardened to improve ingress, impact, and shock/vibration protection, as well as eliminate all moving parts through passive cooling. The interfaces are protected through sealed RJFTV MIL-D-38999 circular connectors and CTOS expanded beam fiber optics connectors.

The conductive cadmium plating is suitable for most demanding EMI-RFI environments. Black paint is also offered when RoHS is required (other colors available).

Leveraging industrial grade switching technology, the RJS-GMC series serves as a robust and cost efficient solution to extend your Tactical Gigabit Ethernet network connectivity over fiber optics.

The RJS-GMC is already widely use for training and combat simulation of troops.

Military applications

- Battlefield communication C4ISR
- Rugged Networks
- Combat simulation & training of troops
- Combat vehicles

Key features

■ Ethernet ports

- 1, 2 or 4 ports 10/100/1000 BaseTX
- 1, 2 or 4 ports 1000 Base FX/SX/LX
- Versions 2x2 and 4x4 ports: total isolation between the networks

■ Networking

- Full wire-speed forwarding rate
- Store-and-forward or Pass through mechanism
- Auto MDI-II, MDI-X, FDX, HDX, Flow control
- Auto-negotiation
- Jumbo frame support
- Link loss forwarding mechanism

■ Connectors

- POWER connector : MIL-DTL-38999 III
- LAN connectors: MIL-DTL-38999 III RJFTV
- Fiber optic connectors: CTOS expanded beam

■ Chassis

- Rugged molded aluminium
- Cadmium or paint protection
- Conductively cooled with internal heat-sinks
- Ingress protection against sand, dust and moisture
- IP65/IP68 rated

■ IEEE Ethernet standards

- IEEE 802.3/u : 10 Mbps & 100 Mbps Fast Ethernet
- IEEE 802.3ab : 1000 Mbps Gigabit Ethernet
- IEEE 802.3x : Full-Duplex with Flow Control

■ Environmental specifications

- EMI emissions : FCC Class A, CE, UL, CSA
- Operating Temperature: 0°C to +50°C
- Storage Temperature: -20°C to +60°C



MIL POWER PROTECTION FOR MODELS DC-704

MIL-STD-461E
DEF-STAN-59-41
DEF-STAN-61-5
MIL-STD-704A
MIL-STD-1275A

CE102
CE03 600V spike
DCE01/DCE02
Pt 6, Iss. 5
600V input transient
Spikes: +/- 250 V for 100µs
Surges: 100 V for 50 ms at 0.5mΩ
Ripple: 14VAC pk-pk

Product specifications

Ethernet features

- 1, 2 or 4 shielded RJ45 ports 10/100/1000 BaseT(X)
- RJFTV connectors: jam nut receptacle based on MIL-DTL-38999 III
- Full / Half Duplex, Automatic or Configurable
- RJ45 MDI/MDIX Auto-crossover
- RJ45 TD and RD Auto-polarity

Dimensions

- Version 1x1: 220 x 122 x 80 mm without connectors and caps
- Version 2x2: 220 x 122 x 80 mm without connectors and caps
- Version 4x4: 360 x 160 x 90 mm without connectors and caps

Weight

- Version 1x1: approx 1.9 kg
- Version 2x2: approx 2.5 kg
- Version 4x4: approx 4.5 kg

Installation

- All versions: Set of 4 mounting holes fixed on the bottom
- Version 4x4: carrying handles fixed on the top

Power supply

Input voltage

- DC : 9-36 VDC
- DC-704 : 9-33 VDC, reverse voltage protection
- VAC : 85/264 VAC, 47/63 Hz

Input power

- Version 1x1: 3W
- Version 2x2: 6W
- Version 4x4: 12W

Connectors for power

- MIL-DTL-38999 III jam nut receptacle, olive drab cadmium or nickel
- DC & DC-704 TVx07xx0998PA: 3 cts # 20 (wire AWG 24 to 20)
- VAC TVx07xx0998P

Dimensional line drawing

All measurements are in millimeters

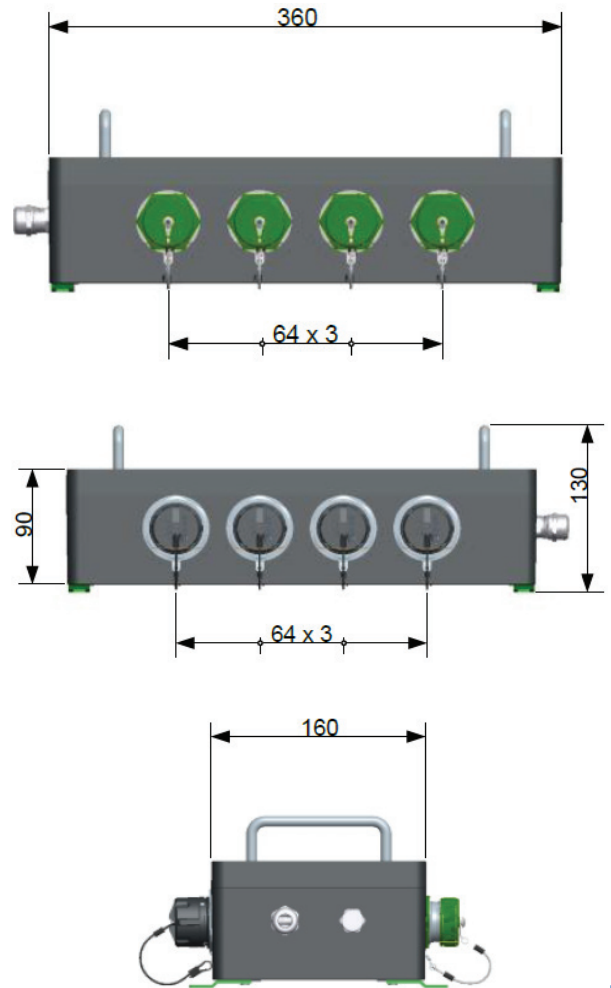

Part number code

	RJS-GMC	ML	1CTOS	MG	OD	DC-CAPS
Protection and color						
ML	Olive Drab Cadmium Plating on enclosure and receptacles					
BKN	RAL 9005 (Jet Black) Paint on enclosure, Nickel plated receptacles, ROHS compliant					
ML1019	RAL 1019 (Sand) Paint on enclosure, Olive Drab Cadmium plated receptacles					
BKN9010	RAL 9010 (White) Paint on enclosure, Nickel plated receptacles, ROHS compliant					
Number of ports						
1CTOS	1 port LAN to 1 port fiber optics, 1 RJFTV and 1 CTOS connector					
2CTOS	2 ports LAN to 2 ports fiber optics, 2 RJFTV and 2 CTOS connectors					
4CTOS	4 ports LAN to 4 ports fiber optics, 4 RJFTV and 4 CTOS connectors					
Type of fiber and datarate						
MG	Multimode, 50/125, Gigabit Ethernet					
SG	Singlemode, 9/125, Gigabit Ethernet					
MF	Multimode, 50/125, Fast Ethernet					
Protection of LAN and Power connectors and caps						
OD	Olive drab cadmium plating					
BZN	Black Zinc Nickel (RoHS compliant)					
NI	Nickel plating, bright (RoHS compliant)					
Power supply and caps						
DC-CAPS	24VDC powered, attached caps on all receptacles					
DC-704-CAPS	24VDC powered, with 704 filtering option, attached caps on all receptacles					
VAC-CAPS	85-264 VAC, 47-63 Hz, attached caps on all receptacles					

► For specific cable harnesses, please consult us.

RES-GMC-1M-FORC

Military Ethernet Media Converter with Remote Control

For fiber extension of existing systems on the Field

Amphenol's RES-GMC-1M-FORC is a MIL-STD rugged, unmanaged-military-grade Media converter, offering Gigabit communication. Developed for network deployment in harsh environment applications, the RES-GMC-1M-FORC series serves as a robust solution to extend your Tactical Gigabit Ethernet network over fiber. The fiber interface is a CTOS connector with expanded beam, designed for intensive use in severe environments.

Combining the 2 units of RES-GMC-1M-FORC with a fiber drum, your network will be extended on the field and remote controlled from safe area through fiber optics.

> Simply add 2 media converters unit 1 and unit 2 + a fiber drum

Due to extreme low consumption of unit 2 in STANDBY mode, your battery on the field will operate longer.

Operation:

- Connect the unit 1 to a command or control post in a safe area.
- Install the unit 2 together with the deployed system directly on the field, powered by battery through DC IN.
- Link the 2 units with an optical fiber harness.
- The unit 2 is remote controlled by unit 1. Once unit 1 is powered, it will wake up the unit 2.
- The deployed system will be powered from the battery, through DC OUT connector of the unit 2.
- Up to 100A can be provided to the deployed system!



Unit 1



Fiber drum



Unit 2

Military applications

- Data acquisition & transmission
- Battlefield communication C4ISR
- Rugged Networks
- Combat vehicles

Where your system can be extended through network.

Key features

- **Ethernet ports**
 - 10/100/1000 Base TX to 100/1000 Base SX-(MM) Media converter
- **Networking**
 - Full wire-speed forwarding rate
 - Store-and-forward or Pass through mechanism
 - Auto MDI-II, MDI-X, FDX, HDX, Flow control
 - Auto-negotiation and fixed settings via DIP switch
 - Jumbo frame support
 - Link loss forwarding mechanism
- **Connectors**
 - MIL-D-38999 (Power & Ethernet signals)
 - Fiber connector type: CTOS 77 PC (2 fibers for Ethernet, 1 fiber for remote control)
 - Protective caps over each connector
- **Chassis**
 - Low profile rugged aluminium extrusion
 - Conductively cooled w/custom internal heat-sinks
 - Ingress protection against sand, dust and moisture
 - Epoxy-Polyamide Paint, Per MIL-C-83286, semi-gloss
 - Color: sand mate
- **Standards**
 - MIL-STD-1275, MIL-STD-704A, MIL-STD-461E,
 - MIL-STD-810F GM, IP67/68

MILITARY RUGGED SWITCH
MIL-STD-1275B
MIL-STD-704A
MIL-STD-461E
MIL-STD-810F/GM
IP67

Product specifications

Performance

- 26.8 Mpps wire speed forwarding rate
- 2 Gbps maximum forwarding bandwidth
- 4K MAC address
- 2 LED indication (Speed, Link/Activity) per port
- Wire-speed reception and transmission

Standards compliance

- IEEE 802.3, 10 Mbps 10BASE-T (Ethernet)
- IEEE 802.3u, 100 BASE-TX 100 Mbps (Fast Ethernet)
- IEEE 802.3ab, 1000Base-TX
- IEEE 802.3z, 1000Base-FX Gigabit
- IEEE 802.3x Flow control

Power

- MIL-STD-1275B & MIL-STD-704A Surge and Spike protection
- Voltage input: 24Vdc nominal (18-36V)
- Power switching of the external DC input of unit 2 upon ON/OFF command from unit 1
- Maximum power consumption: 5W for unit 1, 10W for unit 2
- Standby consumption of unit 2: <0.1W
- Chassis grounding
- Max power at output of unit 2 (relay) : 100A

Electromagnetic

- MIL-STD-461E Electromagnetic compatibility

Environmental : shock/vibration/humidity

- MIL-STD-810F, 501.4I, 501.4II, 502.4I, 502.4II, 507.4, 500.4II, 514, 516I, 516VI, 514.5, 512.4
- IP67/68

Physical

- Dimensions: 170mm(L) x 140(W) x 110(H), including connectors & hardware
- Weight: 1.55kg for unit 1, 1.80kg for unit 2

Installation

- Set of Four 4x4.3 mounting holes on bottom for mounting to any flat surface

Cooling

- No moving parts. Passive cooling

Operating temp

- -35°C to +75°C (-31°F to +167°F) / -35°C Cold start-up

Storage temp

- -45°C to +85°C (-49°F to +185°F)

Dimensional line drawing

All measurements are in millimeters

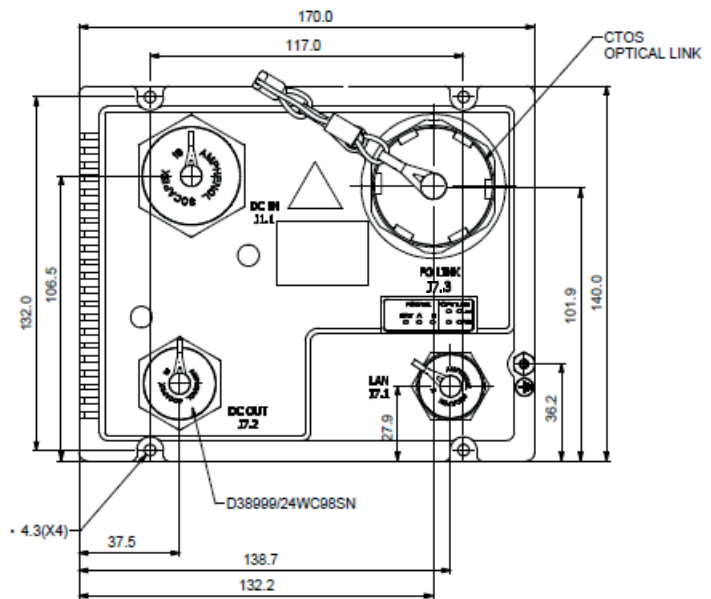
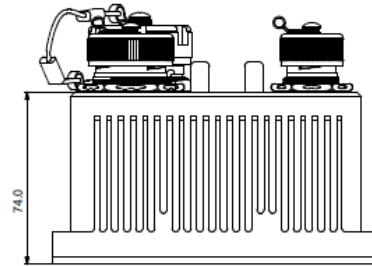
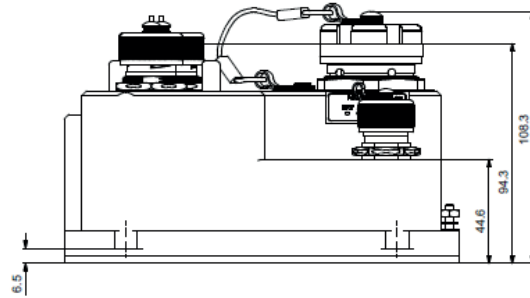

		Description
Part number	RES-GMC-1M-FORC-1	MIL-STD Rugged Gigabit Media Converter unit 1, 1x RJF connector, 1x fiber CTOS connector, MM, SX
	RES-GMC-1M-FORC-2	MIL-STD Rugged Gigabit Media Converter unit 2, 1x RJF connector, 1x fiber CTOS connector, MM, SX, remote controlled by unit 1
	CTOS drum	Please consult us

► For specific cable harnesses, please consult us.

RES-SCE-AC-8US

Unmanaged miniature portable Ethernet switch - 8 fast ports

Military ethernet switch for harsh environment - Fully MIL-STD compliant

Amphenol's RES-SCE-AC-8US is a MIL-STD rugged, unmanaged-military-grade Ethernet switch, offering 8 Fast Ethernet 10/100 Ports. The portable rugged Ethernet switch is intended for unmanned vehicles or man packable command post.

Developed for SWaP (Size Weight and Power) and mobile portable military applications, the RES-SCE-AC-8US features mechanical packaging enhancements designed for MIL-STD-810F airborne and ground environmental compliance and high reliability. The unit has been especially hardened to improve ingress, impact, and shock/vibration protection, as well as eliminate all moving parts through passive cooling, and interface through sealed MIL-SCE circular connectors.

Leveraging best-in-class switching technology, the RES-SCE-AC-8US serves as a robust solution for providing local area network (LAN) connectivity to IP-enabled computing and net-centric devices. Compact in size, the RES-SCE-AC-8US is particularly useful for expanding port density in space-constrained airborne and ground vehicle environments.

Military applications

- Unmanned Vehicles
- Battlefield communication C4ISR
- Mobile communications
- Avionic & shipboard systems



SWaP

Key features

- **Ethernet ports**
 - 8 x switched 10/100 (Fast Ethernet) ports
- **Networking**
 - Full wire-speed forwarding rate
 - Store-and-forward mechanism
 - Auto MDI-II, MDI-X
 - Auto-negotiation protocol
 - Address look-up
- **Connectors**
 - Power + LAN connector : SCE2-B-76A06-07SN-001
- **Chassis**
 - Low profile rugged aluminium extrusion
 - Conductively cooled w/ custom internal heat-sinks
 - Ingress protection against sand, dust and moisture
 - Epoxy-Polyamide Paint, Per MIL-C-83286, matt texture, color: Nato green
- **Standards**
 - MIL-STD-461E, MIL-STD-810F/G/GM, IP67/68
- **Voltage operation**
 - 5VDC (USB) INPUT, shared with LAN Port Number 1
- **Activity status**
 - Indicators for Power and LAN activity (light off by default)
 - STATUS pushbutton to turn on the indicators

MILITARY RUGGED SWITCH
MIL-STD-461E
MIL-STD-810F/G/GM
IP68

Product specifications

Performance

- 128K byte of SRAM for frame buffering
- 2.0 Gbps high-performance memory bandwidth
- LED indication (speed, link/activity) per port - Optional
- Wire-speed reception and transmission
- Integrated address look-up engine
- Automatic address learning

Standards compliance

- IEEE 802.3 10 Mbps 10BASE-T (Ethernet)
- IEEE 802.3u 100BASE-TX 100 Mbps (Fast Ethernet)
- IEEE 802.3x flow control

Power

- Voltage input: 5Vdc nominal - Optional USB sourcing
- Power consumption: 2W typical
- Chassis grounding

Electromagnetic

- MIL-STD-461E electromagnetic compatibility
- CE-102, CS-114, CS-115, CS-116, RE-102, RS-103

Environmental

- MIL-STD-810F/G/GM
- Random vibration (514.5I), Bench handling (516.6VI), High temp (501.5I, II), Low temp (502.5I), Humidity (507.5II), Air pressure (500.5I, II), Blowing rain (506.5I), Immersion (512.5I), Salt atmosphere (509.5I), Blowing dust (510.5I), Loose cargo vibration (514.6II), Wind analysis
- IP67/68

Physical

- Dimensions: 82.2mm (L) x 61.4 (W) x 26 (H), Not including connectors Dust Caps.
- Weight: 140g - Not including dust caps

Installation

- Portable, flat for mounting to any flat surface.

Cooling

- No moving parts. Passive cooling.

Operating temp

- -35°C to +75°C (-31°F to +167°F) / -35°C Cold start-up

Storage temp

- -45°C to +85°C (-49°F to +185°F)

Dimensional line drawing

All measurements are in millimeters

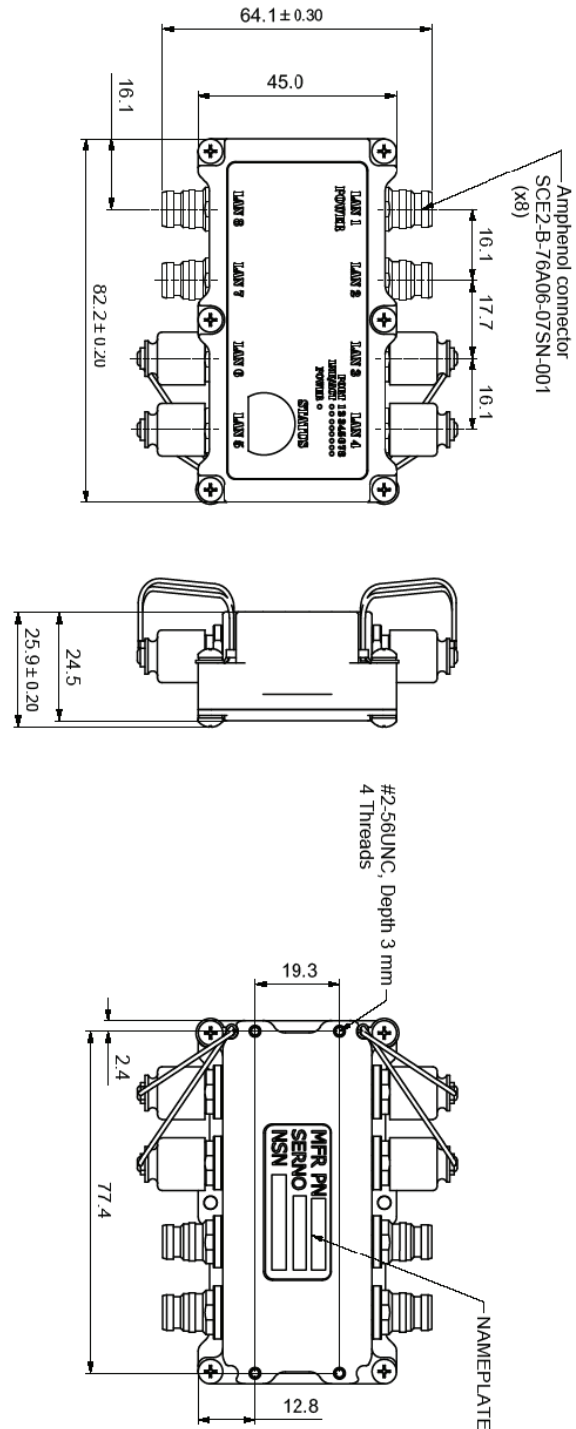

Part number code	Description
RES-SCE-AC-8BUS	MIL-STD Portable Unmanaged Ethernet switch with 8 ports 10/100TX
RES-SCE-8US-CBL-PWR-2M	Power cordset for RES-SCE-AC-8BUS, 1 side with SCE2B-L1K-0607-PN Latch release, 1 side with 1 USB civilian for power supply, cable 2m long
RES-SCE-8US-CBL-LAN-2M	LAN cordset for RES-SCE-AC-8BUS, valid for LAN 2 to 8, 1 side with SCE2B-L1K-0607-PN Latch release, 1 side with RJ45 civilian, cable RJ45FTP5E cat 5E, 2m long

► For specific cable harnesses, please consult us.

RES-SCE-8MG

Managed miniature portable Ethernet switch - 8 Gigabit ports

Military ethernet switch for harsh environment - Fully MIL-STD compliant

Amphenol's RES-SCE-8MG is a MIL-STD rugged, managed-military-grade Ethernet switch, offering 8 Gigabit Ethernet 10/100/1000 Ports. The portable rugged Ethernet switch is intended for unmanned vehicles or man packable command post.

Developed for SWaP (Size Weight and Power) and mobile portable military applications, the RES-SCE-8MG features mechanical packaging enhancements designed for MIL-STD-810F airborne and ground environmental compliance and high reliability. The unit has been especially hardened to improve ingress, impact, and shock/vibration protection, as well as eliminate all moving parts through passive cooling, and interface through sealed miniature circular connectors.

Leveraging best-in-class switching technology, the RES-SCE-8MG serves as a robust solution for providing local area network (LAN) connectivity to IP-enabled computing and net-centric devices. Compact in size, the RES-SCE-8MG is particularly useful for expanding port density in space-constrained airborne and ground vehicle environments.

Military applications

- Unmanned Vehicles
- Battlefield communication C4ISR
- Mobile communications
- Avionic & shipboard systems

Key features

- **Ethernet ports**
 - Managed 8 x switched 10/ 100/ 1000 ports
- **Networking**
 - Spanning Tree (802.1d), RSTP (802.1w) and multiple Spanning Tree (802.1S) for fast recovery rings
 - Security via Radius Authentication 802.1x, Port Security, Port Mirroring
 - Multicasting (IGMP Snooping), GARP, GMRP, and GVRP Broadcasting and flooding Control up to 8K Groups
 - 802.1q Tagged based VLAN up to 4K VLAN groups
 - QoS Multi-Layer Classifier, 802.1p, ToS/DSCP traffic classification. WFQ, Strict Queuing.
 - Bridge support for Q-in-Q
 - Link Aggregation 802.3AD
 - WEB, CLI, Telnet Management
- **Connectors**
 - Power connector type: SCE2-B-76A06-07SN
 - LAN connector type: SCE2-B-76A07-14SN-001
 - LED indication per port (speed, link/activity)
- **Chassis**
 - Low profile rugged aluminium extrusion
 - Conductively cooled w/ custom internal heat-sinks
 - Ingress protection against sand, dust and moisture
 - Epoxy-Polyamide Paint, Per MIL-C-83286, matt texture, color: Nato green
- **Standards**
 - MIL-STD-1275, MIL-STD-704A, MIL-STD-461E, MIL-STD-810F GM, IP67/68
- **Performance**
 - 26.8 Mpps wire speed forwarding rate
 - 20 Gbps maximum forwarding bandwidth
 - 8K MAC address
- **Activity status**
 - Indicators for Power and LAN activity (light off by default)
 - STATUS pushbutton to turn on the indicators



MILITARY RUGGED SWITCH
MIL-STD-1275B
MIL-STD-704A
MIL-STD-461E
MIL-STD-810F/GM
IP67

RESMLAC-8US-CAPS

Unmanaged military Ethernet switch, MIL-DTL-38999 connectors 8 fast ports

Military ethernet switch for harsh environment - Fully MIL-STD compliant

Amphenol's RESMLAC-8US-CAPS is a MIL-STD rugged, unmanaged-military-grade Ethernet switch, offering 8 Fast Ethernet 10/100 Ports.

Developed for military and harsh environment applications, the RESMLAC-8US-CAPS features mechanical packaging enhancements designed for MIL-STD-810F airborne and ground environmental compliance and high reliability. The unit has been especially hardened to improve ingress, impact, and shock/vibration protection, as well as eliminate all moving parts through passive cooling, and interface through sealed MIL-D-38999 circular connectors.

Leveraging best-in-class switching technology, the RESMLAC-8US-CAPS serves as a robust solution for providing local area network (LAN) connectivity to IP-enabled computing and net-centric devices. Compact in size, the RESMLAC-8US-CAPS is particularly useful for expanding port density in space-constrained airborne and ground vehicle environments.

Military applications

- Data acquisition & transmission
- Battlefield communication C4ISR
- Rugged Networks
- Mobile communications
- Combat vehicles
- Avionic & shipboard systems



Key features

- **Ethernet ports**
 - 8 x switched 10/100 (Fast Ethernet) ports
- **Networking**
 - Full wire-speed forwarding rate
 - Store-and-forward mechanism
 - Auto MDI-II, MDI-X
 - Auto-negotiation protocol
 - Address look-up
- **Connectors**
 - MIL-D-38999 (Power & Ethernet signals)
 - Power connector type: D38999/24WA98PA
 - LAN connector type: D38999/24WA35SN
- **Chassis**
 - Low profile rugged aluminium extrusion
 - Conductively cooled w/ custom internal heat-sinks
 - Ingress protection against sand, dust and moisture
 - Epoxy-Polyamide Paint, Per MIL-C-83286, matt texture, color: Nato green
- **Standards**
 - MIL-STD-1275, MIL-STD-704A, MIL-STD-461E, MIL-STD-810F GM, IP67/68
- **Voltage operation**
 - 24VDC (18VDC – 32VDC)



Product specifications

Performance

- 128K byte of SRAM for frame buffering
- 2.0 Gbps high-performance memory bandwidth
- 2 LED indication (speed, link/activity) per port
- Wire-speed reception and transmission
- Integrated address look-up engine
- Automatic address learning

Standards compliance

- IEEE 802.3 10 Mbps 10BASE-T (Ethernet)
- IEEE 802.3u 100BASE-TX 100 Mbps (Fast Ethernet)
- IEEE 802.3x flow control

Power

- MIL-STD-1275B & MIL-STD 704A surge and spike protection
- Voltage input: 24Vdc nominal (18-32V)
- Power consumption: 2.8W typical
- Chassis grounding

Electromagnetic

- MIL-STD-461E electromagnetic compatibility
- CE-102, CS-114, CS-115, CS-116, RE-102, RS-103

Environmental

- MIL-STD-810F, 501.4I, 501.4II, 502.4I, 502.4II, 507.4, 500.4II, 514, 516I, 516Vi, 514.5, 512.4
- IP67/68
- STANAG 4370, vibrations AECTP 400, method 401; cannon fire shocks, 6666 shocks up to 8.6g, half sine shape
- STANAG 2895, altitude 10.000m, temperature -21°C / 71°C

Physical

- Dimensions: 269mm(L) x 133(W) x 65(H), including connectors & hardware
- Weight: 1.5 kg

Installation

- Set of four 4x4.5 mounting holes on bottom for mounting to any flat surface.

Cooling

- No moving parts. Passive cooling.

Operating temp

- -35°C to +75°C (-31°F to +167°F) / -35°C Cold start-up

Storage temp

- -45°C to +85°C (-49°F to +185°F)

Dimensional line drawing

All measurements are in millimeters

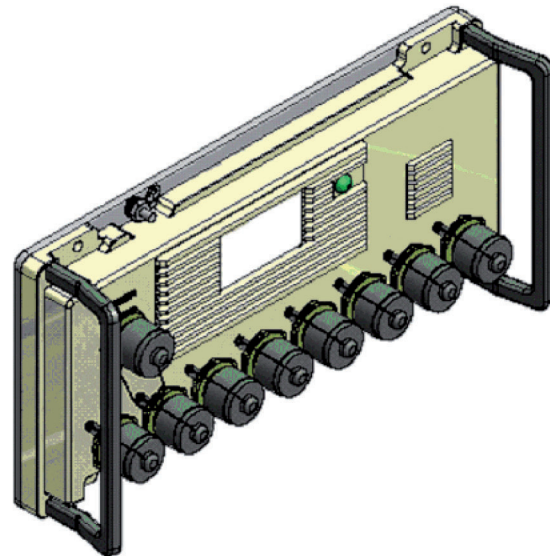
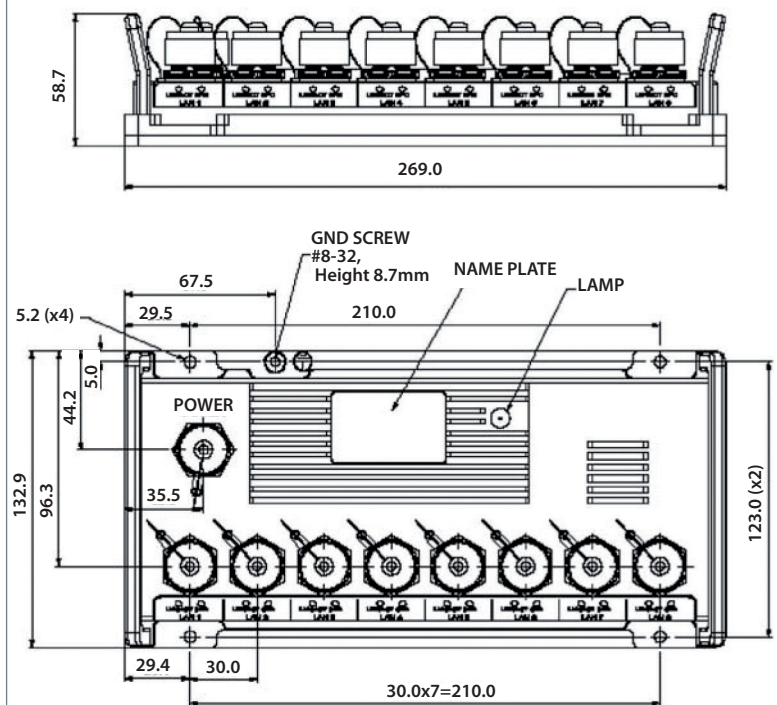

Part number code	Description
RESMLAC-8US-CAPS	MIL-STD Rugged Unmanaged Ethernet switch with 8 ports 10/100TX, color dark green
RESMLAC-8US-CAPS-SX	MIL-STD Rugged Unmanaged Ethernet switch with 8 ports 10/100TX, color black
RESMLAC-8US-CBL-PWR-2M	Power cordset for RESMLAC-8US-CAPS, 1 side with MIL-DTL-38999 plug, 1 side with 4mm plugs for power supply, cable 2m long
RESMLAC-8US-CBL-LAN-2M	LAN cordset for RESMLAC-8US-CAPS, valid for LAN 1 to 8, 1 side with MIL-DTL-38999 plug, 1 side with RJ45 civilian, cable RJFSFTP5E cat 5E, 2m long

► For specific cable harnesses, please consult us.

RJSMLAC-8UG-CAPS

Unmanaged military Ethernet switch, MIL-DTL-38999 connectors 8 Gigabit ports

Military ethernet switch for harsh environment - Fully MIL-STD compliant

Amphenol's RESMLAC-8UG-CAPS is a MIL-STD rugged, unmanaged-military-grade Ethernet switch, offering 8 triple speed Ethernet (10/100/1000) ports. Ethernet connectors are RJFTV, using RJField patented system that allows easy and quick assembly of any standard RJ45 cordset without any tool.

Developed for military and harsh environment applications, the RJSMLAC features mechanical packaging enhancements designed for MIL-STD-810F airborne and ground environmental compliance and high reliability. The unit has been especially hardened to improve ingress, impact, and shock/vibration protection, as well as eliminate all moving parts through passive cooling.

Leveraging best-in-class switching technology, the RJSMLAC serves as a robust solution for providing local area network (LAN) connectivity to IP-enabled computing and net-centric devices. Compact in size, the RJSMLAC is particularly useful for expanding port density in space-constrained airborne and ground vehicle environments.

Military applications

- Data acquisition & transmission
- Battlefield communication C4ISR
- Rugged Networks
- Mobile communications
- Combat vehicles
- Avionic & shipboard systems



Key features

- **Ethernet ports**
 - 8 x switched 10/100/1000 (Gigabit Ethernet) ports on RJFTV connectors
- **Networking**
 - Full wire-speed forwarding rate
 - Store-and-forward mechanism
 - Auto MDI-II, MDI-X
 - Auto-negotiation protocol
 - Address look-up
- **Connectors**
 - Power connector type: MIL-DTL-38999/24WA98PA
 - LAN connector type: RJFTV (coupling mechanism from MIL-DTL-38999)
 - LED indication per port (speed, link/activity)
- **Chassis**
 - Low profile rugged aluminium extrusion
 - Conductively cooled w/ custom internal heat-sinks
 - Ingress protection against sand, dust and moisture
 - Finish of epoxy-polyamide paint per MIL-C-83286, matt texture, color: Nato green
- **Standards**
 - MIL-STD-1275, MIL-STD-704A, MIL-STD-461E, MIL-STD-810F GM, IP67/68
- **Voltage operation**
 - 24VDC (18VDC – 32VDC)

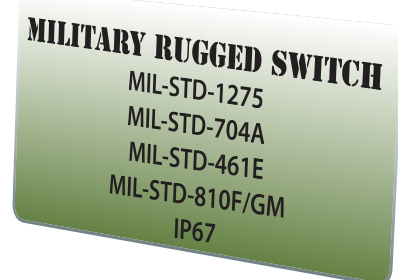

Product specifications

Performance

- 128K byte of SRAM for frame buffering
- 2.0 Gbps high-performance memory bandwidth
- 2 LED indication (speed, link/activity) per port
- Wire-speed reception and transmission
- Integrated address look-up engine
- Automatic address learning

Standards compliance

- IEEE 802.3 10BASE-T (Ethernet)
- IEEE 802.3u 100BASE-T (Fast Ethernet)
- IEEE 802.3ab 1000BASE-T (Gigabit Ethernet)
- IEEE 802.3x flow control

Power

- MIL-STD-1275B & MIL-STD 704A surge and spike protection
- Voltage input: 24Vdc nominal (18-32V)
- Power consumption: 7W typical
- Chassis grounding

Electromagnetic

- MIL-STD-461E electromagnetic compatibility
- CE-102, CS-114, CS-115, CS-116, RE-102, RS-103

Environmental

- MIL-STD-810F, 501.4I, 501.4II, 502.4I, 502.4II, 507.4, 500.4II, 514, 516I, 516Vi, 514.5, 512.4
- IP67/68

Physical

- Dimensions: 269mm(L) x 133(W) x 65(H), including connectors & hardware
- Weight: 1.8kg

Installation

- Set of four 4x4.5 mounting holes on bottom for mounting to any flat surface.

Cooling

- No moving parts. Passive cooling.

Operating temp

- -35°C to +75°C (-31°F to +167°F) / -35°C Cold start-up

Storage temp

- -45°C to +85°C (-49°F to +185°F)

Dimensional line drawing

All measurements are in millimeters

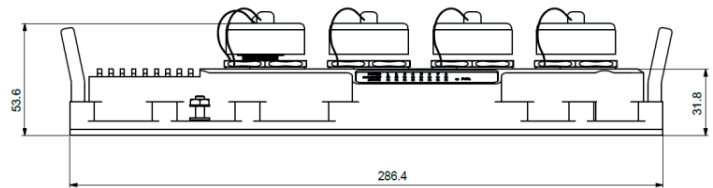
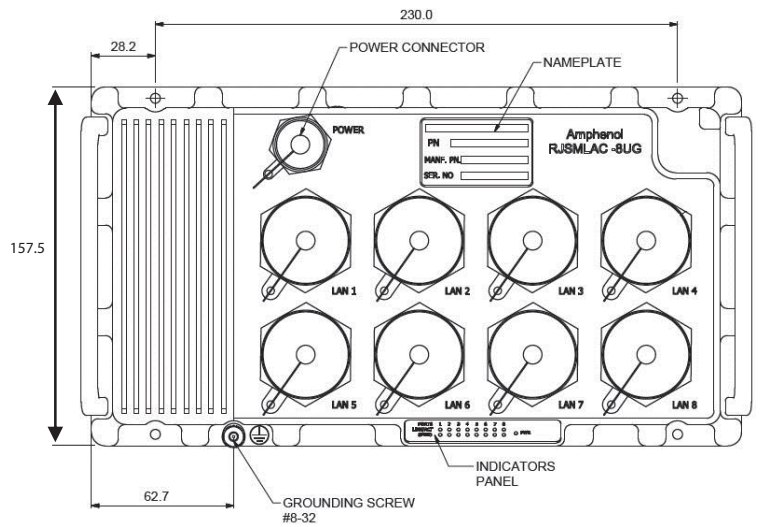

Part number code	Description
RJ5MLAC-8UG-CAPS	MIL-STD Rugged Unmanaged Ethernet switch with 8 ports 10/100/1000TX, powered with 18-32VDC
RJ5MLAC-8UG-CAPS-VAC	MIL-STD Rugged Unmanaged Ethernet switch with 8 ports 10/100/1000TX, powered with 90-265 VAC / 47-65 Hz
RJ5MLAC-8UG-CBL-PWR-2M	Power cordset for RJ5MLAC-8UG-CAPS, 1 side with MIL-DTL-38999 plug, 1 side with 4mm plugs for power supply, cable 2m long
RJ5MLAC-8UG-CBL-LAN-2M	LAN cordset for RJ5MLAC-8UG-CAPS, valid for LAN 1 to 8, 1 side with RJFTV6MG plug, 1 side with RJ45 civilian, cable RJFSFTP5E cat 5E, 2m long

► For specific cable harnesses, please consult us.

RJSMLAC-8MG-CAPS

Managed military Ethernet switch, RJFTV connectors - 8 Gigabit ports

Military ethernet switch for harsh environment - Fully MIL-STD compliant

Amphenol's RJSMLAC-8MG-CAPS is a MIL-STD Fully managed Military-grade network switch offering 8 triple speed (10/100/1000) ports. Ethernet connectors are RJFTV, using RJField patented system that allows easy and quick assembly of any standard RJ45 cordset without any tool.

Developed for military and harsh environment applications, the RJSMLAC-8MG-CAPS features mechanical packaging enhancements designed for MIL-STD-810F airborne and ground environmental compliance and high reliability. The unit has been especially hardened to improve ingress, impact, and shock/vibration protection, as well as eliminate all moving parts through passive cooling, and interface through sealed MIL-DTL-38999 circular connectors.

Leveraging best-in-class switching technology, the RJSMLAC-8MG-CAPS serves as a robust solution for providing local area network (LAN) connectivity to IP-enabled computing and net-centric devices. Compact in size, the RJSMLAC-8MG-CAPS is particularly useful for expanding port density in space-constrained airborne and ground vehicle environments.

Military applications

- Data acquisition & transmission
- Battlefield communication C4ISR
- Industrial Rugged Networks
- Mobile communications
- Combat vehicles
- Avionic & shipboard systems



Key features

- **Ethernet ports**
 - Managed 8 x switched 10/100/1000 ports on RJFTV connectors
- **Networking**
 - Spanning tree (802.1d), RSTP (802.1w) and multiple
 - Spanning tree (802.1S) for fast recovery rings
 - Security via Radius Authentication 802.1x, port security, port mirroring
 - Multicasting (IGMP Snooping), GARP, GMRP, and GVRP, Broadcasting and flooding control up to 8K groups.
 - 802.1q tagged based VLAN up to 4K VLAN groups.
 - QoS multi-layer classifier, 802.1p, ToS/DSCP traffic classification. WFQ, Strict Queuing.
 - Bridge support for Q-in-Q.
 - Link aggregation 802.3AD.
 - WEB, CLI, Telnet management.
- **Connectors**
 - Power connector type: MIL-DTL-38999/24WA98PA
 - LAN connector type: RJFTV (coupling mechanism from MIL-DTL-38999)
 - Management connector type: SCE2B 76 A 06 07 SN 001
 - LED indication per port (Speed, Link/Activity)
- **Chassis**
 - Low profile rugged aluminium extrusion
 - Conductively cooled w/custom internal heat-sinks
 - Ingress protection against sand, dust and moisture
 - Epoxy-Polyamide Paint, Per MIL-C-83286, matt texture, color: Nato green
- **Standards**
 - MIL-STD-1275, MIL-STD-704A, MIL-STD-461E,
 - MIL-STD-810F GM, IP67/68

MILITARY RUGGED SWITCH
MIL-STD-1275
MIL-STD-704A
MIL-STD-461E
MIL-STD-810F/GM
IP68
MIL-F-18870-E
MIL-STD-167-1A
MIL-S-901D

Product specifications

Voltage operation

- Standard model: 24VDC (18VDC ~ 32VDC)
- VAC model : 90-265 VAC / 47-65 Hz powered

Performance

- 26.8 Mpps wire speed forwarding rate
- 20 Gbps maximum forwarding bandwidth
- 8K MAC address

Standards compliance

- IEEE 802.1x MAC based authentication
- IEEE 802.1Q Vlan tagging
- IEEE 802.1P QoS
- IEEE 802.1S Multiple STP
- IEEE 802.1W Rapid STP
- IEEE 802.3AD Link aggregation

Power

- Exceed MIL-STD-1275B surge and spike protection
- Power consumption: 7W typical
- Chassis grounding

Electromagnetic

- MIL-STD-461E electromagnetic compatibility
- CE-102, CS-114, CS-115, CS-116, RE-102, RS-103

Environmental : shock/vibration/humidity

- MIL-STD-810F, 501.4I, 501.4II, 502.4I, 502.4II, 507.4, 500.4II, 514, 516I, 516VI, 514.5, 512.4
- IP67/68
- MIL-F-18870-E, Temperature shock test 72 hours @ -55°C, Storage
- MIL-STD-167-1A Low frequencies Vibrations
- MIL-S-901D Lightweight shocks

Physical

- Dimensions: 287mm(L) x 147(W) x 50(H), including connectors & hardware
- Weight: 1.8 kg

Installation

- Set of four 4.5 mounting holes on bottom for mounting to any flat surface.
- Carrying handles

Cooling

- No moving parts. Passive cooling.

Operating temp

- -35°C to +75°C (-31°F to +167°F) / -35°C Cold start-up

Storage temp

- -45°C to +85°C (-49°F to +185°F)

Dimensional line drawing

All measurements are in millimeters

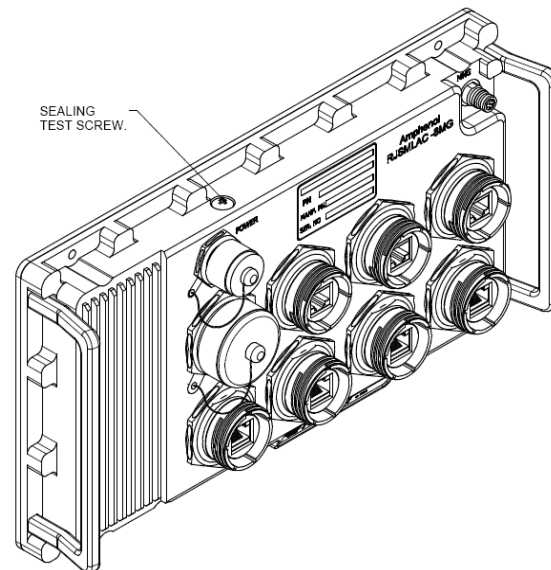
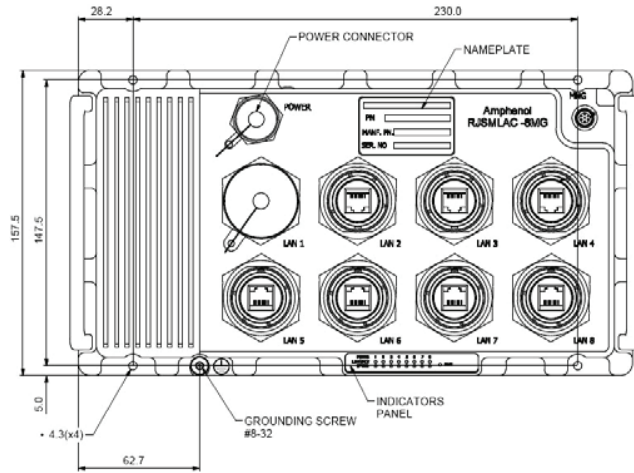
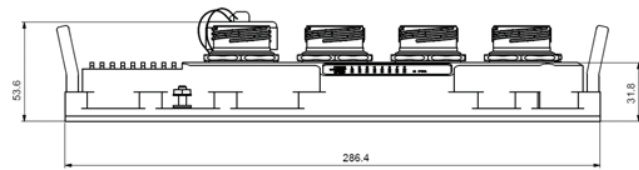

Part number code	Description
RJ5MLAC-8MG-CAPS	MIL-STD Rugged Managed Ethernet switch with 8 ports 10/100/1000TX, powered with 18-32VDC
RJ5MLAC-8MG-CAPS-VAC	MIL-STD Rugged Managed Ethernet switch with 8 ports 10/100/1000TX, powered with 90-265 VAC / 47-65 Hz
RJ5MLAC-8MG-CBL-PWR-2M	Power cordset for RJ5MLAC-8MG-CAPS, 1 side with MIL-DTL-38999 plug, 1 side with 4mm plugs for power supply, cable 2m long
RJ5MLAC-8MG-CBL-LAN-2M	LAN cordset for RJ5MLAC-8MG-CAPS, 1 side with RJFTV6MG plug, 1 side with RJ45 civilian, cable RJFSFTP5E cat 5E, 2m long
RJ5MLAC-8MG-CBL-MNG-2M	Management cordset for RJ5MLAC-8MG-CAPS, 1 side with SCE2BL1K0607PN plug, 1 side with DB-9 civilian, cable 2m long

► For specific cable harnesses, please consult us.

RESMLAC-8MG-CAPS

Managed military Ethernet switch, MIL-DTL-38999 connectors 8 Gigabit ports

Military ethernet switch for harsh environment - Fully MIL-STD-compliant

Amphenol's RESMLAC-8MG-CAPS is a MIL-STD fully managed Military-grade network switch offering 8 triple speed (10/100/1000) ports. Developed for military and harsh environment applications, the RESMLAC-8MG-CAPS features mechanical packaging enhancements designed for MIL-STD-810F airborne and ground environmental compliance and high reliability. The unit has been especially hardened to improve ingress, impact, and shock/vibration protection, as well as eliminate all moving parts through passive cooling, and interface through sealed MIL-DTL-38999 circular connectors.

Leveraging best-in-class switching technology from Amphenol, the RESMLAC-8MG-CAPS serves as a robust solution for providing local area network (LAN) connectivity to IP-enabled computing and net-centric devices. Compact in size, the RESMLAC-8MG-CAPS is particularly useful for expanding port density in space-constrained airborne and ground vehicle environments.

Military applications

- Data acquisition & transmission
- Battlefield communication C4ISR
- Rugged Networks
- Mobile communications
- Combat vehicles
- Avionic & shipboard systems



Key features

- **Ethernet ports**
 - Managed 8 x switched 10/100/1000 ports
- **Networking**
 - Spanning tree (802.1d), RSTP (802.1w) and multiple
 - Spanning tree (802.1S) for fast recovery rings
 - Security via Radius authentication 802.1x, port security, port mirroring
 - Multicasting (IGMP Snooping), GARP, GMRP, and GVRP, Broadcasting and flooding control up to 8K groups.
 - 802.1q tagged based VLAN up to 4K VLAN groups.
 - QoS multi-layer classifier, 802.1p, ToS/DSCP traffic classification. WFQ, Strict Queuing.
 - Bridge support for Q-in-Q.
 - Link aggregation 802.3AD.
 - WEB, CLI, Telnet management.
- **Connectors**
 - Power connector type: MIL-DTL-38999/24WA98PA
 - LAN connector type: MIL-D-38999/24WB35SN
 - LED indication per port (Speed, Link/Activity)
- **Chassis**
 - Low profile rugged aluminium extrusion
 - Conductively cooled w/custom internal heat-sinks
 - Ingress protection against sand, dust and moisture
 - Epoxy-Polyamide Paint, Per MIL-C-83286, semi-gloss
- **Standards**
 - MIL-STD-1275, MIL-STD-704A, MIL-STD-461E,
 - MIL-STD-810F GM, IP67/68
- **Voltage operation**
 - 24VDC (18VDC ~ 32VDC)

MILITARY RUGGED SWITCH
MIL-STD-1275
MIL-STD-704A
MIL-STD-461E
MIL-STD-810F/GM
IP67

Product specifications

Performance

- 26.8 Mpps wire speed forwarding rate
- 20 Gbps maximum forwarding bandwidth
- 8K MAC address

Standards compliance

- IEEE 802.1x MAC based authentication
- IEEE 802.1Q Vlan Tagging
- IEEE 802.1P QoS
- IEEE 802.1S Multiple STP
- IEEE 802.1W Rapid STP
- IEEE 802.3AD Link aggregation

Power

- Exceed MIL-STD-1275B surge and spike protection
- Voltage input: 24Vdc nominal (18-32V)
- Power consumption : 7W typical
- Chassis grounding

Electromagnetic

- MIL-STD-461E electromagnetic compatibility
- CE-102, CS-114, CS-115, CS-116, RE-102, RS-103

Environmental : shock/vibration/humidity

- MIL-STD-810F, 501.4I, 501.4II, 502.4I, 502.4II, 507.4, 500.4II, 514, 516I, 516VI, 514.5, 512.4
- IP67/68

Physical

- Dimensions: 269mm(L) x 133(W) x 79(H), including connectors & hardware
- Weight: 1.5 kg

Installation

- Set of four 4.5 mounting holes on bottom for mounting to any flat surface.
- Carrying handles

Cooling

- No moving parts. Passive cooling.

Operating temp

- -35°C to +75°C (-31°F to +167°F) / -35°C Cold start-up

Storage temp

- -45°C to +85°C (-49°F to +185°F)

Dimensional line drawing

All measurements are in millimeters

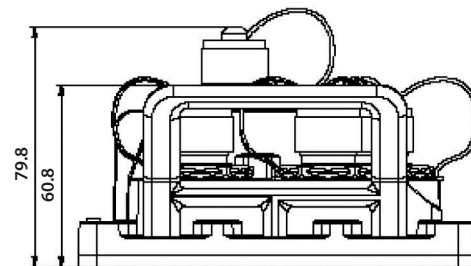
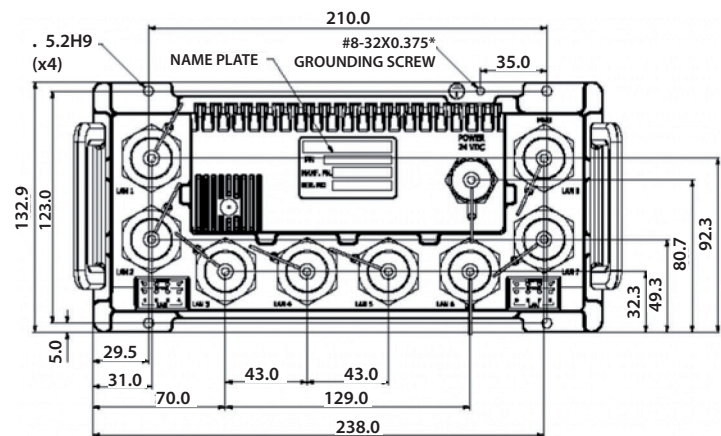
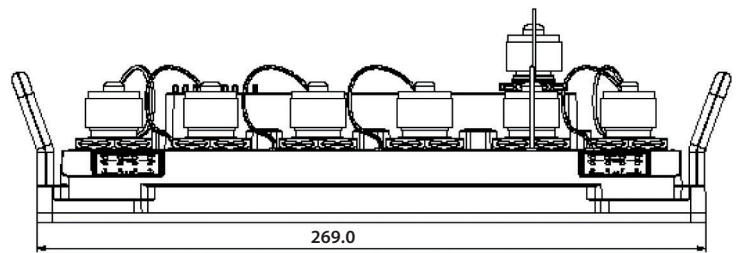

Part number code	Description
RESMLAC-8MG-CAPS	MIL-STD Rugged Managed Ethernet switch with 8 ports 10/100/1000TX, powered with 18-32VDC
RESMLAC-8MG-CBL-PWR-2M	Power cordset for RESMLAC-8MG-CAPS, 1 side with MIL-DTL-38999 plug, 1 side with 4mm plugs for power supply, cable 2m long
RESMLAC-8MG-CBL-LAN-2M	LAN cordset for RESMLAC-8MG-CAPS, 1 side with MIL-DTL-38999 plug, 1 side with RJ45 civilian, cable RJFSFTP5E cat 5E, 2m long
RESMLAC-8MG-CBL-MNG-2M	Management cordset for RESMLAC-8MG-CAPS, 1 side with MIL-DTL-38999 plug, 1 side with DB-9 civilian, cable 2m long

► For specific cable harnesses, please consult us.

RESMLAC-8MG-CAPS-F35

Managed military Ethernet switch, MIL-DTL-38999 connectors 8 Gigabit ports

Military ethernet switch for harsh environment - Fully MIL-STD-compliant

Amphenol's RESMLAC 8MG CAPS F35 is a MIL-STD fully managed Military-grade network switch offering 8 triple speed (10/100/1000) ports.

Developed for military and harsh avionic applications, the RESMLAC 8MG CAPS F35 features mechanical packaging enhancements designed for MIL-STD-810F airborne and ground environmental compliance and high reliability. The unit has been especially hardened to improve ingress, impact, and shock/vibration protection, as well as eliminate all moving parts through passive cooling, and interface through sealed MIL-DTL-38999 circular connectors.

Leveraging best-in-class switching technology from Amphenol, the RESMLAC 8MG CAPS F35 serves as a robust COTS solution for providing local area network (LAN) connectivity to IP-enabled computing and net-centric devices. Compact in size, the RESMLAC 8MG CAPS F35 is particularly useful for expanding port density to tactical IP routers in space-constrained airborne and ground vehicle environments.

Military applications

- Data acquisition & transmission
- Battlefield communication C4ISR
- Rugged Networks
- Mobile communications
- Combat vehicles
- Avionic & shipboard systems

Key features

- **Ethernet ports**
 - Managed 8 x switched 10/100/1000 ports
- **Networking**
 - Spanning tree (802.1d), RSTP (802.1w) and multiple
 - Spanning tree (802.1S) for fast recovery rings
 - Security via Radius authentication 802.1x, port mirroring
 - Multicasting (IGMP Snooping), GARP, GMRP, and GVRP, Broadcasting and flooding control up to 8K groups.
 - 802.1q tagged based VLAN up to 4K VLAN groups.
 - QoS multi-layer classifier, 802.1p, ToS/DSCP traffic classification. WFQ, Strict Queuing.
 - Bridge support for Q-in-Q.
 - Link aggregation 802.3AD.
 - WEB, CLI, Telnet management.
- **Connectors**
 - Power connector type: MIL-DTL-38999/24WB35PN
 - LAN connector type: MIL-D-38999/24WF35PN
 - LED indication per port (Speed, Link/Activity)
- **Chassis**
 - Low profile rugged aluminium extrusion
 - Conductively cooled w/custom internal heat-sinks
 - Ingress protection against sand, dust and moisture
 - Epoxy-Polyamide Paint, Per MIL-C-83286, semi-gloss
- **Standards**
 - MIL-STD-1275B, MIL-STD-704A, MIL-STD-461A,
 - MIL-STD-810F GM, IP67/68
- **Voltage operation**
 - Nominal 24VDC

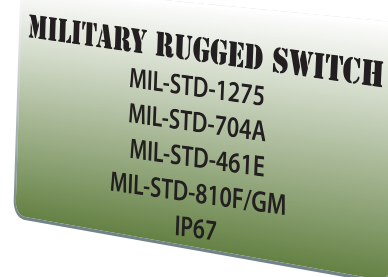

Product specifications

Performance

- 26.8 Mpps wire speed forwarding rate
- 20 Gbps maximum forwarding bandwidth
- 8K MAC address

Standards compliance

- IEEE 802.1x MAC based authentication
- IEEE 802.1Q Vlan Tagging
- IEEE 802.1P QoS
- IEEE 802.1S Multiple STP
- IEEE 802.1W Rapid STP
- IEEE 802.3AD Link aggregation

Power

- Exceed MIL-STD-1275B surge and spike protection
- Voltage input: 24Vdc nominal (18-32V)
- Power consumption : 7W typical
- Chassis grounding

Electromagnetic

- Exceed MIL-STD-461A electromagnetic compatibility
- RE-02, RS-03

Environmental : shock/vibration/humidity

- MIL-STD-810F, 501.4I, 501.4II, 502.4I, 502.4II, 507.4, 500.4II, 514, 516I, 516VI, 514.5, 512.4

Physical

- Dimensions: 209.6mm(L) x 136(W) x 44.4(H), including connectors
- Weight: 1.1 kg

Installation

- Set of four #10-32 captive screws for mounting to any flat surface

Cooling

- No moving parts. Passive cooling.

Operating temp

- -35°C to +75°C (-31°F to +167°F) / -35°C Cold start-up

Storage temp

- -45°C to +85°C (-49°F to +185°F)

Dimensional line drawing

All measurements are in millimeters

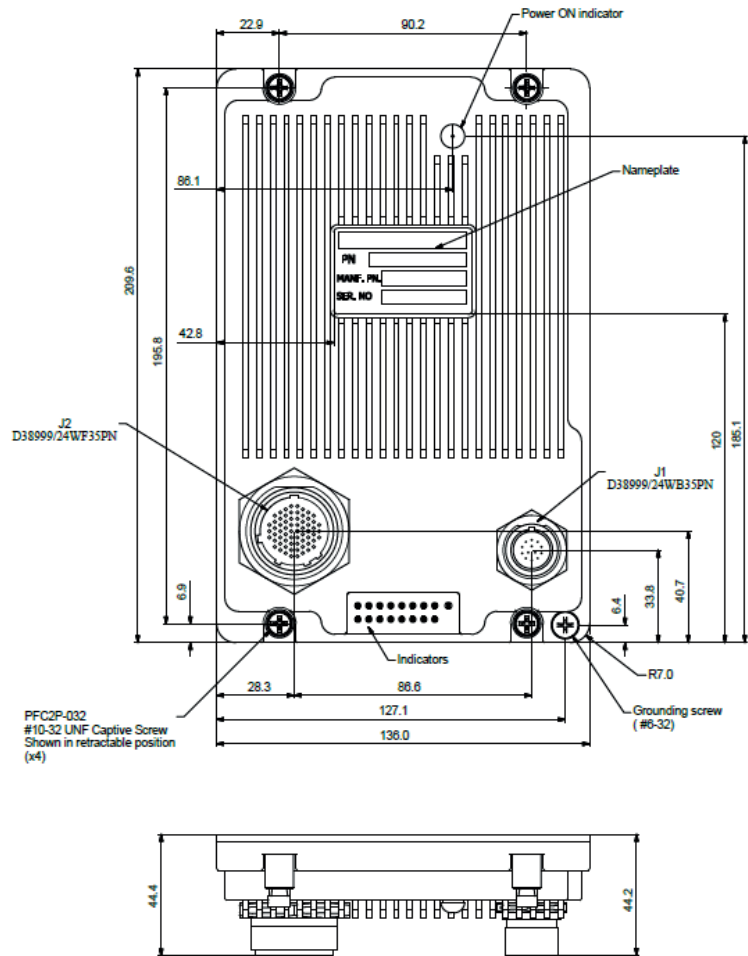

Part number code	Description
RESMLAC-8MG-CAPS-F35	MIL-STD Rugged Managed Ethernet switch with 8 ports 10/100/1000TX, powered with 18-32VDC
RESMLAC-F35-CBL-PWR-2M	Power cordset for RESMLAC-8MG-CAPS-F35, 1 side with MIL-DTL-38999 plug, 1 side with 4mm plugs for power supply, cable 2m long

► For specific cable harnesses, please consult us.

RESMLAC-28MG

Managed military Ethernet switch - 24 Gigabit + 4 combo 10G ports

Military ethernet switch for harsh environment - Fully MIL-STD compliant

The RESMLAC-28MG is a MIL-STD Fully managed Military-grade network switch offering 24 triple speed (10/100/1000) ports + 4 x 10G fiber ports.

The RESMLAC-28MG is compatible with all the newest military industry network protocols for redundant link topology, security, multi-cast and management requirements.

Developed specifically for military and harsh mobile applications, the RESMLAC-28MG features mechanical packaging enhancements designed for MIL-STD-810F airborne and ground environmental compliance and high reliability. The unit has been especially hardened to improve ingress, impact, and shock/vibration protection, as well as eliminate all moving parts through passive cooling, and interface through sealed MIL-D-38999 circular connectors and SCE.

Leveraging best-in-class switching technology, the RESMLAC-28MG serves as a robust COTS solution for providing local area network (LAN) connectivity to IP-enabled computing and net-centric devices. Compact in size, the RESMLAC-28MG is particularly useful for expanding port density to tactical IP routers in space-constrained airborne and ground vehicle environments.

Military applications

- Data acquisition & transmission
- Battlefield communication C4ISR
- Rugged Networks
- Mobile communications
- Combat vehicles
- Avionic & shipboard systems



Features

■ Ethernet ports

- Managed 24 x switched 10/100/1000 ports (including 4 Combo ports) + 4x10Gbps Fiber ports - Total of 28 ports.
- The 4 Combo ports provide alternative 4 ports 100/1000Base-FX ports

■ Networking

General

- Wire-speed hardware-based 28 ports gigabit ethernet switch
- Multicasting (IGMP Snooping), GARP, GMRP, MLD and GVRP
- Multicast groups up to 8K for both IPv4 and IPv6
- Broadcasting and flooding control up to 8K groups
- 802.1q tagged based VLAN up to 4K VLAN groups
- Link Aggregation 802.3ad, up to 16 members in group
- Link Aggregation mechanism based on L2/ L3/ L4 parameters
- Jumbo Frame support up to 10K
- WEB, CLI, Telnet Management

Quality of service

- QoS Multi-Layer Classifier: 802.1p, EtherType, VLAN-ID, IPv4/ 6 DSCP/ ToS, and UDP/TCP ports & ranges traffic classification
- Per port WFQ and Strict Queuing scheduling
- DSCP remarking for both IPv4 and IPv6 frames
- Ingress policer and ingress shaper per port with 500Kbps granularity
- Egress shaper per port with 500Kbps granularity
- Full-duplex flow control (IEEE802.3X) and half-duplex backpressure, symmetric and asymmetric.

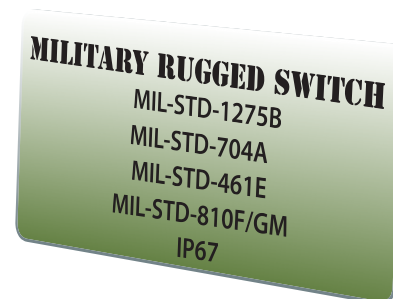

...

Security

- Security via Radius authentication 802.1x, Port/MAC access control
- Port security
- Per port ingress and egress port mirroring
- Mirroring per VLAN and per content awareness match
- Private VLAN support per VLAN (Isolated and Promiscuous ports)
- Content Aware Policers:
 - 128 Content Aware Policers
 - 16 Content Aware rate policers with rates from 1fps to 32 million fps
 - 8 UDP/TCP port range policers
 - Advanced ACL through hardware based match patterns
 - Content Aware Policers for generic MAC, ARP, IPv4, IPv6 protocols
 - No restriction on any mix of entries to Content Aware Policers
 - Content Aware Policers actions are permit/deny, police, count, snoop and mirror
 - Special support for IP fragments, UDP/TCP port ranges and ARP
 - Extensive CPU DoS prevention
 - Surveillance functions by Content Aware Policers counters
 - Multiple ACLs per port for optimal usage of Content Aware Policers
- Storm controllers for flooded broadcast, multicast and unicast

Redundancy and ring protection

- Spanning tree (802.1d), RSTP (802.1w) and multiple Spanning tree (802.1s) for fast recovery rings
- RPR for up to 30 units per ring with recovery time <50ms hardware based
- RPR for up to 30 units per ring with recovery time <50ms hardware
- 20-Gbps bandwidth for ring topology
- QoS consistency across stack / ring
- Mirroring across stack / ring
- Link aggregation groups spanning multiple switches in stack/ring

Connectors

- 2 x Power connector type: MIL-DTL-38999/24WC4P (1 optional)
- 24 x LAN connector type: SCE2-B-76A07-14SN-001 (4 ports are Gigabit Combo ports - 10/100/1000 or 1000FX fiber)
- Optional fiber optic connectors: TVOP (MIL-D-38999), or CTOS (STANAG 4290), or TACBEAM (M83526/20&21)
- 1 x Serial interface, shared with LAN port #1
- LED indication per Port (Speed, Link/Activity) per Unit (Power A, Power B)

Dimensional line drawing

All measurements are in millimeters

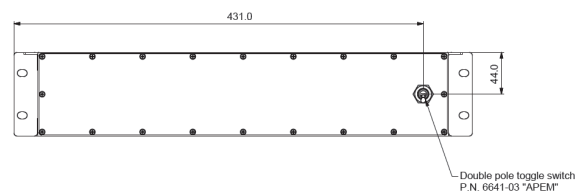
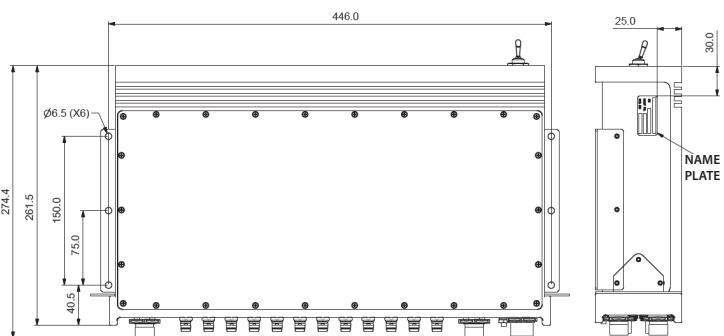
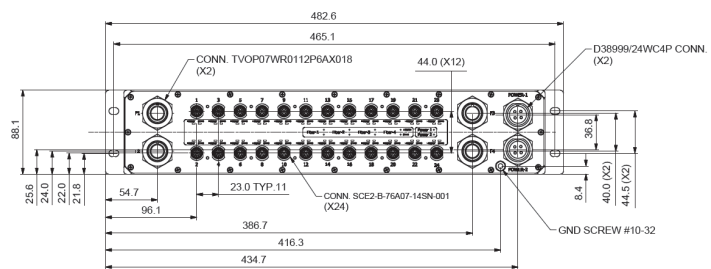

■ Chassis

- Low profile rugged aluminium extrusion
- Conductively cooled w/custom internal heat-sinks
- Ingress protection against sand, dust and moisture
- Epoxy-Polyamide Paint, Per MIL-C-83286, semi-gloss

■ Standards

- MIL-STD-1275B, MIL-STD-704A, MIL-STD-461E, MIL-STD-810F GM, IP67
- Support up to 50ms holdup time, and 6VDC drops

■ Performance

- 96.8 Mbps wire speed forwarding rate
- 56 Gbps maximum forwarding bandwidth
- 8K MAC address

■ Power

- Exceed MIL-STD-1275B and MIL-STD-704A Surge and Spike protection with 50ms holdup time and 6VDC drops
- Voltage input:
 - VDC versions: 24VDC nominal (18-32VDC)
 - VAC versions: 90-265 VAC / 47-65 Hz
- Power consumption: 20W typical
- Chassis grounding

■ Electromagnetic

- MIL-STD-461E Electromagnetic compatibility
- CE-102, CS-114, CS-115, CS-116, RE-102, RS-103

■ Shock / Vibration / Humidity

- MIL-STD-810F, 501.4I, 501.4II, 502.4I, 502.4II, 507.4, 500.4II, 514, 516I, 516VI, 514.5, 512.4

■ Physical

- Dimensions: 440mm (L) x 200mm (W) x 88(H), including connectors & hardware, 2U, 19" rack
- Weight: 5.6 kg

■ Installation

- Set of four 4.5mm mounting holes on bottom for mounting to any flat surface
- 19" standard mounting ears

■ Cooling

- No moving parts. Passive cooling.

■ Operating temp

- -35°C to +75°C (-31°F to +167°F) / -35°C cold start-up

■ Storage temp

- -45°C to +85°C (-49°F to +185°F)

Part number code

	RESMLAC-28MG	-	M	TVOP	10G	DC
Fiber optic ports						
(empty)	No fiber optic ports					
2	2 fiber optic ports					
4	4 fiber optic ports					
Type of fiber optic						
M	Multimode fiber optic, 2 ways, 50/125µm					
S	Singlemode fiber optic, 2 ways, 9/125µm					
WDM	WDM Singlemode fiber optic, 1 single way (10G only), 9/125µm					
Fiber optic connectors						
TVOP	TVOP connector with butt joint, MIL-D-38999					
CTOS	CTOS connector with expanded beam, for intensive use in harsh environments, STANAG 4290					
TACB	TACBEAM connector with expanded beam, M83526/20&21					
Datarate for fiber optic ports						
G	1000 Mbps					
10G	10G					
Voltage input						
DC	Unit powered with 18-36VDC					
VAC	Unit powered with 90-265 VAC / 47-65 Hz					

Part number code

Description

Part number code	Description
RESMLAC-28MG-CBL-PWR-2M	Power cordset for RESMLAC-28MG, 1 side with MIL-DTL-38999 plug, 1 side with 4mm plugs for power supply, cable 2m long
RESMLAC-28MG-CBL-MNG-2M	Management Cordset for RESMLAC-28MG, SCE2B-L1K-0714PN on one side, DB-9 female plug on the other side, length 2m
RESMLAC-28MG-CBL-LAN-2M	LAN Cordset for RESMLAC-28MG, 1 termination with SCE2B-L1K-0714PN, 1 termination with RJ45, RJFSFTP5E cat 5E cable 2m

► **For specific cable harnesses, please consult us.**

RJSML-8US1 & RJSML-8UG1

Unmanaged military Ethernet switch - Fast or Gigabit

Military ethernet switch for harsh environment with industrial EMI compliancy

Sealed, rugged & unmanaged switch

Amphenol offers an unmanaged Ethernet switch with 8 gigabit ports RJSML-8UG1.

The switch can withstand a variety of extreme conditions. Whatever the situation - high temperatures, extreme shocks & vibrations, dust particles or even liquid immersion- there is a solution available.

The switch electronics are sealed within a waterproof IP68 metallic enclosure.

The conductive cadmium plating is suitable for most demanding EMI-RFI environments. Black paint is also offered when RoHS is required (other colors available).

The I/O interface includes redundant power inputs as well as waterproof rugged RJ45 connectors from the RJFTV FIELD threaded product series based on MIL-DTL-38999 (Series III) metallic shell size 19. This serie enables the transformation without tooling of any standard RJ45 cordset into a robust and waterproof connection system.

Military applications

- Battlefield communication C4ISR
- Rugged Networks
- Mobile communications
- Avionic & shipboard systems

Key features

- **Rugged environmental feature**
 - Rugged metal packaging with cadmium or paint protection
 - Mil-DTL-38999 III connectors for both power and Ethernet ports
 - IP65/IP68 rated when mated
 - Power filtering and protection (-704 option)
 - MIL-STD-461E (CE03) 600V spike suppressor
 - MIL-STD-704A
 - MIL-STD-1275A
 - RT CA/DO-160B
 - MIL-STD-810F shocks
 - RTCA/DO-160C Vibrations
 - Full-Duplex operation with flow control (no collisions!)
 - MIL STD 810F altitude 50,000 ft (15,000 m)
 - Auto-detecting, auto-crossover and auto-polarity
 - Broadcast storm protection
- **Models 8US1**
 - 8 ports 10/100-BaseT(X)
 - Wide operating temperature range of -40°C to 70°C
- **Models 8UG1**
 - 8 ports 10/100/1000-BaseT(X)
 - Wide operating temperature range of -10°C to 60°C
 - Supports Jumbo frame transmission up to 9kbytes
- **Models 8UG1-ET**
 - 8 ports 10/100/1000-BaseT(X)
 - Wide operating temperature range of -40°C to 70°C
 - Supports Jumbo frame transmission up to 9kbytes



IEEE Ethernet standards

Models	Features	802.3/u	802.3x	802.3ab
RJS XX 8US1 XX	Unmanaged - Fast	●	●	X
RJS XX 8UG1 XX	Unmanaged - Gigabit	●	●	●
IEEE 802.3/u	10 Mbps & 100 Mbps fast Ethernet			
IEEE 802.3x	Full-Duplex with flow control			
IEEE 802.3ab	1000 Mbps Gigabit Ethernet			

Ethernet features

RJ45 Ports	8 shielded RJ45 ports 10/100 BaseT(X) or 1000 Base T(X)
Connectors for RJ45 ports	RJFTV: jam nut receptacle based on MIL-DTL-38999 III Olive drab cadmium or nickel plated
RJ45 speed	10, 100 or 1000 Mbps auto -negotiation
Full / Half duplex	Automatic
MDI/MDIX	Auto-crossover

Environmental specifications

Safety	UL 60950-1, CAN/CSA-C22.2 No.60950
EMI emissions	U.S.A.: FCC Part 15 CISPR 22 U.E. EN55011, EN61000-6-4, EN55022 Class A, EN61000-3-2/3, EN55024, IEC61000-4-2/3/4/5/6/8, EN61000-6-2
Shocks	MIL-STD-810F: 40g, 11 ms, 18 saw tooth shocks
Vibrations	RTCA/DO-160C sinusoidal vibrations 5-55 Hz: 0.01 inch; 55-500 Hz : 1.5 g
Altitude	MIL-STD-810F: 50.000 ft - 15.000 m
Temperature	Operating models 8UG1: -10°C to +60°C models 8US1: -40°C to +70°C models 8UG1-ET: -40°C to +70°C Storage all models: -40°C to +85°C

Weight approx 2.8 kg

Power supply

Input voltage	8US1, 8UG1, & 8UG1-ET: 12-48 VDC, redundant power input (P1 and P2) 8US1-704 & 8UG1-704: 12-33 VDC, single power input (P1 only) 8US1-PSM & 8UG1-PSM: 85-264 VAC single power input
Input power	5 W max
Connectors for power	MIL-DTL-38999 III jam nut receptacle, olive drab cadmium or nickel plated 1 connector TVx07xx0935P: 6 cts # 22D (wire 0.38 mm ² maxi) 1 connector TVx07xx0935PA (for PSM option)
"OK" contact output	Sourcing power ; maximum current: 1 A @ 24VDC Not available for -704 and -PSM options

Additional power protection for models MG7F3G-704 (option-704)

MIL-STD-461E	CE102 conducted emission
DEF-STAN-59-41	DCE01/DCE02
DEF-STAN-61-5	Pt 6
MIL-STD-704A	600V input transient, applied for 10us
MIL-STD-1275A	Spikes: +/- 250 V for 100us Surges: 100 V for 50 ms at 0.5 mohm Ripple: 14VAC pk-pk

Description

- 1 IP68 aluminium enclosure with cadmium conductive plating or black paint (RoHS)
- 2 Redundant power inputs
- 3 Balance pressure vent
- 4 8 rugged IP68 RJ45 Ethernet ports
- 5 Fixture for vertical mounting

Optional caps available

IMPORTANT NOTE

This model has no LED indicator.



Description (in mm)

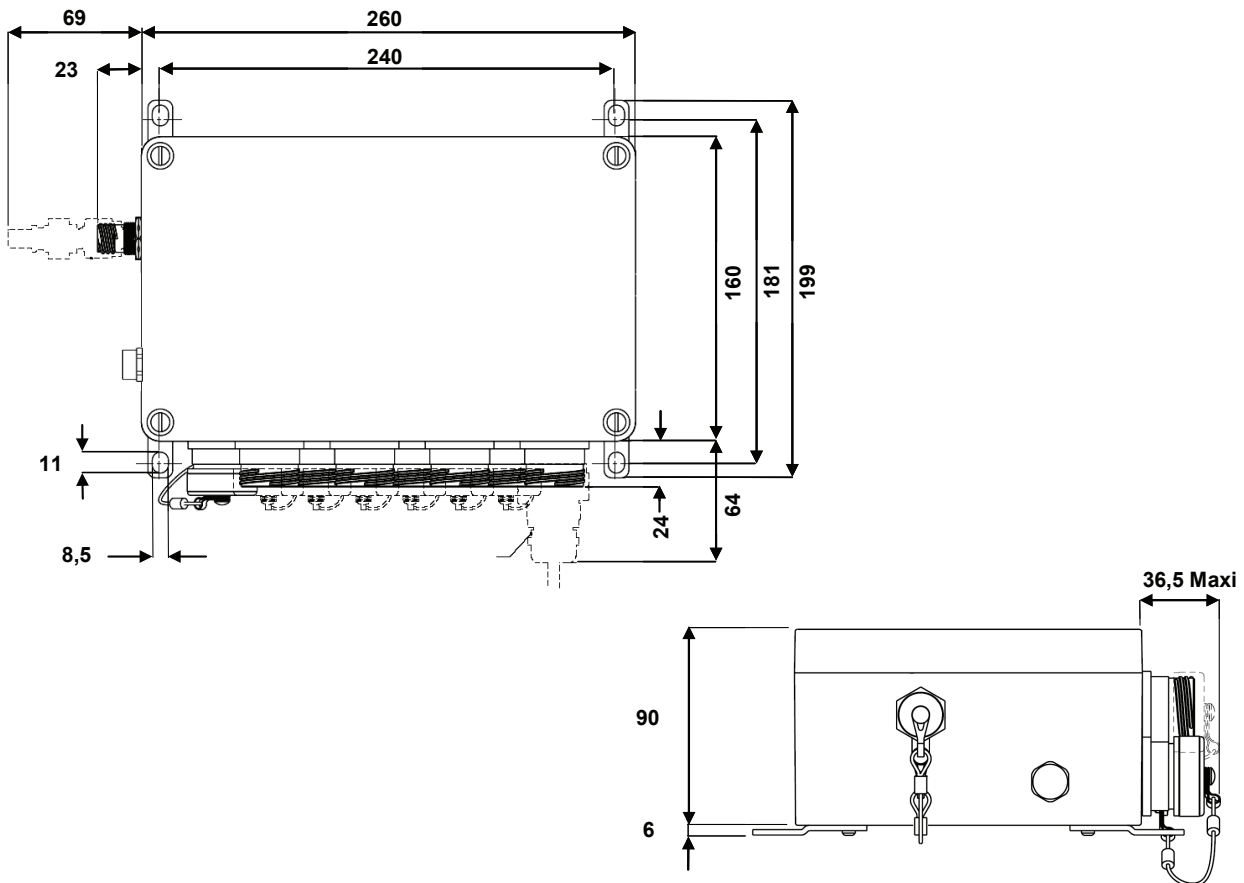

Pin-out for the power connector

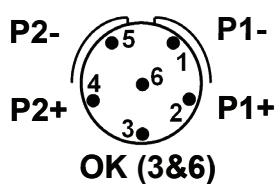

8US1, 8UG1, & 8UG1-ET
P1 and/or P2: 12-48 VDC

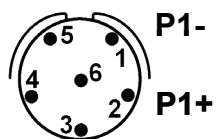

P1: 12-33VDC
3, 4, 5, 6: not connected

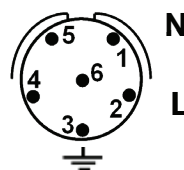

L: 85-264 VAC
4, 5, 6: not connected

Part number code

Series	RJS	ML	8US1	-	-	-
Type of Enclosure						
ML: MIL-DTL-38999 (series III) Receptacles, OD Cadmium Plating						
BKN: RAL 9005 (Jet black) Paint on Aluminium box, Nickel plated 38999 (series III) Receptacles, ROHS compliant						
Type of Electronics						
8US1: unmanaged 8 ports 10/100 Base T(X), wide temperature range						
8UG1: unmanaged 8 ports 10/100/1000 Base T(X)						
8UG1-ET: unmanaged 8 ports 10/100/1000 Base T(X), wide temperature range						
Optional: transient suppression module; 600V spike suppressor						
(Blank): no transient suppression module						
704: switch equipped with additional transient suppression module						
Optional: AC power supply						
(Blank): DC powered						
PSM: switch powered with 85-264 VAC instead of DC power						
Optional: Caps for receptacles fixed with cord directly to the receptacle						
(Blank): no caps included. The Ethernet ports are still sealed but the contacts are not protected.						
CAPS: attached caps for both power and data included						

Example: RJS ML 8UG1 704 CAPS: unmanaged switch in an aluminum enclosure with olive drab green conductive cadmium plating, 8 gigabit ports, RJFTV threaded coupling receptacles, additional transient suppression module, caps are added to the switch

Remark: All BKN Ethernet switches and nickel plated accessories are RoHs compliant.
 -704- and -PSM- options can not be selected together.
 With the -704- option, a filter module is included inside the switch allowing to meet MIL-STD-461 and other aircraft standards.
 With the -CAPS- option, all the receptacles come pre-equipped with a cap.

Accessories

Plugs for Ethernet ports
 RJF TV 6 M G: cadmium OD plating
 RJF TV 6 M N: nickel plating
 Based on MIL-DTL-38999
 No tool required !!!



Caps for Ethernet ports
 RJSML C7G: cadmium OD plating
 RJSML C7N: nickel plating
 A simple screwdriver is needed!



Plugs for I/O ports:
 MIL-DTL-38999,
 cadmium plated, crimp contacts
 Two plugs (6 cts # 22D)
 TV 06 RW 0935 S: cadmium OD plating
 TV S06 RF 0935 S: nickel plating



Backshells for I/O plugs
 We suggest to use MIL-DTL-38999 III backshells.
 Consult the dedicated catalog (E118) for details.
 Examples:
 TVNSA 09 014 : shielding backshell, cadmium OD plating
 TVNSA 09 023: shielding backshell, nickel plating
 + 804221 straight heat shrink for sealing



Example: RJS ML 8UG1 704 CAPS

with an RJSML 8UG1 704 CAPS switch, we suggest to use hereafter accessories:
 RJF TV 6 M G (up to 8) for Ethernet ports
 TV 06 RW 0935 S + TVNSA 09 014 + 804221 for power port

RJSML-8MF

Managed military Ethernet switch - Fast

Military Ethernet switch for harsh environment with industrial EMI compliancy

Sealed, rugged & managed switch

Amphenol offers a managed Ethernet switch with 8 fast ports RJSML-8MF1.

The switch can withstand a variety of extreme conditions. Whatever the situation - high temperatures, extreme shocks & vibrations, dust particles or even liquid immersion- there is a solution available.

The switch electronics are sealed within a waterproof IP68 metallic enclosure.

The conductive cadmium plating is suitable for most demanding EMI-RFI environments. Black paint is also offered when RoHS is required (other colors available).

The I/O interface includes redundant power inputs as well as waterproof rugged RJ45 connectors from the RJFTV FIELD threaded product series based on MIL-DTL-38999 (Series III) metallic shell size 19. This series enables the transformation without tooling of any standard RJ45 cordset into a robust and waterproof connection system.

Military applications

- Data Acquisition & Transmission
- Battlefield communication C4ISR
- Rugged Networks
- Mobile communications
- Test Equipment

Key features

- 8 Fast Ethernet (10/100 Mbps) ports
- Rugged environmental feature
 - Rugged metal packaging with cadmium or paint protection
 - MIL-DTL-38999 III connectors for power
 - MIL-DTL-38999 III RJFTV connectors for Ethernet ports
 - IP65/IP68 rated when mated
- Power filtering and protection (-704 option only)
 - MIL-STD-461E (CE03) 600V spike suppression
 - MIL-STD-704A
 - MIL-STD-1275A
 - RTCA/DO-160B
- MIL-STD-810F shocks
- RTCA/DO-160C Vibrations
- Wide operating temperature range of -40°C to +70°C
- MIL-STD-810F Altitude 50,000 ft (15,000 m)

Ethernet features

- Full-Duplex operation with flow control (no collisions!)
- Auto-detecting, auto-crossover and auto polarity
- RSTP redundant rings, Couple rings
- QoS and CoS priority queuing
- SNMP v1/V2C authentication
- IGMP for multicast filtering
- VLAN for traffic segregation
- And much more!



IEEE Ethernet standards

- IEEE 802.3/u 10 Mbps & 100 Mbps Fast Ethernet
- IEEE 802.1p Priority queuing - QoS, CoS, ToS/DS
- IEEE 802.3x Full-Duplex with Flow Control
- IEEE 802.1D/w Rapid Spanning Tree for redundant rings
- IEEE 802.1Q VLAN for traffic segregation

Ethernet features

- RJ45 Ports 8 shields RJ45 ports 10/100 BaseT(X)
- Connectors for RJ45 ports RJFTV: jam nut receptacle based on MIL-DTL-38999 III
Olive drab cadmium or Nickel plated
- RJ45 speed 10 or 100 Mbps auto –negotiation
- Full / Half Duplex Automatic or Configurable
- RJ45 MDI/MDIX Auto-crossover
- RJ45 TD and RD polarity Auto-polarity
- Memory bandwidth 1.6 Gbps (backplane)
- Ethernet isolation 1500 Vrms 1 minute
- Ring features Advantech X-Ring Pro, Dual Homing, Couple Ring

Environmental specifications

- EMI emissions EN55022 class A, FCC part 15, IC ES-003
- EMC immunity EN 61000-4-2
EN 61000-4-3
EN 61000-4-4
EN 61000-4-5
EN 61000-4-6
EN 61000-4-8
- Shocks MIL-STD-810F: 40g, 11ms, 18 saw tooth shocks
- Vibrations RTCA/DO-160C Sinusoidal vibrations 5-55 Hz: 0.01 inch ; 55-500 Hz: 1.5 g
- Altitude MIL-STD-810F: 50,000 ft - 15,000 m
- Temperature Operating -40°C to +70°C
Storage -40°C to +85°C

Weight

Approx 2.8 kg

Power supply

- Input voltage 8MF1 12-48 VDC, redundant power input (P1 and P2)
8MF1-704 12-33 VDC, single power input (P1 only)
8MF1-PSM 85-264 VAC single power input
- Input power 7.6 W max
- Connectors for power MIL-DTL-38999 III jam nut receptacle, olive drab cadmium or nickel
1 connector TVx07xx0935P: 6 cts # 22D (wire 0.38 mm² maxi)
- "OK" contact output Sourcing power ; Maximum current: 1 A @ 24VDC
Not available for -704 and -PSM options

Additional power protection for models 8MF1-704 (option-704)

- MIL-STD-461E CE102 Conducted emission
- DEF-STAN-59-41 DCE01/DCE02
- DEF-STAN-61-5 Pt 6
- MIL-STD-704A 600V input transient, applied for 10us
- MIL-STD-1275A Spikes: +/- 250 V for 100us
Surges: 100 V for 50 ms at 0.5 mohm
Ripple: 14VAC pk-pk

Description

- ① IP68 Aluminum enclosure
- ② Redundant power inputs
- ③ Balance pressure vent
- ④ 8 Rugged IP68 RJ45 Ethernet ports
- ⑤ Fixture for vertical mounting
- ⑥ Optional caps available



IMPORTANT NOTE

This model has no LED indicator.
Management is done through a web browser

Dimensions (in mm)

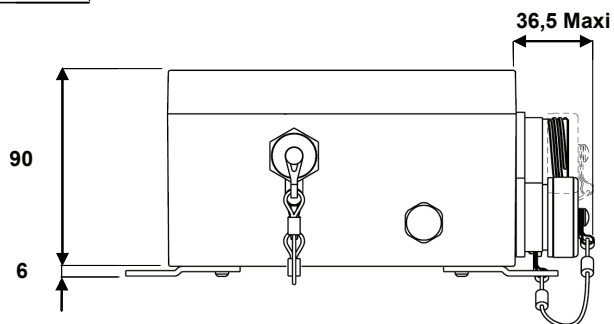
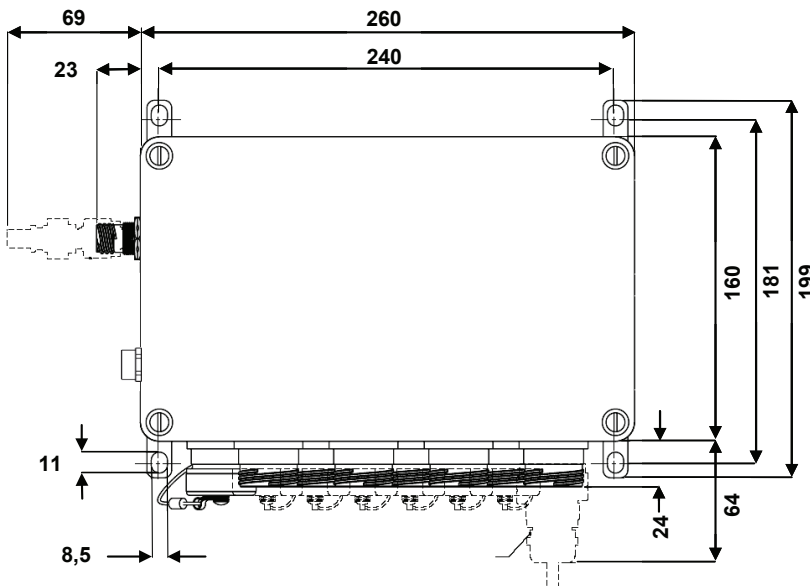

Pin-out for the power connector

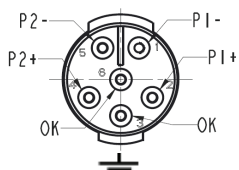

P1 and/or P2: 12-48VDC

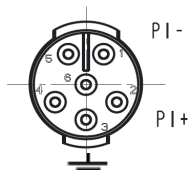

P1: 12-48VDC
3, 4, 5, 6: Not connected

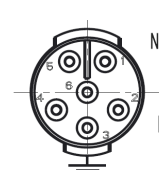

L: 85-264 VAC
4, 5, 6: Not connected

Part number code

Series	RJS	ML	8MF1	-	-	CAPS
Protection and color ML: Olive Drab Cadmium Plating on enclosure and receptacles BKN: RAL 9005 (Jet Black) Paint on enclosure, Nickel plated receptacles, ROHS compliant ML1019: RAL 1019 (Sand) Paint on enclosure, Olive Drab Cadmium plated receptacles BKN9010: RAL 9010 (White) Paint on enclosure, Nickel plated receptacles, ROHS compliant						
Type of Electronics 8MF1: managed 8 ports 10/100 BaseT(X) Ethernet switch Optional: transient suppression module; 600V spike suppressor (Blank): no transient suppression module (standard model) 704: switch equipped with additional transient suppression module						
Optional: AC power supply (Blank): (standard model) PSM: switch powered with 85-264 VAC instead of DC power						
Optional: Caps for receptacles fixed with cord directly to the receptacle (Blank): no caps included. The Ethernet ports are still sealed but the contacts are not protected. Caps can be ordered separately. CAPS: attached caps for both power and Ethernet ports included (standard model)						

Example: RJS ML 8MF1 CAPS Managed Ethernet switch in an aluminum enclosure with olive drab green conductive cadmium plating over enclosure and receptacles, 8 ports 10/100 BaseT(X) RJFTV threaded coupling receptacles, caps screwed to the switch.

Remark:

All BKN and BKN9010 switches and nickel plated accessories are RoHS compliant.
 704 and PSM options can not be selected together.
 With the -704 option, a filter module is included inside the switch allowing to meet MIL-STD-461 and other airborne standards.
 With the -CAPS option, all the receptacles comes pre-equipped with a cap.

Accessories

Plugs for Ethernet ports
 RJF TV 6 M G: cadmium OD plating
 RJF TV 6 M N: nickel plating
 Based on MIL-DTL-38999
 No tool required !!!



Caps for Ethernet ports
 RJSML C7G: cadmium OD plating
 RJSML C7N: Nickel plating
 A simple screwdriver is needed!



Plugs for I/O ports
 MIL-DTL-38999,
 cadmium plated, crimp contacts
 two plugs (6cts # 22D)
 TV 06 RW 0935 S: cadmium OD plating
 TV S06 RF 0935 S: nickel plating



Backshells for I/O plugs
 We suggest to use MIL-DTL-38999 III
 backshells
 Consult the dedicated catalog (E118) for
 details



Examples:
 TVNSA 09 014: shielding backshell, cadmium OD plating
 TVNSA 09 023: shielding backshell, nickel plating + 804221 straight heat
 shrink for sealing

Example: RJS ML 8MF1 CAPS With a RJSML 8MF1 CAPS Ethernet switch, we suggest to use hereafter accessories:
 RJF TV 6 MG (up to 8) for Ethernet ports
 TV 06 RW 0935S + TVNSA 09 014 + 804221 heatshrink for power ports

RJSML-MG7F3G

Managed military Ethernet switch - 7 fast ports + 3 Gigabit ports

Military ethernet switch for harsh environment with industrial EMI compliancy

Sealed, rugged & managed switch

Amphenol offers a 10 ports managed Ethernet switch RJSML-MG-7F3G.

Note: this model replaces the RJSML-9MG1 and the RJSML-9RG1.

The switch can withstand a variety of extreme conditions: whatever the situation - high temperatures, extreme shocks and vibrations, dust particles or even liquid immersion there is a solution available.

The switch electronics are sealed within a waterproof IP68 metallic enclosure.

The conductive cadmium plating is suitable for most demanding EMI-RFI environments. Black paint is also offered when RoHs is required (others colors available).

The I/O interface includes redundant power inputs as well as waterproof rugged RJ45 connectors from the RJF TV FIELD threaded product series based on MIL-DTL-38999 (Series III) metallic shell size 19.

This serie enables the transformation without tooling of any standard RJ45 cordset into a robust and waterproof connection system.

Military applications

- Data acquisition & transmission
- Battlefield communication C4ISR
- Rugged Networks
- Mobile communications
- Test equipment
- Avionic & shipboard systems

Key features

- **Rugged environmental feature**
 - Rugged metal packaging with cadmium or paint protection
 - Mil-DTL-38999 III connectors for both power and Ethernet ports
 - IP65/IP68 rated when mated
 - Power filtering and protection (-704 option)
 - MIL-STD-461E (CE03) 600V spike suppressior
 - MIL-STD-704A
 - MIL-STD-1275A
 - RTCA/DO-160B
 - MIL-STD-810F shocks
 - RTCA/DO- 160C Vibrations
 - Wide operating temperature range of -40°C to 70°C
 - MIL-STD-810F Altitude 50,000 ft 15,000 m
- **Ethernet features**
 - 3 ports 10/100/1000-BaseT(X) + 7 ports 10/100-BaseT(X)
 - Full-Duplex operation with flow control (no collisions!)
 - Auto-detecting, auto-crossover and auto-polarity
 - MIL-STD-810F shocks
 - RSTP for redundant rings
 - QoS and CoS priority queuing
 - SNMPv3 authentication and encryption
 - IGMP for multicast filtering
 - VLAN for traffic segregation
 - And much more !



IEEE Ethernet standards

Models	Features	802.3/u	802.3x	802.3z	802.1p	802.1D	802.1w	802.1Q
RJS XX MG 7F3G XX	Managed - Gigabit	●	●	●	●	●	●	●
IEEE 802.3/u	10 Mbps & 100 Mbps fast Ethernet			IEEE 802.1p	Priority queuing - QoS, CoS, ToS/DS			
IEEE 802.3x	Full-Duplex with flow control			IEEE 802.1D/w	Rapid spanning tree for redundant rings			
IEEE 802.3ab	1000 Mbps Gigabit Ethernet			IEEE 802.1Q	VLAN for traffic segregation			

Ethernet features

RJ45 ports	10 shields RJ45 ports 10/100 BaseT(X) or 1000 Base T(X)
Connectors for RJ45 ports	RJFTV: jam nut receptacle based on MIL-DTL-38999 III Olive drab cadmium or Nickel plated
RJ45 speed	10 or 100 Mbps auto -negotiation
Typical latency	16 us + frame time @ 10 Mbps (varies on load and settings) 5 us + frame time @ 100 Mbps
Full / Half Duplex	Automatic or configurable
RJ45 MDI/MDIX	Auto-crossover
RJ45 TD and RD polarity	Auto-polarity
MAC addresses supported	8192
Memory bandwidth	32 Gbps (gigabit) ; 3.2 Gbps for all other models
Ring features	Link loss recovery time: 30 ms plus 5 ms per hop
<i>(for Ring model only)</i>	Maximum switches in ring: 50+ Dual Ring support

Environmental specifications

EMI emissions	EN55022 class A, FCC part 15, IC ES-003
EMC immunity	IEC61326-1, IEEE C37.90
Shocks	MIL-STD-810F: 40g, 11ms, 18 saw tooth shocks
Vibrations	RTCA/DO-160C sinusoidal vibrations 5-55 Hz: 0.01 inch ; 55-500 Hz: 1.5 g
Altitude	MIL-STD-810F: 50.000 ft - 15.000 m
Temperature	Operating -40°C to +70°C Storage -40°C to +85°C

Weight approx 2.8 kg

Power supply

Input voltage	MG7F3G: 10-30 VDC, redundant power input (P1 and P2) MG7F3G-704: 10-30 VDC, single power input (P1 only) MG7F3G-PSM: single power input AC or DC <ul style="list-style-type: none"> - AC voltage: 85-264 VAC/Frequency 47-63 Hz - DC voltage: 120-370 VDC
Input power	5 W typical (all ports active)
Connectors for power	MIL-DTL-38999 III jam nut receptacle, olive drab cadmium or nickel plated 1 connector TVx07xx0935P: 6 cts # 22D (wire 0.4 mm ² maxi)
"OK" contact output	Sourcing power ; Maximum current : 0.5 A MG7F3G: ON if P1 and P2 have power and switch software is running MG7F3G-704: ON when software is running MG7F3G-PSM: ON when software is running; output power: 24VDC

Additional power protection for models MG7F3G-704 (option-704)

MIL-STD-461E	CE102 Conducted emission
DEF-STAN-59-41	DCE01/DCE02
DEF-STAN-61-5	Pt 6
MIL-STD-704A	600V input transient, applied for 10us
MIL-STD-1275A	Spikes: +/- 250 V for 100us Surges: 100 V for 50 ms at 0.5 mohm Ripple: 14VAC pk-pk

Description

- 1 IP68 aluminium enclosure with cadmium conductive plating or black paint (RoHS)
- 2 Redundant power inputs
- 3 Balance pressure vent
- 4 10 rugged IP68 RJ45 Ethernet ports
- 5 Fixture for vertical mounting
- 6 Optional caps available

IMPORTANT NOTE

This model has no LED indicator.
Management is done through a web browser

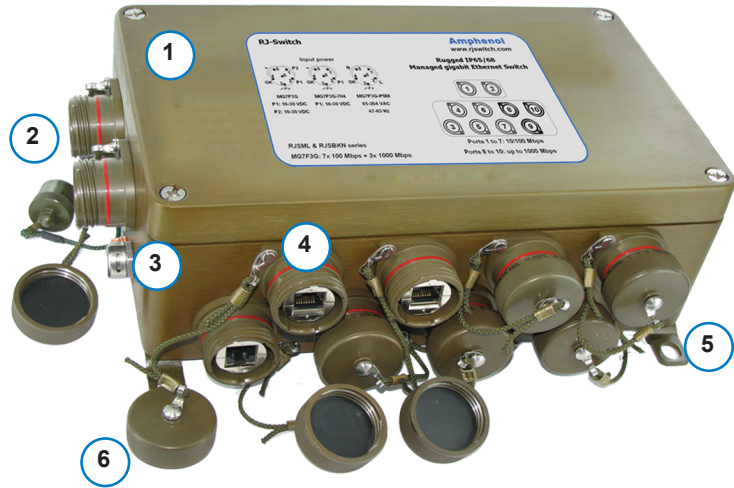

Description (in mm)

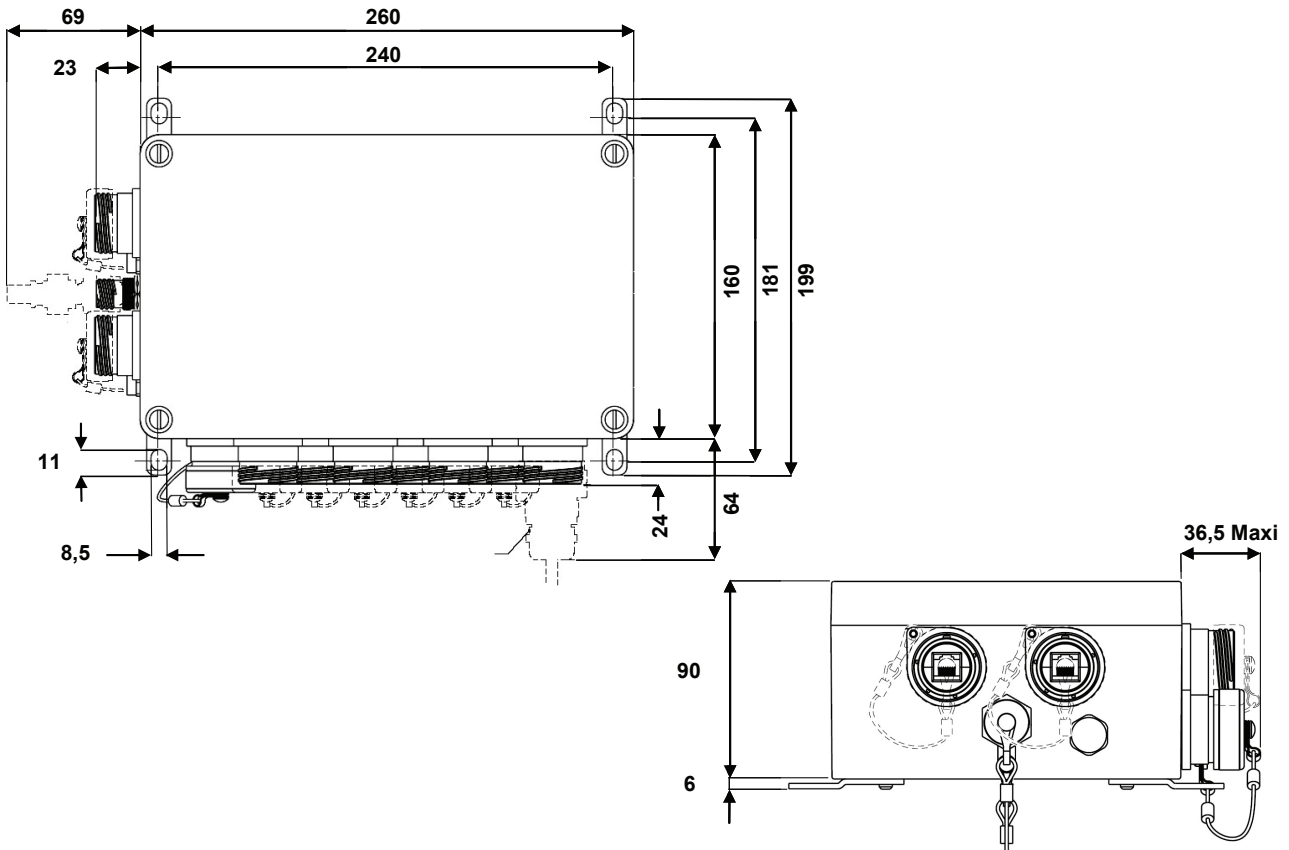

Pin-out for the power connector

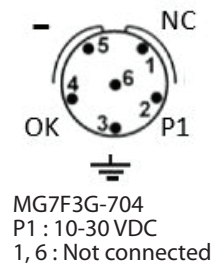
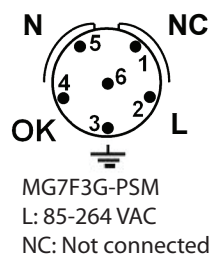
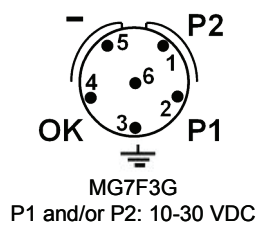

Part number code

Series	RJS	ML	MG7F3G	-	-	-
Type of Enclosure ML: MIL-DTL-38999 (series III) receptacles, OD Cadmium plating BKN: RAL 9005 (jet black) paint on aluminium box, nickel plated 38999 (series III) receptacles, ROHS compliant						
Type of Electronics MG7F3G: managed 7 ports 10/100 Base T(X) + 3 ports 10/100/1000 BaseT(X)						
Optional: transient suppression module; 600V spike suppressor (Blank): no transient suppression module 704: switch equipped with additional transient suppression module						
Optional: AC power supply (Blank): DC powered PSM: switch powered with 85-264 VAC instead of DC power						
Optional: Caps for receptacles fixed with cord directly to the receptacle (Blank): no caps included. The Ethernet ports are still sealed but the contacts are not protected. CAPS: attached caps for both power and data included						

Example: RJS ML MG7F3G 704 CAPS Managed switch in an aluminium enclosure with olive drab green conductive cadmium plating, 7 ports 10/100 Base T(X) + 3 gigabit ports, RJF TV threaded coupling receptacles, additional transient suppression module, caps are added to the switch.

Remark: All BKN Ethernet switches and nickel plated accessories are RoHs compliants.
 704 and PSM options can not be selected together.
 With the -704 option, a filter module is included inside the switch allowing to meet MIL-STD-461 and other aircraft stan dards.
 With the -CAPS option, all the receptacles comes pre-equipped with a cap.

Accessories

Plugs for Ethernet ports
 RJF TV 6 M G: cadmium OD plating
 RJF TV 6 M N: nickel plating
 Based on MIL-DTL-38999
 No tool required !!!



Caps for Ethernet ports
 RJSML C7G: cadmium OD plating
 RJSML C7N: Nickel plating
 A simple screwdriver is needed!



Plugs for I/O ports:
 MIL-DTL-38999,
 cadmium plated, crimp contacts
 Two plugs (6 cts # 22D)
 TV 06 RW 0935 S: cadmium OD plating
 TV S06 RF 0935 S: nickel plating

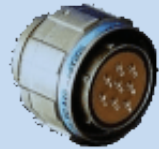

Backshells for I/O plugs
 We suggest to use MIL-DTL-38999 III backshells.
 Consult the dedicated catalog (E118) for details.
 Examples:
 TVNSA 09 014 : shielding backshell,
 cadmium OD plating
 TVNSA 09 023: shielding backshell, nickel plating
 + 804221 straight heat shrink for sealing



Example: RJS ML MG7F3G 704 CAPS With a RJSML MG7F3G 704 CAPS switch, we suggest to use hereafter accessories :
 RJF TV 6 M G (up to 10) for Ethernet ports
 TV 06 RW 0935S + TVNSA 09 014 + 804221 for power ports