



X30 SHIFTER 125cc

**ASSEMBLY
INSTRUCTIONS
AND USER MANUAL**

MAN-081

FEEDING

Fuel mixture **98RON** and **4% oil** (CIK homologated)

Our experience dictates use of oils, such as:

- WLADOIL K 2T;
- ELF HTX 909;
- ELF HTX 976;
- SHELL ADVANCE RACING M.

GEARBOX LUBRIFICATION



ATTENTION: *the engine is supplied without oil in the gearbox.*

GEARBOX OIL CHARGING

Before using, fill with approx. 350ml, through the charging hole. **(A)**. Oil with specification **SAE 75W** or **SAE 75W90** or **SAE 10W50**.

In order to check the prescribed correct quantity of oil in the crankcase, unscrew the screw **(V)** from the engine as shown in the picture, if the oil slightly flows out, the quantity is correct.

A complete oil change is recommended after **20 hours** of operation (**non-competition use**) and **8÷10 hours** in competition use.

GEARBOX OIL DISCHARGING

Remove the drain plug **(B)** to discharge oil, inspect the magnet in the plug to check the eventual presence of consistent metallic particles.

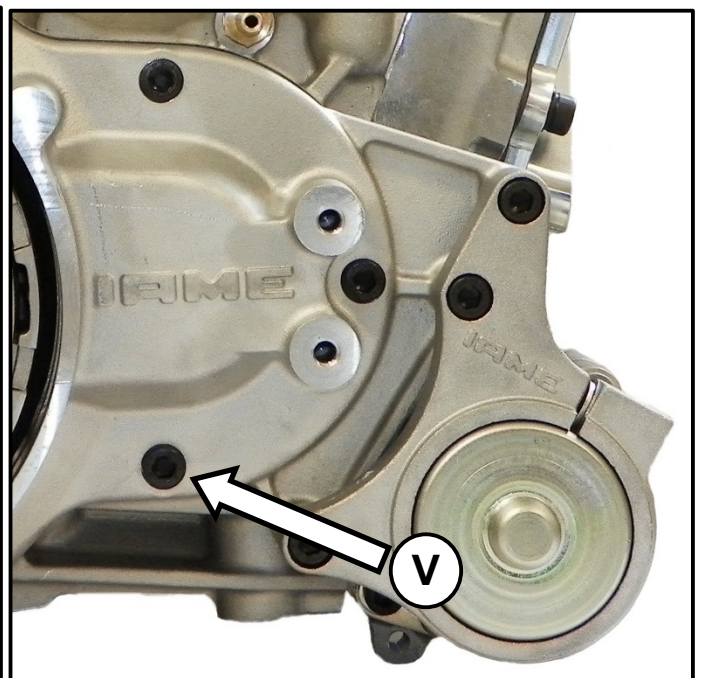
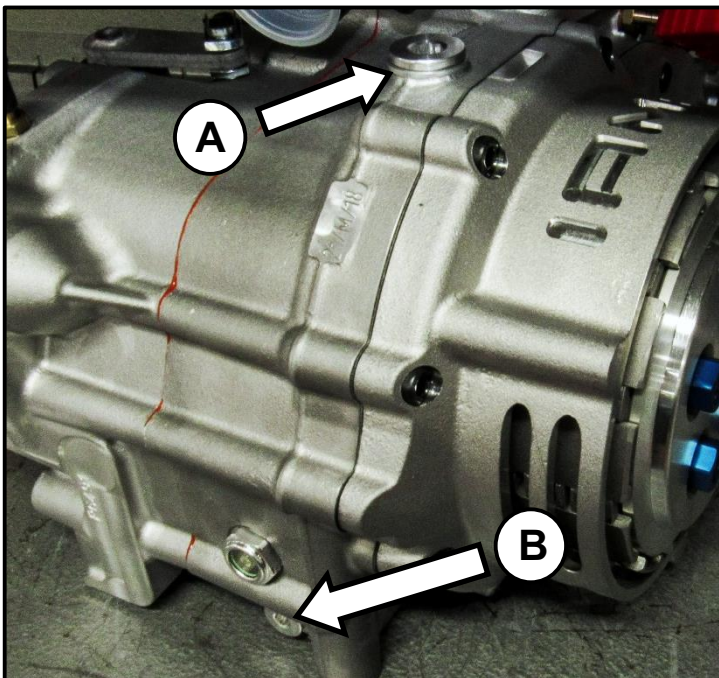

COOLING SYSTEM CONNECTIONS

CONNECT THE SYSTEM AS SHOWN IN FIGURE

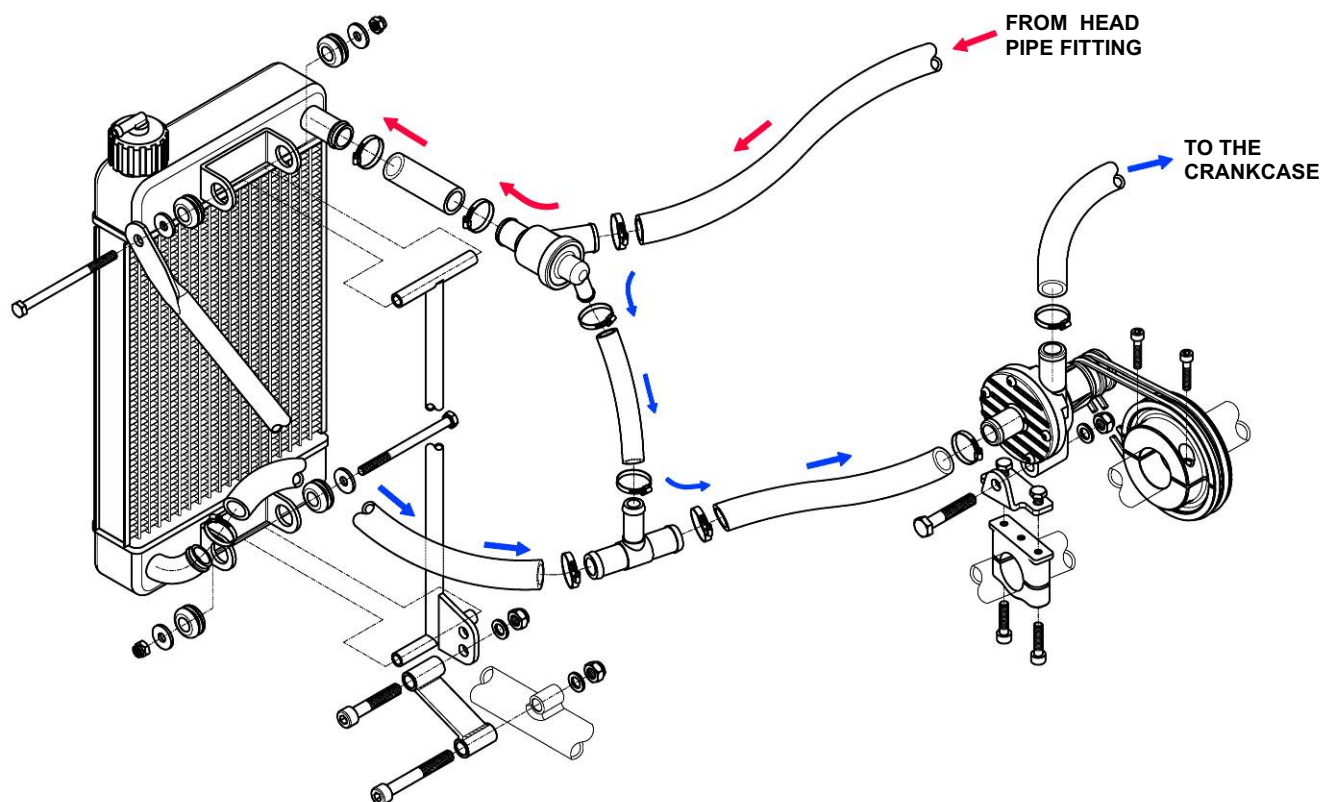

Once the system is filled (with pure water), provide to the proper air venting. We recommend the use of a 3 way-thermostat (opening temperature $48^{\circ}\text{C}\pm 2$), as shown on the drawing, especially during the wintertime.

It is though possible to make a direct connection, removing the thermostat, the T-pipe and the bypass-tube between them.

The presence of the thermostat doesn't eliminate the need for adequate partialization of the radiant surface and for protective spoilers on the cylinder during the cold season (temperature $\leq 5^{\circ}\text{C}$).



ATTENTION: water cooling operation temperature
limits: min. 50°C / max. 58°C

ELECTRIC SYSTEM

ELECTRIC CONNECTIONS 2016

The engine is provided with an digital ignition with variable advance.
When the piston is at T.D.C. the notches of the rotor and stator coincide.

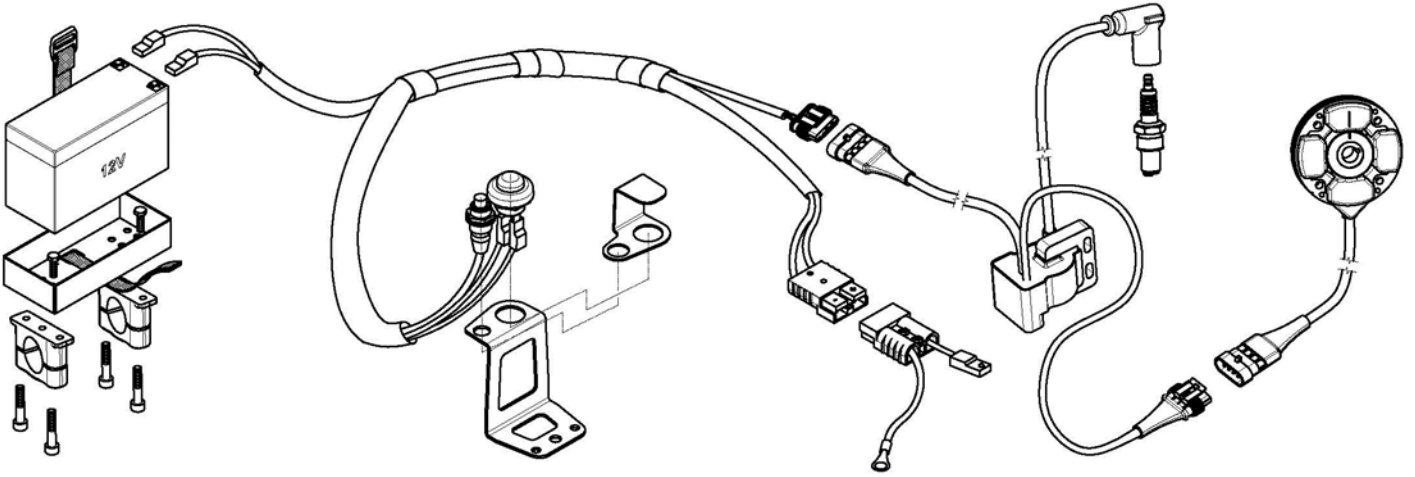

***ATTENTION: VERY IMPORTANT IS TO CONNECT
THE COPPER WIRE TO ENGINE AND COIL'S BODY***

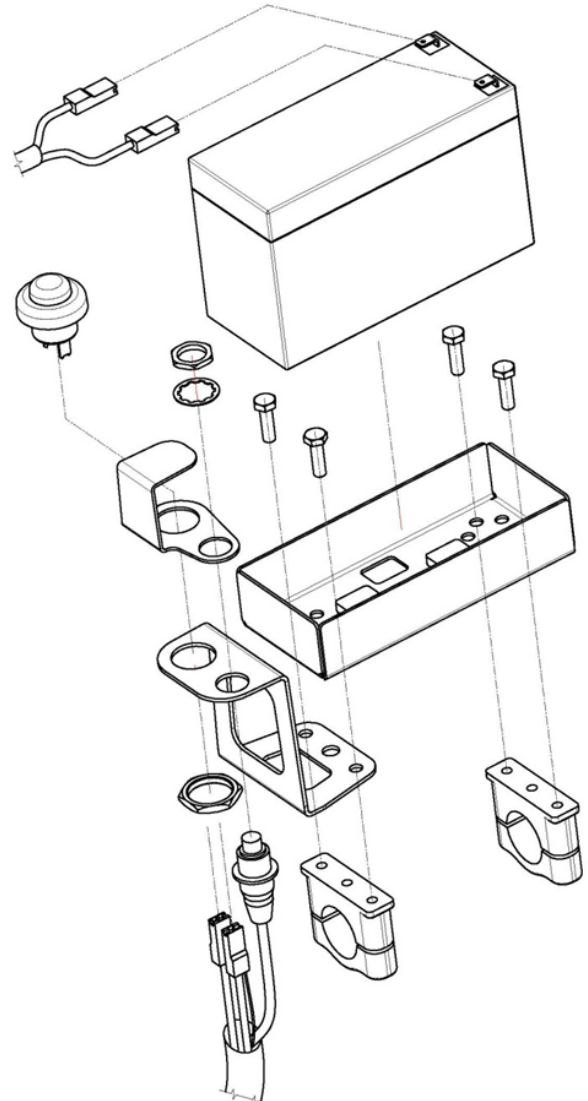
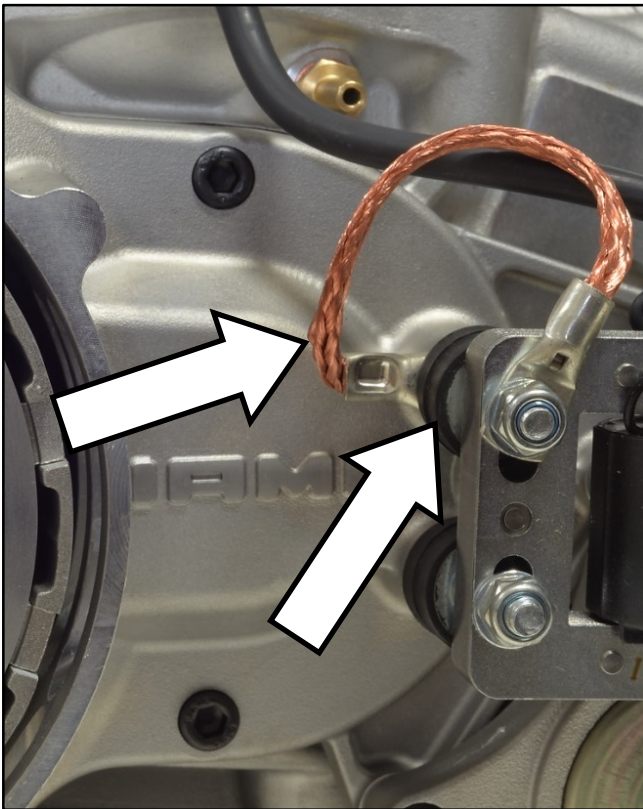

ELECTRIC CONNECTIONS 2015

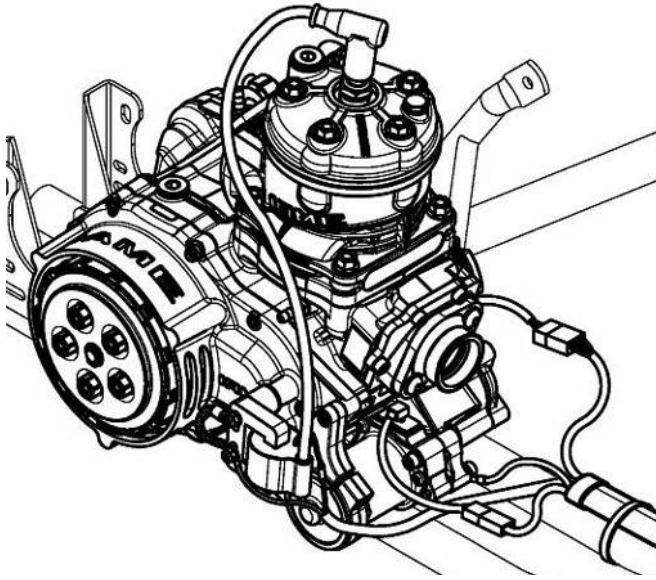

RIGHT SIDE CHASSIS

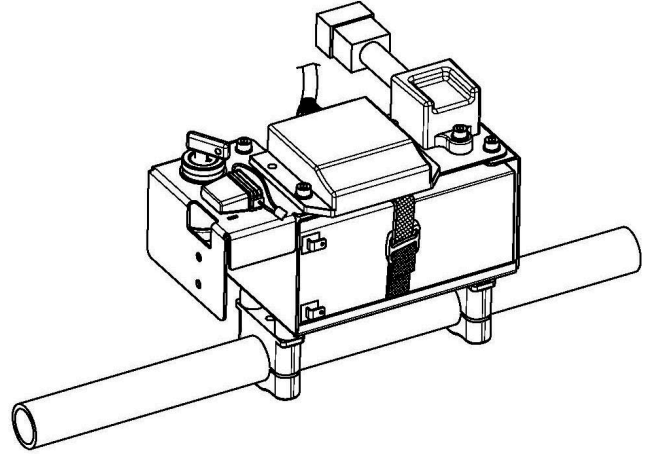

LEFT SIDE CHASSIS

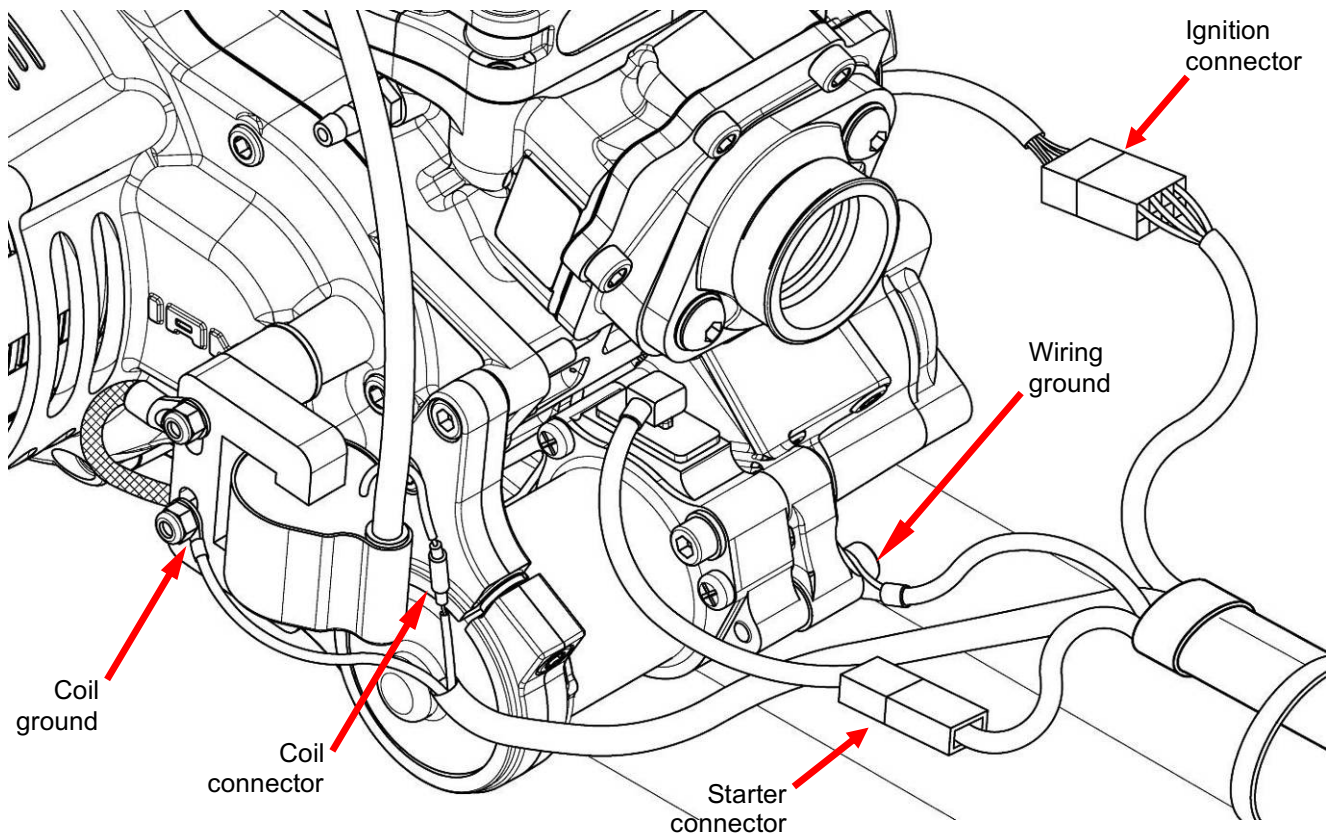
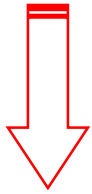

INSTALLATION START / STOP KIT BUTTONS IN POSITION OF KEY BLOCK

ASSEMBLY ESPLODED VIEW

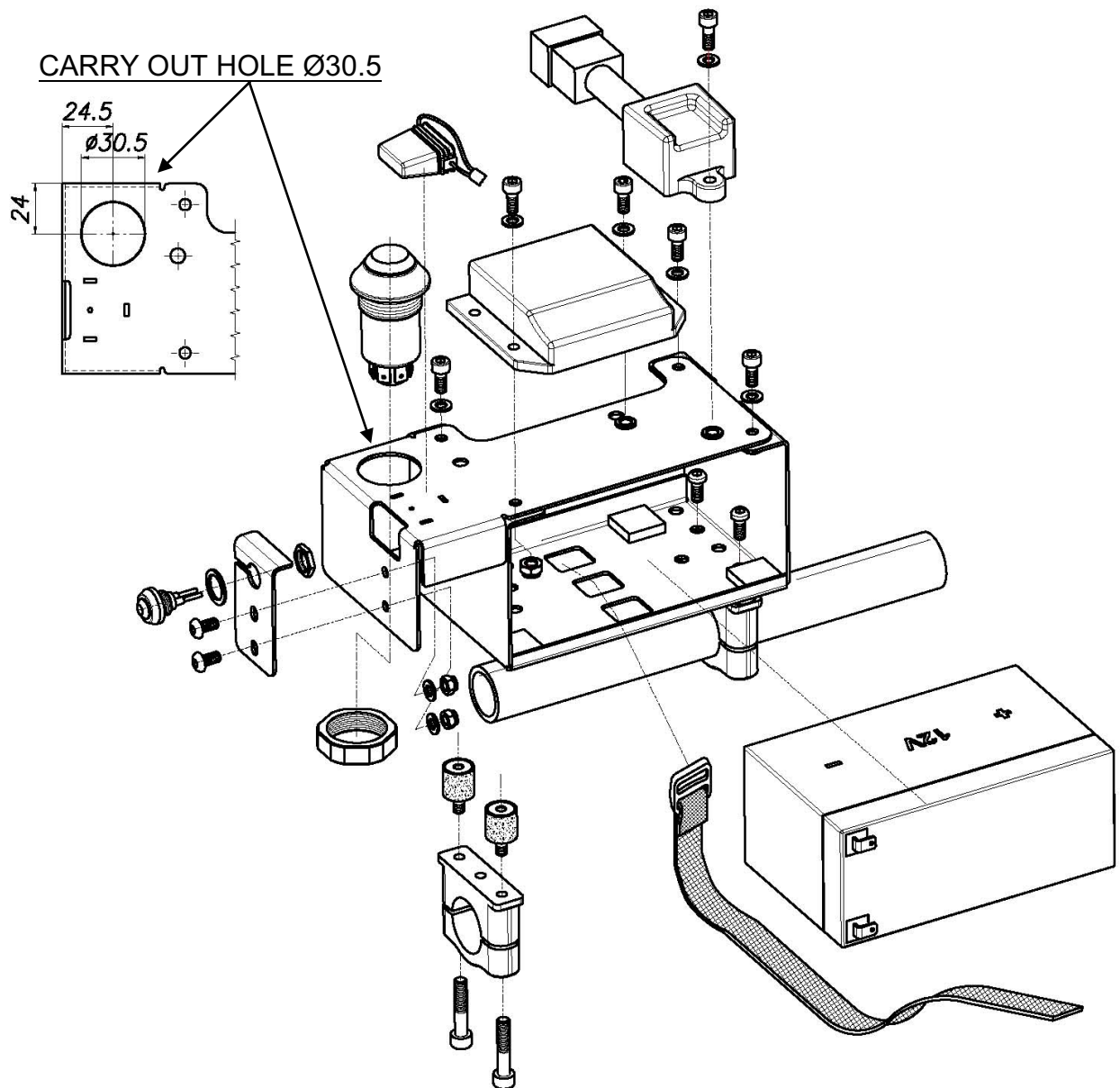

INSTALLATION COMPLETED

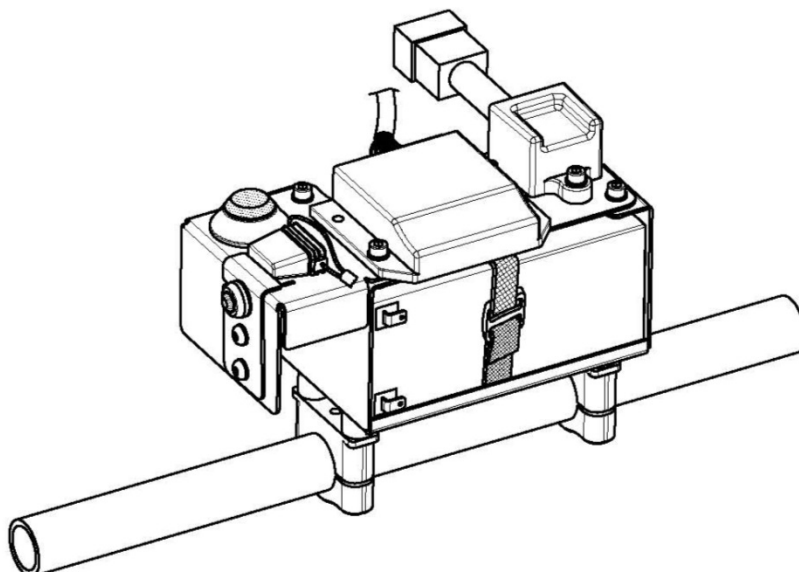

FUEL PUMP

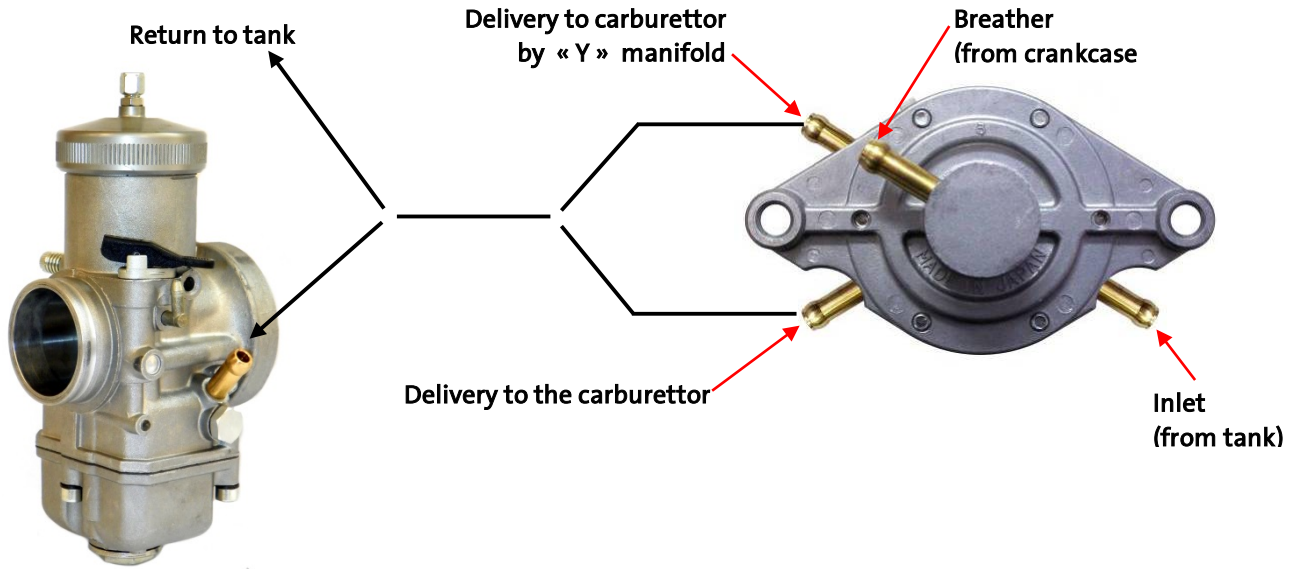

IT IS RECOMMENDED TO TURN THE CONNECTIONS OF THE FUEL PUMP SECOND FIGURE FOR A MORE 'ARRANGEMENT OF CORRECT CONNECTIONS.

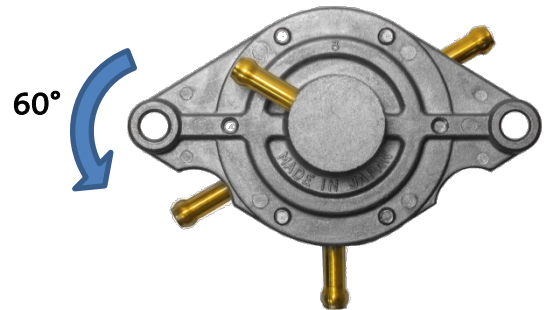

INSTALLATION OF PUMP BRACKET

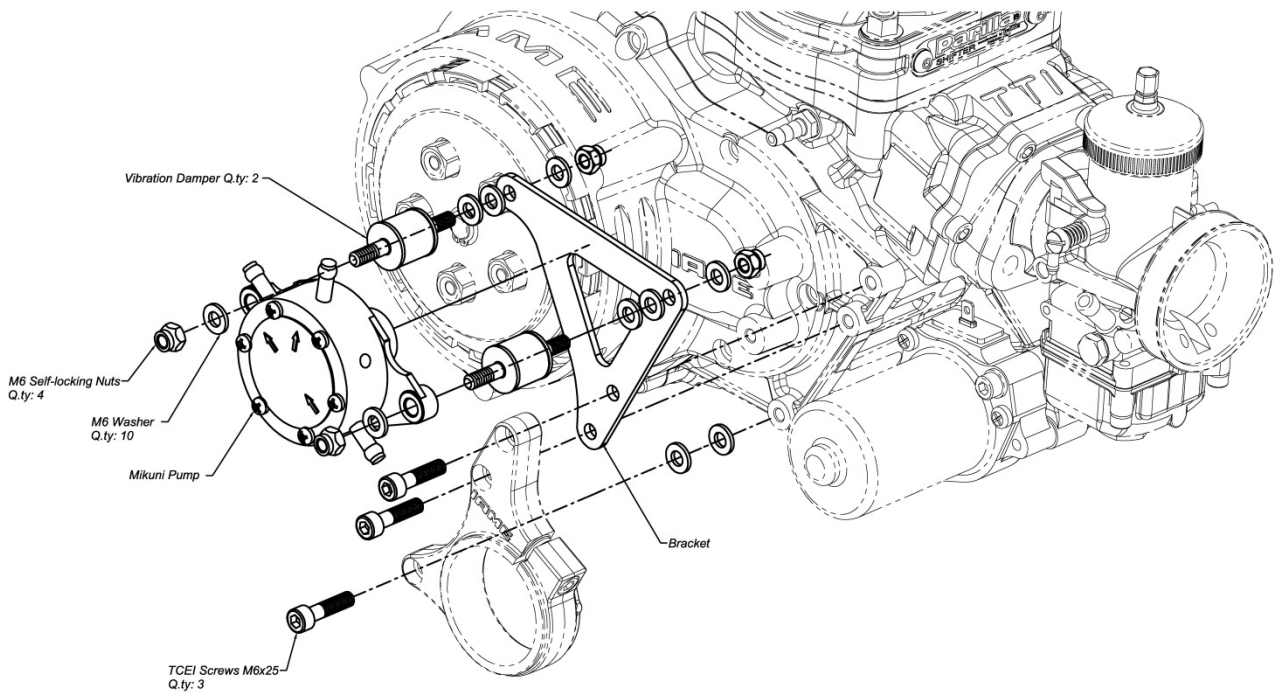

REMEMBER TO CONNECT THE COPPER WIRE AND THE OTHER CONNECTIONS AS SHOWN IN THE PICTURE OF THE PREVIOUS PAGE

CORRECT FEEDING PIPES CONNECTION

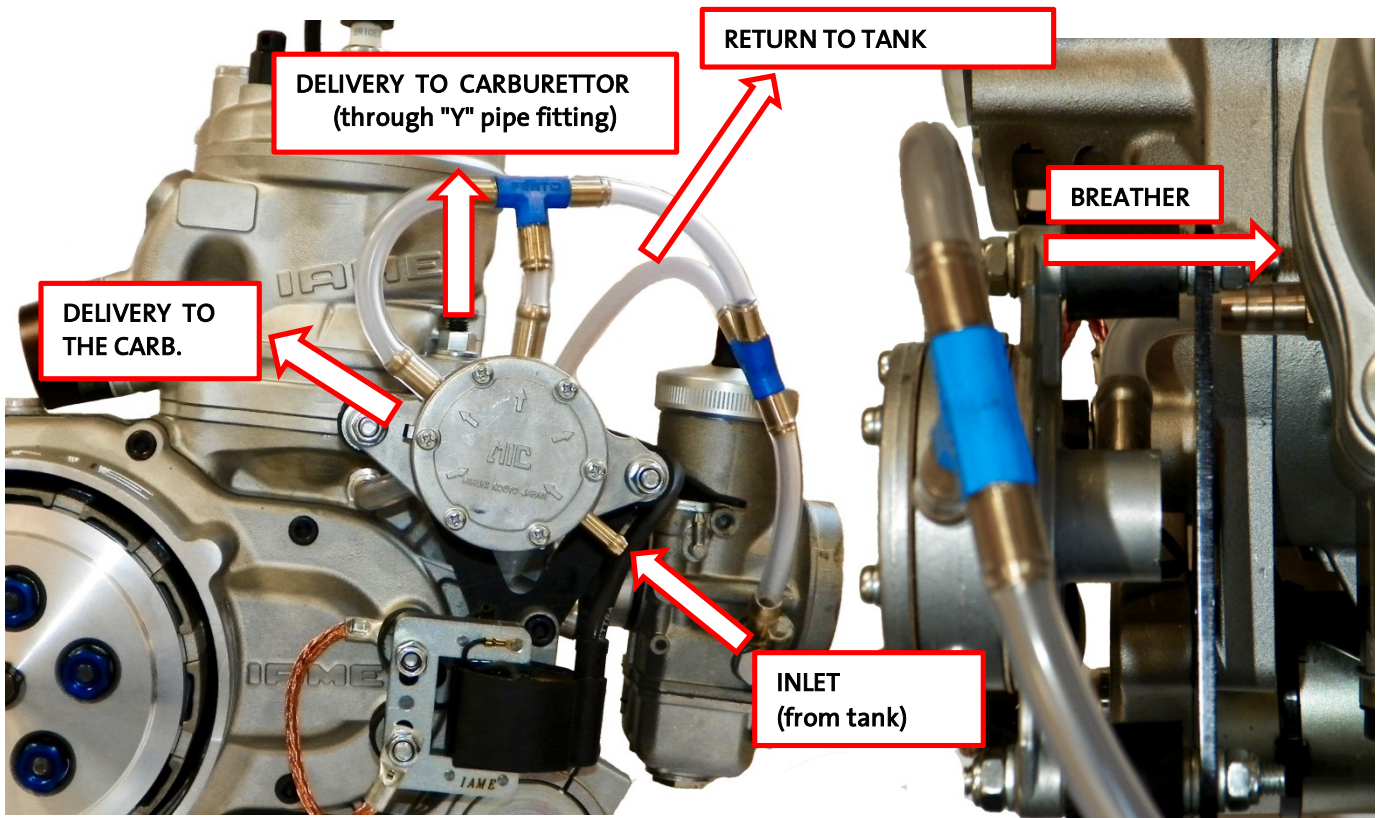

STEERING-WHEEL CLUTCH LEVER SETTING

Whereas the IAME clutch is equipped with a system to make the drag more progressive, needs a clutch lever stroke little bit longer to disengage completely. To the proper lever setting, we therefore recommend that while the lever is fully pulled all the clutch is actually disengaged (rotation free by hand of disc thrust plate).

EXHAUST GAS TEMPERATURE PROBE

The muffler, supplied with the engine is provided with a temperature probe fitting which is not drilled. Whenever you wish to employ the probe, please proceed as shown in the figure below.

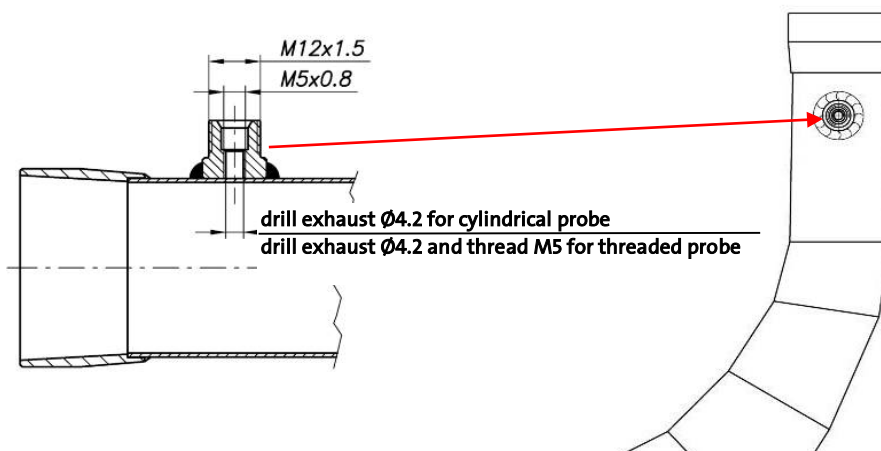

MAIN ENGINE COMPONENTS AVERAGE ESTIMATED LIFE

The estimated life of the different components, of the engine, changes according to the use and to the desired performance.

PISTON / CYLINDER MATCHING

The piston replacement must take place within specific intervals, measured through used mixture liters and it changes depending of the engine use, if for competitive use (so to reach the better performance) or not competitive.

IAME suggests to replace the piston during the competitive use any **60lt~**, or before whenever the clearance between piston and cylinder exceeds **0.14mm**.

For NOT competitive use the replacement must take place any **90lt~** of mixture or whenever the clearance between piston and cylinder exceeds **0.14mm**.

The prescribed clearance between cylinder and new piston, by selection **GREEN**, is **0.10÷0.11mm**.

The prescribed clearance between cylinder and new piston, by selection **RED**, is **0.11÷0.12mm**.

The effective piston diameter has to be verified at **18mm** from the base, perpendicularly to the piston pin.

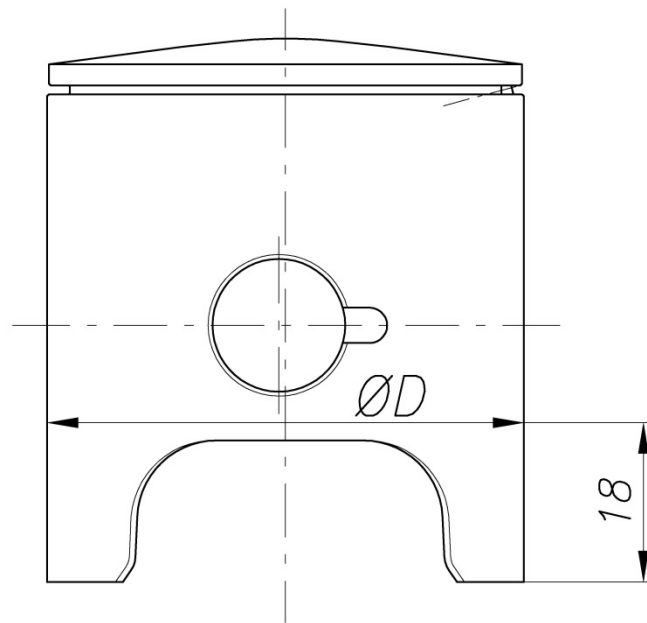

The measure marked on the piston top is the effective one of the piston.

Moreover, the clearance between the piston ring tips (installed in the cylinder) must be between **0.35÷0.40 mm**.

The clearance can be checked with a feeler gauge, by inserting the ring in the cylinder.

MAIN BEARINGS

With the roller bearing, the life of these ones is same to a full sporting season.

CONROD BIG END CAGE, CRANKPIN AND SHIM

During the competitive use we suggest the replacement every **90lt.**
For NOT competitive use the replacement can be made about every **130lt.**

SMALL END CAGE

During the competitive use we suggest the replacement every **60tl.**
For NOT competitive use the replacement can be made about every **90lt.**

CONROD

During the competitive use we suggest the replacement every **180lt.**
For NOT competitive use the replacement can be made every **260lt.**

Anyway it must be replaced whenever the big end hole ovalization exceeds **0.01mm.**

This value is the difference between the diameter measured in "A" and "B" as below indicated.

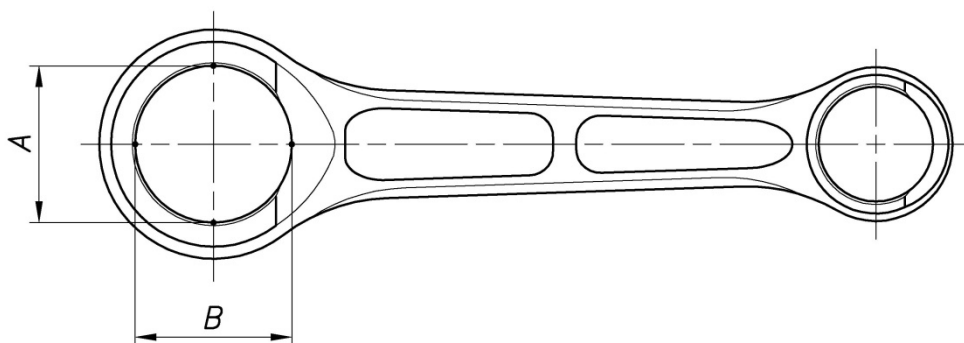

DELLORTO VSH 30 CS CARBURETTOR SETTING

BASIC SETTING X30 SHIFTER

max. jet = 180	atomizer = DP 268	Fuel needle = 300
Idle jet = 60	needle = K98 (3 [^] notch)	Throttle valve = 50
Starter jet = 60		float = 9g
Float chamber level = 11.5mm	Idle emulsion tube = B 100 To check / to update by the customer	

ATTENTION:



THE BASIC SETTING CARBURETTOR IS DELIBERATELY VERY RICH, PLANNED FOR EXTERNAL TEMPERATURE OF 20°C, NOT BEING POSSIBLE TO FORESEE WHICH WILL BE THE CONDITIONS OF THE FIRST USE OF ENGINE.

IMPORTANT: THE FLOAT CHAMBER LEVEL MUST BE 11.5mm MEASURED WITH THE GASKET INSTALLED ON THE CARBURETTOR BODY AS IN THE PICTURE.

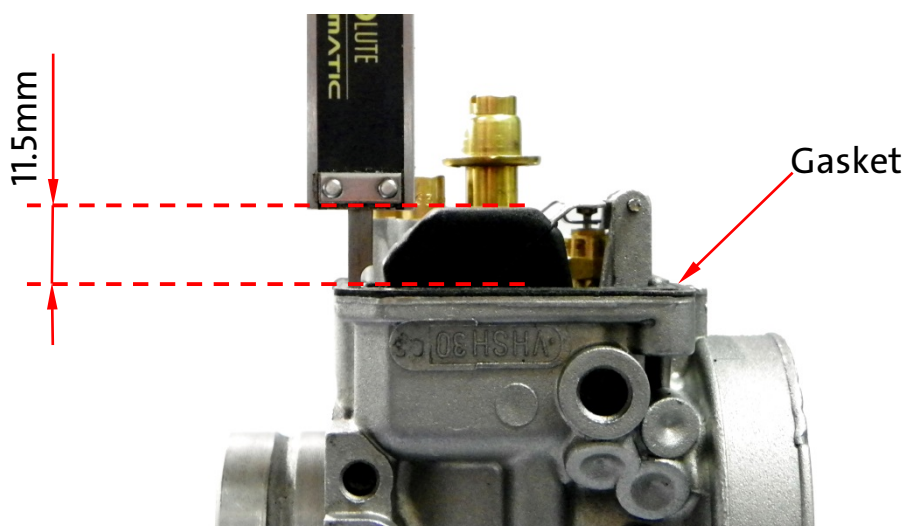

If we remark a different value, please operate on the two metallic plates which support the floats, to obtain the prescribed level.

We recommend to check the level value of both floats, to obtain the same.

Whenever an optimum carburettor setting is required in each condition, it will have to be performed by acting on the adjusting elements to better fit the most proper mixture title according to the track and environmental characteristics.

The operations to be performed for a fine setting require a specific experience which cannot be acquired only through the support of these few lines; our target is to give simple suggestions to find the best carburettor setting according to the operating conditions.

We generally consider three ranges of engine operation: the idle RPM or low RPM, achievable with slightly opened throttle, the mid RPM or transition RPM, achievable with intermediate throttle lever opening, and the max. RPM, achievable with max. throttle opening.

In a float chamber carburettor such as this, there are different devices acting on each specific carburetion areas; their zone of influence are separated, as below illustrated, although affecting each other.

THE IDLE RPM

It can be adjusted by means of the screw "A" (see fig. 1), which acts on the throttle gas by slightly lifting or lowering it. Turning clockwise to RPM increases and turning counter-clockwise to decrease.

THE CARBURATION AT IDLE RPM

It can be set by means of:

- the idle jet in the float chamber
- the idle emulsion tube, above the respective jet
- the idle mixture screw air.

Generally, for the standard adjustments, the emulsifier is not concerned. A richer carburetion is obtainable by increasing the idle "L" jet size (see fig. 2), and leaner by decreasing the "L" jet size. The idle jet can be reached by removing the carb. float chamber. A richer carburetion can also be achieved even turning clockwise the air screw "B" (see fig. 1) and, conversely, turning it counter clockwise you get a leaner carburetion. It is recommended to adjust gradually by 5'÷10' each time, then check the obtained result.

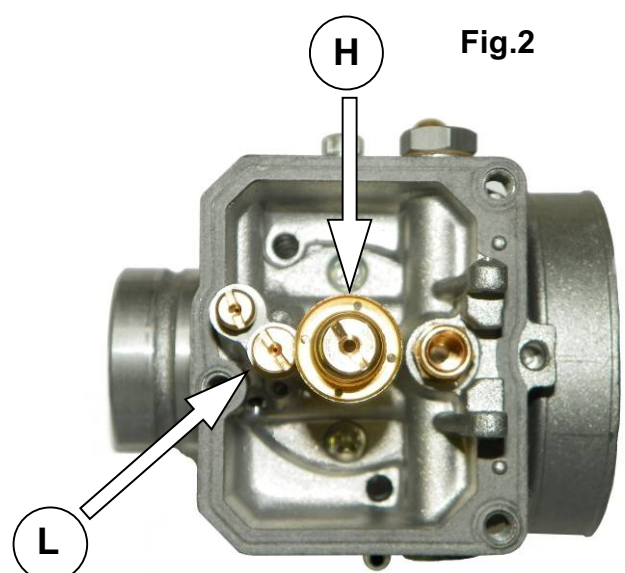
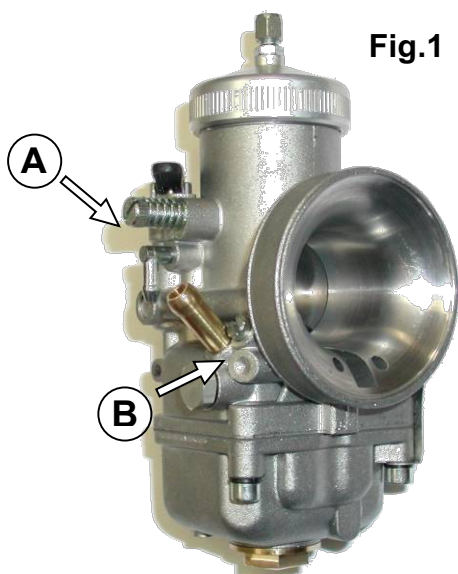

THE CARBURATION AT MID RPM

It can be set by means of:

- conical needle
- the spray nozzle

The conical needle acts as shutter on the spray nozzle hole, and its axial position is determined by the throttle opening. Thanks to its particular conical configuration, when the throttle gradually opens, the needle creates a less shutter in the spray nozzle hole, regulating consequently the fuel flow.

The needle and the spray nozzle have been chosen to satisfy the different conditions. The carburetion setting is performed by lifting or lowering the conical needle vs. the throttle.

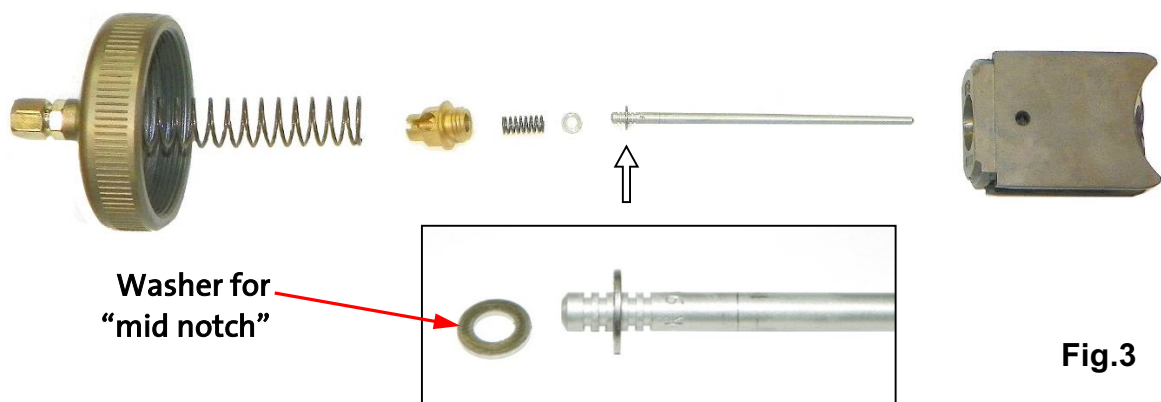

A richer carburetion is got by lifting the needle, by moving down the retainer clip to a lower notch; obviously a leaner carburation is got by lowering it, so moving the retainer clip to an upper notch. (see fig. 3). The basic needle adjustment is shown on the picture.

At the conical needle, is accessed by unscrewing the upper cover of the carb.; then pull off the throttle valve together with the needle, off hook the throttle cable, and unscrew the fixing screw on the valve itself.

THE CARBURATION AT TOP RPM

It is mainly performed only by means of:

- the max. jet

By increasing the max jet size "H" (see fig. 2) we will get a richer carburation and , conversely, a leaner one by decreasing the jet size.

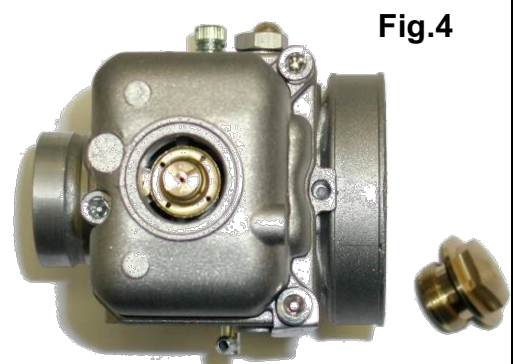

To reach the max jet , unscrew the central plug on the float chamber (see fig. 4), or disassemble the float chamber itself.

As anticipated just above, there is no clear distinction among the areas of influence of the various components, as they interact and influence each other. Generally the max jet affects not only the carburation at max open throttle but also the whole mid-range carburation, even if less sensibly vs. the needle position; therefore the needle position slightly influences also the carburation at wide open throttle.

In the same way, when the throttle is slightly opened, the effects of the min jet and the air screw overlap with conical needle position effects.

To properly adjust the carburetion according to the ambient conditions, we are giving some indicative parameters to adapt the max. jet size as a function of the variation of the ambient temperature and the altitude at which the engine is operating.

As you know the carburetion, so the exact fuel quantity to be mixed to a given quantity of air, is influenced by atmospheric factors, such as temperature and pressure. The more the temperature drops, the more the air density increases and consequently, there will be more molecules of gas in the same volume taken in by the engine. As the carburettor mixes always the same fuel quantity, this would be insufficient and the carb. will provide a leaner mixture. When operating with a leaner carburetion, the engine runs the following risks: overheating, insufficient lubrication, detonation, seizure; this is the reason why **the carb. setting must be adjusted by increasing the max jet by about 2 points for every 5°C. external temperature drop.**

Of course, on the contrary, the more the temperature rises, the more the carburetion becomes richer and gives origin to less critical consequences than the ones experienced with a leaner carburetion. So in this case also, it is suggested to optimize the carb. setting **by decreasing the max. jet size by about 2 points for every 5°C external temperature increase.**

The variation of the atmospheric pressure, which is significant when varying the altitude, gives origin to the same phenomenon; by decreasing the altitude, the atmospheric pressure increases, consequently in the same air volume taken in by the engine, more molecules of gas are present. Therefore, in this case too, a carb. adjustment is required, **we suggest to increase the max jet size by approx. 2-3 points for every 350m altitude decreasing.**

On the contrary, by increasing the altitude it is necessary to **reduce the max. jet size by about 2-3 points for every 350m altitude increasing.**

The above data are merely indicative, as many factors influence the carburetion and only a few are easily ponderable. With these indications we wish to give the user a general guide line and avoid damaging the engine under environmental conditions which make the carburetion substantially leaner.

A fine carb. adjustment will always have to be performed according to the experience and to the tests on track.

As completion of this guideline, here are a few general recommendations.

The carburettor is provided with an enrichment system to start the engine, (lever "C" - see fig. 5) when it is cold and/or when it has been kept inactive for a certain time. To get the max. efficiency, this device must be used with gas throttle closed or slightly opened. A few seconds after the engine has been started, shut the enrichment system to avoid engine flooding .

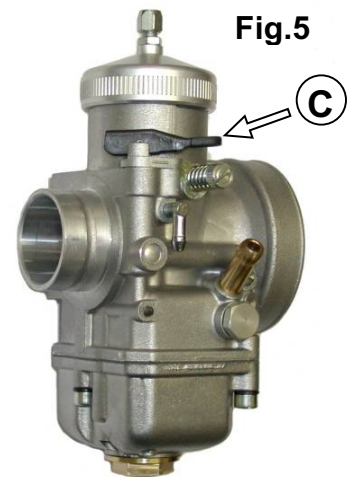

Fig.5

The only problems which could be experienced with these carburettors are connected to the fuel feeding.

The fuel feeding is regulated by the floater-valve system located in the float chamber.

In case the fuel contains impurities, preventing the proper admission valve closing, the level in the float chamber increases, and the exceeding fuel is discharged through the carb. vents. In this case, it is necessary to disassemble the float chamber, remove the floaters and the fuel valve and clean it with compressed air (see fig.6 - 7).

In case of puncture of one or both floaters, the fuel valve cannot be closed, and so the exceeding fuel overflows through the vents. It will be then necessary to disassemble the float chamber, check the floaters status and eventually replace them with others having the same weight.

In case the engine has to remain out of operation for a long period, the fuel admission valve could get stuck (either on opening or on closing positions) for incrustations.

In the first case presents the same phenomenon of fuel overflowing from the vents of the carburettor, in the second, the engine won't start for insufficient feeding.

It is necessary to disassemble the float chamber, and check if there is fuel inside, remove incrustations and re-establish the proper fuel admission through the floater-valve assembly.

Fig. 6

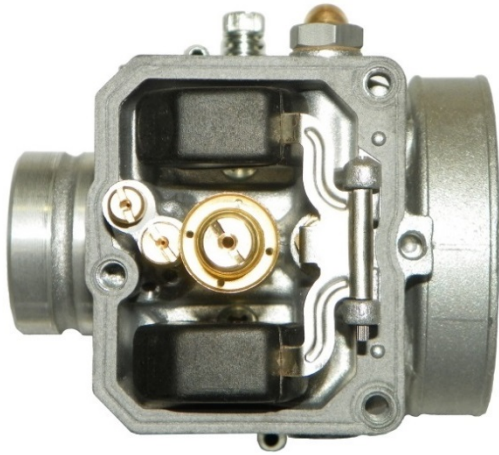

Fig. 7

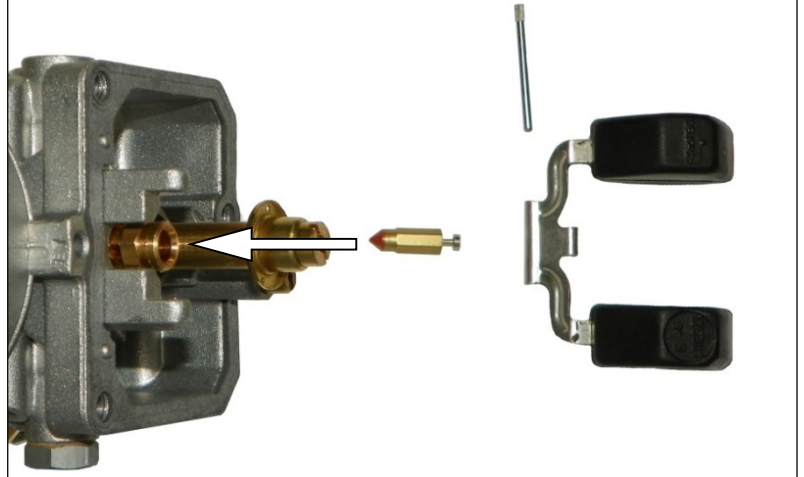

TABLE SETTING CARBURETTOR OPTIMIZED FOR COMPETITIVE USE

ENVIRONMENT TEMPERATURE	NEEDLE	NOTCH	ATOMIZER	MAX. JET	IDLE JET	THROTTLE GAS	AIR SCREW MIN.
20°C	K93	2 nd ½ (2nd and washer below)	DQ265	165	B100-68	50	1 ROUND e 3/4
10°C	K93	2 nd (2nd and washer above)	DQ266	170	B100-68	50	1 ROUND e 3/4
2°C	K93	3 rd (3rd and washer above)	DQ 266	175	B100-63	50	1 ROUND e ½
Rain	K93	1th ½ (1th and washer below)	DQ266	160	B100-68	60	1 ROUND e 3/4

TECHNICAL DATA ENGINE SUMMARY TABLE

DESCRIPTION	DATA	NOTES
FUEL MIXTURE / FUEL	4 % OF OIL	98 RON Oil CIK homologated
GEARBOX OIL	350 ml	specific: SAE 75W or SAE 75W90 or SAE 10W50
OPERATING TEMPERATURE ENGINE	min.50°C / max.58°C	
EXHAUST ANGLES TIMING REFERENCE	195°	Feeler gauge 0.2x5mm
TIMING ADVANCE	1.6 mm	before the T.D.C.
COMBUSTION CHAMBER VOLUME	13.2 cm ³	13 cm ³ min.
SQUISH	1.1 mm	Measured with single wire from 1.5mm
CORRECT MEASURE TIPS PISTON RING	0.35 ÷ 0.40 mm	installed in the cylinder
SPARKPLUG TYPE USE IN STANDARD WEATHER CONDITIONS	NGK BR 10 EG NGK R6254E – 105	
SPARKPLUG TYPE USE IN RAIN ATMOSPHERIC CONDITIONS	NGK BR 9 EG	