

# LOEWER

## DiscMaster SF

Deburring, edge rounding and oxide removal

Top and bottom in one pass



FOR LASER-CUT AND PUNCHED PARTS

FOR FLAT AND 3D FORMED PARTS

FOR FOIL-COVERED SHEET METAL

FOR ZINC-COATED SHEET METAL

### 360° deburring and edge rounding from top and bottom

The DiscMaster SF is equipped with oscillating disc stations on the top and on bottom. These discs with flexible abrasive sanding strips rotate and oscillate over the workpiece. The inside and outside edges are processed from all angles and directions resulting in uniform edge rounding independent of the orientation of the cutting contours.



#### The workpiece transport

- work pieces are fed through the machine by rubber covered rollers with adjustable feed speed
- the sanding strips can be set below the level of the rollers - a big advantage over a feed belt drive
- three-dimensional formed parts can be processed due to the softness of the feed rollers

#### The 360° processing principle

The work pieces are placed on the feed rollers. The rotating discs oscillate continuously over the work piece. Different disc tools can be used on the different disc stations, depending on the application. The grade of edge rounding can be adjusted by setting the pressure, the disc rpm, the feed speed and the grit size of the abrasives.

#### The tools

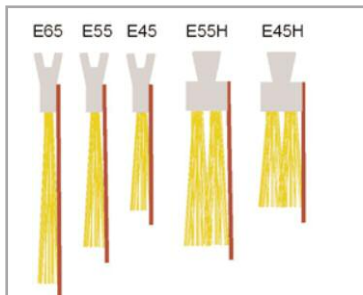

High quality abrasive sanding strips available in different heights, gritsizes, cutting widths and support brushes



Grooved discs for holding sanding strips



Stainless steel wire brushes for oxide removal

The Discmaster SF is available in two different models:

### DiscMaster SF1/1:

One oscillating disc station from top, one from the bottom, in 1000mm or 1500mm working width. This is the reasonable priced model for 360° top and bottom processing. When equipped with Smart-Flex sanding strips it is ideal for deburring/edge rounding formed parts, zinc-coated parts or foiled sheet metal - parts which are difficult for standard abrasive belt deburring machines. When equipped with stainless steel wire brushes the machine is ideal for 360° oxide removal in one pass.

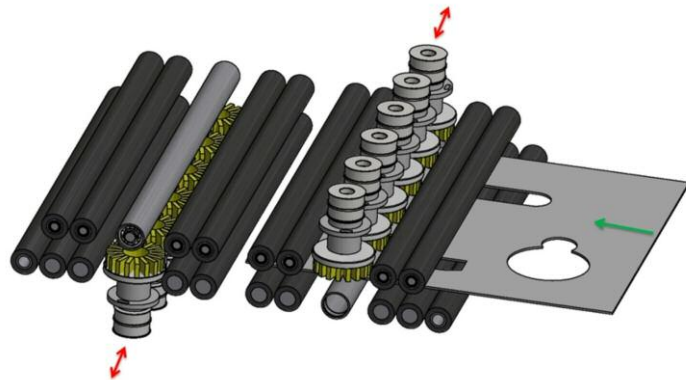

DiscMaster SF 1/1

### DiscMaster SF 2/2:

Two oscillating disc stations from top, two from the bottom, in 1000mm or 1500mm working width. For more pronounced edge rounding it is possible to use different grit sizes, e.g. grit 60 on the first and grit 80 on the second units.

When using Smart-Flex sanding strips on the first and stainless steel wire brushes on the second units the machine is ideal for edge rounding and oxide removal of laser cut steel parts in one pass.

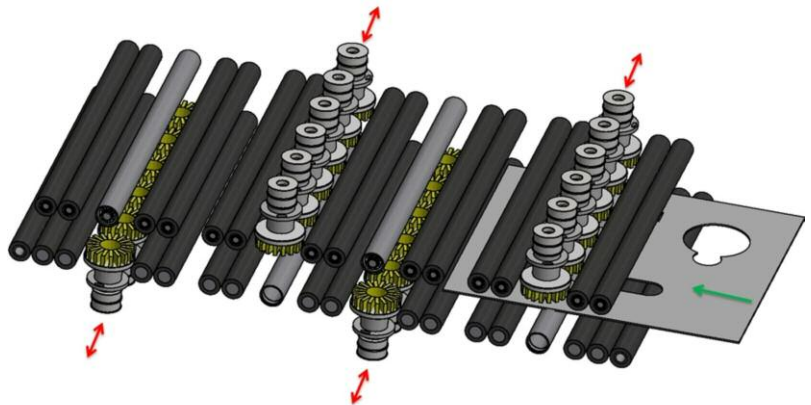

DiscMaster SF 2/2

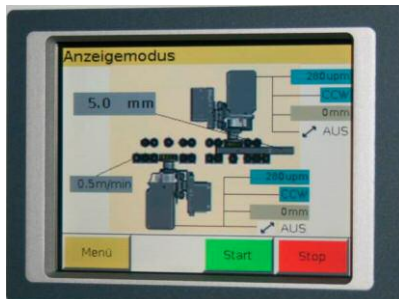

### TouchPanel Control

The DiscMaster SF is equipped with a modern Touch Panel Controls and step motors for quick and exact setting. The disc units, oscillation motors and the feed speed are infinitely adjustable using frequency inverters. Also it is possible to store machine programs and the machine is very easy to use.



### Even wearing of abrasive tools

The optional workpiece scanning device detects the position of the workpieces in the machine. Lights on the infeed side show the operator where to preferably place the next workpiece on the conveyor rollers in order to achieve an even wearing of the abrasives. This simple but effective solution will keep the abrasive costs down.

### The Advantages

- Top and bottom processing in one pass
- Uniform 360° edge rounding independent of direction of contour
- Adjustable grade of edge rounding
- Possible to set abrasives below roller level
- For laser-cut or punched parts
- For flat or formed parts
- For oxide removal
- Very gentle on surface when processing zinc-coated or foiled parts
- Low energy consumption
- Silent processing
- Very forgiving with differences in material thickness
- Easy to use Touch Panel

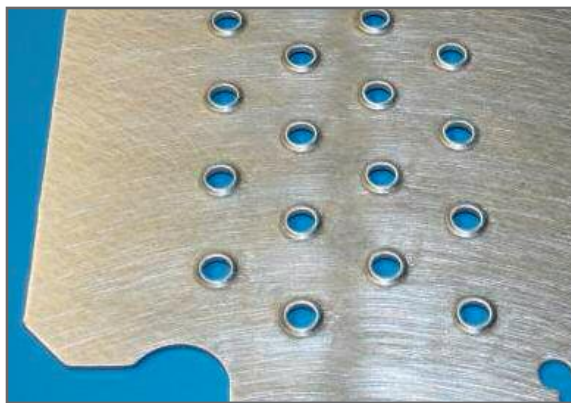

### Technical Data

#### DiscMaster SF 1/1-1000 (1500)

- Max. working width 1000mm (1500mm)
- One disc station top, one disc station bottom
- Disc station with 6 discs (9 discs), with separately variable rpm using frequency inverters, separate height adjustment by step motor, individual oscillation by gear motor, disc diameter 150mm
- Rubber-covered feed rollers and rubber covered spring-loaded hold down rollers, variable feed speed 0,5 - 4m/min by frequency inverter
- Motorized height adjustment of workpiece thickness
- Touch Panel controls
- CE

#### DiscMaster SF 2/2-1000 (1500)

- Max. working width 1000mm (1500mm)
- Two disc station top, two disc station bottom
- Disc station with 6 discs (9 discs), with separately variable rpm using frequency inverters, separate height adjustment by step motor, individual oscillation by gear motor, disc diameter 150mm
- Rubber-covered feed rollers and rubber covered spring-loaded hold down rollers, variable feed speed 0,5 - 4m/min by frequency inverter
- Motorized height adjustment of workpiece thickness
- CE

### Optional Extras:

- Workpiece scanning device with indication lights for a more even wearing of abrasive tools
- Large range of Smart-Flex sanding strips
- Stainless steel wire brushes for oxide removal
- Suitable dust extraction units