

# Electric Skateboard User's Manual

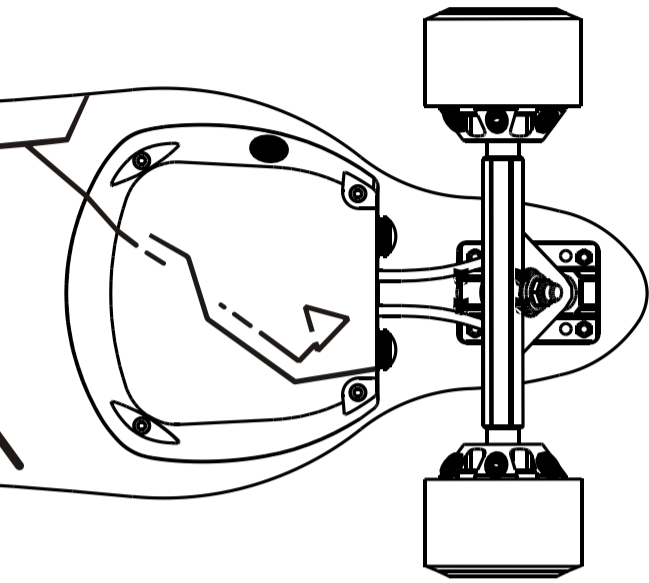

**CAUTION:** Do not Attempt to Modify/Open the Battery, Avoid Short Circuiting the Battery, and NEVER expose the battery to Water, Fire or Extreme Heat.

UN38.3 CE FC RoHS

MADE IN CHINA

## ! WARNING !

- Please ride the electric skateboard carefully to protect yourself. We strongly recommend you to wear the protective gears and ride on flat surface.
- Safety Gear – please wear a suitable skateboard helmet, elbow pads, knee pads, and gloves.
- The skateboard is designed for users aged from 13 and older.
- The skateboard provides a maximum load 120kg. Overweight will affect the balance and function of the skateboard.
- The skateboard is designed to be ridden on flat and paved surface. Never ride in sands, gravel, mud, rugged or wet surface as well as slippery ground, such as snow, ice or wet ground.
- Please always follow the local laws and regulations when riding.
- Do not use or charge skateboard in a place where the temperature over 40°C or below 0°C.
- **WARNING: AVOID WATER!**  
Your board is not completely waterproof, you can easily go through the puddles but don't soak the board in the water. Any damage caused by water is not covered by the warranty policy.
- **WARNING: PINCH POINTS!**  
Keep fingers, hair, and clothing away from belts, motors, wheels, and all spinning parts.
- **WARNING: RISK OF ELECTRONIC SHOCK!**  
Do not open or tamper with electronics housing, which also voids the warranty.
- **WARNING: UNDER LOW BATTERY CONDITION!**  
Do not go uphill or downhill when the board or remote control is low battery condition, which may cause the skateboard to lose power and brakes.

## STORAGE AND MAINTAINANCE

- Do frequent maintainance checks, make sure all screws are tight before riding.
- Clean the bearings regularly.
- Turn off skateboard and remote control when not in use.
- Recharge the battery in well ventilated area.
- Do not charge the battery in area where it might wet the skateboard or charging devices.
- Do not leave the skateboard charging unattended.
- Stop using the product or charging unit if any wire is damaged.
- Only use charging units supplied by us (INPUT: AC100-240V~50/60Hz 1.8A OUTPUT: 42V, 2A).
- Do not use the skateboard battery to power any other equipments. Store indoors when not in use.
- Please charge the battery at least once every three months when your Skateboard is in storage, it will be helpful to restore the battery performance and avoid the battery damage caused by self-discharge.
- Please charge the board within 24 hours every time after riding. Otherwise, it will lead to a serious battery quality problem if the board doesn't be recharged in time after deep discharge.
- It is recommended to shut down the products to avoid the battery over-discharge when the battery indicator light shows the low battery alarm.

— 1 —

## BEFORE YOU RIDE

1. Make sure the skateboard is fully charged.
2. Make sure the remote control is fully charged and paired with the skateboard.
3. Wear protective gears.
4. Check the screws and wheels.
5. Abide local laws and regulations.
6. Please avoid riding the skateboard on bumpy road and sharp rocks or the wheels may be cracked.

## PROTECT

### ALWAYS WEAR A HELMET

Find an open, flat and safe area for you first ride. Please ride the manual and pay attention to all the warnings before riding.

### OTHER PROTECTIVE EQUIPMENT IS HIGHLY RECOMMENDED

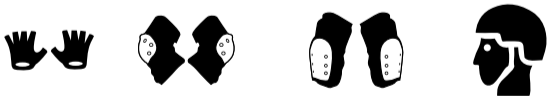

## STANCE

Follow these tips to ensure a safe riding experience.

- Always move the thumb throttle in small increments. Bend your knees and keep a wide stance.
- Don't put your rear foot too far back onto the tail, as this may cause you to lose your balance.
- When Accelerating, Keep your weight on your rear foot but lean in the direction you are Heading. When you need to slow down draker, Keep the foot that is closest to the forward direction and lean towards your rear foot to help brace yourself for the sudden forces.

**Note:** After 5 minutes of standby, the remote control and board will automatically turn off.

## BOARD GLOSSARY AND SPECIFICATION

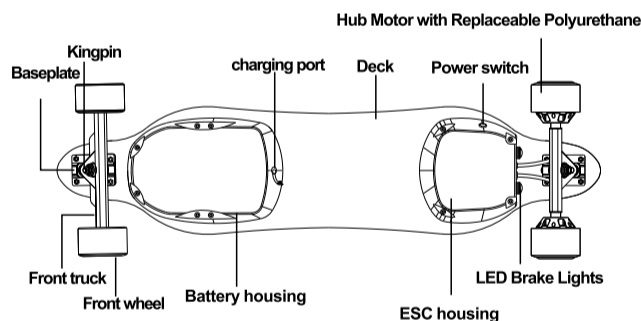

### Capability

Endurance: 15 ± 1Miles / 22 - 26km  
Top Speed: 28MPH / 45km/h  
Maximum Load: 264lb / 120kg  
Slope: 30%

### Entire Board

N.W: 20.5lb / 9.3kg  
Size: 39.4\*12.6\*5.5in / 1000\*320\*140mm

### Motor

Type: 4in / 100mm Hub Motor \* 2  
Power: 4 50W each

### Wheel

Material: Polyurethane  
Size: 4\* 2.2in / 100\* 56 mm  
Hardness: 83A

### Battery

Capacity: 6000mAh  
Type: 36 V Lithium battery  
Weight: 1100 g  
Charging Time: 3 hours  
Cycle life: 500 cycles@ 100% DOD

### Remote Controller

Capacity: 180 mAh  
Battery Type: Lithium Battery  
Charge time: 30 mins

### Board

Deck: bamboo and fiberglass

### Charger

Input voltage and frequency: AC100V-240V, 50-60HZ  
Charging voltage and current: 42V (2A)

**Warning:** The electric skateboard is tested on a smooth, flat surface and no wind condition with maximum load of 176lbs in Ordinary Players mode.

## Remote Control Button Function

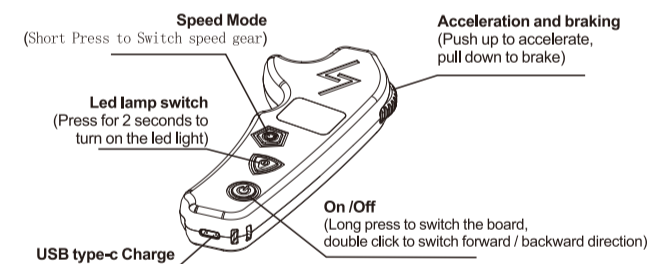

## REMOTE CONTROL DISPLAY

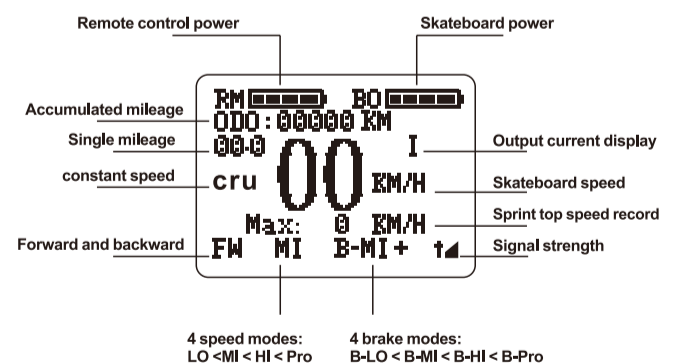

4 speed modes: LO < MI < HI < Pro  
4 brake modes: B-LO < B-MI < B-HI < B-Pro

Unit switch: When the remote control is off, press and hold " LED Lamp Switch" and "On/Off" simultaneously for 2 seconds to display the menu interface, short press " Speed mode " to move to " unit: KM/H MPH " and toggle the scroll to switch kilometers or miles.

Note: the remote control will display the speed and mileage in accordance with counting by 90mm diameter wheels. There is a 10% difference in the display data if 100mm tires are installed. The cruising range and speed will vary according to the rider's weight, riding habits and road conditions.

— 2 —

— 3 —

— 4 —

## USAGE INSTRUCTION OF REMOTE CONTROL

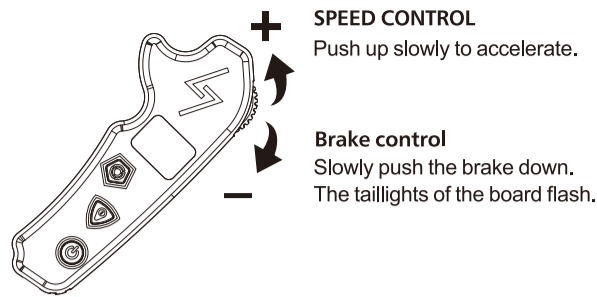

### 4 BRAKING MODES

(Brake and press the speed button meanwhile to adjust the brake mode.)

**Brake strength: B-LO < B-MI < B-HI < B-Pro**  
(Recommend using "B-MI")

### 4 SPEED MODES

(Short press the "speed mode" once, the remote control speed will switch to the next gear, accompanied by a short shock)

**LO=Beginner**

**MI=Ordinary players**

**HI, Pro=Professional Skateboarders**

("HI and Pro" is risky, please use it with caution.)

### CRUISE CONSTANT SPEED

Keep on a specific speed and press the LED button to ride on cruise control function.

(Push to accelerate, brake or short press the "LED button" again to exit the cruise)

### SLIDING START

The board can be turned on by sliding. Don't need to press the power button.  
(Warning: After sliding the board, first brake and then accelerate to avoid sudden acceleration and cause a fall.)

## PAIR

### CHECK IF THE SKATEBOARD IS PAIRED

Your skateboard and remote controller are already paired before shipping, you only need to follow the instruction below.

First turn on the remote control, then turn on the skateboard. When the power indicator flashes quickly and shock, and the remote will shock again, note that it has been paired.

If the above operation does not occur on your skateboard, check if the LED is Lit on showing the power is on. Then enter re-pairing.

— 5 —

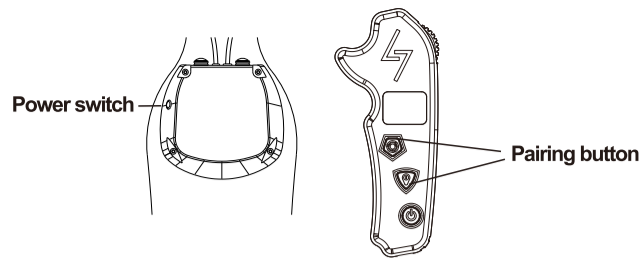

Press the power button of the skateboard or slide the skateboard to turn the skateboard on, then press and hold the power button until the indicator light flashes to enter the pairing mode.

Turn on the remote control, and short press "LED button" and "speed button" at the same time, skateboard indicator light and remote control (Signal strength) Flashes together with two short shocks and A long shock indicates that means the communication connection is successful.

## CHARGING



- 1.Ensure that both skateboard and remote control are turned off when charging.
- 2.The light on the charger will turn red while charging and green when fully charged.
- 3.Normally it will take 3 hours.

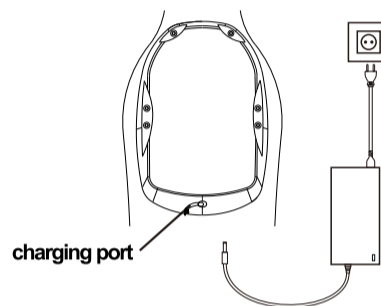

- 1.The remote control uses a standard micro USB cable to charge.
- 2.Normally it will take 30 minutes.

— 6 —

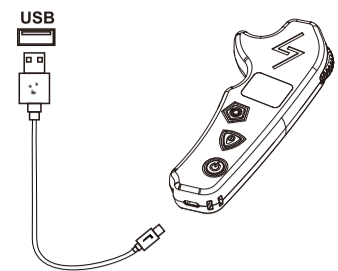

## CHECK THE REMOTE/SKATEBOARD BATTERY LEVEL

The display on the remote control can instantly help you to check the power of the remote control and the board.

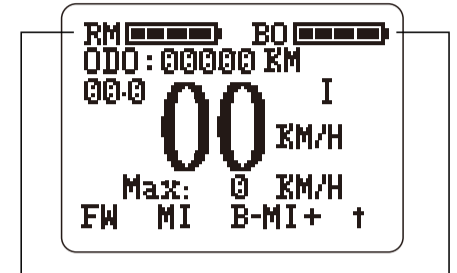

### Remote Battery



### Skateboard Power

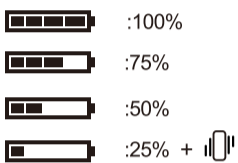

### Remote Battery

When the battery level is less than 10%, the remote control will vibrate every 2 minutes 2 times, when the battery level of the remote control is lower than 5%, push forward Moving the "roller" forward is prohibited, pulling backward "Roller" brake is normal (can't move forward, only brake), remote control will have 2 short shocks every 2 minutes, When the battery level is less than 1%, the remote control will Automatic shut-down after shakes once.

### Skateboard Power

When the battery is below 10%-0%, the fourth frame flashes for 0.5 seconds, The remote control shakes twice every 2 minutes, and the power is lower than 5%, the skateboard cannot accelerate but can only brake. The remote control shakes twice every 2 minutes and should stop riding and charge as soon as possible.

— 7 —

## CHANGE TIRE

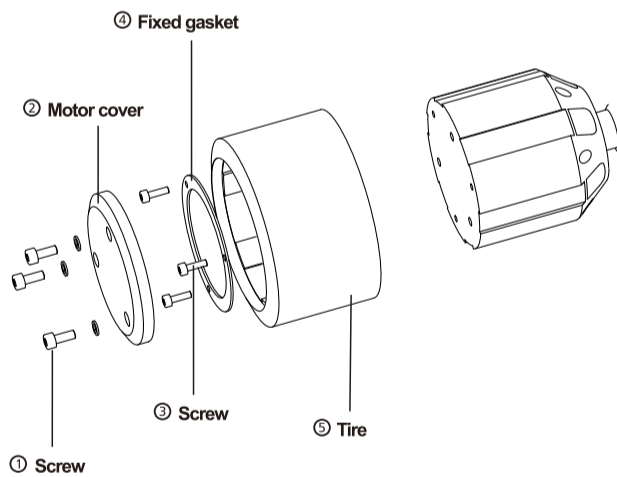

Note: replacement tires need to be purchased separately.

## BATTERY SAFETY

Inappropriate use of the Lithium-ion battery may lead to dangerous results. It is strongly recommended to read the following instructions very carefully:

- Please charge the battery at least once every three months when your skateboard is in storage, it will be helpful to restore the battery performance and avoid the battery damage caused by self-discharge.
- Store the skateboard with battery inside in a dry place.
- Do not charge or use the unit in a car or similar place where the inside temperature may be over 40°C.
- Never leave the skateboard unattended when charging.
- Never use the skateboard while charging.
- Charge the battery for at least 6 hours before it's first use. It will bring a better long-term performance for the battery.

— 8 —

## WARRANTY

### WARRANTY POLICY:

The warranty period for SKATEBOLT electric skateboard (mainboard, battery, motors and remote control) is 6 months from the date of purchase (against defects in material and workmanship).

Damages caused by inappropriate operation, negligence, accident, or riding in deep-water area are not covered by warranty policy .

To return the skateboard, please contact seller for help first.

**Manufacturer's customer service center**  
Email:sales@skatebolt.com

## DISCLAIMER FOR SKATEBOLT

We are doing our best to prepare the content of this site. However, Skatebolt cannot warranty the expressions and suggestions of the contents, as well as its accuracy. In addition, to the extent permitted by the law, Skatebolt shall not be responsible for any losses and/or damages due to the usage of the information on our website. Our Disclaimer was generated with the help of the Disclaimer Template Generator the Terms and Conditions Template .

By using our website, you hereby consent to our disclaimer and agree to its terms.

The links contained on our website may lead to external sites, which are provided for convenience only. Any information or statements that appeared in these sites are not sponsored, endorsed, or otherwise approved by Skatebolt. For these external sites, Skatebolt cannot be held liable for the availability of, or the content located on or through it and plus any losses or damages occurred from using these contents or the internet generally.

— 9 —

## FEATURED PRODUCTS

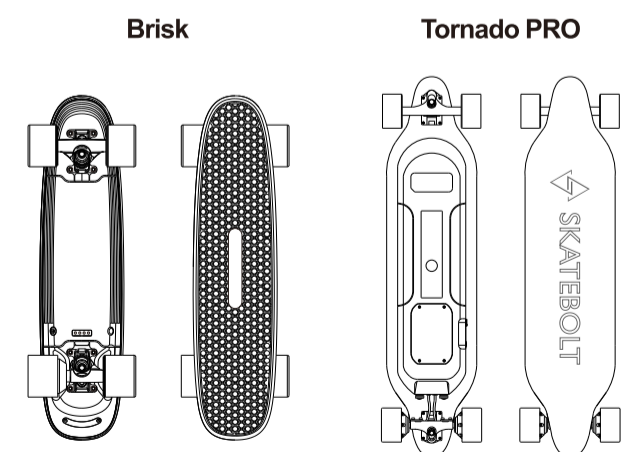
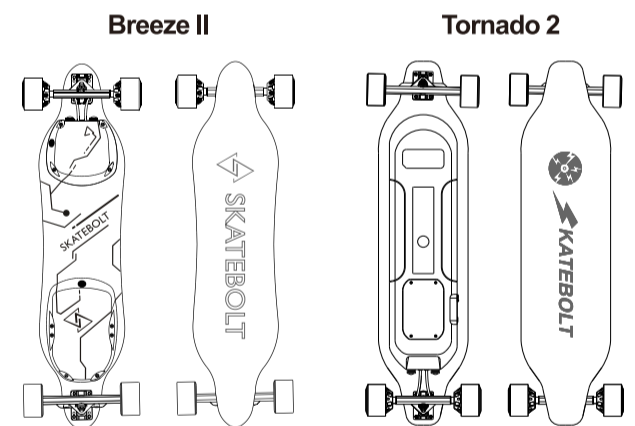

— 10 —