

English

ASSEMBLY INSTRUCTIONS

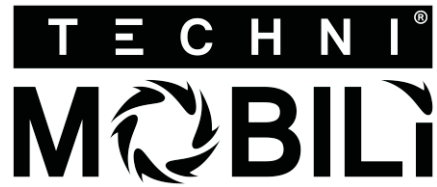

MODEL RTA - 2336

Thanks for purchasing one of our products.
Please read carefully the assembly instructions before the installation.
Please save this manual for future reference.

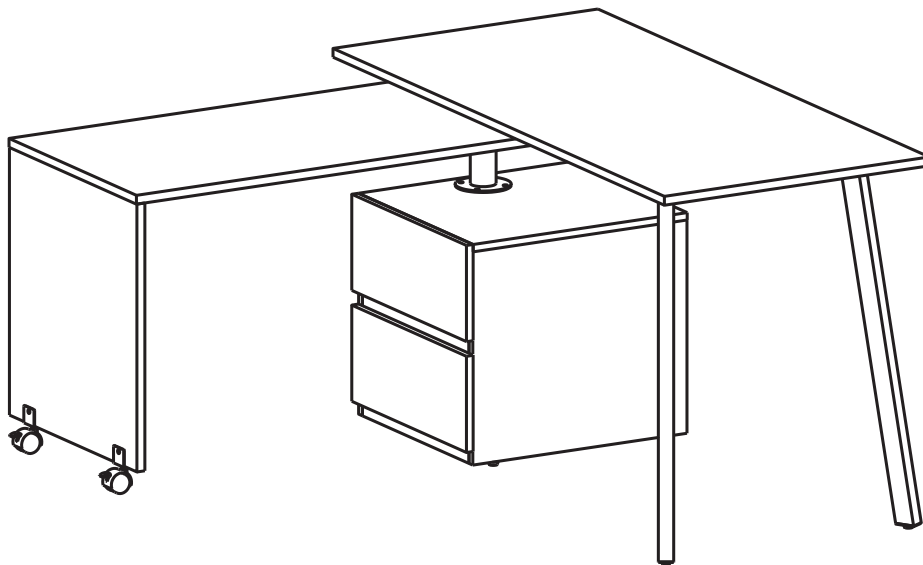

MODEL RTA-2336

RTA-2336

DIMENSIONS

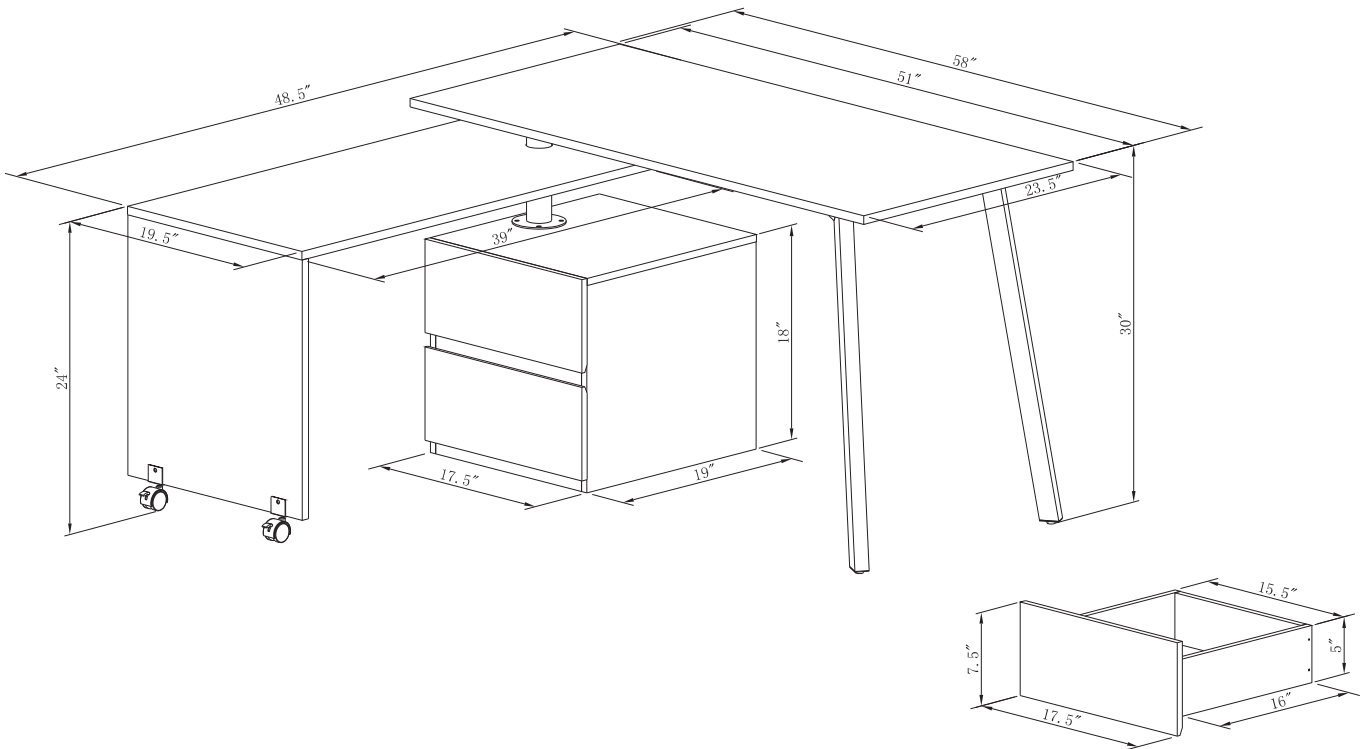

Product Size: 51"-85"W x 23.5"-48.5"D x 30"H



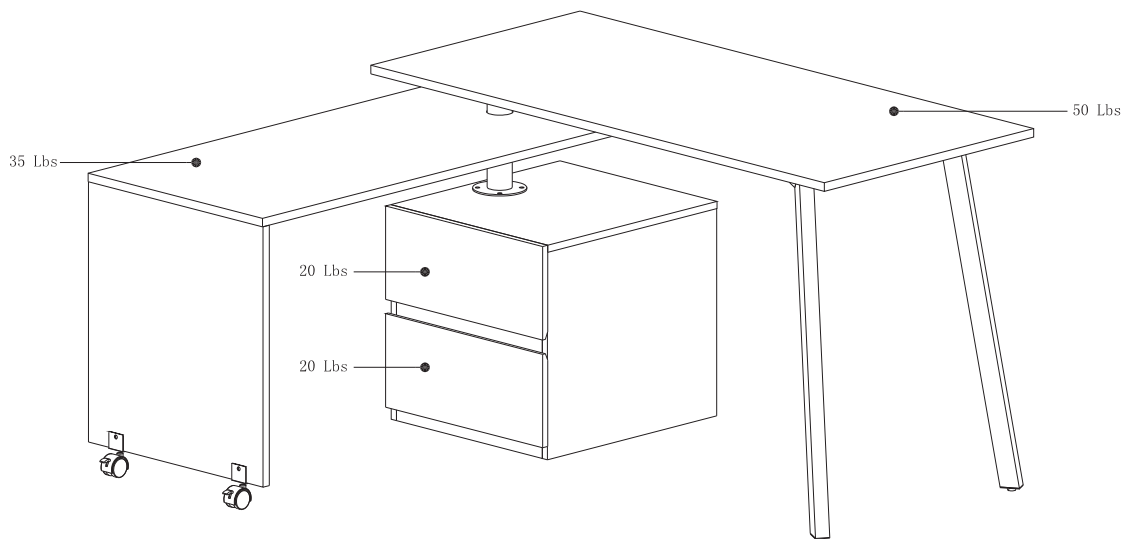

MAXIMUM WEIGHT CAPACITIES



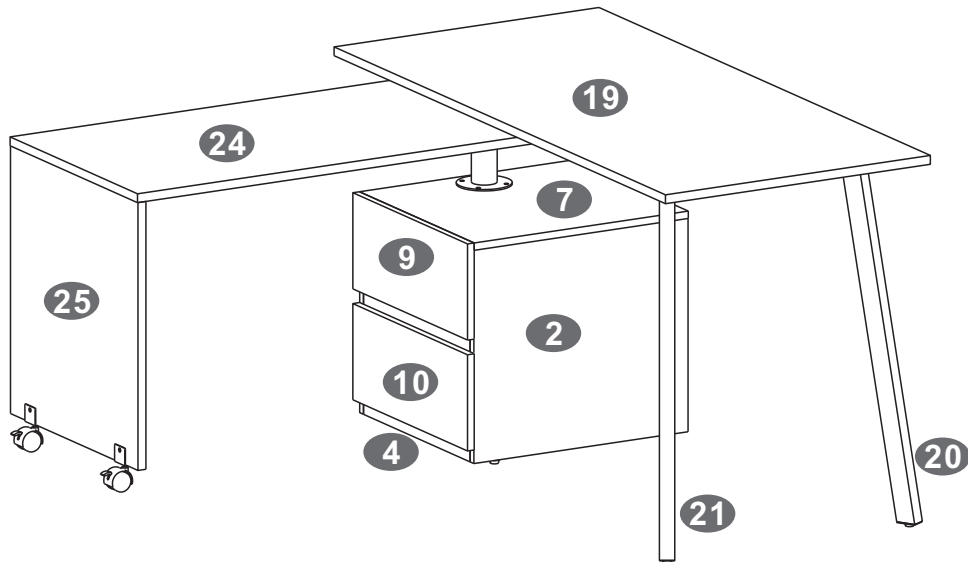

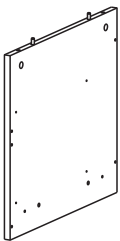
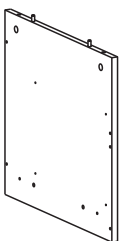
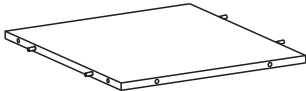

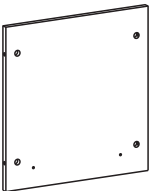

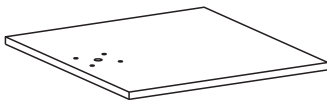
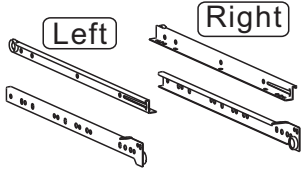
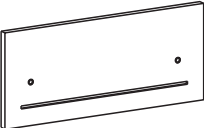
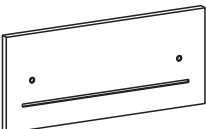
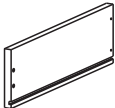
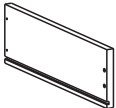

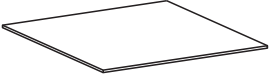

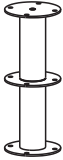

DO NOT exceed this limit
Please use care and good judgement
when placing objects on wood surface

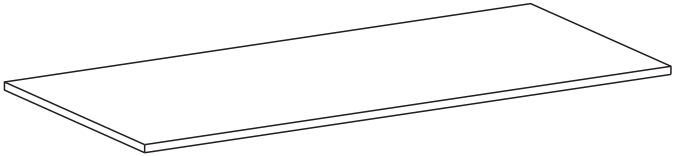



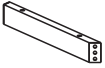
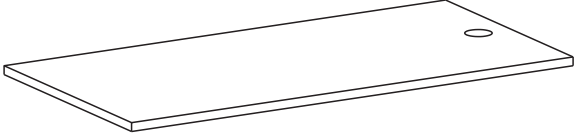
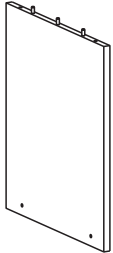



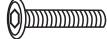
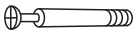

▪PARTS LIST

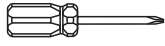

 <p>1 ▪ Left Panel</p>	 <p>2 ▪ Right Panel</p>	 <p>3 ▪ Bottom Panel</p>	 <p>4 ▪ Bottom Front Panel</p>
 <p>5 ▪ Back Panel</p>	 <p>6 ▪ Middle Front Panel</p>	 <p>7 ▪ Top Panel</p>	<p>X2 SETS</p>  <p>8 Left Right ▪ Slider</p>
 <p>9 ▪ Top Drawer Front Panel</p>	 <p>10 ▪ Bottom Drawer Front Panel</p>	 <p>11 X2 ▪ Drawer Left Panel</p>	 <p>12 X2 ▪ Drawer Right Panel</p>

<p>13</p>  <p>X2</p> <p>▪ Drawer Bottom Panel</p>	<p>14</p>  <p>X2</p> <p>▪ Drawer Back Panel</p>	<p>15</p>  <p>X4</p> <p>▪ Drawer Connect</p>	<p>16</p>  <p>X6</p> <p>▪ Studs</p>
<p>17</p>  <p>▪ Rotating Structure</p>	<p>18</p>  <p>X2</p> <p>▪ Support Tube</p>	<p>19</p>  <p>▪ Big Table Top</p>	
<p>20</p>  <p>▪ Back Structure</p>	<p>21</p>  <p>▪ Front Structure</p>	<p>22</p>  <p>▪ Short Connect Tube</p>	<p>23</p>  <p>▪ Long Connect Tube</p>
<p>24</p>  <p>▪ Small Table Top</p>		<p>25</p>  <p>▪ Big Side Panel</p>	<p>26</p>  <p>X2</p> <p>▪ Support Structure</p>
<p>27</p>  <p>X2</p> <p>▪ Caster</p>			

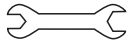
▪SCREWS LIST

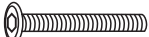
PART	QTY.	ITEM		PART	QTY.	ITEM	
A	24	3X15 MM		I	6	6X25 MM	
B	24	6X40 MM		J	6	M6	
C	16	4X14 MM		K	4	Φ 16MM	
D	20	6X15 MM			1		
E	8	4X35 MM			1		
F	4	6X20 MM			1		
G	4	6X40 MM					
H	6	6X50 MM					

HOW TO ASSEMBLE USING BOLTS AND CAM LOCKS:

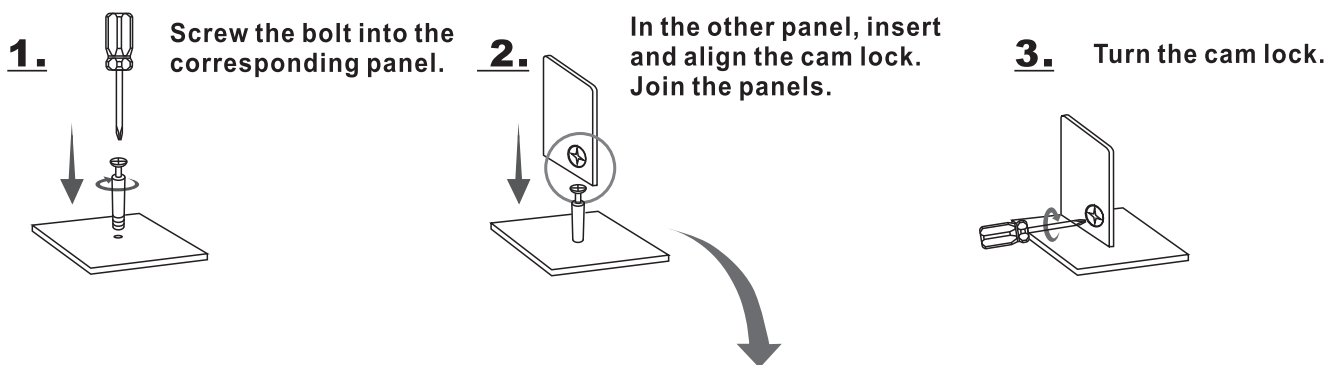

If the panel already comes with the cam lock inserted, make sure is aligned:

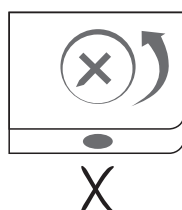

MISALIGNED:
TURN CAM LOCK
TO POINT TOWARDS
THE HOLE

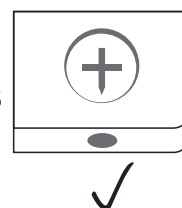

CORRECT



GENERAL ASSEMBLY TIPS AND TROUBLESHOOTING DURING ASSEMBLY:

- *Before you start assembling, make sure you have all the parts and necessary hardware by doing a quick inventory.**
- *Follow the assembly instructions step by step, and do not skip any unless advised to do so by RTA PRODUCTS' Customer Service.**
- *On each step, and to avoid misalignments, always leave screws loose, and do not tighten them until all are in place.**
- *In wood panels, the laminate might be covering the holes.**
If there are no visible holes: Pass the tip of your finger around the area where the hole should be, and press against the surface to feel the indentation.
If the hole looks too small for the screw or bolt: carefully perforate the laminate with the tip of a pen.

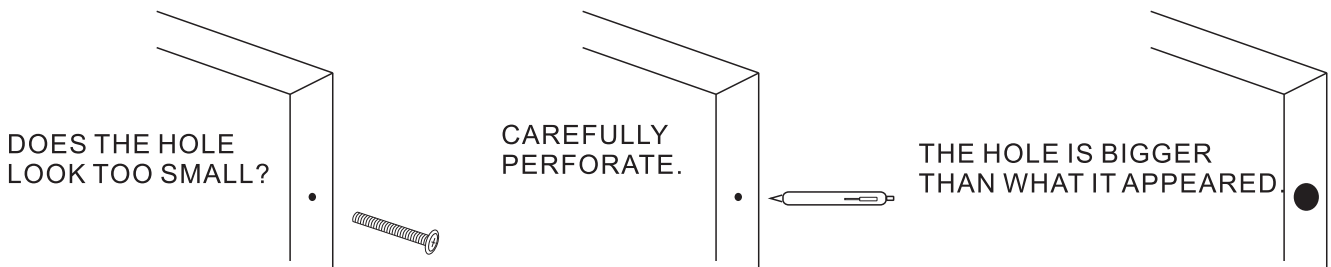

- *In wood panels, some might have inserts that look like screws. Those inserts are either nuts or cam locks. Make sure they are aligned to receive the screws or bolts.**

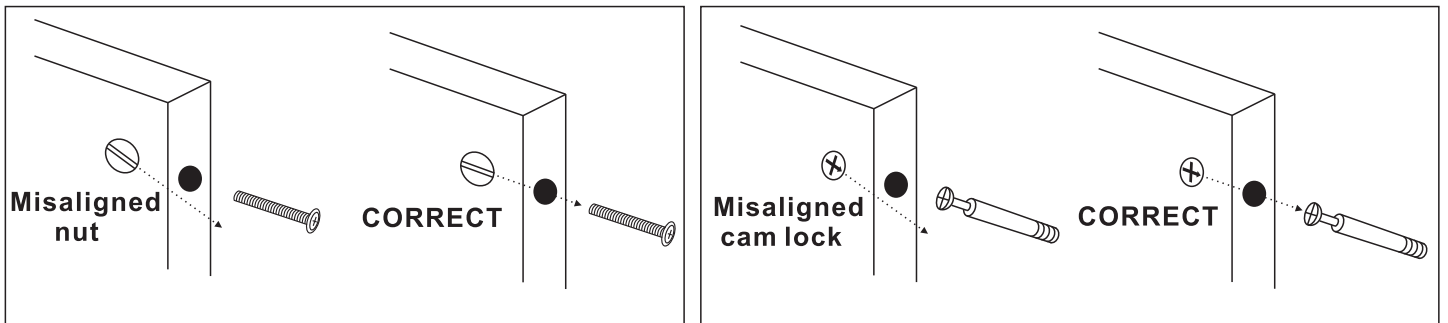

- *Make sure to use the correct screws or bolts, and do not overtighten them. Using wrong screws or overtightening them might cause damage to the parts, and such damage is not covered by the product's warranty.**

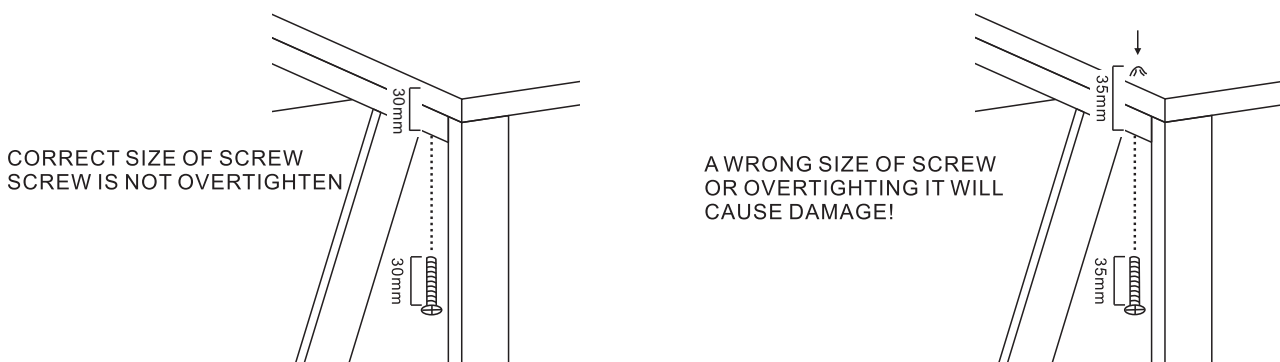

▪ ASSEMBLY STEPS:

1

▪ Use screws A to assemble the Drawer Connects (15) to the Drawer Left and Right Panels (11 & 12).

▪ SCREWS

A 3X15 MM

4PCS

2

▪ Use screws D to assemble the Drawer Connects (15) to the Top Drawer Front Panel and Bottom Drawer Front Panel (9 & 10).

▪ SCREWS

D 6X15 MM

2PCS

3

▪ Slide in the Drawer Bottom Panel (13). Use screws E to assemble the Drawer Back Panels (14) to the Drawer Left and Right Panels (11 & 12).

▪ SCREWS

E 4X35 MM

4PCS

4

▪ Grab the 2 sets of the Drawer Sliders (8) and separate the flat ones from the "L" shaped ones. Place the drawer upside-down as shown and use screws A to assemble the "L" shaped Sliders to the Drawer Left & Right Panels (11 & 12) as shown. **IMPORTANT: REFER TO THE DRAWINGS FOR THE CORRECT POSITION OF THE SLIDERS.** If they get installed incorrectly, the drawers will raise 1" with a gap at the bottom and the top drawer will not close!

REPEAT STEP 3 TO 4 FOR THE OTHER DRAWER

▪ SCREWS

A 3X15 MM

4PCS

5

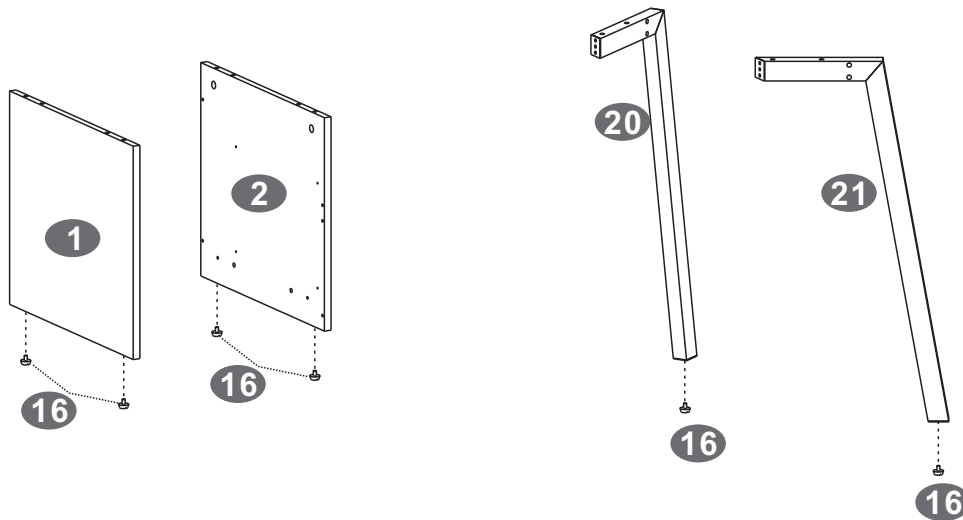

▪ Insert the Studs (16) to the Left Panel, Right Panel, Back Structure and Front Structure (1,2,20 & 21).

6

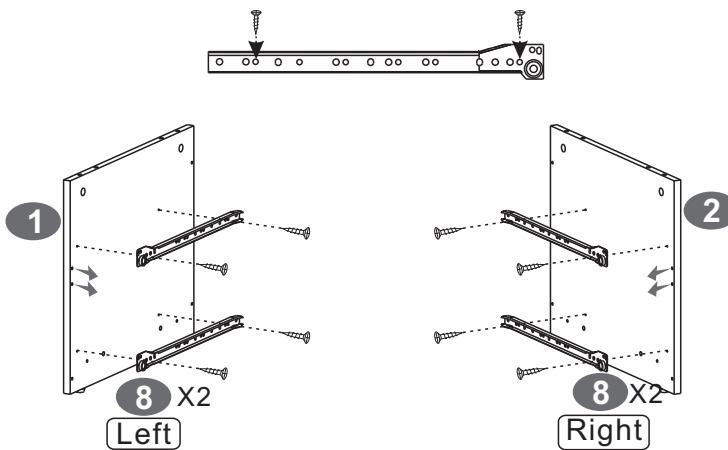

▪ SCREWS

A 3X15 MM

8PCS



▪ Grab 2 sets of the Flat Sliders (8) and use screws A to assemble them to the Left & Right Panels (1 & 2) as shown. The wheel on the sliders go facing to the FRONT and the screw goes on the hole after the wheel as shown. Please pay attention to the direction of the panles.

7

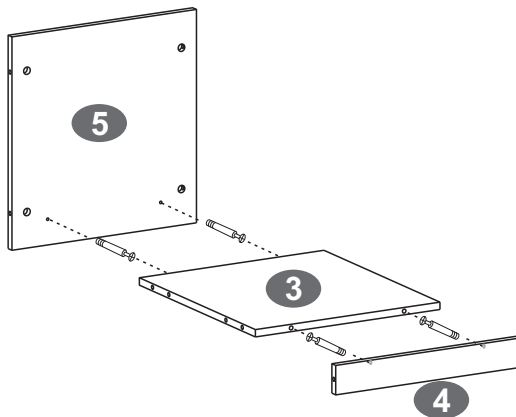

▪ First screw bolts B to the Bottom Front Panel and Back Panel (4 & 5), then assemble the Bottom Panel (3) as shown and as explained in page 5.

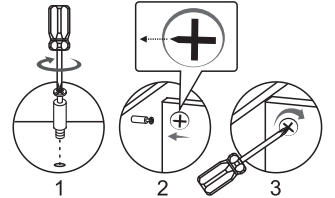

▪ SCREWS

B 6X40 MM

4PCS



8

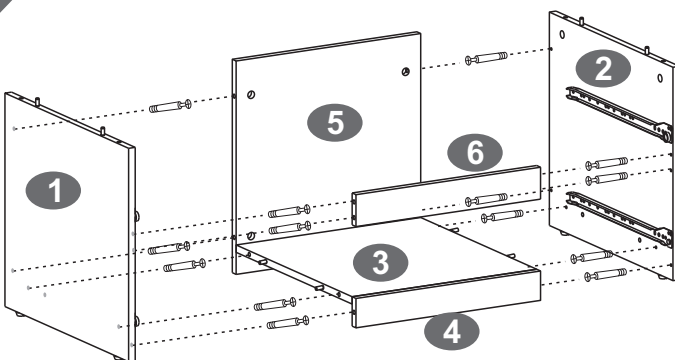

▪ First screw bolts B to the Left Panel (1) and Right Panel (2), then assemble the Bottom Panel, Bottom Front Panel, Back Panel and Middle Front Panel (3,4,5 & 6) as shown and as explained in page 5.

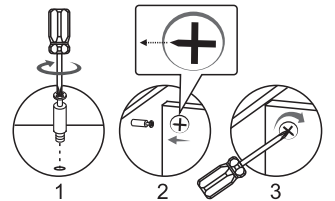

▪ SCREWS

B 6X40 MM

14PCS



9

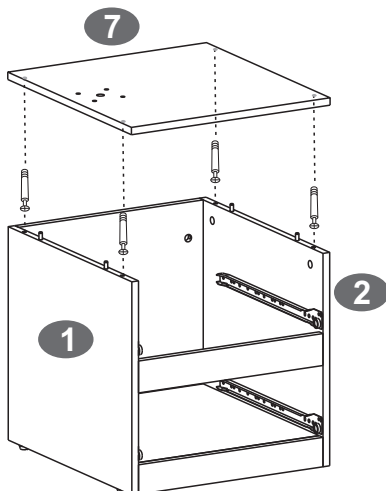

▪ First screw bolts B to the Top Panel (7), then assemble it to the Left and Right Panel (1 & 2) as shown and as explained in page 5.

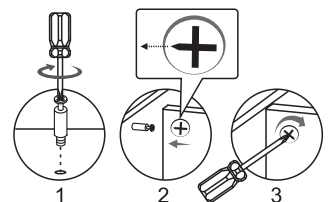

▪ SCREWS

B 6X40 MM

4PCS



10

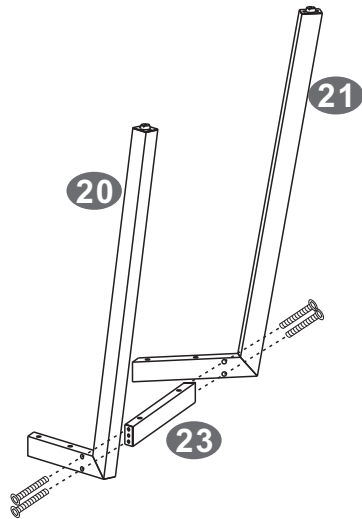

- Use screws G to assemble the Long Connect Tube (23) to the Back Structure and Front Structure (20 & 21).

▪ SCREWS

G 6X40 MM

 4PCS



11

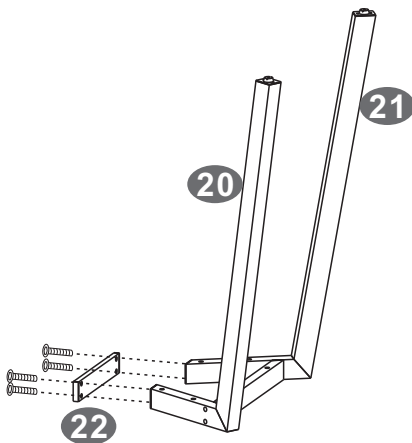

- Use screws F to assemble the Short Connect Tube (22) to the Back Structure and Front Structure (20 & 21).

▪ SCREWS

F 6X20 MM

 4PCS



12

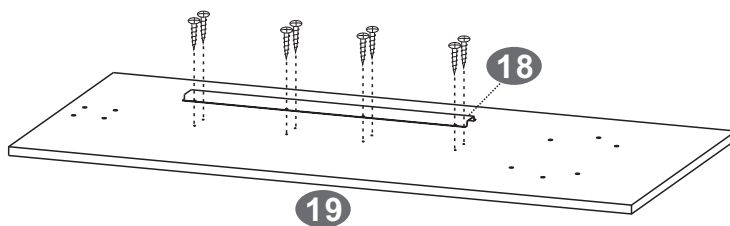

- Use screws C to assemble the Support Tube (18) to the Big Table Top (19).

▪ SCREWS

C 4X14 MM

 8PCS



13

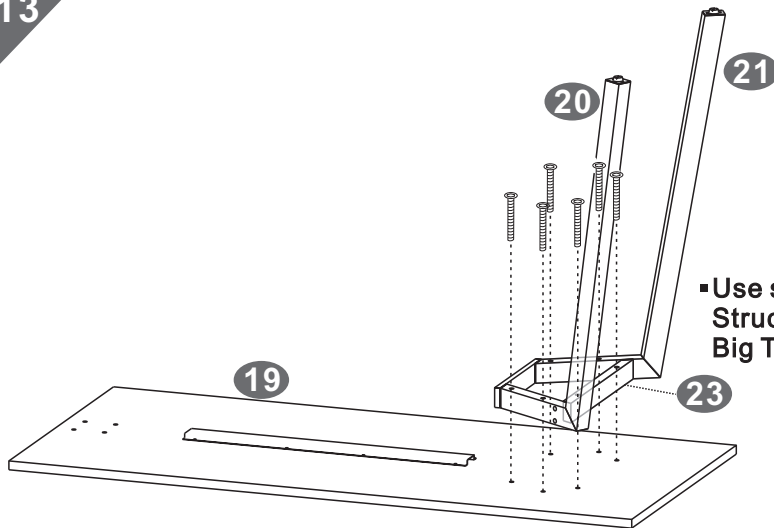

▪ Use screws H to assemble the Back Structure, Front Structure and Long Connect Tube (20,21 & 23) to the Big Table Top (19).

▪ SCREWS

H 6X50 MM

 6PCS



14

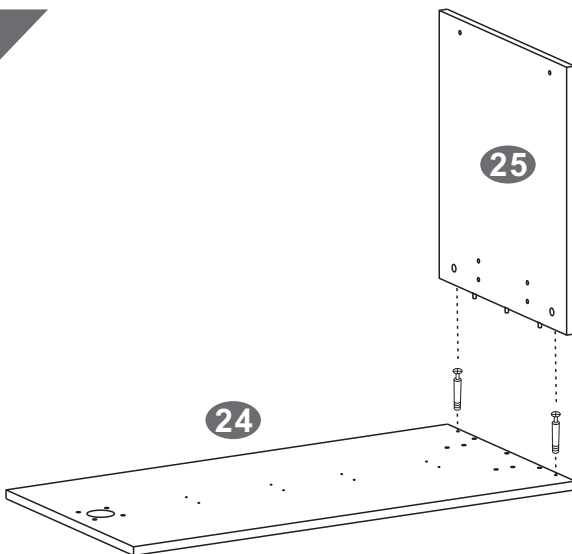

▪ First screw bolts B to the Small Table Top (24), then assemble it to the Big Side Panel (25) as shown and as explained in page 5.

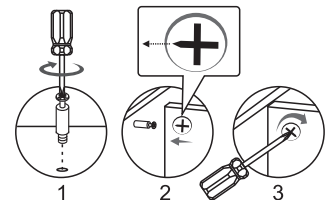

▪ SCREWS

B 6X40 MM

 2PCS



15

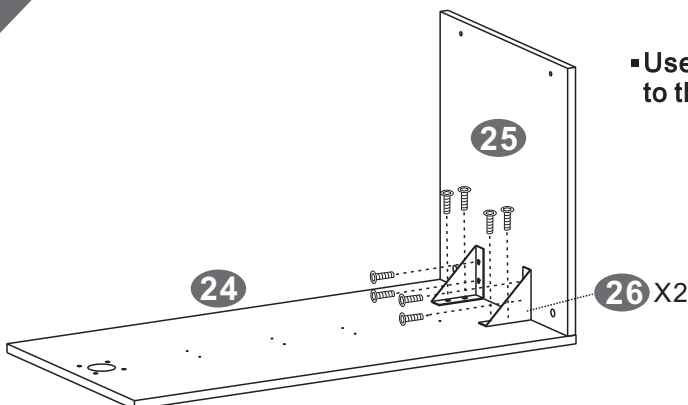

▪ Use screws D to assemble the Support Structures (26) to the Small Table Top and Big Side Panel (24 & 25).

▪ SCREWS

D 6X15 MM

 8PCS



16

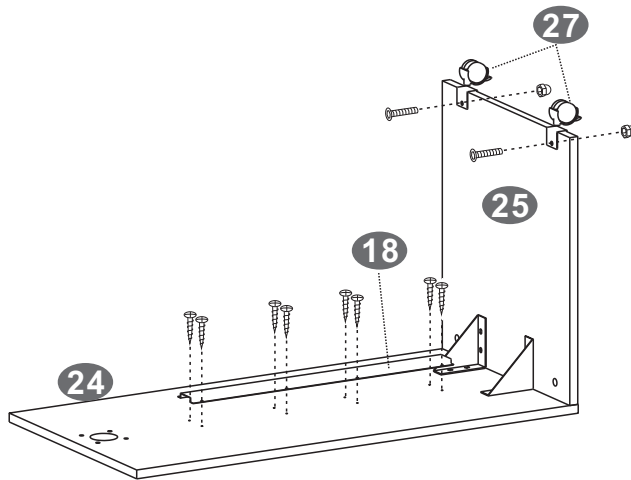

SCREWS

C 4X14 MM

8PCS



I 6X25 MM

2PCS



J M6

2PCS



Use screws C to assemble the Support Tube (18) to the Small Table Top (24). Use screws I & J to assemble the Casters (27) to the Big Side Panel (25).

17

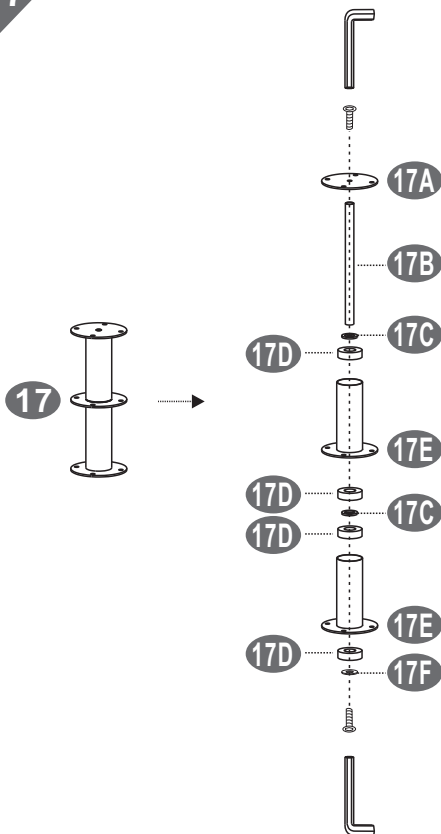

Use Allen Wrench to disassemble the Rotating Structure (17) as shown.
NOTE: It is recommended to keep all the parts for (17) laid out in the same order shown above for easy re-assembly later.

18

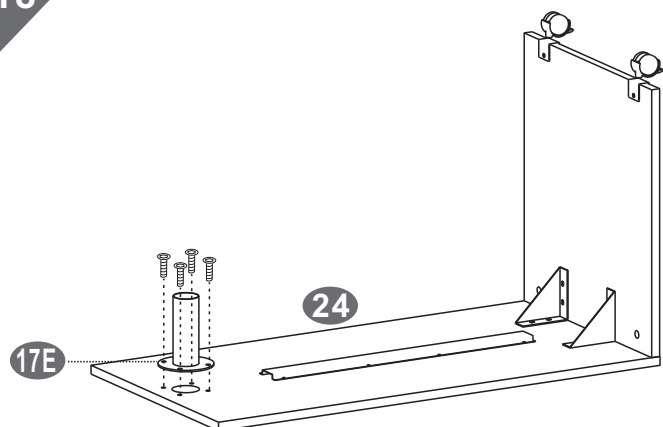

Use screws D to assemble one of the part 17E to the Small Table Top (24).

SCREWS

D 6X15 MM

4PCS



19

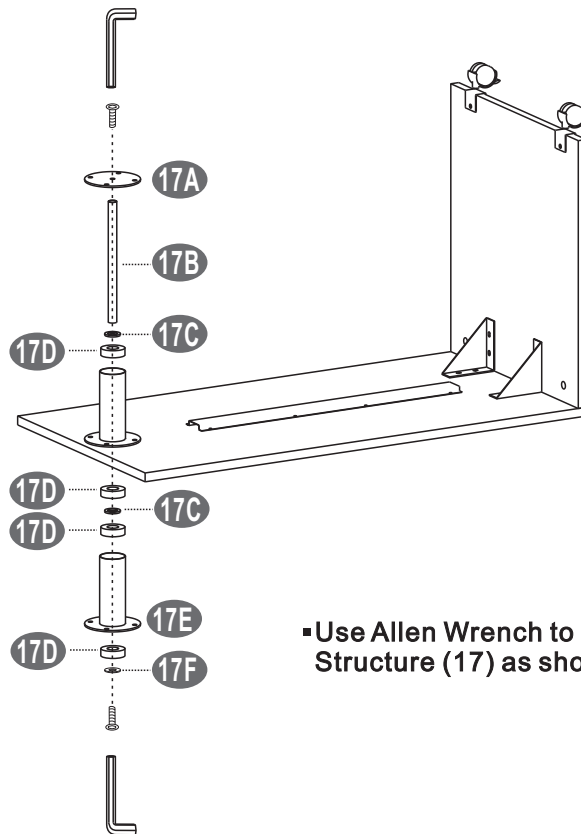

▪ Use Allen Wrench to assemble the Rotating Structure (17) as shown.

20

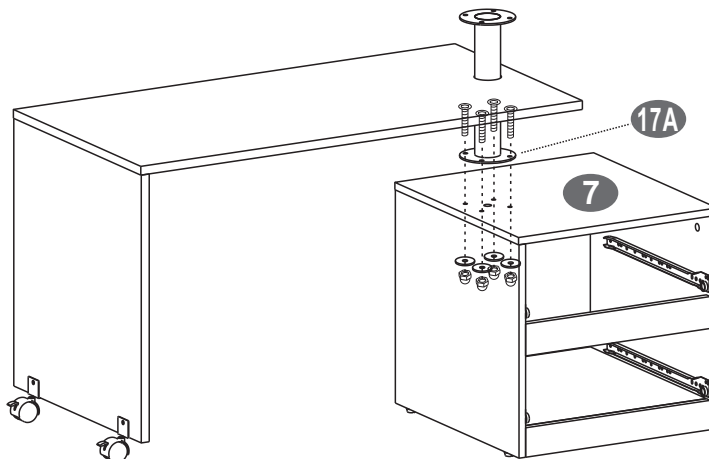

▪ Use screws I, J & K to assemble the Rotating Structure (17) to the Top Panel (7) as shown.

▪ SCREWS

I 6X25 MM

 4PCS



J M6

 4PCS



K Φ 16 MM

 4PCS

21

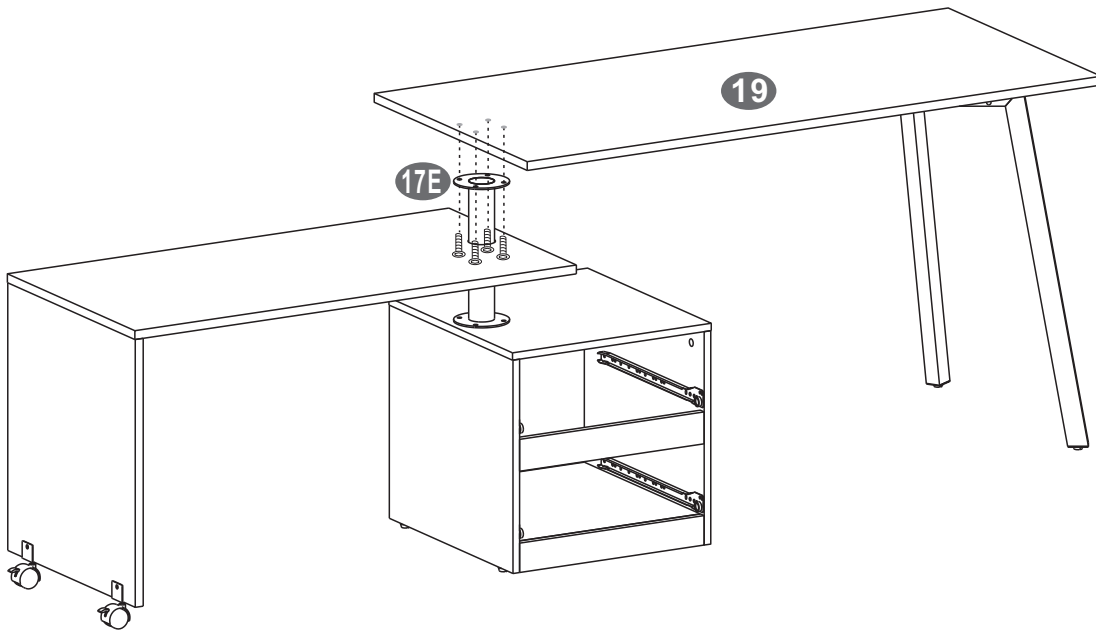

▪ Use screws D to assemble the Rotating Structure (17) to the Big Table Top (19).

▪ SCREWS

D 6X15 MM

 4PCS



22

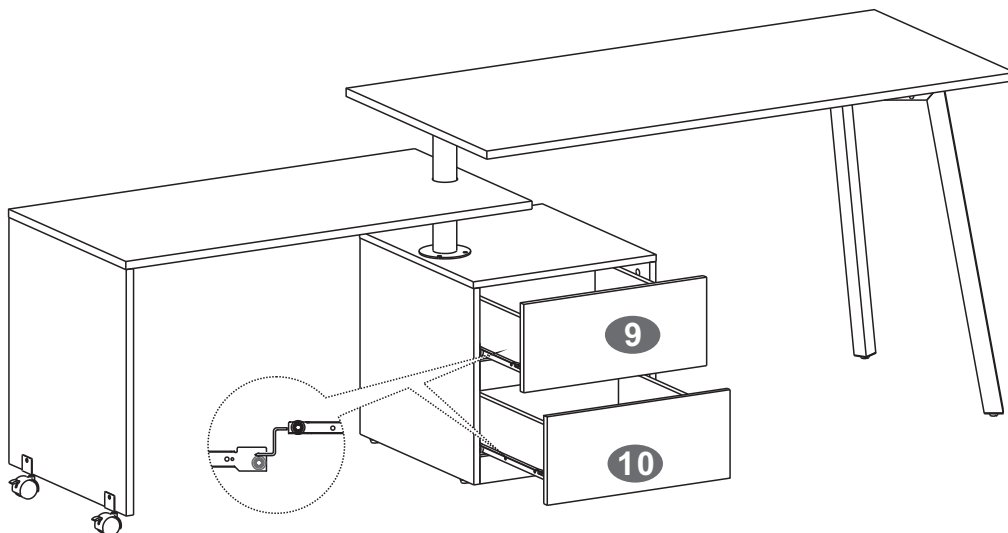

▪ Tighten any and all screws.
 Insert the drawers into the cabinet, starting with the bottom drawer.
 You might have to insert it at a downward tilted angle.

CARE AND MAINTENANCE

English

- DO NOT EXPOSE THE SURFACES TO DIRECT SUNLIGHT OR EXTREME ENVIRONMENTAL CONDITIONS. ANY DAMAGE RESULTING FROM SUCH EXPOSURE IS NOT COVERED BY THE PRODUCT'S WARRANTY.
- THE PREFERABLE METHOD TO CLEAN THE SURFACES IS TO WIPE THEM USING A SOFT CLOTH DAMPENED WITH A SOLUTION SOAP AND WATER, THEN DRY WITH A CLEAN TOWEL.
- DO NOT SPRAY SOLVENTS OR CLEANING AGENTS DIRECTLY OVER THE SURFACES, STRUCTURAL TUBES OR METAL PARTS.
- DO NOT LEAN, SEAT OR STAND OVER THE UNIT.
- DO NOT ALLOW CHILDREN TO PLAY OVER/UNDER THE UNIT, NOR ALLOW THEM TO REACH INSIDE ANY COMPARTMENTS WITHOUT THE SUPERVISION OF AN ADULT.
- BEFORE MOVING OR TRANSPORTING THE UNIT, MAKE SURE THAT:
 - ALL HEAVY OBJECTS OR THAT MIGHT FELL OFF ARE REMOVED FROM THE UNIT.
 - IF THE UNIT ARE ON CASTERS (WHEELS), MAKE SURE THAT ALL ARE UNLOCKED.
 - THE UNIT MUST BE HANDLED BY AT LEAST 2 PERSONS.
 - WHEN LIFTING THE UNIT, USE BOTH OF YOUR HANDS, AND BEND YOUR KNEES. REMEMBER TO ALWAYS LIFT WITH YOUR LEGS, NOT YOUR BACK.
- IN CASE OF DAMAGE TO ANY PARTS, NOTIFY THE VENDOR AS SOON AS POSSIBLE.
- IN CASE OF GLASS BREAKAGE (IF THE UNIT HAS A GLASS TABLE TOP OR PARTS MADE OF GLASS) DO NOT HANDLE THE BROKEN GLASS WITH YOUR BEAR HANDS, AND CONTACT THE VENDOR IMMEDIATELY. DO NOT ALLOW CHILDREN NEAR THE BROKEN GLASS.