

## MODEL RTA-2018

### ASSEMBLY INSTRUCTIONS

▀ *Assembly video also available online at [technimobili.com](http://technimobili.com)*

Thank you for purchasing one of our products.  
Please read carefully the assembly instructions before the installation.  
Do not discard this manual or any of the packaging material until the unit has been completely assembled.

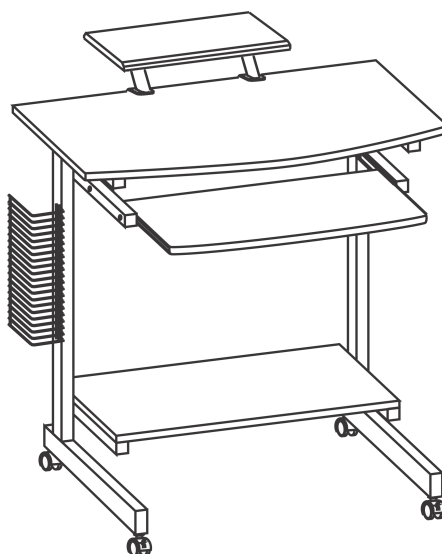



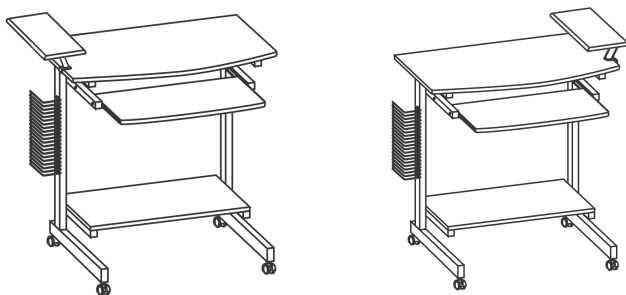





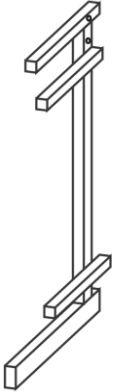

#### With adjustable shelf

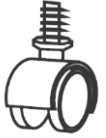

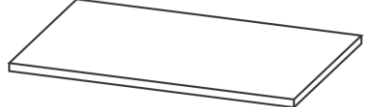
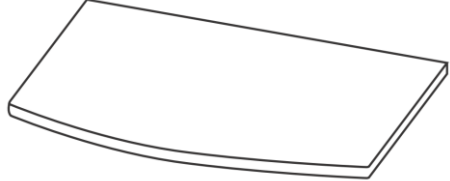
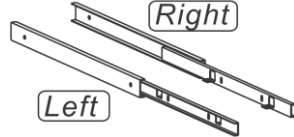
By







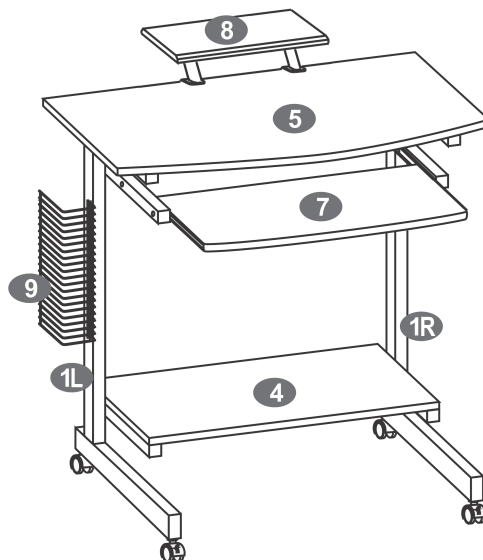

MAIN PARTS LIST

<p><b>1L</b> x1</p> <p>Left structure</p> 	<p><b>1R</b> x1</p> <p>Right structure</p> 	<p><b>2L</b> x2</p> <p>Locking Caster</p> 	<p><b>2N</b> x2</p> <p>Non-Locking Caster</p> 	
		<p><b>3</b> x1</p> <p>Back panel</p> 	<p><b>4</b> x1</p> <p>Lower panel</p> 	
<p><b>5</b> x1</p> <p>Main panel</p> 		<p><b>6</b> x1</p> <p>Keyboard slider SET</p> 	<p><b>7</b> x1</p> <p>Keyboard panel</p> 	
<p><b>8</b> x1</p> <p>Printer/Monitor panel</p> 	<p><b>9</b> x1</p> <p>CD holder</p> 	<p><b>10A</b> x2</p> <p>Support tube</p> 	<p><b>10B</b> x2</p> <p>Protection clip</p> 	<p><b>10C</b> x2</p> <p>Screw knob</p> 

MAIN PARTS LAYOUT (For reference)



## SCREWS LIST

PART	QTY	SIZE / DESCRIPTION	FIGURE
A	4	6x45mm	
B	8	6x30mm	
C	6	6x12mm	
D	8	4x12mm	
	1	Hex Wrench	
	1	Allen Wrench Hex/Phillips	

## BEFORE YOU START THE ASSEMBLY, PLEASE READ THE FOLLOWING TIPS AND WARNINGS.

- Do a quick inventory to make sure the product contains all the parts and hardware.
- Missing, damaged and defective parts can be replaced at no cost to you. Please refer to the CONTACT card included with the product.
- The replacement parts service is limited to the continental United States. If you reside in Hawaii, Puerto Rico, U.S. Dependencies or other countries, please contact the supplier from where the unit was purchased.
- If during assembly you find an issue or need clarification, please contact our Customer Service for assistance. Please refer to the CONTACT card included with the product.
- On each step read the instructions and analyze the illustrations thoroughly before proceeding to do the assembly.
- Make sure you understand which hardware will be used on each step. Using the wrong size of screw, bolt or pin might strip the threads or cause damage to the part in which it is being used.
- To avoid misalignments, always leave the screws loose and tighten them until all pieces are positioned correctly.
- Do not overtighten or force the screws as they might break, strip, damage the threads of the holes or get stuck inside the part.
- Sometimes the laminate might cover partially or entirely the hole on a panel, but the hole should still be located under the laminate.
- If there is no visible hole for the screw, pass and press the tip of your finger over the area where the hole should be located to feel the indentation, and once found, carefully pierce the laminate to reveal the hole underneath.
- If the hole seems too small for the screw, first make sure you are using the correct size of screw and that it's been installed in the correct hole. If the hole still appears to be too small, carefully pierce the laminate to reveal the hole's actual size.

ASSEMBLY STEPS

STEP 1



Using the wrench, assemble the casters ② to the structures ①L, ①R in the following order:

- The locking casters ②L go on the *front* bottom holes,
- The non-locking casters ②N go on the *back* bottom holes.

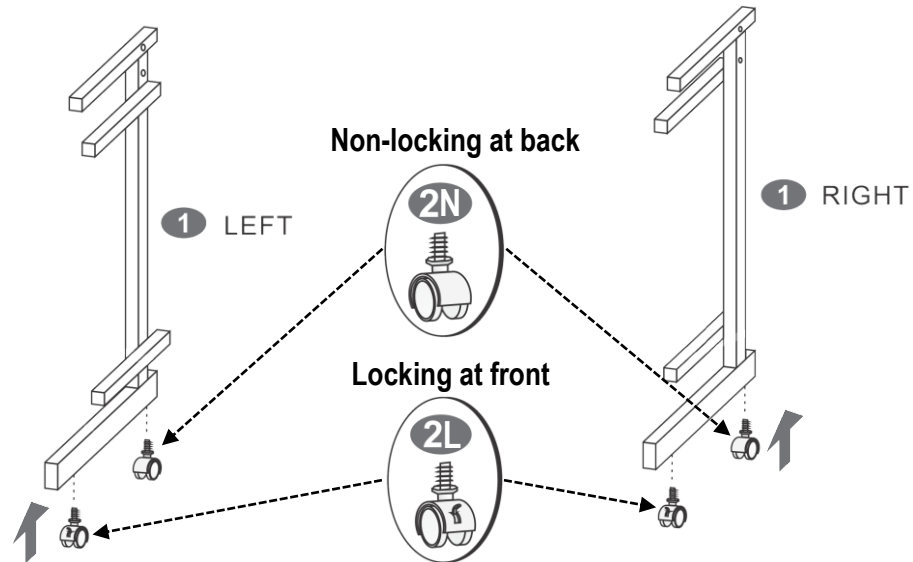

STEP 2

Screws:

A	6x45mm	4
		Pcs

Panel ③ comes with metal inserts on its interior face, they look like screws but are nuts pre-aligned to receive the screws. Sometimes misalignments occur, and you will have to use a flat head screwdriver (not included) to turn and align the inserts as shown below.

First check and make sure of the correct alignment of the inserts in the back panel ③, then use screws A to assemble it to the structures ①L and ①R as shown.

If the inserts are misaligned, use a flat head screwdriver to re-align them.

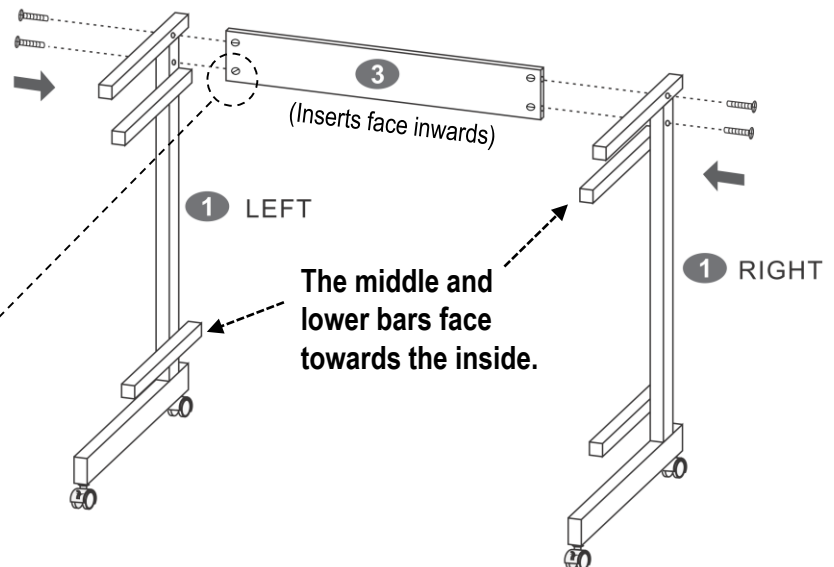
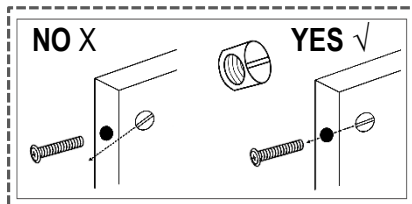

**STEP 3**

Use screws **(B)** to assemble the lower panel **(4)** to the lower bars on the structures **(1)L**, **(1)R** from underneath as shown.

**Screws:**

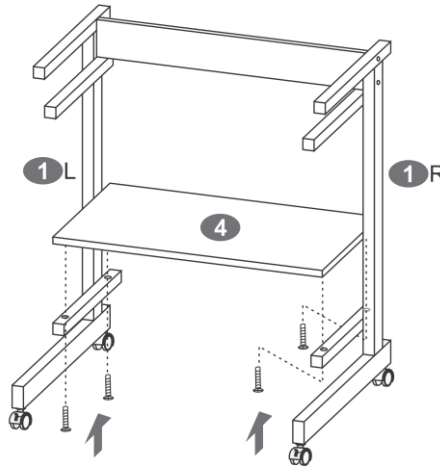

**STEP 4**

Use screws **(B)** to assemble the main panel **(5)** to the top bars of the structures **(1)L** and **(1)R** from underneath as shown.

**Screws:**

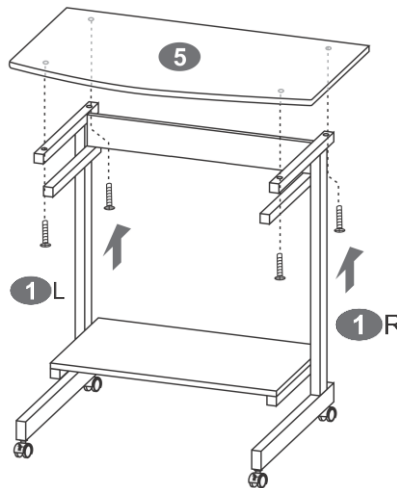

**STEP 5**

Use screws **(D)** to assemble the keyboard sliders **(6)** on their respective sides to the middle bars of the structures **(1)L** and **(1)R** from the inside. The screws have to go thru the sliders' holes and insert into the holes on the structures as shown.

**Screws:**

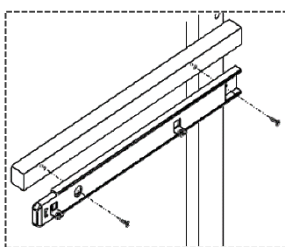
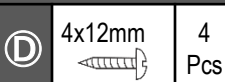

The tabs face down

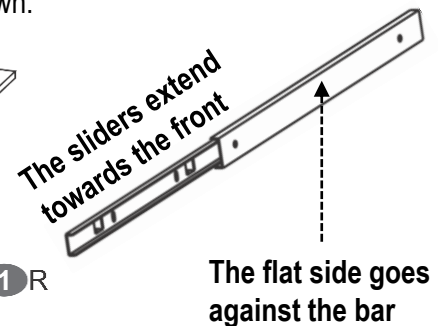
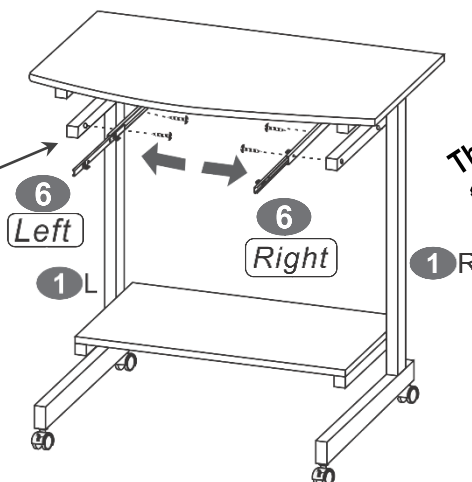

**STEP 6**

Use screws ④ to assemble the keyboard panel ⑦ to the sliders ⑥ from underneath as shown.

**Screws:**

④	4x12mm	4 Pcs
---	--------	-------

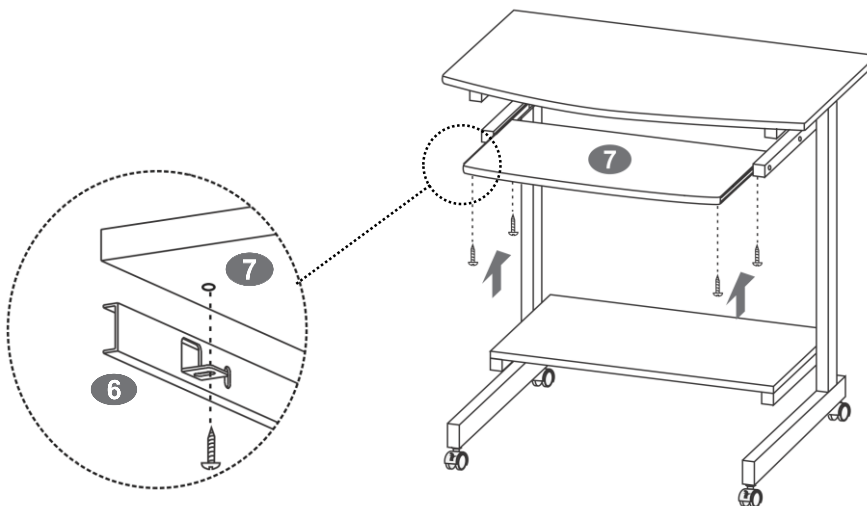

**STEP 7**

Use screws ③ to assemble the CD rack ⑨ to either structure ①L or ①R according to your preference.

**Screws:**

③	6x12mm	2 Pcs
---	--------	-------

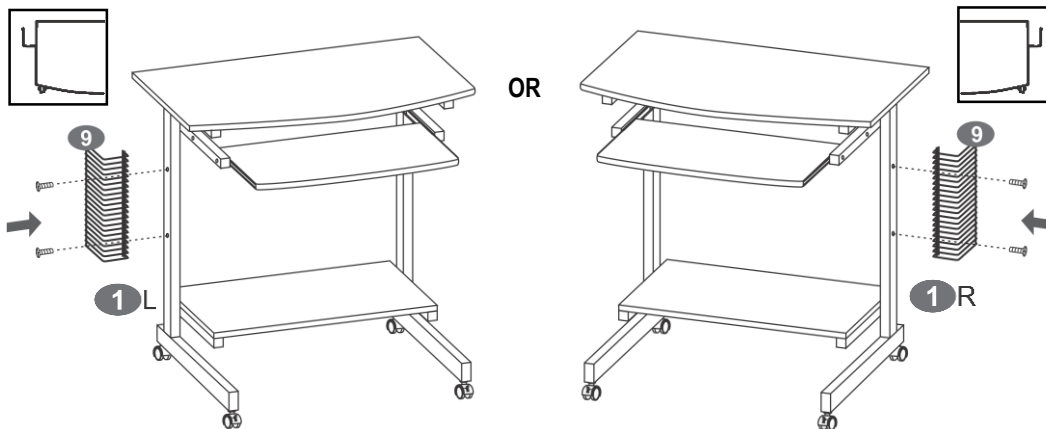

**STEP 8**

Use screws ③ to assemble the support tubes ⑩A to the monitor/printer panel ⑧ as shown.

**Screws:**

③	6x12mm	4 Pcs
---	--------	-------

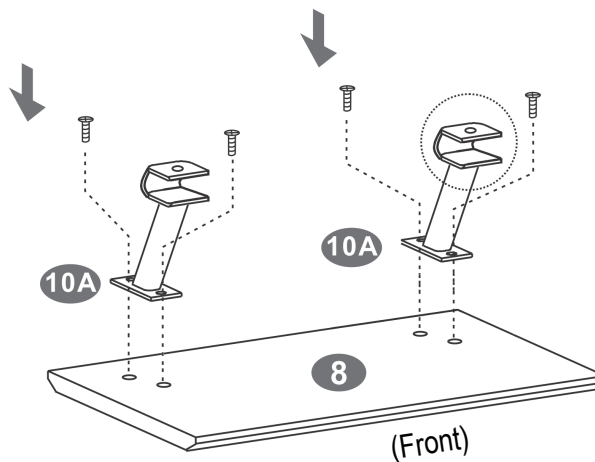

## STEP 9

Assemble the support tubes ⑩A to the main panel ⑤ in the position of your preference making sure that the protection clips ⑩B are positioned in between, then use the screw knobs ⑩C to secure the tubes as shown.

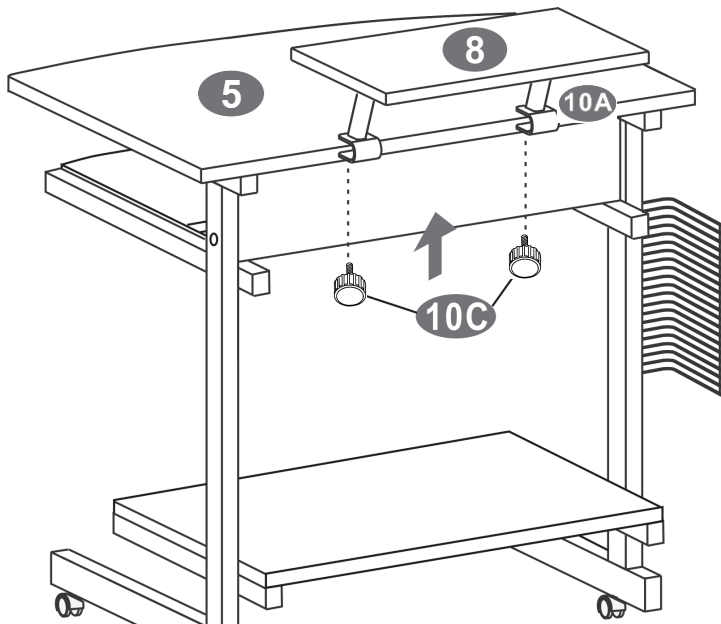

(This view is from the back side)

The clips ⑩B go in between the tubes and the main panel.

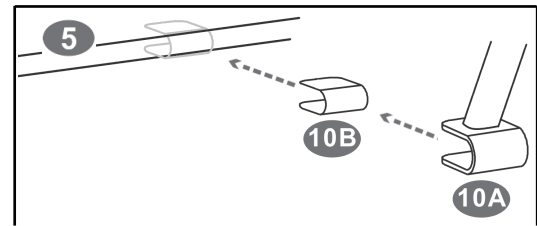

ON THE BACK:

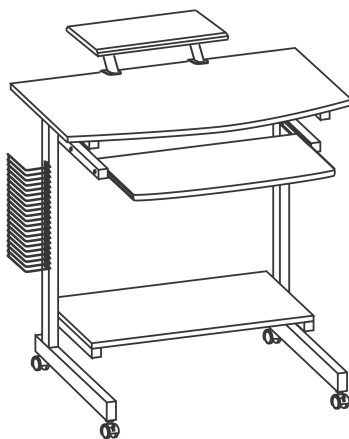

ON THE LEFT:

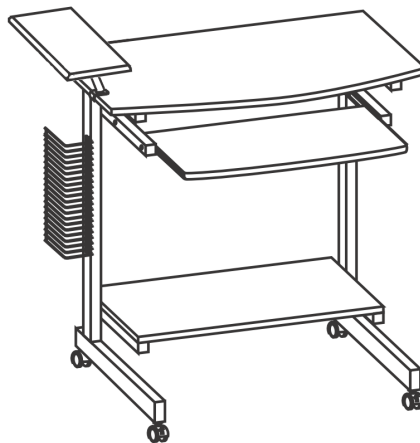

ON THE RIGHT:

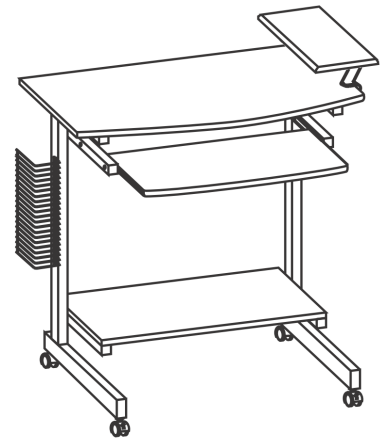

**ALL DONE!** Before you start using the unit, make sure that all the screws, bolts, cam locks, etc. are properly tightened, and read all the warnings in the next page.

**AFTER THE ASSEMBLY IS DONE, PLEASE READ CAREFULLY THE FOLLOWING CARE AND MAINTENANCE WARNINGS:**

**WEIGHT LIMITS**

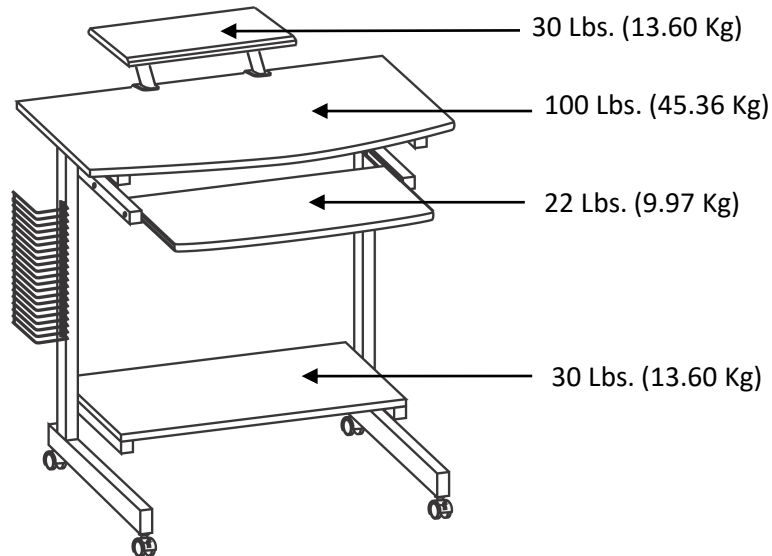

- Do not exceed the indicated weight limits.
- Do not expose the surfaces to direct sunlight or to extreme environmental conditions.
- Clean the surfaces preferable with a clean cloth damped in a solution of mild soap and water, then dry with a clean towel.
- Do not use solvents or abrasive materials to clean the unit.
- If you decide to use a cleaning agent, test first on an area hidden from view such as underneath the main panel.
- Do not seat on the unit or lean against it.
- Do not allow small children to play under or over the unit, nor use it as a moving vehicle.
- Keep the unit with the front casters locked.
- Before moving the unit, make sure to unlock the front casters, and remove any object that might fall off.
- When transporting the unit to places far away, lock the front casters and protect and secure the unit to avoid damage in transit.
- Shall any part of the unit becomes defective during the warranty period, replacement parts might be available to you at no charge. Please refer to the WARRANTY card included with the product.
- The warranty does not extend to regular wear and tear, nor the manufacturer assumes liability for damages or consequences due to accidents, incorrect assembly, negligence, improper use, modifications, or not heeding the above warnings.
- The warranty is limited to the continental United States. If you reside in Hawaii, Puerto Rico, U.S. Dependencies or other countries, please contact the supplier from where the unit was purchased.