

AVIX Autonomic Mark II

User manual - Version 1.0

Package contents:

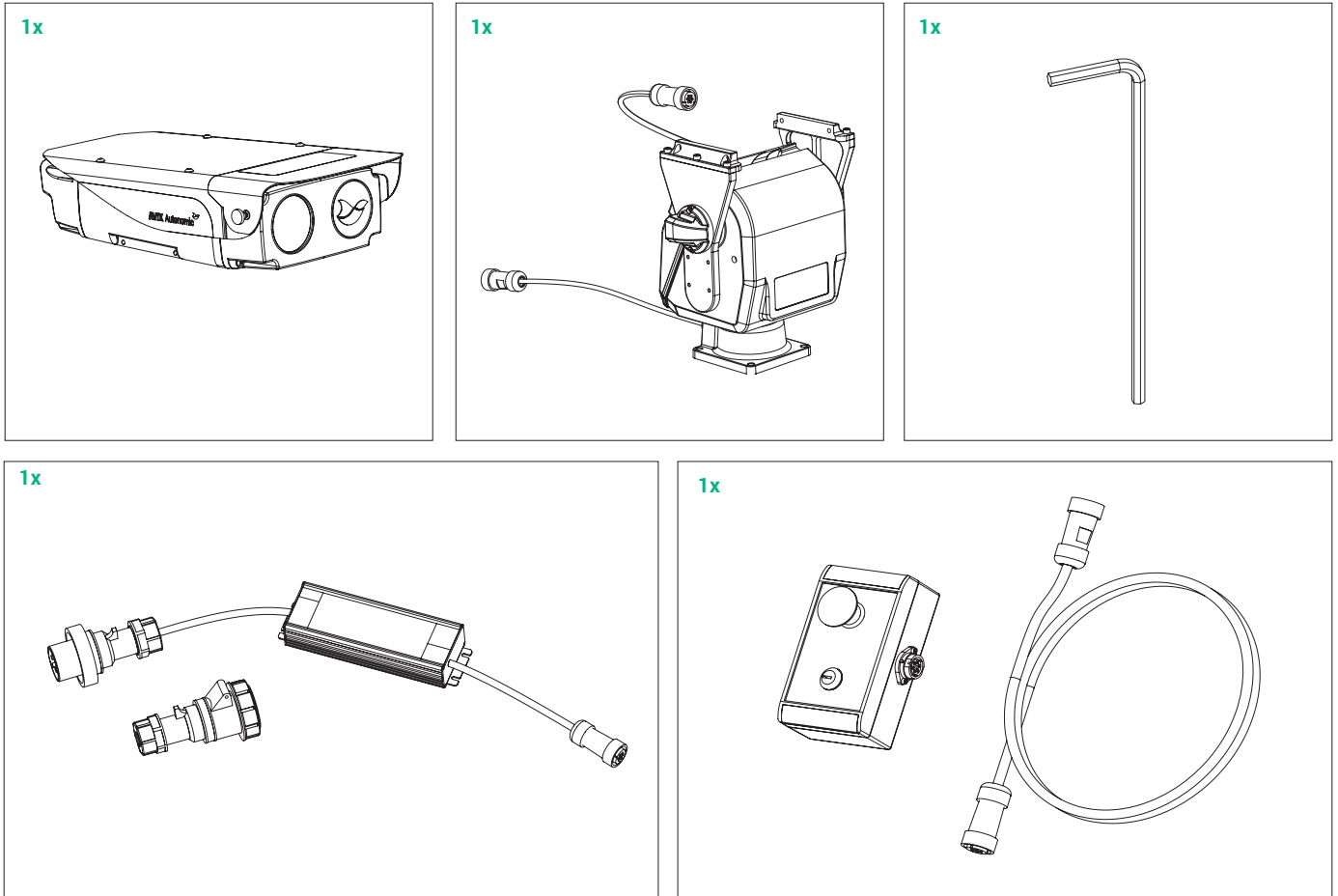

General overview:

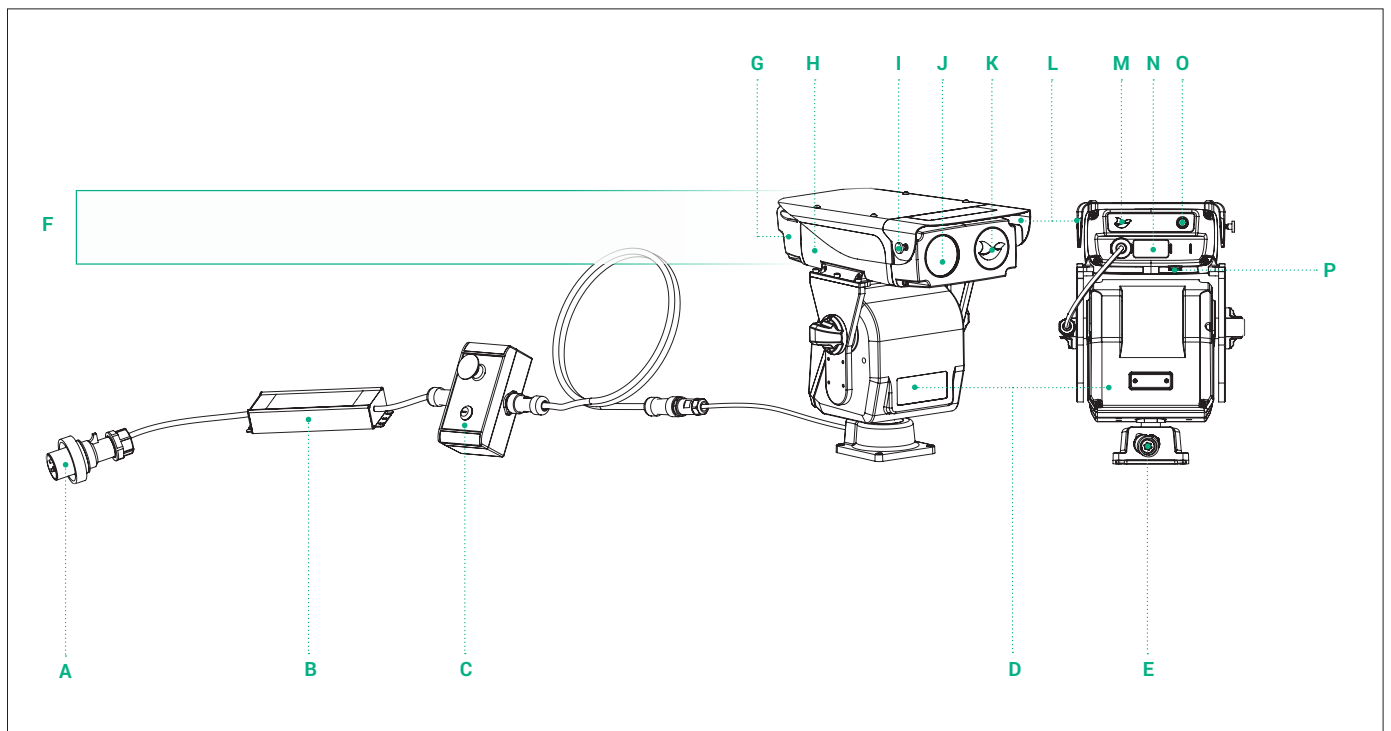

Figure 1.1



Figure 1.2



Assembly:

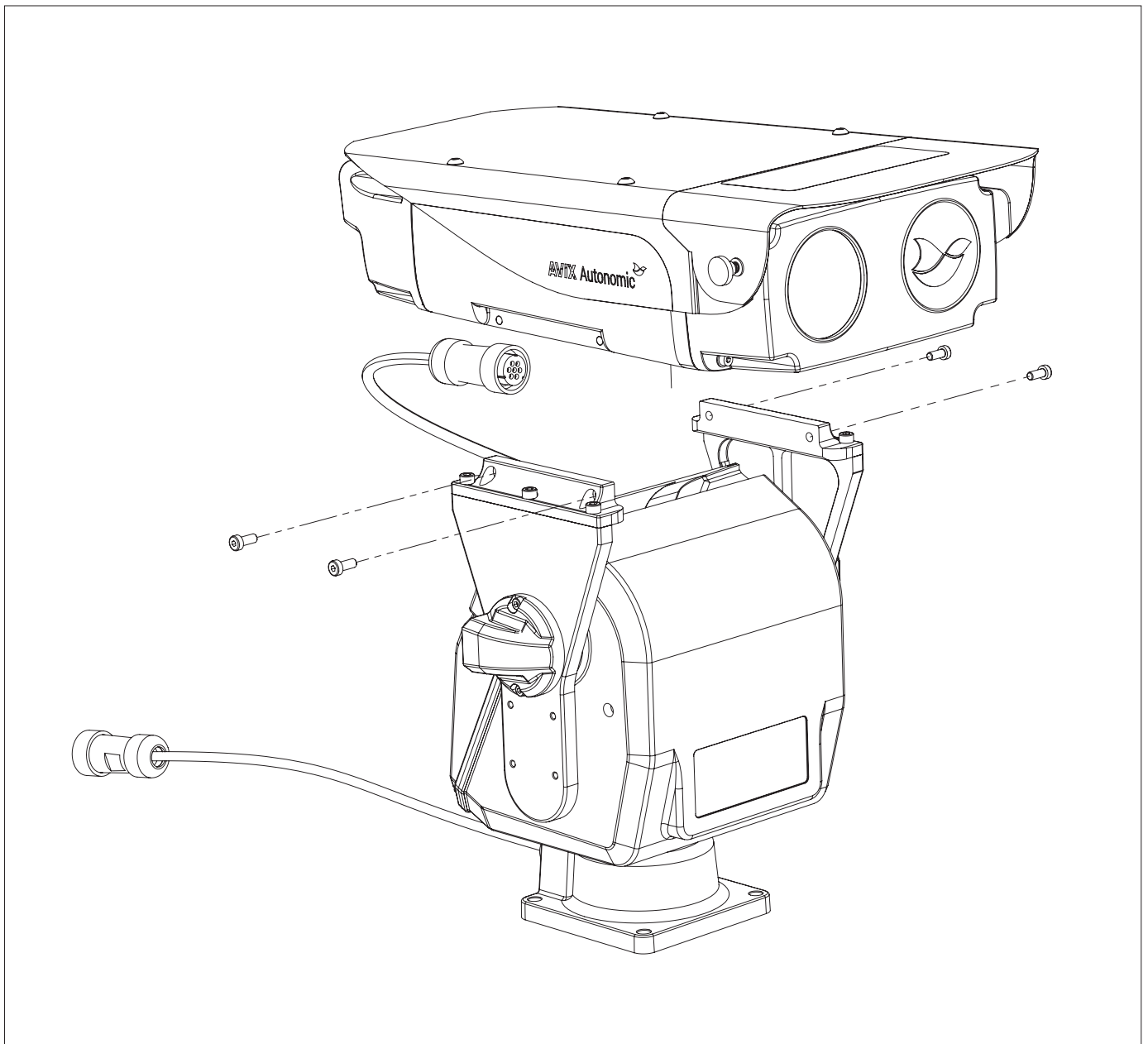

Figure 2.1

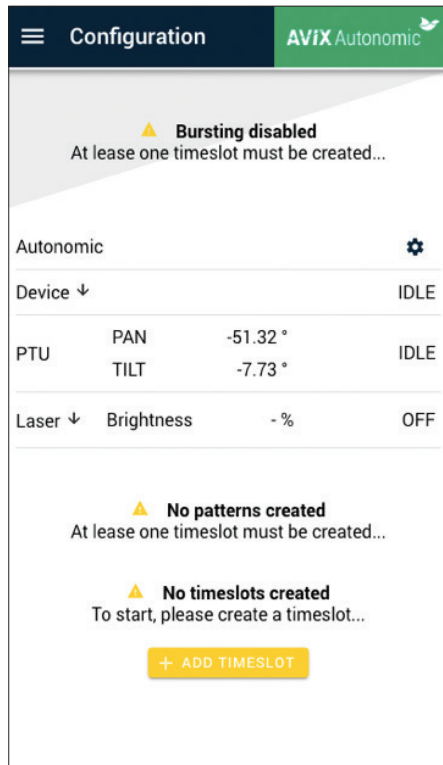

Figure 2.2

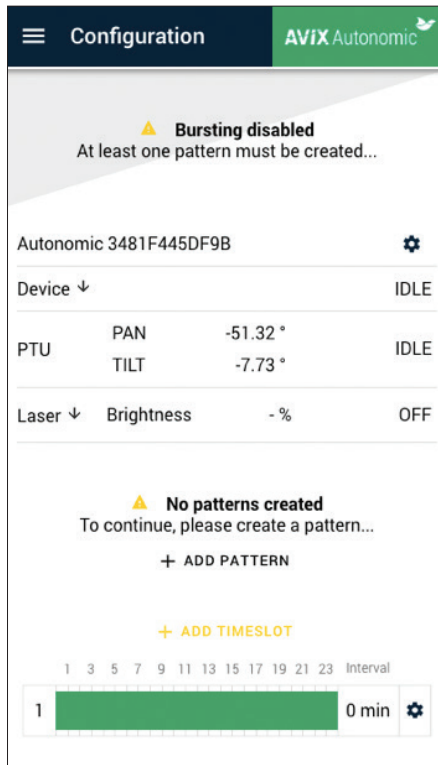

Figure 2.3

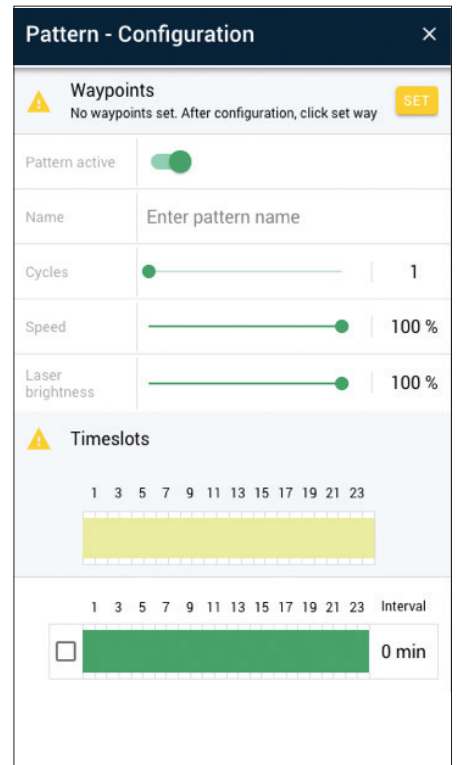

Figure 2.4

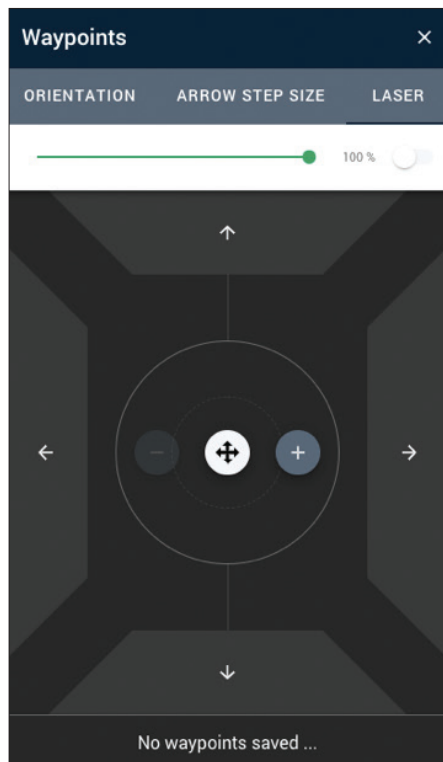
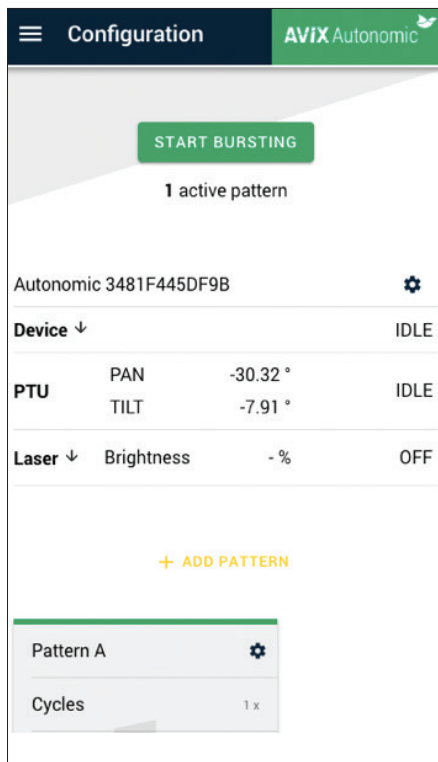

Figure 2.5



Explanation of general view (page 1)

A CEE Plug	I Beam shutter lock
B Mains Power Adapter	J Laser aperture
C Power Switch Module	K Accessory slot
D Motor Platform	L Beam shutter
E Power socket	M LED status indicator ()
F Payload	N Product information tag
G Rear Cap	O ON/OFF button ()
H Light Module (inside Payload)	P USB socket

Table of contents

1. Technical specifications	page 5
2. Safety instructions	page 6
3. Assembly	page 6
4. Configuration	page 7
5. Maintenance	page 9
6. Warranty	page 9
7. Spare parts	page 10
8. Accessories	page 10
9. Troubleshooting	page 10

Thank you for your purchase of the AVIX Autonomic Mark II

The AVIX Autonomic is a fully automated bird repelling system, providing 24/7 bird repelling capability after a one-time configuration. The AVIX Autonomic is a silent, effective and easy-to-use solution for human-bird conflicts. The patented optical technology of the AVIX Autonomic enables long-distance bird repelling. The user manual includes technical specifications, safety instructions and basic configuration information.

Package contents (page 1):

- 1 x AVIX Autonomic Mark II
- 1 x Power Switch Module
- 1 x Key for Power Switch Module
- 1 x Mains Power Adapter
- 1 x Hex Key (3mm)
- 1 x CEE Connector
- 1 x Flight Case

Explanation of signal words

 **WARNING:** Indicates a potentially hazardous situation which, if not avoided, may result in death or serious injury and/or property damage.

 **CAUTION:** Indicates a potentially hazardous situation which, if not avoided, may result in minor or moderate injury and/or property damage.

 The "CE" mark indicates that this product complies with the applicable European Directives which relate to health, safety, environmental and consumer protection.

Bird Control Group is not liable for the misuse of the AVIX Autonomic and/or its accessories. Bird Control Group has no control over the use, care, or maintenance of the AVIX Autonomic once it is in the hands of a user; and as such, accepts no liability for the use or misuse of the AVIX Autonomic. Under no circumstance are Bird Control Group, its partners, suppliers or employees liable for losses, damages or expenses of any kind resulting from: the use, misuse, or abuse of the AVIX Autonomic; or for the user's failure, willful or otherwise, to operate the product in a correct and safe manner.

⚠ WARNING: Carefully read all safety warnings and all instructions. Retain all safety warnings and all instructions for future reference.

⚠ CAUTION: Prior to the initial use of the product, check to determine whether additional laws and regulations are applicable in your country or locale for use of the AVIX Autonomic.

⚠ WARNING: Prior to use, perform a risk assessment of the intended area of use and take precautions or control measures as necessary.

i *If a person experiences direct eye exposure to the laser, this person should visit the assigned company doctor. If no company doctor is assigned, they should bring the applicable laser specifications and visit their own doctor.*

1. Technical specifications

AVIX Autonomic Mark II

Laser

- class	3B
- wavelength	520 nm (green) continuous wave
- maximum output power	<500 mW
- divergence	0.05 mrad
- diameter at aperture	Ø 40 - 50 mm
- NOHD	<2366 m
- MPE	25.4 W/m ² (assumed exposure duration of 0.25 seconds)
Horizontal projection range	360° (continuous)
Vertical projection range	-50° to +30°
Endurance	IP66
Operating temperature*	-15 °C to +50 °C (5 °F to 122 °F)
Safety Features	Laser operating LED indicator and key lock switch (according to EN 60825-1:2014) Emergency stop button Password protection
Power source	Power adapter (100 - 277 VAC)
Operating voltage	24 VDC (@ max. 4A)
Power consumption	100 W (peak operating power)
Weight	11 kg (24 lb.)
Dimensions (L x W x H)	50 (19.7) x 21 (8.3) x 40 (15.8) cm (in)
Compatible devices	Android version 6.0 (or higher) Bluetooth version 4.0 (or higher) Google Chrome installed

* Laser output power may slightly reduce near limits of the operational temperature range

2. Safety instructions

⚠ WARNING: Avoid direct eye exposure to the laser beam. Direct eye exposure to the laser beam and exposure to direct reflections can result in serious eye damage. Exposure of the eye to diffuse reflections is considered safe for the eye.

⚠ WARNING: Viewing the laser output with optical instruments designed for use at a distance (for example, telescopes or binoculars) may pose an eye hazard.

⚠ WARNING: This laser product may only be used in a controlled area and is for professional use only.

⚠ WARNING: The laser beam of the AVIX Autonomic may cause dazzle or after images, particularly under low ambient light conditions. These effects may have indirect safety implications if experienced by users during the performance of safety-critical operations.

⚠ CAUTION:

- The operator of the device must complete a laser safety training before using the AVIX Autonomic.
- The AVIX Autonomic is to be used only by adults.
- The AVIX Autonomic is to be used only for the purpose of repelling birds.
- The Laser module, Rear Cap, Motor Platform and Power Switch Module have no internal user-serviceable parts.

⚠ WARNING: Only operate the product in undamaged condition. Use of a damaged AVIX Autonomic may result in exposure to hazardous laser radiation.

⚠ CAUTION: The images below depict incorrect use of the AVIX Autonomic. For your safety and the safety of others, study these images carefully before operating the AVIX Autonomic.

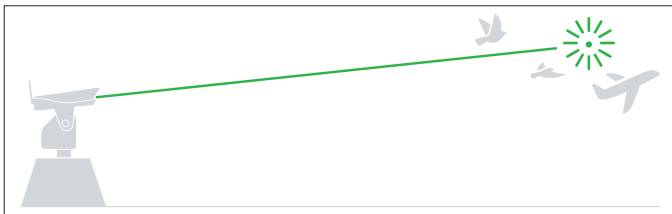

Never project the laser device towards aircraft, vessels and vehicles.

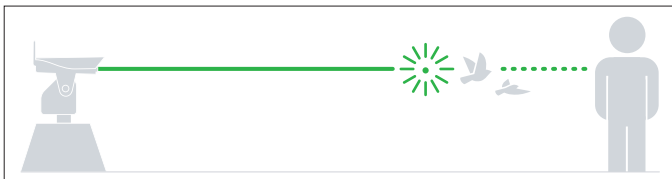

Never project the laser device at humans.

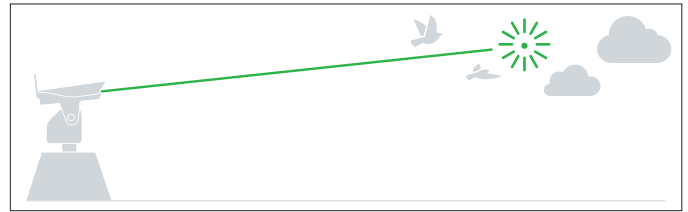

Never project the laser device into the infinite sky.

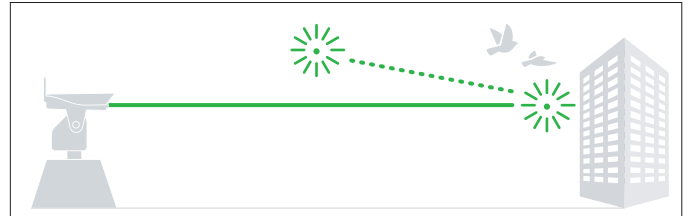

Never project the laser device towards reflective surfaces such as mirrors, windows and metallic objects.

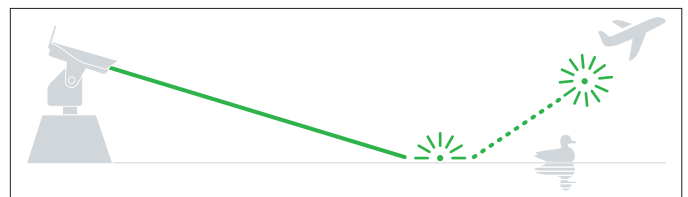

Projecting the laser device towards water can cause distractions.

The laser safety labels depicted in figure 1.1 can be found on top of the beam shutter. The entrapment hazard label depicted in figure 1.2 can be found on the front of the Motor Platform.

Contact your local AVIX Autonomic dealer for any questions related to product safety.

3. Assembly

- 1 Carefully take all parts out of the AVIX Autonomic flight case.
- 2 Position the Motor Platform on a flat and horizontal surface.
- 3 Place the Payload on top of the Motor Platform by aligning the four holes on the top of the Motor Platform with the holes on the sides of the Payload. Make sure to position the Payload in the correct orientation, as shown in the Assembly overview on page 2.

⚠ CAUTION: Although the Payload may rest on the Motor Platform, it is not yet connected. Perform the next step carefully so the Payload will not drop.

- 4 Use the 4 (four) screws to secure the Payload to the Motor Platform. Use the Hex Key to tighten the screws.
- 5 Unscrew the connector protection cap on the back of the Rear Cap.
- 6 Connect the Payload plug exiting on the side of the Motor Platform to the connector on the back of the Rear Cap. Make sure to tighten the screw connection properly to establish a watertight connection.

- 7 Connect the plug exiting the base of the Motor Platform to the Power Switch Module. Make sure to tighten the screw connection properly to establish a watertight connection.
- 8 Connect the plug exiting the Mains Power Adapter to the remaining connector on the Power Switch Module. Make sure to tighten the screw connection properly to establish a watertight connection.
- 9 Secure the base of the Motor Platform to its supporting structure.

3.1 Preparing the mains power connection

⚠ WARNING: Always make sure that all equipment is de-energized and disconnected from mains power before working on the mains power connection.

- 1 Connect the CEE Connector (mains power side) to the power cable (cable specifications are shown below). Use a flat blade screwdriver to open the connector and expose its terminals. Use a Philips screw driver to secure the cores to the terminals. Make sure the cores are stripped sufficiently and the screws are secured tightly to ensure proper conductivity. Close the connector again by combining its parts until it clicks into place.
- 2 Power can be restored. Provide a voltage of 100 - 277V to the power cable. The mains power connection is ready for use.

i The power cable is not provided with the AVIX Autonomic.

Cable requirements:

- Outdoor rated
- Conductor: 1 - 2.5 mm² (14 - 17 AWG)
- Cores: 3
- Outer diameter: 6-15 mm (0.25 – 0.6")

3.2 Connecting the Autonomic to power

- 1 Connect the CEE Plug (exiting the Mains Power Adapter) to the CEE connector. The AVIX Autonomic is now powered and ready to be configured.

4. Configuration

⚠ CAUTION:

- Do not drop. This product may malfunction if subjected to strong shocks or vibration.
- The AVIX Autonomic is an automated laser device intended for bird repelling purposes only.
- When using the AVIX Autonomic, always adhere to the safety precautions outlined in this document.
- To prevent injuries or damage as a result of entrapment, stay clear of the Motor Platform during operation.

4.1 Power up

⚠ CAUTION: Before using the AVIX Autonomic ensure that:

- All bolts connecting the base of the Motor Platform to the supporting structure are tightly secured.
- The AVIX Autonomic is not allowed to wobble or tilt when operational. If stability is insufficient, improve supporting structure.
- The AVIX Autonomic should not be subjected to surface vibrations, as these can lead to a displacement of the laser projection over time.
- All power cables are properly connected.
- The emergency stop button is deactivated.
- The key is positioned inside the key lock switch and is switched to the 'active' position (turn in a clockwise direction).

⚠ WARNING: Do not stare into the laser beam during configuration.

⚠ CAUTION After pressing the (⏻) button, the Motor Platform may start moving. Use the (⏻) button to switch the AVIX Autonomic ON/OFF. When powered, the AVIX Autonomic is automatically switched ON.

4.2 Connecting to the device

Before establishing a connection, make sure:

- You have a mobile device with Bluetooth functionality.

i An Android device with Android version 6.0 (or higher) and Bluetooth version 4.0 (or higher) is recommended, other devices might experience problems during configuration.

- Google Chrome is installed on your device.
- You have an active internet connection.
- Bluetooth and location are enabled on your mobile device.

Step 1 Open Google Chrome.

Step 2 Navigate to <http://connect.AVIX.com>.

Step 3 Login with your AVIX Connect account.

Step 4 Select 'Autonomic configuration'.

Step 5 The following window will appear. Press ().

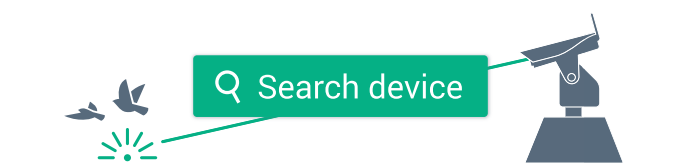

Step 6

A list of AVIX Autonomic devices within Bluetooth range will appear. Select the desired Autonomic and press (**Pair**). If no devices are shown in the list, move closer to the Autonomic and try again.

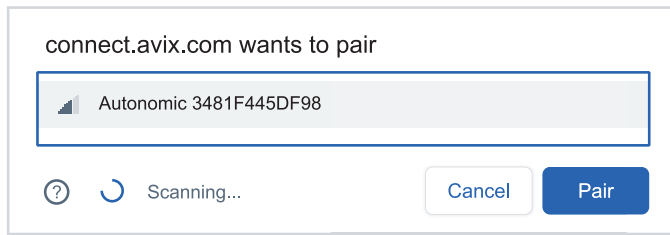

The following window will appear:

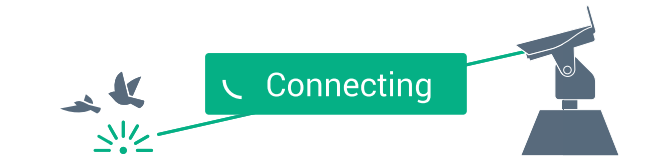

The connection will be established with the Autonomic (this could take a moment). If no connection is established after 1 minute, please refresh the page and try again.

Step 7

After the connection is established, the dashboard screen as shown in figure 2.1 on page 3 will appear.

4.3 Configuring the device

To start configuration, add at least one timeslot by pressing the (**+ ADD TIMESLOT**) button.

Step 8

After creating at least one timeslot, create a pattern by pressing the (**+ ADD PATTERN**) button. The screen as shown in figure 2.2 on page 3 will appear.

Step 9

After pressing the (**+ ADD PATTERN**) button the pattern configuration screen as shown in figure 2.3 on page 3 will appear.

- 9.1 The pattern is active by default, to deactivate the pattern without having to remove it, press the toggle button () Only active patterns will be executed.
- 9.2 Set a pattern name.
- 9.3 Set a value for cycles between 1 and 10. The amount represents the number of times the pattern is repeated before the next pattern is played (if more than one pattern is active within a timeslot). Example; if 'Pattern A' has been set to 1 cycle and 'Pattern B' is set to 3 cycles, and they both are active within the same timeslot, 'Pattern B' will be played 3 times for each time 'Pattern A' is played within that timeslot.
- 9.4 Set the speed between 1-100%.

9.5 Set the laser brightness between 1-100%.

9.6 Select at least one timeslot during which this pattern will be played.

9.7 Finally, press (**SET**) to set up waypoints.

Step 10

The waypoint screen as shown in figure 2.4 will appear:

- 10.1 To start creating waypoints, first press and drag the joystick () in the center of the window to any direction to start moving the Motor Platform. For accurate movement, the four fine-tune buttons () on the side of the joystick area can be used. When, in the top of the screen, (**ARROW STEP SIZE**) is pressed, the sensitivity of the fine-tune buttons can be adjusted.

Direct the laser towards an area in which it is safe to switch ON the laser.

⚠ WARNING: In the next step, the laser will be switched on. Do not stare into the laser beam.

- 10.2 Switch ON the laser by pressing the toggle button () to the right top of the joystick area. After enabling the laser, the laser brightness can be adjusted at the top of the window and the joystick button turns green ().

⚠ *The laser brightness setting in this window only affects the brightness during setup, and has no effect on the laser brightness when the device plays the pattern during normal autonomous operation (this brightness setting has been defined in Step 9)*

- 10.3 Move the laser to the desired position of the first waypoint and press the () button. Move the laser to the next position and press the () button again. Continue this process until the desired pattern is created.

⚠ *After saving the first waypoint in a pattern, the laser can only move either horizontally or vertically between two waypoints. Each time a change of direction is required, a waypoint needs to be saved first.*

- 10.4 To remove a waypoint, select it in the waypoint list on the bottom of the window. Then press the () button. When a new waypoint is saved, it is always added at the end of the list, regardless of what waypoint is selected at the time.
- 10.5 The laser power button (), which is positioned below the joystick button (), can be used to deactivate the laser between 2 subsequent waypoints. To deactivate the trajectory between two waypoints, select the first of the two waypoints and press the laser power button. The waypoint will turn from green to white in the waypoint list.



For example; when waypoint 3 is deactivated, the laser will be switched off between waypoints 3 and 4. After waypoint 4, the laser will switch on again.

10.6 After completing the pattern, press the () in the top right corner of the window.

Step 11

You will return to the dashboard as shown in figure 2.5 on page 3. After completing pattern(s) and timeslot(s), press the () button at the top of the dashboard screen to activate the AVIX Autonomic for automated bird repelling. The LED on the back of the Autonomic turns from yellow to blue.

5. Maintenance

 **CAUTION:** Always switch OFF the AVIX Autonomic before performing maintenance.

Perform the following maintenance steps at least once a week:

- Ensure the AVIX Autonomic cannot wobble or tilt on its position. If stability has been diminished, add more ballast to the frame or secure the system more firmly to the subsurface.
- Ensure the AVIX Autonomic executes its patterns in the intended areas.

Perform the following maintenance steps at least once a month:

- Clean the lens with a wet cloth. A dirty lens may cause undesired reflections and reduced effectiveness.
- Determine whether the movement of the system is hampered in any way. Remove any foreign matter between the moving parts of the Motor Platform. Disconnect the AVIX Autonomic from power before performing this step.
- Check if the time settings are still correct. Note that the AVIX Autonomic won't automatically adjust to daylight saving time.

Storage

The AVIX Autonomic is designed to withstand outdoor environments. If the AVIX Autonomic will not be used for an extended period of time, store it, in a dry, well-ventilated environment.

 **CAUTION:** Do not store your AVIX Autonomic in a location that is:

- Poorly ventilated or subject to humidity of over 60%.
- Exposed to temperatures above 65°C (149°F) or below -20°C (-4°F).

The AVIX Autonomic can be cleaned with a wet cloth. Do NOT use a high-pressure pump for cleaning as this may damage the product.

Disposal



Do not dispose of the AVIX Autonomic with household material. Recycle in accordance with the regulations applicable to your location.



Always recycle batteries.

6. Warranty



CAUTION: Any attempt to disassemble the product beyond disconnecting modules voids the product warranty.

The AVIX Autonomic is developed and produced according to the highest quality standards. Should you encounter any problems with your product, please read this manual carefully. If your AVIX Autonomic shows a defect, or if you need assistance, please contact your local dealer. Should any defect arise as a result of production faults, free repair or replacement is guaranteed. The AVIX Autonomic has a warranty period of 12 months, starting on the date of purchase. In case of replacement, the warranty period of the original product will remain valid.

Warranty conditions

The warranty is valid if the AVIX Autonomic is used in accordance with the instructions in this manual and for the purpose for which it was designed. The warranty is valid when a valid receipt is presented that shows the date of purchase, the name of the dealer and the product name.

The warranty is invalid when:

- Damage due to falling or jolting occurs.
- The serial number has been removed.
- Attempts to disassemble the product have been made. Disconnecting a module is not considered disassembly.
- Any repairs or attempts at repairs have been carried out by unauthorized persons.
- Any defects have occurred as a result of using equipment other than provided by Bird Control Group (including, but not limited to, using a different power adapter).
- Any defects have occurred as a result of misuse or use in environments that are not prescribed.
- The defect is a result of normal wear of replaceable parts (including, but not limited to, the battery).

7. Spare parts

The following AVIX Autonomic spare parts are available:

- AVIX Autonomic Payload (housing including laser and PCB)
- AVIX Autonomic Housing (enclosure only)
- AVIX Autonomic Rear Cap
- AVIX Autonomic Light Module
- AVIX Autonomic Motor Platform
- AVIX Autonomic Power Switch Module
- AVIX Autonomic Mains Power Adapter

8. Accessories

The following AVIX Autonomic accessories are available.

Mounting system

- Vertical Mounting Bracket
- Horizontal Mounting Frame
- Adjustable Frame Extender
- Power Extension Cable (5m)

Solar charging system

- Battery Box Kit (24V)
- Battery
- Solar Panel

- Solar Panel Pole Brackets
- Solar Panel Frame Brackets
- Solar Panel Extension Cable (5m)

Remote access

- AVIX Remote Status & Control Module
- Remote Control (RF) Starter Kit
- Remote Control (RF) Receiver Kit









Extra accessories

- Laser Warning Sign
- Laser Safety Glasses

9. Troubleshooting

If the AVIX Autonomic is not performing as expected, check the bird-shaped LED indicator on the back of the AVIX Autonomic enclosure to identify the device status (see status list below). Alternatively, check the device status in the user interface (see chapter 4; Configuration).

The Autonomic has encountered an error and user action is required. If the autonomic was bursting it will automatically try to resolve this error every minute. To check the error type, please connect to the AVIX Autonomic and check the device status in the user interface (see chapter 4.2; Connecting to the device).

LED color	LED appearance	Status
	OFF Static	OFF (no power): No power to AVIX Autonomic.
	Blinking white	OFF (powered): Press I/O button to switch ON/OFF the Autonomic.
	Static purple	Initialization: AVIX Autonomic is starting up. If this takes more than 20 seconds, disconnect power and try again.
	Static yellow	Standby: The Autonomic is switched on, but either no patterns or timeslots are defined or bursting is disabled.
	Static green	Bursting (active): The Autonomic is running a pattern (caution: laser output).
	Static blue	Bursting (pause): The AVIX Autonomic is waiting to perform its next pattern.
	Blinking blue	Bursting (outside timeslot): The AVIX Autonomic is waiting to return to its predefined timeslot(s). No patterns will be played.
	Blinking red	Error: The AVIX Autonomic has encountered an error and user action is required. If the autonomic was bursting it will automatically try to resolve this error every minute. To check the error type, please connect to the AVIX Autonomic and check the device status in the user interface (see chapter 3).
	Static red	Emergency: The AVIX Autonomic has stopped working because of the emergency stop on the Power Switch Module has been pressed. After the emergency stop has been released, the color of the AVIX Autonomic remains red.



European Office

Molengraaffsingel 12

2629 JD Delft

The Netherlands

T + 31 23 230 2030

E hello@birdcontrolgroup.com

W www.birdcontrolgroup.com

W www.avix.com

North American Office

27350 SW 95th Ave. Suite 3022

Wilsonville, OR 97070

United States

T +1-844-406-9280 (toll-free)

CONFIDENTIAL

AVIX Autonomic is designed and manufactured by **Bird Control Group** 

Published: 05-07-2019 - V1.0