

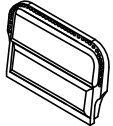









ASSEMBLY INSTRUCTIONS / INSTRUCTIONS D'ASSEMBLAGE

ITEM NO: 194S9268BRW-1

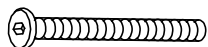
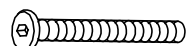
Chair – Fauteuil

NO.	PARTS LIST	QTY	DESCRIPTION
A		1	BACK REST DOSSIER
B		1	EAR LSF/ OREILLE -GAUCHE
C		1	EAR RSF/ OREILLE - DROITE
D		1	SEAT/ SIÈGE
E	 60*55*68mm	2	BACK WOODEN LEGS PIEDS ARRIÈRE EN ROIS
F	 ø110*105mm	2	FRONT WOODEN LEGS PIED AVANT

NO.	HARDWARE LIST	QTY	DESCRIPTION
G	 M8*75MM	2	BOLT/ BOULON
H	 M8*60MM	2	BOLT/ BOULON
I	 M8	2	FLAT WASHER RONDELLE PLATE
J	 M8	2	SPRING WASHER RONDELLE D'ARRÊT
K	 M5*100*38MM	1	ALLEN KEY CLÈ ALLEN

CAUTION: PLEASE READ ALL INSTRUCTIONS CAREFULLY BEFORE STARTING ASSEMBLY PROCESS. IT IS RECOMMENDED TO USE TWO PEOPLE WHEN ASSEMBLING AND REMOVING THE INSIDE BACKS TO AND FROM THE BASE OF THE FUNITURE.

ATTENTION: VEUILLEZ LIRE ATTENTIVEMENT TOUTES LES INSTRUCTIONS AVANT DE COMMENCER L'ASSEMBLAGE PROCESSUS. IL EST RECOMMANDÉ D'UTILISER DEUX PERSONNES LORS DU MONTAGE ET DU DÉMONTAGE L'INTÉRIEUR DOS VERS ET DEPUIS LA BASE DU MOBILIER

STEP 1: Side LSF & RSF ears up to lock

ÉTAPE 1: Oreilles latérales lsf et rsf vers le haut pour verrouiller

STEP 2: Plug back into the seat base slot and lock tight with bolts and screw driver

ÉTAPE 2: Rebranchez-le dans la fente de la base du siège et verrouillez-le avec des boulons et un tournevis

STEP 3: Setup front and back legs

ÉTAPE 3: Configurez les pattes avant et arrière

ASSEMBLY INSTRUCTIONS / INSTRUCTIONS D'ASSEMBLAGE

ITEM NO: 194S9268BRW-1

Chair – Fauteuil

Step 1/ Étape 1

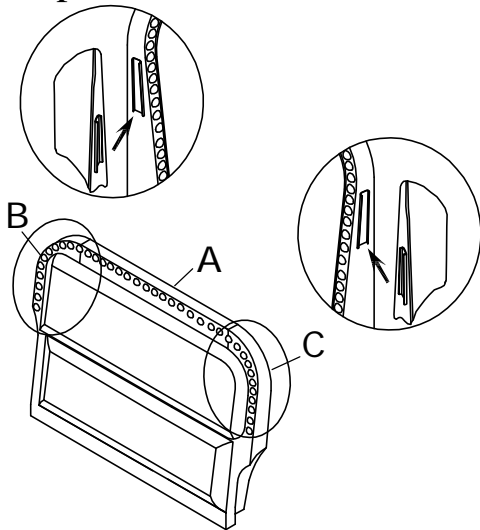

Step 2/ Étape 2

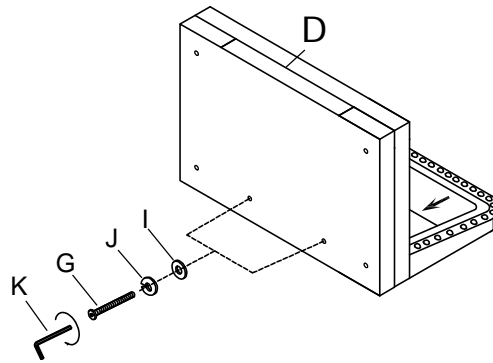

Step 3/ Étape 3

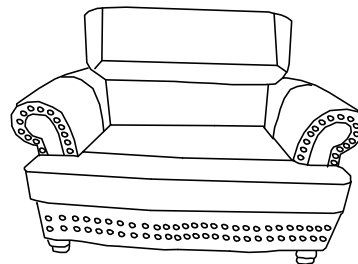
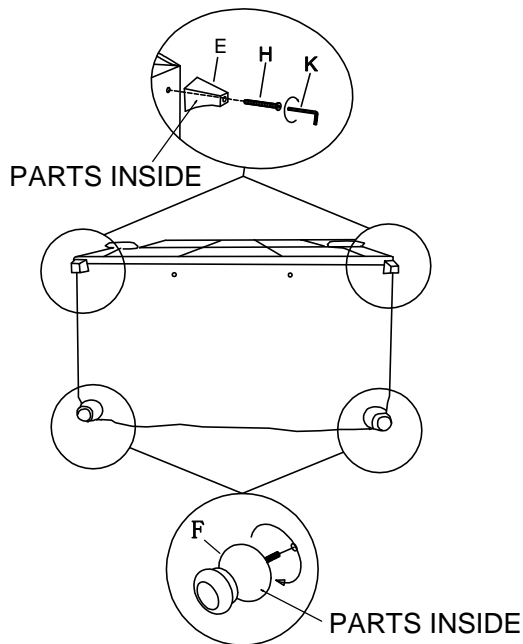

CARE INSTRUCTION FOR LEATHER GEL FURNITURE

.In order to maintain the original appearance of your fabric furniture, please follow below care procedures:

- .Avoid exposing furniture directly to sunlight or heating and air condition outlets. Sunlight and / or exposure to heating and air conditioning outlets will fade/ damage fabric. Do not place your upholstered furniture too close to windows, radiators, vents and be sure to use window treatments to block the sun's rays.
- .Wipe with a soft brush to remove dust.

INSTRUCTIONS DE SOINS POUR LES MUEBLES EN TISSU





.Pour conserver l'aspect original de vos meubles en tissu, veuillez procéder comme suit:



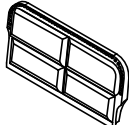

- .Éviter d'exposer les meubles aux rayons directs du soleil ou aux sorties de chaleur et d'air climatisé.
- .Pour enlever la poussière, essayer avec une brosse douce.

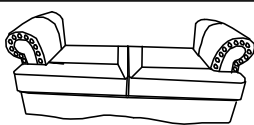
ASSEMBLY INSTRUCTIONS / INSTRUCTIONS D'ASSEMBLAGE

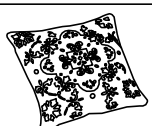
ITEM NO: 194S9268BRW-2

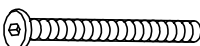
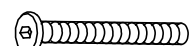
LOVESEAT / CAUSEUSE

NO.	PARTS LIST	QTY	DESCRIPTION
A		1	BACK REST DOSSIER
B		1	EAR LSF/ OREILLE -GAUCHE
C		1	EAR RSF/ OREILLE - DROITE
D		1	SEAT/ SIÈGE
E	 60*55*68mm	2	BACK WOODEN LEGS PIEDS ARRIÈRE EN ROIS
F	 ø110*105mm	2	FRONT WOODEN LEGS PIED AVANT
G		2	PILLOW/ OREILLER

NO.	HARDWARE LIST	QTY	DESCRIPTION
G	 M8*75MM	3	BOLT/ BOULON
H	 M8*60MM	2	BOLT/ BOULON
I	 M8	3	FLAT WASHER RONDELLE PLATE
J	 M8	3	SPRING WASHER RONDELLE D'ARRÊT
K	 M5*100*38MM	1	ALLEN KEY CLÈ ALLEN

CAUTION: PLEASE READ ALL INSTRUCTIONS CAREFULLY BEFORE STARTING ASSEMBLY PROCESS. IT IS RECOMMENDED TO USE TWO PEOPLE WHEN ASSEMBLING AND REMOVING THE INSIDE BACKS TO AND FROM THE BASE OF THE FUNITURE.

ATTENTION: VEUILLEZ LIRE ATTENTIVEMENT TOUTES LES INSTRUCTIONS AVANT DE COMMENCER L'ASSEMBLAGE PROCESSUS. IL EST RECOMMANDÉ D'UTILISER DEUX PERSONNES LORS DU MONTAGE ET DU DÉMONTAGE L'INTÉRIEUR DOS VERS ET DEPUIS LA BASE DU MOBILIER

STEP 1: Side LSF & RSF ears up to lock

ÉTAPE 1: Oreilles latérales lsf et rsf vers le haut pour verrouiller

STEP 2: Plug back into the seat base slot and lock tight with bolts and screw driver

ÉTAPE 2: Rebranchez-le dans la fente de la base du siège et verrouillez-le avec des boulons et un tournevis

STEP 3: Setup front and back legs

ÉTAPE 3: Configurez les pattes avant et arrière

ASSEMBLY INSTRUCTIONS / INSTRUCTIONS D'ASSEMBLAGE

ITEM NO: 194S9268BRW-2
LOVESEAT / CAUSEUSE

Step 1/ Étape 1

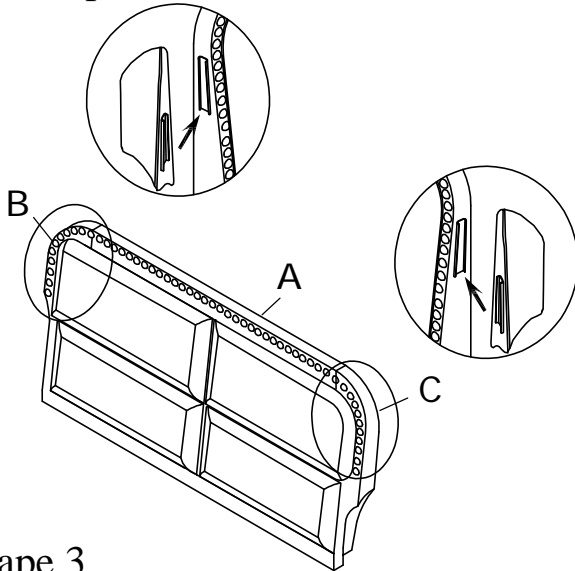

Step 2/ Étape 2

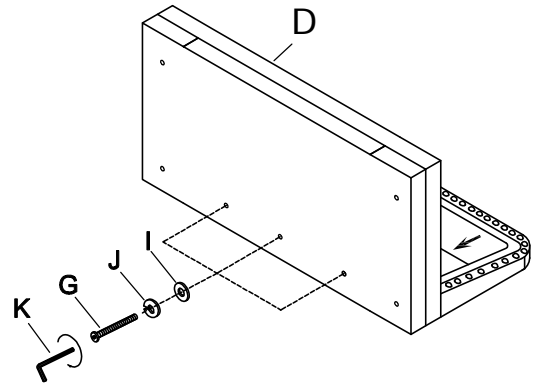

Step 3/ Étape 3

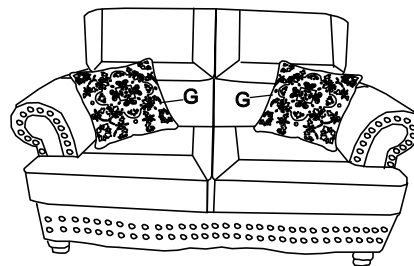
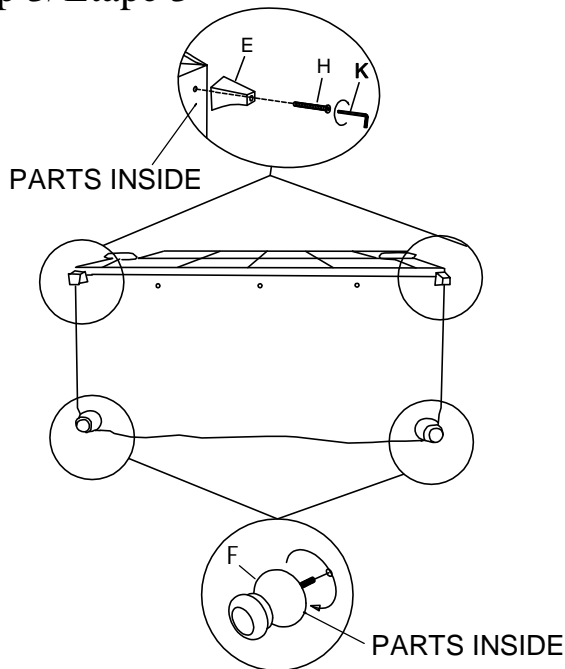

CARE INSTRUCTION FOR LEATHER GEL FURNITURE

.In order to maintain the original appearance of your fabric furniture, please follow below care procedures:
.Avoid exposing furniture directly to sunlight or heating and air condition outlets. Sunlight and / or exposure to heating and air conditioning outlets will fade/ damage fabric. Do not place your upholstered furniture too close to windows, radiators, vents and be sure to use window treatments to block the sun's rays.
.Wipe with a soft brush to remove dust.









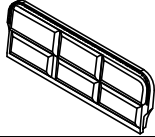
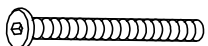

INSTRUCTIONS DE SOINS POUR LES MUEBLES EN TISSU
.Pour conserver l'aspect original de vos meubles en tissu, veuillez procéder comme suit:

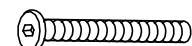
.Éviter d'exposer les meubles aux rayons directs du soleil ou aux sorties de chaleur et d'air climatisé.
.Pour enlever la poussière, essayer avec une brosse douce.

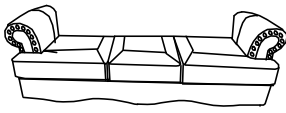
ASSEMBLY INSTRUCTIONS / INSTRUCTIONS D'ASSEMBLAGE

ITEM NO: 194S9268BRW-3

SOFA/ SOFA

NO.	PARTS LIST	QTY	DESCRIPTION	NO.	HARDWARE LIST	QTY	DESCRIPTION
A		1	BACK REST DOSSIER	G	 M8*75MM	4	BOLT/ BOULON
B		1	EAR LSF/ OREILLE -GAUCHE	H	 M8*60MM	2	BOLT/ BOULON
C		1	EAR RSF/ OREILLE - DROITE	I	 M8	4	FLAT WASHER RONDELLE PLATE
D		1	SEAT/ SIÈGE	J	 M8	4	SPRING WASHER RONDELLE D'ARRÊT
E	 60*55*68mm	2	BACK WOODEN LEGS PIEDS ARRIÈRE EN ROIS	K	 M5*100*38MM	1	ALLEN KEY CLÈ ALLEN
F	 ø110*105mm	2	FRONT WOODEN LEGS PIED AVANT				
G		2	PILLOW/ OREILLER				

CAUTION: PLEASE READ ALL INSTRUCTIONS CAREFULLY BEFORE STARTING ASSEMBLY PROCESS. IT IS RECOMMENDED TO USE TWO PEOPLE WHEN ASSEMBLING AND REMOVING THE INSIDE BACKS TO AND FROM THE BASE OF THE FUNITURE.

ATTENTION: VEUILLEZ LIRE ATTENTIVEMENT TOUTES LES INSTRUCTIONS AVANT DE COMMENCER L'ASSEMBLAGE PROCESSUS. IL EST RECOMMANDÉ D'UTILISER DEUX PERSONNES LORS DU MONTAGE ET DU DÉMONTAGE L'INTÉRIEUR DOS VERS ET DEPUIS LA BASE DU MOBILIER

STEP 1: Side LSF & RSF ears up to lock

ÉTAPE 1: Oreilles latérales lsf et rsf vers le haut pour verrouiller

STEP 2: Plug back into the seat base slot and lock tight with bolts and screw driver

ÉTAPE 2: Rebranchez-le dans la fente de la base du siège et verrouillez-le avec des boulons et un tournevis

STEP 3: Setup front and back legs

ÉTAPE 3: Configurez les pattes avant et arrière

ASSEMBLY INSTRUCTIONS / INSTRUCTIONS D'ASSEMBLAGE
ITEM NO: 194S9268BRW-3
SOFA/ SOFA

Step 1/ Étape 1

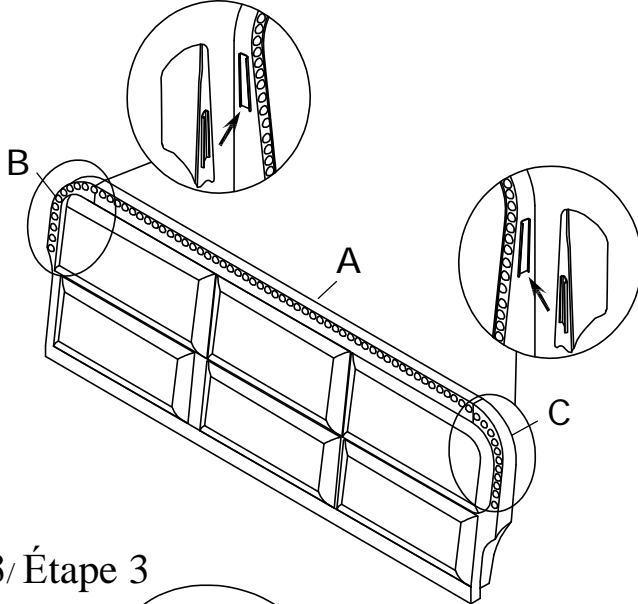

Step 2/ Étape 2

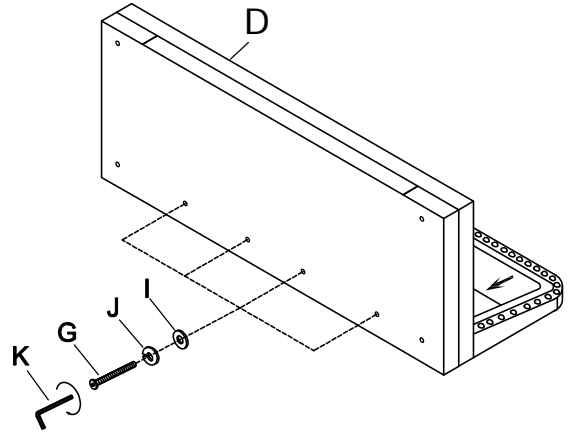

Step 3/ Étape 3

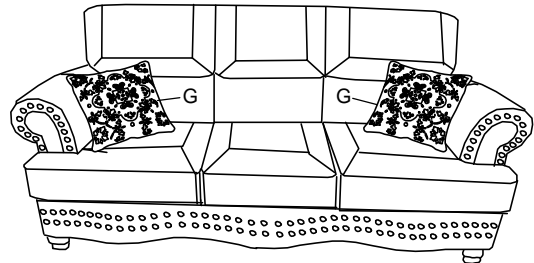
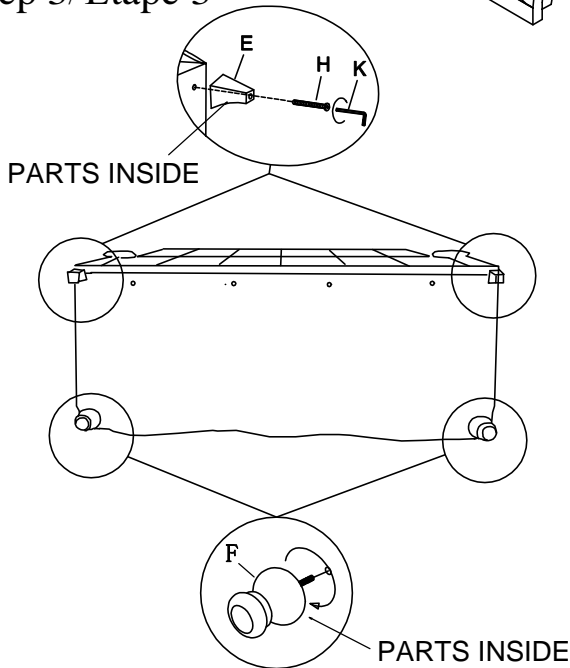

CARE INSTRUCTION FOR LEATHER GEL FURNITURE
 .In order to maintain the original appearance of your fabric furniture, please follow below care procedures:
 .Avoid exposing furniture directly to sunlight or heating and air condition outlets. Sunlight and / or exposure to heating and air conditioning outlets will fade/ damage fabric. Do not place your upholstered furniture too close to windows, radiators, vents and be sure to use window treatments to block the sun's rays.
 .Wipe with a soft brush to remove dust.

INSTRUCTIONS DE SOINS POUR LES MUEBLES EN TISSU
 .Pour conserver l'aspect original de vos meubles en tissu, veuillez procéder comme suit:
 .Éviter d'exposer les meubles aux rayons directs du soleil ou aux sorties de chaleur et d'air climatisé.
 .Pour enlever la poussière, essayer avec une brosse douce.