

**ASSEMBLY INSTRUCTION
INSTRUCTION D' ASSEMBLAGE**

ROUND DINING TABLE / TABLE DESALLE À MANGER

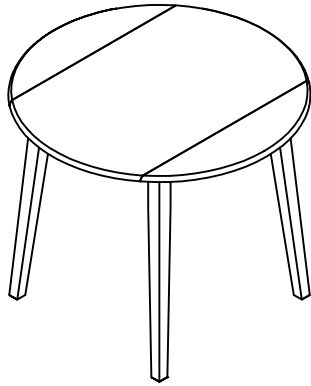

Thank you for purchasing this product. Please take time to read and follow instructions below. Check that you have all parts and hardware before assembly. Parts apparently missing are often found in packing materials. If you do not have all parts listed, call us and they be sent to you immediately



Merci d'avoir acheté ce produit. Veuillez lire et suivre les instructions ci-dessous. Vérifiez avant le montage que vous avez toutes les pièces et fixations. Les pièces qui semblent manquer se trouvent souvent dans les matériaux d'emballage. Si vous n'avez pas toutes les pièces de la liste, demandez à votre détaillant et nous vous les enverrons immédiatement.







It is recommended to install protective pads under all legs and supports to avoid damage or scratches when placing furniture on a wood floor or other hard surface, and to limit indentation and prevent discoloration if placing on carpet.



Il est recommandé de placer des coussins protecteurs sous tous les pieds et toutes les bases des meubles pour éviter d'endommager ou d'égratigner les planchers en bois ou autres surfaces dures, et pour limiter l'empreinte et empêcher la décoloration quand les meubles reposent sur la moquette.

| PARTS LIST/LISTE DE PIÈCES | | | |
|----------------------------|---|------------------------------|------------|
| NO. | SKETCH / ESQUISSE | DESCRIPTION / LA DESCRIPTION | QTY / Q'TÉ |
| A |  | TABLE TOP / DESSUS DE TABLE | 1PC |
| B |  | LEG / PIED | 4PCS |

| HARDWARE LIST/LISTE DE QUINCAILLERIE | | | | |
|--------------------------------------|--------------------------------|-----------------|---|------------|
| NO. | DESCRIPTION / LA DESCRIPTION | SIZE / TAILLE | SKETCH / ESQUISSE | QTY / Q'TÉ |
| 1 | BOLT / BOULON | Ø5/16" x 2-3/8" |  | 8PCS |
| 2 | LOCK WASHER / RONDELLE D'ARRÊT | Ø5/16" |  | 8PCS |
| 3 | FLAT WASHER / RONDELLE PLATE | Ø5/16" x 1/16" |  | 8PCS |
| 4 | ALLEN KEY / CLÈ ALLEN | 1/6" x 2-1/4" |  | 1PC |

**ABOVE HARDWARE ARE PACKED IN 193D5890RD FOR ASSEMBLY.
LE MATÉRIEL CI-DESSUS EST EMBALLÉ DANS 193D5890RD POUR L'ASSEMBLAGE.

**Step 1/
Étape 1**

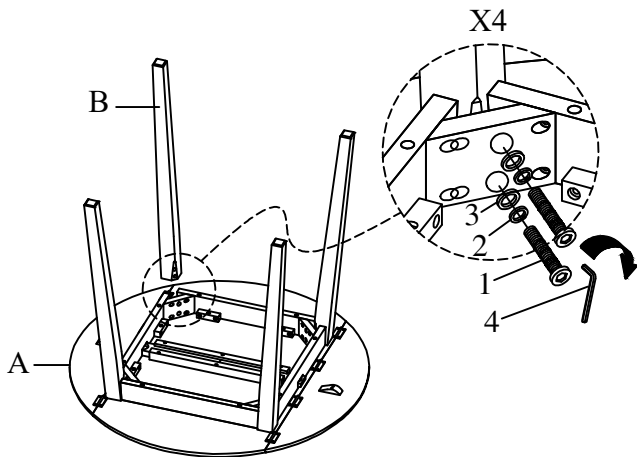

DO NOT TIGHTEN BOLTS UNTIL COMPLETELY ASSEMBLED.
NE PAS SERRER LES BOULONS JUSQU'À CE QUE LE MONTAGE SOIT COMPLÈTMENT TERMINÉ
MADE IN VIETNAM / FABRIQUÉ AU VIETNAM

**Step 2/
Étape 2**

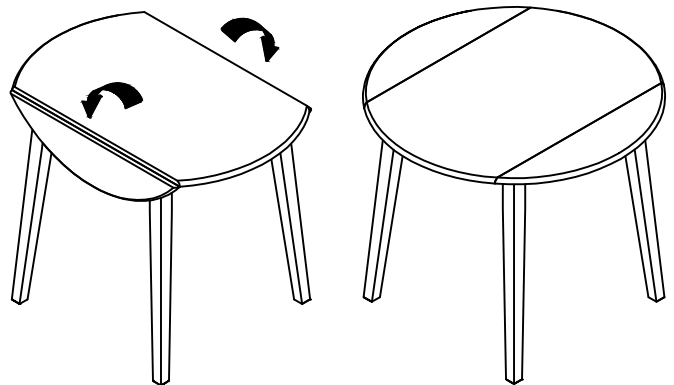

ASSEMBLY COMPLETED /
ASSEMBLAGE COMPLÉTÉ

ASSEMBLY INSTRUCTION INSTRUCTION D'ASSEMBLAGE SIDE CHAIR / CHAISE DROITE

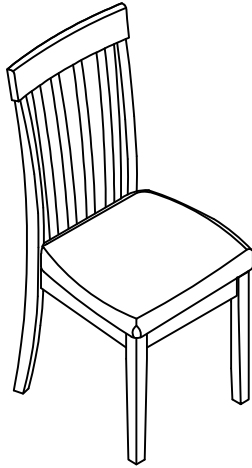

Thank you for purchasing this product. Please take time to read and follow instructions below. Check that you have all parts and hardware before assembly. Parts apparently missing are often found in packing materials. If you do not have all parts listed, call us and they be sent to you immediately.

Merci d'avoir acheté ce produit. Veuillez lire et suivre les instructions ci-dessous. Vérifiez avant le montage que vous avez toutes les pièces et fixations. Les pièces qui semblent manquer se trouvent souvent dans les matériaux d'emballage. Si vous n'avez pas toutes les pièces de la liste, demandez à votre détaillant et nous vous les enverrons immédiatement.





It is recommended to install protective pads under all legs and supports to avoid damage or scratches when placing furniture on a wood floor or other hard surface, and to limit indentation and prevent discoloration if placing on carpet.









Il est recommandé de placer des coussins protecteurs sous tous les pieds et toutes les bases des meubles pour éviter d'endommager ou d'égratigner les planchers en bois ou autres surfaces dures, et pour limiter l'empreinte et empêcher la décoloration quand les meubles reposent sur la moquette.

PARTS LIST/LISTE DE PIÈCES

| NO. | SKETCH / ESQUISSE | DESCRIPTION / LA DESCRIPTION | Q'TY / Q'TÉ |
|-----|---|---------------------------------|-------------|
| A |  | CHAIR BACK / DOSSIER DE CHAISE | 1PC |
| B |  | SEAT FRAME WITH CUSHION / SIÈGE | 1PC |
| C |  | LEG / PIED | 2PCS |

HARDWARE LIST/LISTE DE QUINCAILLERIE

| NO. | DESCRIPTION / LA DESCRIPTION | SIZE / TAILLE | SKETCH / ESQUISSE | Q'TY / Q'TÉ |
|-----|---------------------------------|----------------|---|-------------|
| 1 | BOLT / BOULON | Ø1/4" x 1-3/8" |  | 2PCS |
| 2 | BOLT / BOULON | Ø1/4" x 2-3/8" |  | 4PCS |
| 3 | BOLT / BOULON | Ø1/4" x 3" |  | 4PCS |
| 4 | LOCK WASHER / RONDELLE D'ARRÊT | Ø1/4" |  | 10PCS |
| 5 | FLAT WASHER / RONDELLE PLATE | Ø1/4" x 1/16" |  | 10PCS |
| 6 | ALLEN KEY / CLÈ ALLEN | 1/6" x 2-1/4" |  | 1PC |
| 7 | WOODEN DOWEL / CHEVILLE EN BOIS | Ø10 x 30mm |  | 1PC |

**ABOVE HARDWARE ARE PACKED IN 193D5890S FOR ASSEMBLY. LE MATÉRIEL CI-DESSUS EST EMBALLÉ DANS 193D5890S POUR L'ASSEMBLAGE.

Step 1/ Étape 1

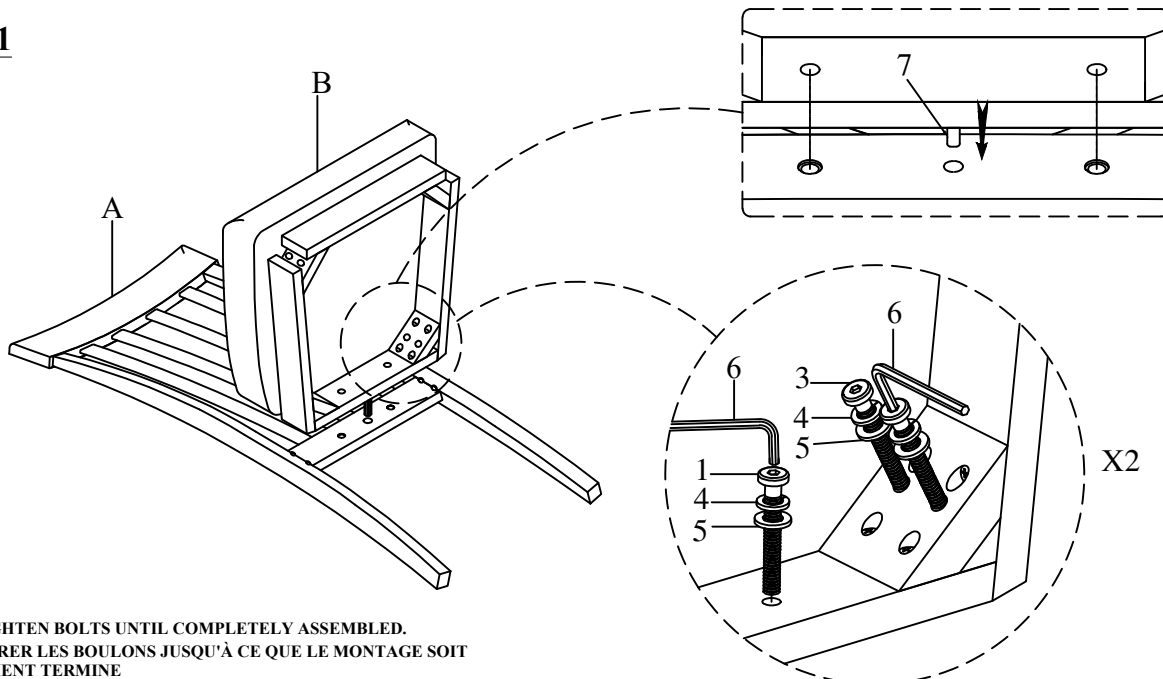

**DO NOT TIGHTEN BOLTS UNTIL COMPLETELY ASSEMBLED.
NE PAS SERRER LES BOULONS JUSQU'À CE QUE LE MONTAGE SOIT
COMPLÈTMENT TERMINÉ
MADE IN VIETNAM / FABRIQUÉ AU VIETNAM**

**ASSEMBLY INSTRUCTION
INSTRUCTION D'ASSEMBLAGE
SIDE CHAIR / CHAISE DROITE**

**Step 2/
Étape 2**

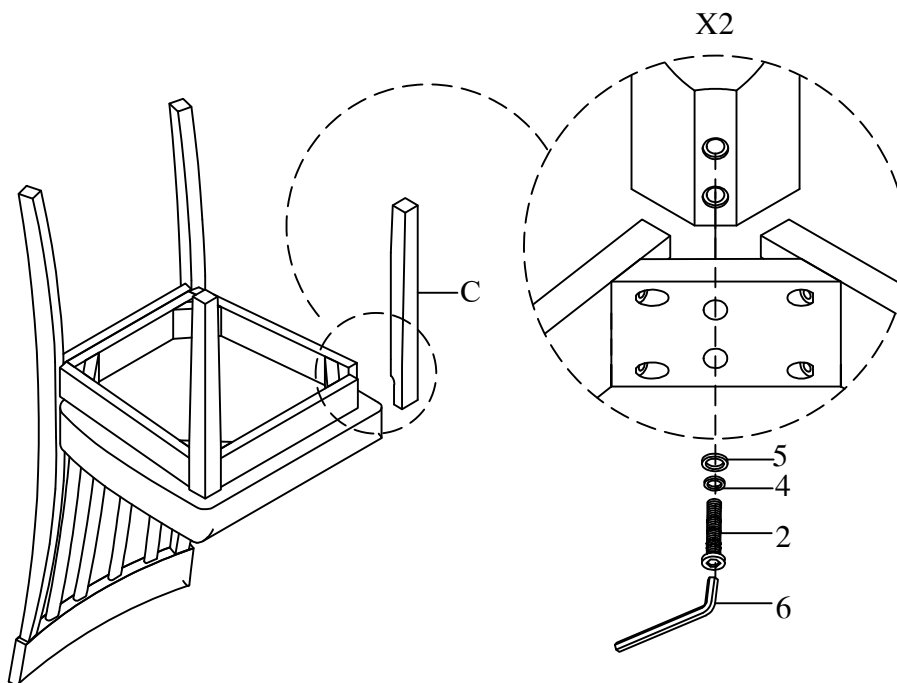

**Step 3/
Étape 3**

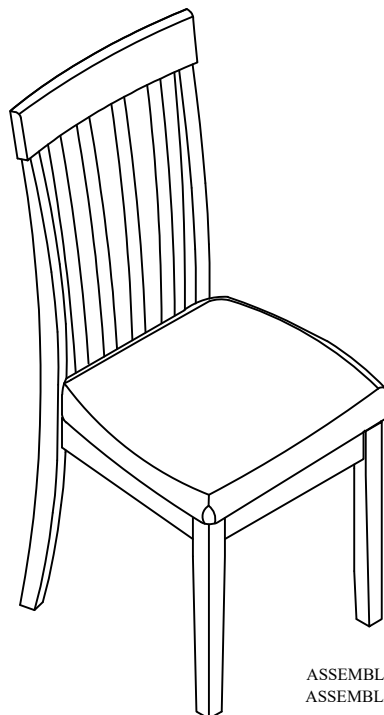

ASSEMBLY COMPLETED /
ASSEMBLAGE COMPLÉTÉ

DO NOT TIGHTEN BOLTS UNTIL COMPLETELY ASSEMBLED.
NE PAS SERRER LES BOULONS JUSQU'À CE QUE LE MONTAGE SOIT
COMPLÈTMENT TERMINÉ
MADE IN VIETNAM / FABRIQUÉ AU VIETNAM