

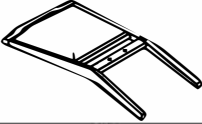





ASSEMBLY INSTRUCTION
ITEM NO: 193D5827S
DINING CHAIR

Thank you for purchasing this quality product. Be sure to check all packing material carefully for small parts that may have come loose inside the carton during shipment.

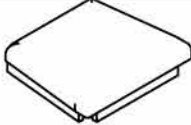
PARTS LISTS				HARDWARE LISTS				
NO.	Description	Sketch	Q'ty	NO.	Description	Sketch	Size	Q'ty
A	CHAIR BACK		1 PC	1	BOLT		1/4" - 20 x 3 "	4 PCS
				2	BOLT		1/4" - 20 x 2 1/2"	4 PCS
B	SEAT CUSHION WITH FRAME		1 PC	3	BOLT		1/4" - 20 x 1 3/4"	2 PCS
				4	SPRING WASHER		1/4" ID x 3/8" OD x 1/16" TK	10 PCS
C	LSF/ RSF FRONT LEGS		2 PCS	5	FLAT WASHER		1/4" ID x 6/8" OD x 1/16" TK	10 PCS
				6	ALLEN KEY		1/6"	1 PC

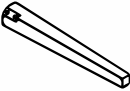
Step 1

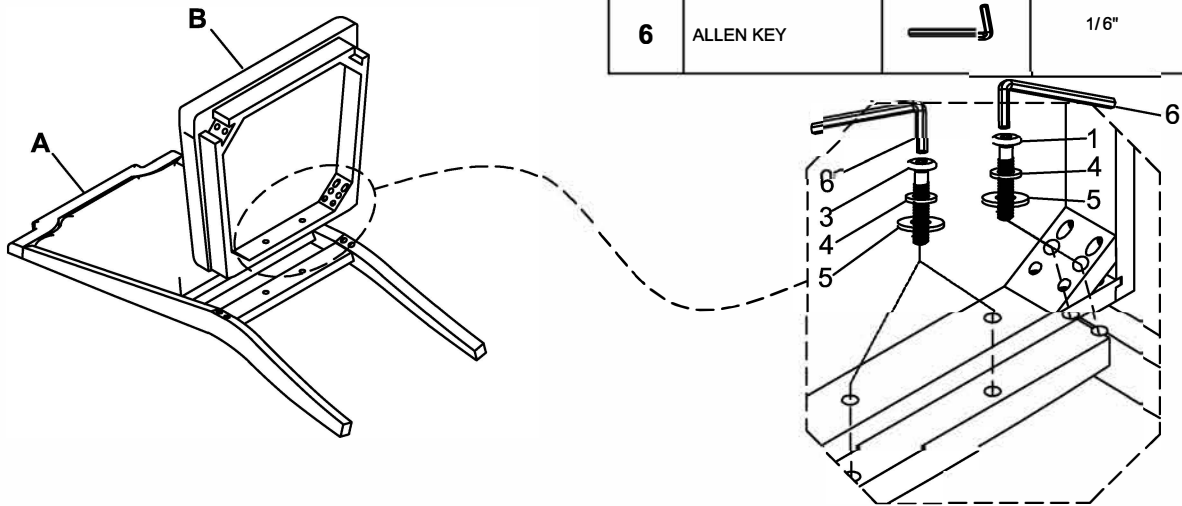

Step 2

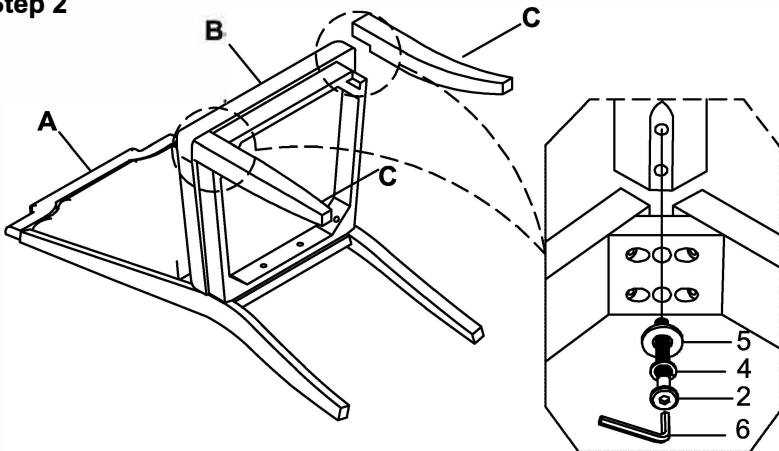

Step 3

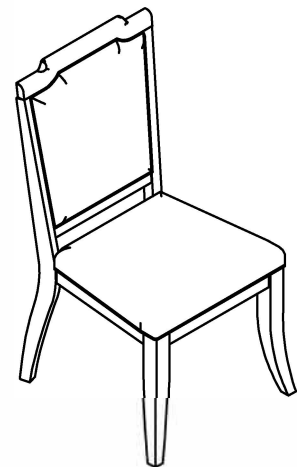

DO NOT TIGHTEN BOLTS UNTIL COMPLETELY ASSEMBLED.



It is recommended to install protective pads under all legs and supports to avoid damage or scratches when placing furniture on a wood floor or other hard surface, and to limit indentation and prevent discoloration if placing on carpet.