

ASSEMBLY INSTRUCTION

ITEM NO:191B1612F-1

FULL METAL BED

PART LIST:



A: LEGS FOR ALL
SIZE BED
2PCS

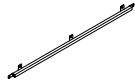

B: HEADBOARD CONNECTOR
BAR
2PCS

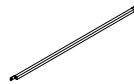

C: HEADBOARD
STRETCHER
1PCS

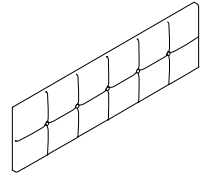

D: HEADBOARD
1PCS

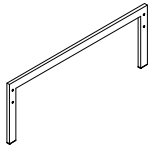

E: FOOTBOARD
1PC

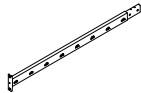

F: SIDE RAIL
2PCS

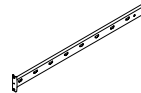

G: SIDE RAIL
2PCS

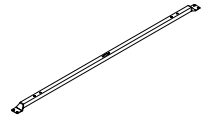

H: CENTER CROSS BAR
1PC



I: SUPPORT LEG
3PCS



J: SUPPORT LEG
2PCS

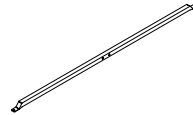

K: SIDE CROSS BAR
2PCS

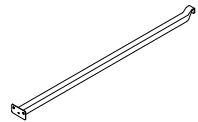

L: CENTER RAIL
SUPPORT BAR
2PCS

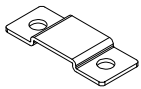

M: BRACKET
1PC

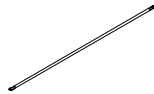

N: SLAT
14PCS



O: SLAT CONNECTOR
28PCS

HARDWARE SET:

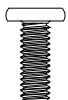

1: Bolt
1/4*17.5mm
X 20pcs



2: Bolt
1/4*22mm
X 12pcs

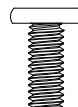

3: Bolt
5/16*19mm
X 8pcs



4: Bolt
1/4*40mm
X 6pcs



5: Nut
1/4
X 6psc



6: Washer
1/4
X 4psc



7: L-Allen Key
X 1pc



8: Wrench
X 1PC

Note: Please do not tighten all bolts until the bed is assembled completely.

STEP 1

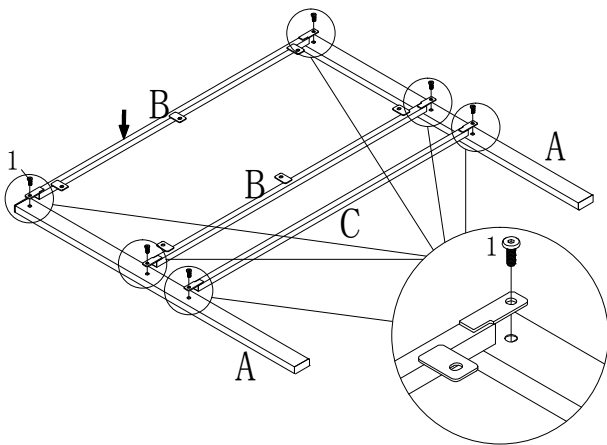

Hardware 1: 6 pcs

STEP 2

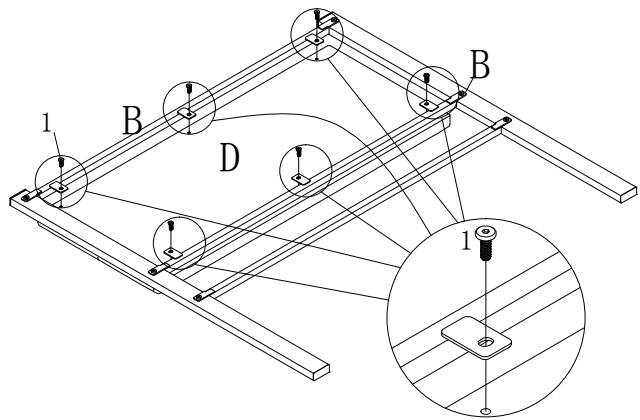

Hardware 1: 6 pcs

STEP 3

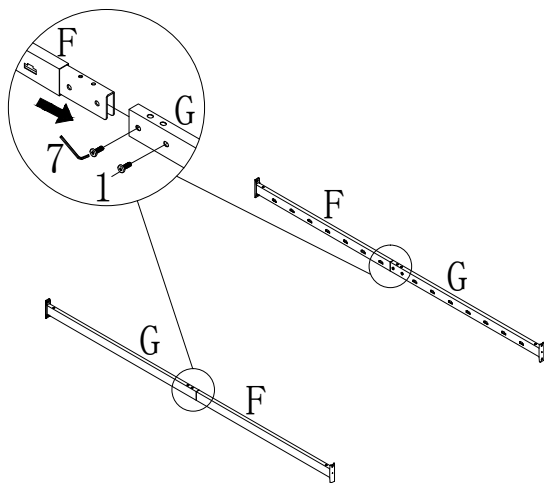

Hardware 1: 4 pcs

STEP 4

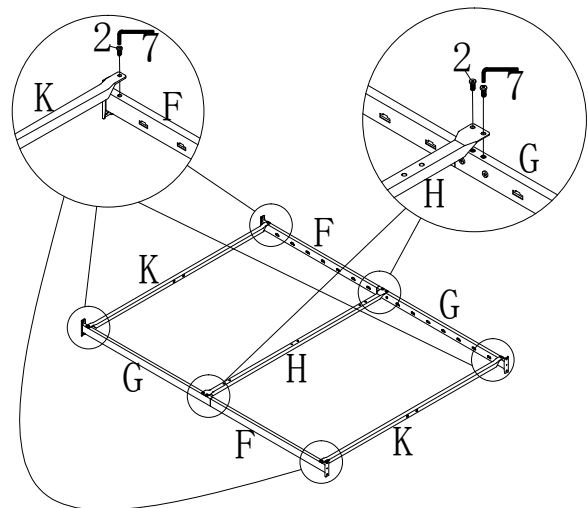

Hardware 2: 8 pcs

STEP 5

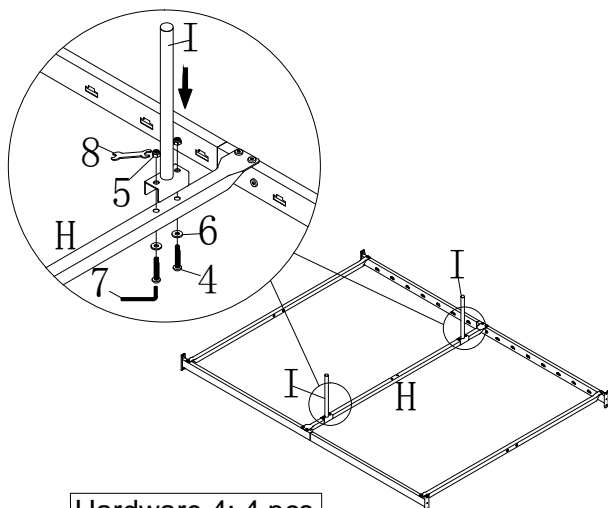

Hardware 4: 4 pcs
Hardware 5: 4 pcs
Hardware 6: 4 pcs

STEP 6

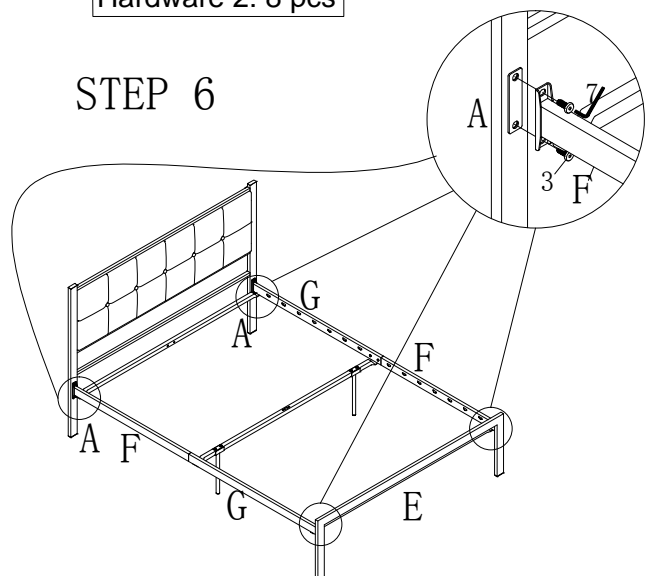

Hardware 3: 8 pcs

Note: Please do not tighten all bolts until the bed is assembled completely.

STEP 7

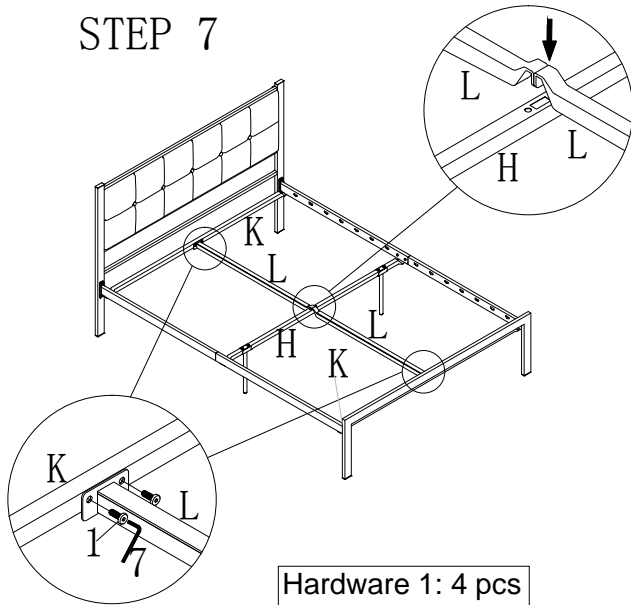

STEP 8

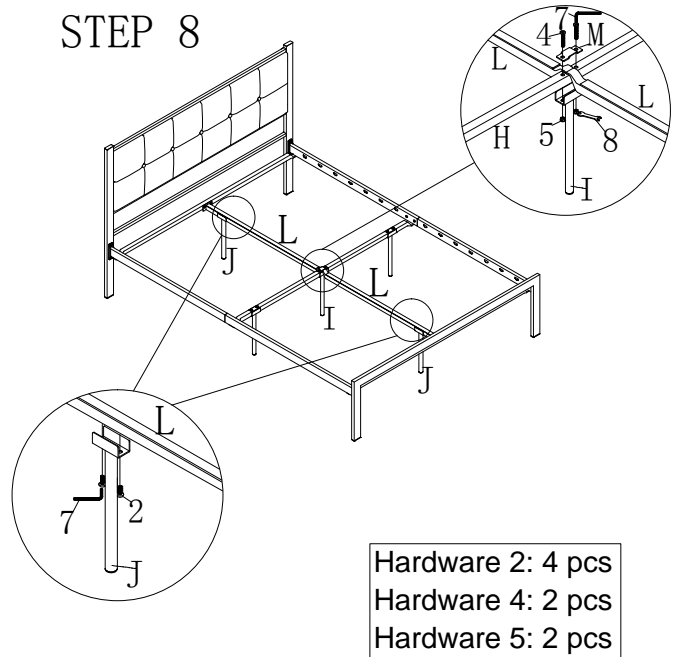

STEP 9

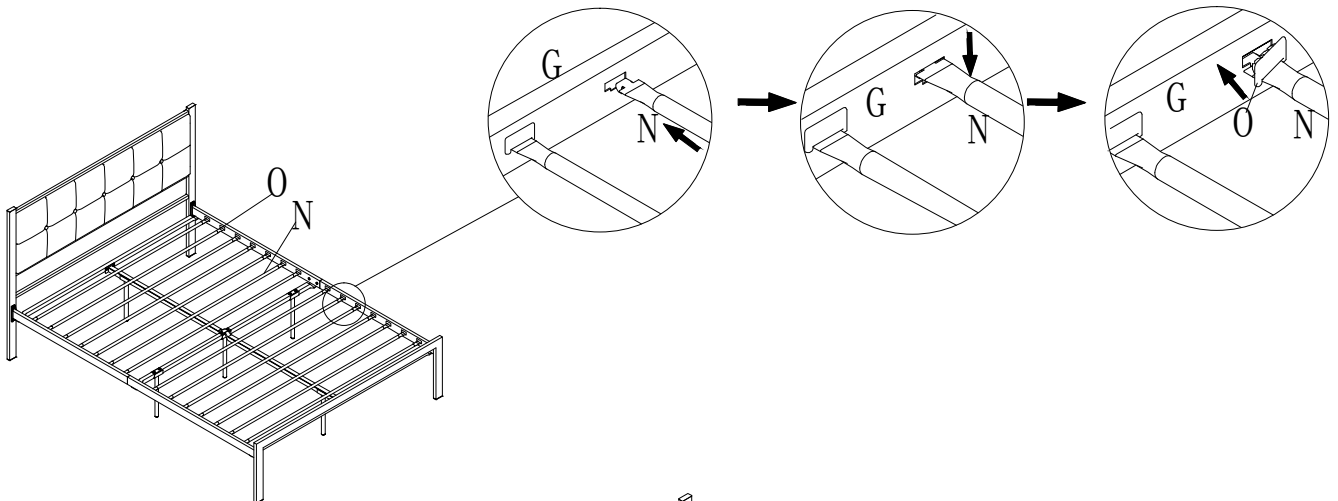

COMPLETED

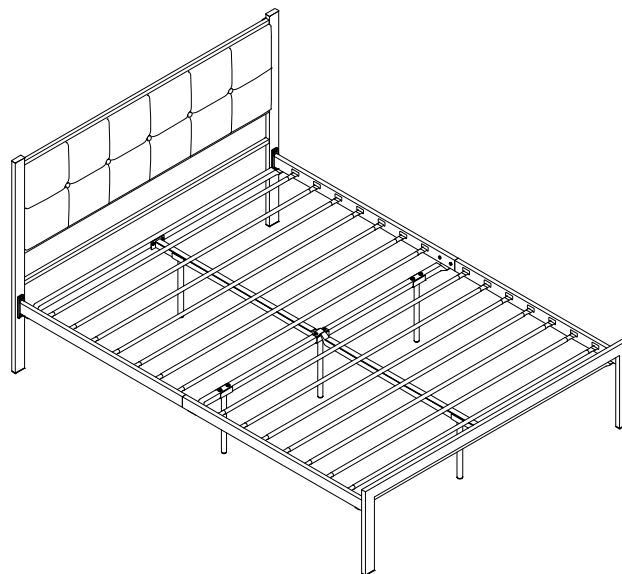

For items use on wooden floor, hard surfaces or carpets, it is recommended to install protective pads under all legs and supports to avoid/prevent from damages/scratches and discoloration.