

Item No: 191B1486-1#

ASSEMBLY INSTRUCTION
Queen Headboard
Queen Footboard
Eastern King/Queen Side Rails

Thank you for purchasing this quality product. Be sure to check all packing material carefully for small Hardware which may have come loose inside the carton during shipment. Identify and count all hardware and compare with the hardware list below

! It is recommended to install protective pads under all legs and supports to avoid damage or scratches when placing furniture on a wood floor or other hard surface, and to limit indentation and prevent discoloration if placing on carpet.

Part List		
NO.	Description	Q'TY
1	Headboard	1PC
2a	Headboard Post RSF	1PC
2b	Headboard Post LSF	1PC
3	Footboard	1PC
4	Rails	2PCS
5	Slat Roll	13PCS
6	Slat supports	5PCS
7	Headboard support bar	1PC
8	Footboard support leg	2PCS

Hardware List In-K-1			
NO.	Description	Sketch	Q'TY
A	Flat washer Ø5/16"		10PCS
B	Bolt Ø5/16" x 1-7/8"L		10PCS
C	Allen Key 2-1/2"L		1PC
M	Plug with connector		1PC

Hardware List In-K-2			
NO.	Description	Sketch	Q'TY
D	Flat washer Ø1/4"		2PCS
E	Bolt Ø1/4" x 1-3/8"L		2PCS
F	Allen Key 2-1/2"L		1PC
G	Screw Ø4 x 1-1/4"L		26PCS

Hardware List In - 3			
NO.	Description	Sketch	Q'TY
H	Thread Bolt Ø5/16"-18 x 3-1/8"L		8PCS
I	Curved washer Ø5/16"		8PCS
J	Nut Ø5/16"		8PCS
K	Open Wrench 1/2" x 3-1/2"L		1PC

Tools Required: Please use a screwdriver for the screwdriver is not included.

Step 1

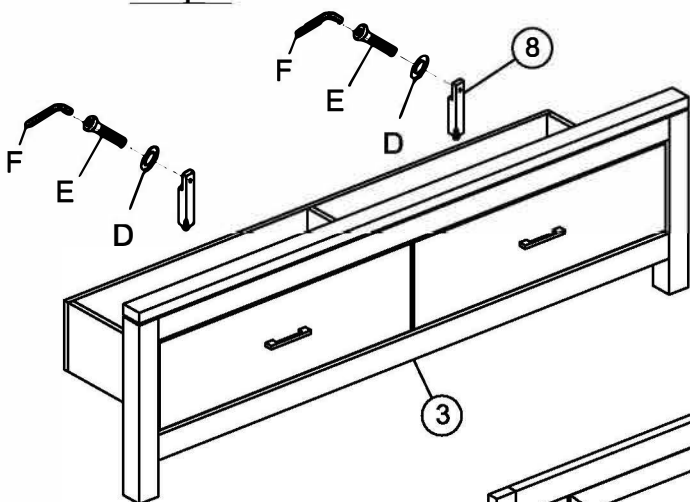

Step 2

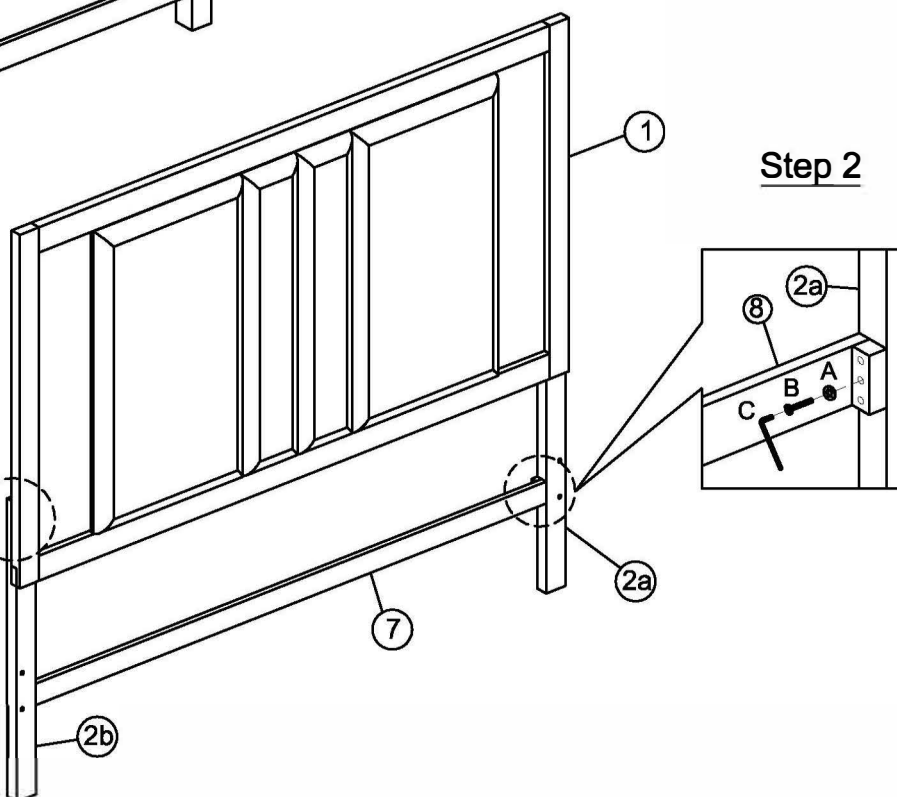

Step 3

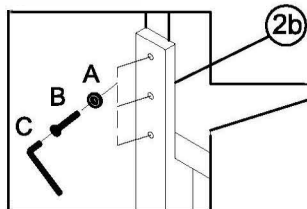

NOTE:

! Must tighten screws periodically with use. Screws will become loose, check tightness of all screws every 6-8 weeks.

ASSEMBLY INSTRUCTION
 Queen Headboard
 Queen Footboard
 Eastern King/Queen Side Rails

3 level touch up LED light

Step 4

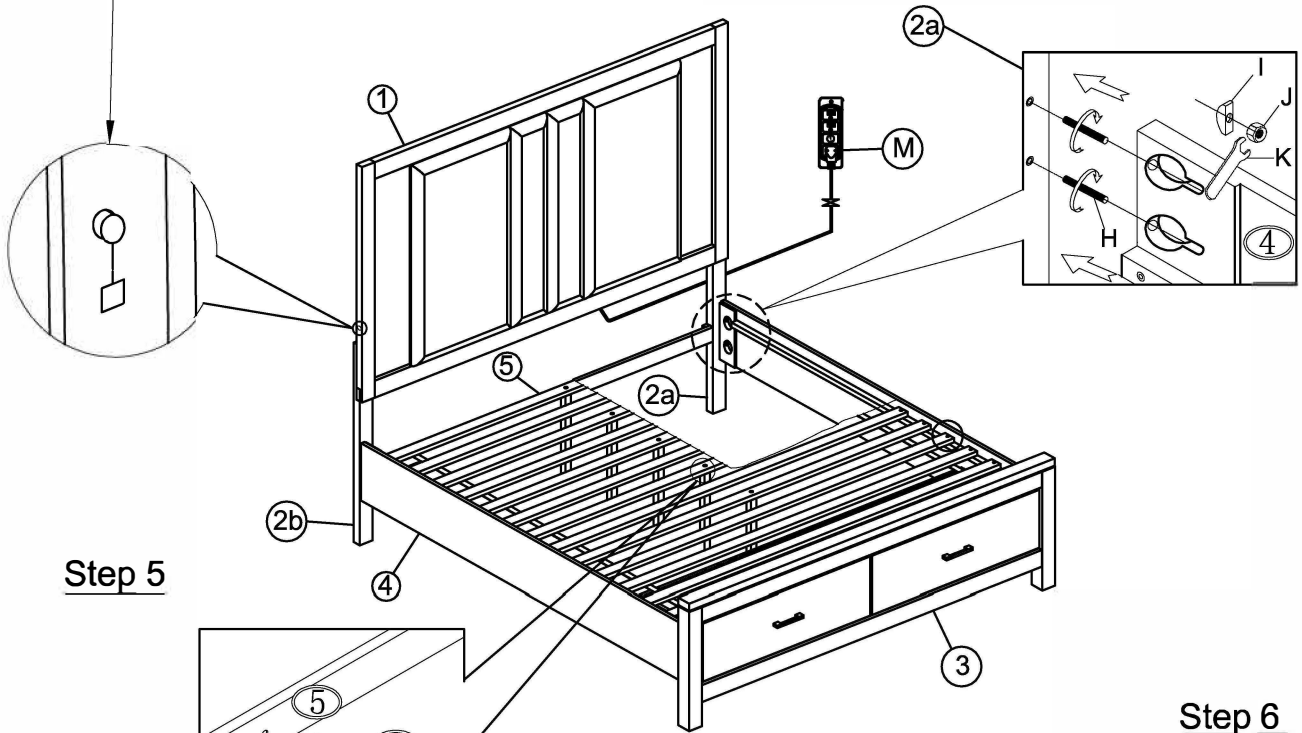

Step 5

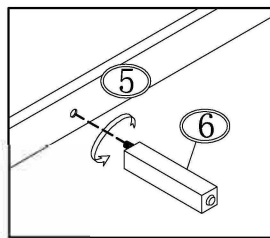

Step 6

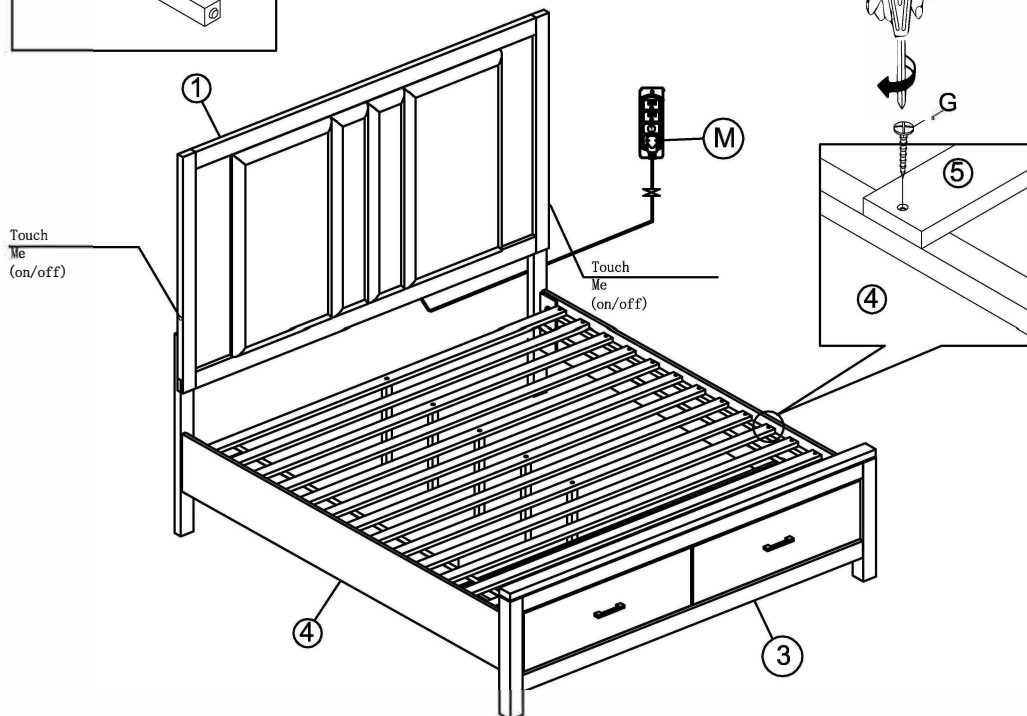

NOTE :
 DO NOT TIGHTEN BOLTS UNTIL COMPLETELY ASSEMBLED.