

This latest release from Robart incorporates several new features from our first generation control box.

- Proprietary plug design to ensure proper connections and eliminate damage caused from not using the control box.
- Status lights have been added to clearly understand the condition of the system.
- Jumpers have been replaced by DIP switches so changing settings is much easier and clear for the user.
- 2-wire design, allowing for the easy change of retract direction.

Easy to follow instructions make the installation of our Electric Series Retracts very simple, however, please read the following safety / installation tips:

- There are many pinch-points on retracts. Keep all body parts away from these as injury could occur.
- Make sure that all electric connections are tight. Loose connections can cause the retracts to be nonfunctional or erratic.
- Note the type of actuator your gear uses. The control boards have a Type A/B DIP switch to adjust the amp out point of the retract (Stopping point of the motor). Setting the wrong amp out can cause damage to actuators and gear.

### Thank You

We are pleased to have you join the Robart team with your purchase of these high-quality Electric Series Retracts.

We are confident that you will find The dependability, versatility and convenience of our Electric Series to be unmatched in the industry.

### Warranty:

One year parts, six months labor covering manufacturing defects. Warranty void if Electric Retract Controller box or actuators are opened or modified.

### Locking Extensions:

Available From Robart in 12", 24", & 36"

#177E12	12" Locking Extension (Pair)
#177E12S	12" Locking Extension (Single)
#177E24	24" Locking Extension (Pair)
#177E24S	24" Locking Extension (Single)
#177E36	36" Locking Extension (Pair)
#177E36S	36" Locking Extension (Single)



625 N. 12th Street St. Charles, IL 60174 USA

PH: (630) 584-7616 FAX: (630) 584-3712



## Robart Electric Retract Series

### Instruction Manual

*(Please Read Carefully Before Operating)*



## Installation Instructions:

1. Read the Warning & Precautions sheet thoroughly.
2. Install the retracts (Do not modify retracts).
3. See below to setup the Electric Retract Control Unit.
4. Run actuator leads from each retract to the Control Unit and plug each lead into the appropriate retract circuit. Retracts use special 2-Pin locking plug and require matching extensions available through Robart. This is to ensure the proper operation and installation.
5. Match the retract switch on your transmitter to the actual position of the gear.
6. Turn on your transmitter. Then turn on the airplane. Cycle the gear. You may have to reverse the gear channel in your transmitter or reverse the actuator lead connection. If your radio is capable, set endpoints at 100% for down and 100% for up.
7. In some installations, one retract may work opposite of the other mechanisms. In this case, flip the orientation of the actuator plug in the retract control board.
8. Power off when not in use and during DIP switch/ connection changes or when working on gear doors or control surfaces.

## Control Unit Setup:

1. The Control Unit has three actuator circuits, UNIT 1-3. Position the Type A / B DIP switch appropriately for each individual actuator type (see box to the right).
2. If you wish to have one or more retracts delay /stagger, position the "Delay" DIP switch to the "Checked" Position.
3. Position the Control Unit near your receiver and secure in some fashion (Silicone tape / Velcro).
4. Plug the provided receiver lead (male/male) from the gear channel on your receiver to the RX port on the Control Unit. Using a heavy-duty servo extension is acceptable.
5. Optional – Install an auxiliary battery in the airplane and plug into the AUX BAT port via a charging switch. An AUX BAT is recommended on larger gear. (See using an auxiliary battery instructions)
6. With proper connections made and powered on, a green status light will appear below the orange "Check".

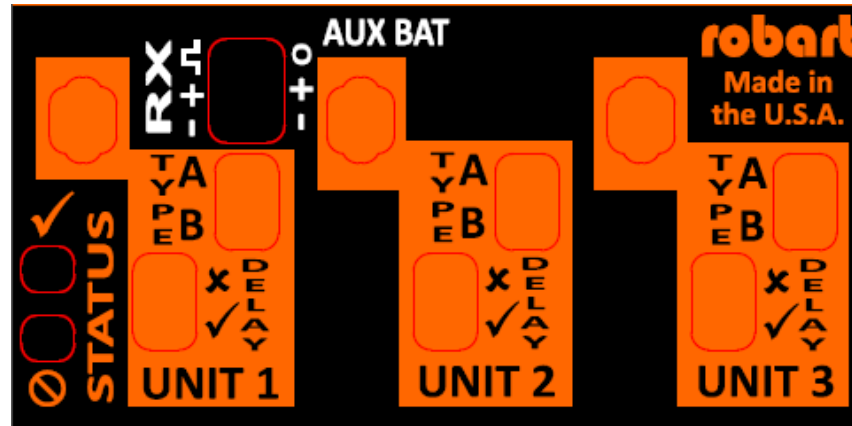

Robart Electric Retract Controller

## Amp-Out Circuitry:

The Robart Electric Series uses "Amp- Out" circuitry to sense the up/down travel limits or an obstruction such as a gear door. When the amp draw reaches a pre-programmed level, it completely shuts off the motor. Therefore, if a retract "hangs up" it will not drain the battery. If the retract amps out on an obstruction, simply use the transmitter gear switch to reverse the gear away from the obstruction.

## Why Type A and Type B:

The Robart Electric Series uses different motor amp-out settings depending on the size, weight, and geometry of the retract. Type A has a lower amp-out threshold. Typically, smaller retracts and tail wheels require Type A settings. These actuators will have a Type A sticker on the leads. All other actuators are Type B unless otherwise noted with a sticker on the leads. When using less than 6.0V, it is recommended to use Type A settings for all retracts.

**Operating Type A actuators on Type B settings can damage the actuator or retract and is not covered under warranty.**

## Using an Auxiliary Battery:

The Robart Electric Series can be run off the receiver battery or an auxiliary battery. **To use an auxiliary battery, remove the jumper (Save for future use) in the AUX BAT port and plug in the battery via a charging switch.** Take care to maintain proper polarity when plugging in all leads. The speed of the retracts is voltage dependent. If you want to increase the travel speed, use a higher voltage battery.

**Acceptable battery range of 4.8V-9.0V**

## Status Lights:

### ✓ - System Ready

This will have a green light illuminated when the control box is ready to operate. This means the receiver is connected and powered on, the AUX BAT is connected properly or jumper is in the proper position, and the system voltage is within specified range.

### ⊘ - System Not Ready

A red light will illuminate when the control box is not connected properly or the voltage of the system has dropped below a safe level. The control box will not operate when this is the only light activated. Changing DIP switches or plugs with power to the board can cause a dimly lit RED light to occur. This should clear after the gear is cycled.