

VANTAGE™

ROBERTS / GORDON®

Modulating Infrared Heater



**MODEL
CTH3**

Precise Air-to-Gas Ratio Provides Fuel Savings

- Fuel efficient operation with fully automatic or manual control of burner modulation
- Efficient and optimum combustion throughout full range of burner inputs ensured by pre-programmed burner controls that adjust both fuel and air
- System information and ease of service provided by comprehensive on-board diagnostics for fault and system status
- Burner box design with protective enclosure for controls minimizes exposure to dirt and moisture from combustion air
- Longer life provided by durable components



800.828.7450

www.robertsgordon.com

THE INDUSTRY LEADER
RADIANT
EFFICIENCY™

ROBERTS GORDON® THE EXCLUSIVE PRODUCER OF CORAYVAC™

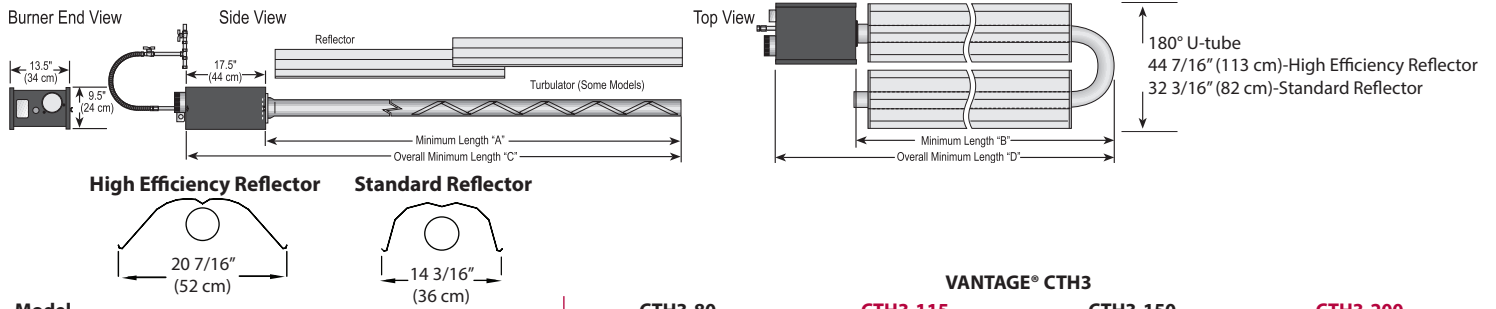

Model	VANTAGE® CTH3				
	CTH3-80	CTH3-115	CTH3-150	CTH3-200	
Minimum Length of Straight Tube*	[ft] A	20	30	40	50
Minimum Length of U-tube*	[ft, in] B	11, 7	16, 7	21, 7	26, 7
Overall Minimum Length of Straight Tube	[ft, in] C	21, 5.5	31, 5.5	41, 5.5	51, 5.5
Overall Minimum Length of U-tube	[ft, in] D	13, 0.5	18, 0.5	23, 0.5	28, 0.5

*For additional lengths, please see the current Installation, Operation and Service Manual.

Minimum Input (Btu/h) x (1000)	(NG/LP)	52/55	75/78	100/105	130/135
Maximum Input (Btu/h) x (1000)		80	115	150	200 (NG)/190 (LP)
Inlet Pressure	[in wc] NG min.	5.5	5.5	5.5	6.0
	LPG Propane min.	12	12	12	12
	NG & LPG Propane max.	14	14	14	14
Gas Connection	NPT	½"	½"	¾"	¾"
Exhaust Flue	dia	4"	4"	4"	4"
Combustion Air Inlet	dia	4"	4"	5"	5"

Weights							
Aluminized Tube and Accessory Packages	[ft]	20	30	40	50	60	70
High Efficiency Aluminum Reflector	[lb]	89	124	167	213	248	291
Standard Aluminum Reflector	[lb]	86	120	161	206	240	281
Burner	[lb]	40					
U-tube Packages							
Aluminized U-tube for High Efficiency Reflector	[lb]	23					
Aluminized U-tube for Standard Reflector	[lb]	19					

Fuel	NG or LPG Propane
Electrical Supply	120 V, 60 Hz, 1.3 A (Run) 4.8 A (Start)
Heat Exchanger Tubing	10 ft Sections, 4" dia, 16 Gauge, First 10 ft ALUMI-THERM® Steel Tubing [Remaining Heat Treated Aluminized Steel Tubing]
Reflector and End Caps	.024 Aluminum [Optional - .024 Stainless Steel Type 304]
Control System	Modulating Gas Valve and Hot Surface Electronic Ignition Control Four-Try, 100% Shut-Off, Prepurge, Post-purge, Auto Reset, Tri-Color LED Status/ Fault Indicator
Control Options	Zone Sensor, Thermostat, Modulating Thermostat, 10 K ohm Potentiometer, Remote 0-10 Vdc or 4-20 mA Signal
Approved As	Indoor (Vented or Unvented)
Certification	ANSI Z83.20/CSA 2.34
Warranty	Three-Year Limited (Refer to Installation, Operation and Service Manual for Details)

Clearances to Combustibles **[in]

Model	CTH3-80		CTH3-115		CTH3-150		CTH3-200	
	Horiz.	45°	Horiz.	45°	Horiz.	45°	Horiz.	45°
A	6	8	6	10	6	12	8	12
B	38	8	46	8	50	8	52	10
C	66	66	77	78	80	84	96	85
D	38	60	46	69	50	74	52	79

**Clearances B, C and D can be reduced by 50% for locations 25 ft (7 m) or more downstream of the burner. For other mounting options and associated clearances, complete installation, operation and service criteria, please see the current issue of the Installation, Operation and Service Manual.

This product is not for residential use.

This document is intended to assist licensed professionals in the exercise of their professional judgment.

Roberts-Gordon LLC
1250 William Street
P.O. Box 44
Buffalo, NY 14240-0044 USA
Telephone: +1.716.852.4400
Fax: +1.716.852.0854
Toll Free: 800.828.7450
www.robertsgordon.com

