

SPACEMAN^{USA}

COMMERCIAL ICE CREAM & FROZEN BEVERAGE EQUIPMENT

MACHINE MANUAL



MODEL SM-6210

SOFT SERVE - COUNTERTOP - ONE FLAVOR

Customer Service

Sunday – Saturday
8 AM – 5 PM Mountain

Toll-Free: +1 (888) 610-5520
Local: +1 (720) 328-1020

service@spacemanusa.com

Spaceman USA, LLC

226 Commerce Street
Suite B
Broomfield, CO 80020

Sales and Product Information

Monday – Friday
8 AM – 5 PM Mountain

Toll-Free: +1 (888) 610-5520
Local: +1 (720) 328-1020

sales@spacemanusa.com
info@spacemanusa.com

INTRODUCTION

WELCOME TO YOUR MACHINE:

Welcome to your Spaceman USA Model 6210 soft serve machine, engineered and designed to provide dependable operation and a consistent, quality product:

- ◆ One-flavor countertop soft serve machine with portion control
- ◆ Analog control system for automatic regulation and maximum customization
- ◆ Approved for dairy and nondairy products
- ◆ Hopper refrigeration to maintain product temperature below 40°F (4°C)
- ◆ Analog viscosity-control system to adjust and maintain product consistency

This machine manual is intended to instruct users on the installation, operation, cleaning, and routine maintenance procedures. Information contained in this manual may be subject to change. Please check online or contact Spaceman USA Technical Support at (720) 328-1020 for continued updates, training, and detailed information about your Spaceman machine.

LOOK OUT FOR THESE ICONS:



WARNING: Denotes an action that WILL cause harm to the operator or machine if performed incorrectly.



CAUTION: Informs the operator of a task that may lead to harm if protocol is not properly performed.



IMPORTANT: Represents a vital mechanical step or note that the user must be aware of.



NOTE: Non-hazard, but pay extra attention.

Green boxes throughout the manual represent instructions for machines with air pumps. Users without air pumps can disregard these boxes.

FOLLOW INSTRUCTIONS TO BE SAFE:



CAUTION: This machine has many built-in safety features to protect the operator while the machine is running.

Be cautious and follow instructions carefully when operating, cleaning, and servicing the machine.

All personnel operating this machine **MUST** read and understand this manual in its entirety. Failure to comply with this manual may damage the machine and cause severe injury to the operator.

TABLE OF CONTENTS

WHAT DO YOU WANT TO DO?

Learn about the manual	1
Quickly refresh your knowledge on basic machine operation and parts	3
Ensure installation requirements	5
Unpack machine	6
Perform routine maintenance	7
Clean	8
Drain frozen product	8
Disassemble parts	9
Wash parts	11
Assemble parts	13
Sanitize	15
Manage frozen product	17
Add product to machine	17
Freeze product	18
Dispense product	18
Reset machine after freeze-up	18
Use STANDBY mode for breaks in machine use	19
Adjust and maintain product consistency	19
Change product temperature in hoppers	20
Change date and time	20
Adjust advanced settings	20
Troubleshoot problems	21
View machine specifications, including parts and wiring diagrams.....	23

QUICK OPERATION REFRESH



WARNING: The Quick Operation Refresh is for experienced 6210 operators and for reference **ONLY**. Detailed start-up instructions **MUST** be followed to ensure proper installation, cleaning, and operation of the machine. Failure to do so may result in **severe** damage or injury.

INSTALLATION AND SETUP

1

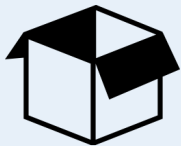

Unpack and inspect machine, parts, and accessories.

2



Place machine in appropriate food preparation area. Comply with all installation requirements (Page 7).

3

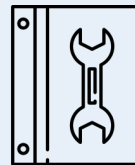

Read and understand ALL safety and standard operating procedures.

CLEANING AND PREPARATION

4



Fully disassemble machine, and prepare parts for cleaning.

5



Thoroughly clean and scrub machine hoppers, cylinders, and all parts.

6



Lubricate and re-assemble all machine parts.

7



Fully sanitize machine.

OPERATION

8



Prepare product in a separate container, and ensure product is thoroughly mixed.

9



Add product to hoppers and prime the cylinder using the prime plug.

10



Turn machine to FREEZE mode, and wait for product to reach frozen consistency.

11



Slightly adjust viscosity setting as necessary to adjust product firmness.

QUICK OPERATION REFRESH

MACHINE PARTS

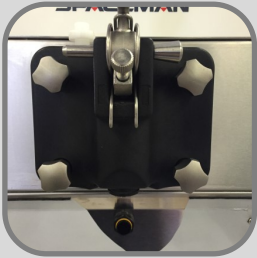

Dispensing Door Assembly (1), with included parts:



Star Cap (1)



Beater Rod (1)



Gasket (1)



Beater Guide (1)



Draw Handle (1), with Adjusting Screw (1)



Hand Screws (4)



Prime Plug (1), with O-Rings (2)



Retention Pin (1), with Nut (1)



Draw Valve (1), with O-Rings (2)



Beater (1)



Scraper Blade Clips (2)



Scraper Blades (2)



Beater Shoes (1 Left and 1 Right)



Hopper Agitator (1) (if included)



Drive Shaft (1)



Drive Shaft Gasket (1)



Hopper Lid (1)



Air Tube (1) and Cap (1)



O-Ring Removal Tool (1)



Brush Kit (1)



Internal Drip Tray (1)



Front Drip Tray (1), with Splash Shield (1)



Air Pump Assembly (1) (if included)

INSTALLATION REQUIREMENTS

ELECTRICAL REQUIREMENTS

In the United States, it is required that this machine be installed in compliance with the National Electrical Code (NEC), ANSI/NFPA 70-1987 to practically safeguard persons and property from hazards arising from the use of electricity. The unit must be installed into a properly grounded receptacle for the cord and plug provided. The machine is labeled with detailed electrical specifications. Refer to the wiring diagrams for the correct power connections.

REFRIGERANT REQUIREMENTS

Spaceman USA requires that only the specified refrigerant be used in your machine. Alternative refrigerants may cause damage to the cooling system and/or prevent the machine from operating at optimal performance. If you require an alternative refrigerant, please call Spaceman USA Technical Support for a list of compatible alternatives for your compressor.

Main compressor: 1x 2450 BTU, R404A

MACHINE PLACEMENT REQUIREMENTS



CAUTION: The machine must be placed on a level surface away from walls and other objects. Failure to comply will damage the machine and refrigeration components and will void all warranties.



CAUTION: The machine is designed to operate in normal ambient temperatures of 60 to 75°F. Operating in higher ambient temperatures will result in degraded performance.

- ◆ Place on a flat, level, and solid surface fitted to the machine dimensions.
- ◆ Ensure a minimum 6-inch clearance on all sides, front, and back.
- ◆ Completely clear area of dust, grease, and airborne particles.
- ◆ Place away from hot equipment such as stoves, frying baskets, ovens, etc.

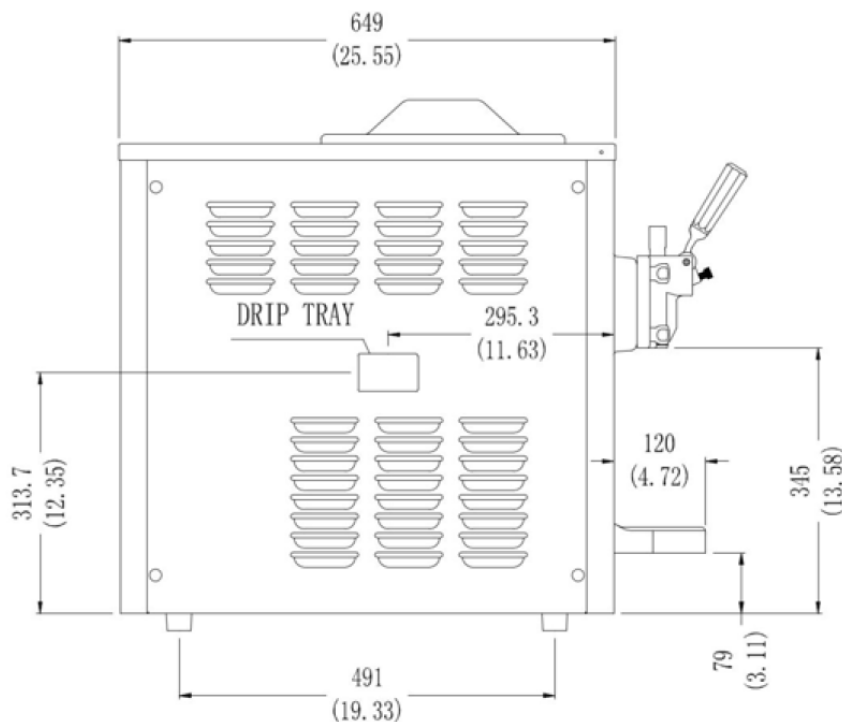

1. UNPALLETIZE MACHINE

Unpalletizing requires lifting.



Two or more personnel should remove the machine from its packaging and place it in its final operating location.

Failure to do so may result in severe injury or damage.

1. Cut packing straps, and remove cardboard lid and outer sides from the pallet. **DO NOT** cut cardboard.
2. Remove plastic wrapping around machine.
3. Cut stabilizing straps, being careful not to scratch or dent the machine panels.
4. Prepare the table or stand that the machine will be placed on.
5. If the table or stand has casters, lock all casters prior to setting the machine on top.
6. Place the machine on top of the stand, countertop, or table.
7. Place the machine in its final location according to the Installation Requirements (Page 5).

2. CHECK FOR SHIPPING DAMAGE

Inspect the machine for any shipping damage. If you find any, contact Spaceman USA Technical Service immediately after unpalletizing. Our technicians will help you assess the damage and determine the appropriate action prior to accepting the delivery.

3. UNPACK AND INSPECT PARTS

Refer to the detailed parts diagrams on the back pages if necessary.

1. Remove all packaged parts and accessories from your machine.
2. Organize items on a clean table or operating area using the checklist below.

- Hopper Lid
- Front Drip Tray + Splash Shield
- Dispensing Handle
- Retention Pin with Nut
- Start-Up Kit
- Brush Kits (1 Large and 1 Small)
- Machine Manual

3. Inspect for damage immediately upon unpacking, and call Spaceman USA Technical Service if you discover any damaged or missing parts.
4. Clean and properly lubricate machine parts prior to machine operation.

After unpacking and inspecting the parts, you are ready to disassemble the machine and prepare for the first operation. **Read about Routine Maintenance (Page 7) carefully prior to disassembling your machine for the first time.**

ROUTINE MAINTENANCE

ROUTINE MAINTENANCE OPERATIONS:

- ◆ **Clean and Lubricate** Daily
- ◆ **Replace Wearable Parts** Every 1 to 3 months*
- ◆ **Internal Cleaning** Quarterly**

* Based on machine usage and cleaning intervals; a Tune-Up Kit is available with all wearable parts (O-rings, gaskets, etc.) except scraper blades

** Based on cleanliness of location and proximity to powder-based machines

For optimal machine performance and many years of efficiency and reliability from your machine, Spaceman USA recommends cleaning and sanitizing the machine and its parts **daily**. The machine comes equipped with a brush kit specifically designed to efficiently and properly clean the machine.



Tune-Up Kit



WARNING: If this is the first time operating the machine, you **MUST** clean and sanitize **ALL** parts prior to running the machine.



IMPORTANT: Cleaning and sanitizing schedules are governed by state or local regulatory agencies and **MUST** be followed accordingly. Routine maintenance **MUST** be performed a minimum of once every three days.



CAUTIONS:

- ◆ Do **NOT** run the machine without properly lubricating required parts.
- ◆ Do **NOT** clean the machine with abrasive or toxic chemicals and cleaners. Doing so may cause damage to the stainless steel material.
- ◆ **ONLY** use Spaceman-USA-included cleaning brushes and lubrication.
- ◆ **NEVER** use metal objects to clean or operate the machine.
- ◆ **ALWAYS** replace wearable parts a minimum of every 3 months.
- ◆ **ALWAYS** prime machine prior to operating.
- ◆ **ALWAYS** inspect parts for excess wear and damage.



NOTE: Additional brushes, lubrication, wearable parts, and tools can be purchased from Spaceman USA to ensure proper maintenance. Extra wearable parts (except scraper blades) are found in the Start-Up Kit.

CLEANING: 1. DRAIN PRODUCT



NOTES: To expedite draining, turn off machine 30 minutes prior to soften product.
To expedite process, keep a bucket nearby to temporarily store removed parts.



CAUTION: Never use warm water when rinsing the machine to prevent damage.

1. Remove hopper lid and air tube
2. Place a bucket or other container below dispensing assembly
3. Turn power switch to WASH
4. Move draw handle to OPEN position (DOWN); CLOSE draw handle (UP) when product flow slows significantly
5. Turn power switch to OFF
6. Remove product and dispose or refrigerate it
7. Fill hopper with one gallon of COOL water
8. Use cool water and the large brush to scrub the sides and bottom of the hopper; *be VERY careful not to damage the low-mix sensor in the hopper*
9. Place a bucket or other container below the dispensing assembly
10. Turn the power switch to WASH
11. OPEN draw handle to drain water and remaining product; CLOSE when finished
12. Use the small brush kit to clean inside the feed tube at the bottom of the hopper;
13. Turn the power switch to OFF
14. Repeat steps 7 to 13 until water exiting the draw valve is clear and free of product

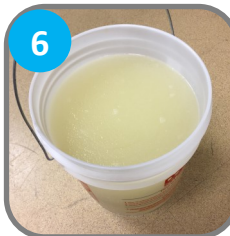
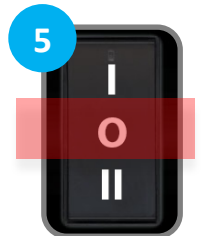

CLEANING: 2. DISASSEMBLE



NOTE: Prepare dishwashing area prior to disassembly, use bucket to temporarily store large removed parts and a small container for O-rings, and have a towel nearby to capture excess water.



CAUTION: Always separate O-rings and gaskets from metal parts to prevent damage while washing.

1. Turn power switch OFF



2. Remove dispensing door

- Remove dispensing-door hand-screws (4)
- Remove dispensing door assembly from cylinder

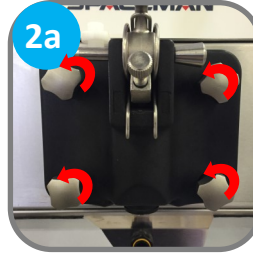

3. Disassemble dispensing door

- Remove beater guide from door assembly; remove gasket from door assembly using O-ring removal tool
- Remove prime plug from door assembly; remove O-rings (2) from prime plug using O-ring removal tool
- Remove retention pin
- Remove draw handle, pushing down first to pop up draw valve, then pulling out
- Remove draw valve, *twisting while removing to prevent damage*
- Remove O-rings (2) from draw valve using O-ring removal tool
- Rotate star cap so that tab is accessible; snap off star cap

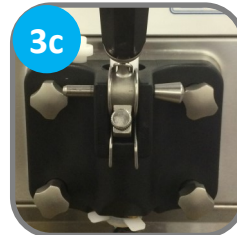

CLEANING: 2. DISASSEMBLE

4. Disassemble beater assembly and drive shaft

- Remove beater assembly from cylinder
- Remove scraper blades (2) from beater assembly; separate scraper blade clips (2) from scraper blades
- Pull off beater shoes (2)
- Remove drive shaft from inside cylinder using a dry towel; separate gasket from drive shaft



NOTE: If you experience assembly difficulty with drive shaft, Spaceman offers a specialized removal tool for purchase.

5. Remove internal drip tray and front drip tray + splash shield



CLEANING: 3. WASH ALL PARTS

CAUTION: Never wash parts in a dishwasher. Always hand-wash components with nontoxic, food-safe cleaners.

1. Verify power switch is in the OFF position
2. Use the large brush and cool water to thoroughly clean inside the cylinder; *be sure to scrub the back of the cylinder and verify the cylinder is free of ALL product*
3. Thoroughly clean and dry the rear of the cylinder with the supplied black brushes and a clean, dry towel
4. Gently clean and wipe down the outside of the machine
5. Carefully and thoroughly wash all parts removed from the machine using supplied brushes, sponges, and clean towels; *if machine has air pump, be sure to include all air pump parts in cleaning*
6. When cleaning the dispensing door assembly, clean the priming port with a small brush
7. Carefully and thoroughly clean all gaskets and O-rings removed from the machine; *be sure to wipe gaskets and O-rings to remove excess lubricant*
8. Verify all parts are clean and free of all food product prior to re-assembling machine



CLEANING: 4. ASSEMBLE



CAUTION: Never force the installation of any parts. All parts fit correctly without force. If parts don't seem to fit, remove all parts and repeat assembly.

1. Verify power switch is in the OFF position

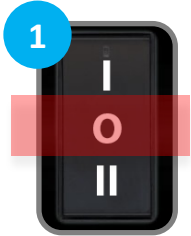

2. Install drive shaft

- Place drive shaft gasket on drive shaft
- Seal gasket open space with Spaceman lubricant, extending onto drive shaft and *avoiding the top square part*



- Insert drive shaft into rear shell bearing at the back of the cylinder, and turn it until the key engages firmly into the socket (when inserted correctly, the drive shaft will no longer turn 360°)

3. Install beater assembly

- Attach beater shoes (2) onto beater; when properly placed, neither shoe overhangs beater edge
- Install scraper blade clips (2) onto scraper blades (2)
- Fit scraper blades onto beater
- Insert beater assembly into cylinder, *making sure beater shoes stay in place*; turn assembly until it engages the drive shaft key and no longer turns 360°

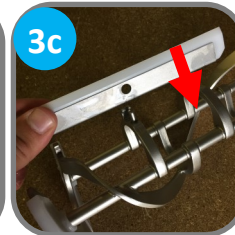
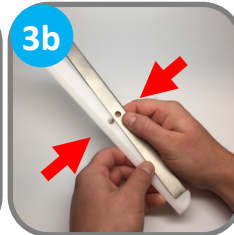

CLEANING: 4. ASSEMBLE

4. Install dispensing door

- a. Place O-rings (2) on draw valve; place O-rings (2) on prime plug; coat all ring areas with Spaceman Lubricant
- b. Push prime plug into hole on top of dispensing door
- c. Insert draw valve into dispensing door, O-rings-first
- d. Set draw handle into slot on dispensing door, with adjustment screw facing down
- e. Slide retention pin through draw handle; secure with nut
- f. Snap star cap onto bottom of dispensing door
- g. Fit gasket into grooves on back of door, flat side out; slide beater guide over beater rod, with flanged edge against the door
- h. Insert dispensing door assembly into cylinder, beater rod first, pushing handle all the way up as you insert
- i. Secure door assembly in a cross-pattern using hand-screws (4)



6. Install hopper lid and drip trays

- a. Install internal and front drip trays
- b. If machine will be left unused, install air tube and place hopper lid on top; otherwise, set air tube aside until after machine has been primed



SANITIZATION

IMPORTANT: After sanitizing the machine, DO NOT rinse or touch areas that have been sanitized. Product must be added immediately. If new product will not be added immediately, rinse machine with clean water and loosen door hand-screws to allow cylinder to air-dry. Sanitize machine before using again.

CAUTION: Always use food-grade, no-rinse sanitizer to sanitize. If warm water is required to dissolve sanitizer, allow the solution time to cool before adding to machine.

1. Verify assembly is complete
2. If installed, remove hopper lid and air tube
3. Verify draw valve is in the CLOSED position (UP)
4. Mix a minimum of 2 gallons of food-grade sanitizer in a bucket or container
5. Pour half the food-grade sanitizer solution into hopper
6. Turn power switch WASH
7. Allow solution to agitate for 5 to 10 minutes; *NEVER leave machine on WASH for more than 10 minutes*
8. While agitating, gently use a clean brush to scrub and distribute sanitizer solution along hopper walls
9. Place a bucket or container below the draw valve
10. OPEN the draw valve (DOWN) and drain solution from the machine
11. Press RESET button to stop cycle

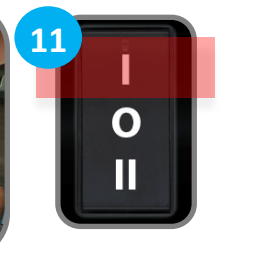
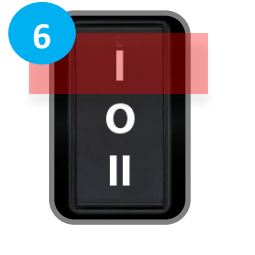

FROZEN PRODUCT OPERATION

ADD PRODUCT TO MACHINE



NOTE: The mix-low lights illuminate **RED** when a hopper is low on product mix and automatically de-illuminate when machine is filled.



1. Verify machine has been recently sanitized (within 1 hour); if machine has not been recently sanitized, verify door hand-screws are tight, and perform sanitizing steps (Page 15)
2. Thoroughly mix and prepare at least 2 gallons of product according to manufacturer instructions; mix should be cool and smooth (free of large chunks)
3. Place bucket or large container below draw valve
4. Pour 0.25 gallons of product into hopper
5. OPEN draw handle (DOWN); sanitizer will start to flow out draw valve
6. Once sanitizer has been purged from the machine and a steady stream of product is flowing from the spout, CLOSE draw handle (UP)
7. Pour remaining product into hopper
8. Raise the prime plug on the top of the dispensing door until flow is 100% product
9. Push prime plug back down
10. Wash air tube and cap; install air tube in hopper (inlet hole on side of air tube at bottom)
11. Replace hopper lid
12. Product is now ready to freeze



FREEZE PRODUCT



CAUTION: *Never* disconnect air pump (if present) with the machine running. If disconnecting air pump, *first* switch machine to OFF to stop operations and open draw handles for 10 to 15 seconds to relieve pressure in cylinder.

1. Verify cylinder is full of mixed product and primed
2. Turn power switch to FREEZE position
3. The motor will begin to agitate the product, and the cooling system will begin to freeze the product
4. Freezing product takes approximately 10 minutes
5. When product reaches the set viscosity, it is ready to dispense (viscosity can be changed in the Settings menu, Page 19)

FROZEN PRODUCT OPERATION

DISPENSE PRODUCT



CLOSED

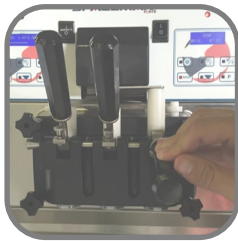

OPEN



1. OPEN draw handle (DOWN) until desired amount is dispensed
2. CLOSE draw handle (UP) when finished dispensing

Adjustment screws below draw handles control dispensing speed.

- Tighter (clockwise) reduces speed
- Looser (counter-clockwise) increases speed

MACHINE POWER RESET

IMPORTANT: Machine shuts down automatically if cylinder experiences freeze-up (usually because the viscosity is set too high for the selected product) to prevent motor damage. Use the green reset button to return the machine to normal operation.



Proper Machine Reset

1. Switch power switch OFF
2. Press green reset button on side or back of machine
3. Wait 15 to 20 minutes; switch power ON
4. Press RESET, then WASH button on front
5. Observe machine performance and return to normal use if functioning properly



CAUTION: If machine makes any abnormal noise during reset, immediately switch power OFF and contact service



NOTE: If machine doesn't turn on, turn power OFF, wait 30 minutes, and repeat steps 1 to 5. If problem persists, contact service team.

FROZEN PRODUCT OPERATION

ADJUST PRODUCT CONSISTENCY

IMPORTANT: Make only small adjustments to viscosity setting; allow at least 10 to 15 minutes between adjustments to evaluate product firmness. Viscosity setting should not need continuous adjustment. A setting of 3 is a good starting point for most product

Viscosity Adjustment:

1. Remove Left Side Panel using 6mm Allen Wrench
2. Remove Electrical Box Cover using 7mm Wrench
3. Viscosity is adjusted on the Electronic Control Board
4. Move the switch UP for the desired viscosity level. Move all other switches DOWN.
5. The hardest viscosity is switch 1. The softest viscosity is switch 6.

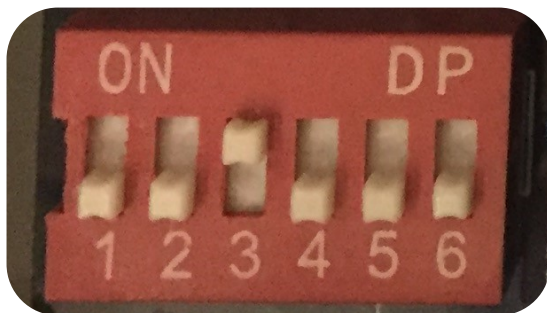

Harder

Softer

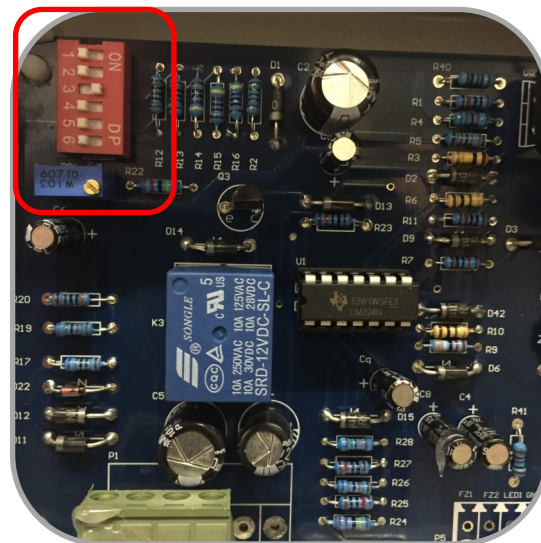

MAINTAIN PRODUCT CONSISTENCY

Machines without air pumps can experience product consistency changes if they go unused for an extended period of time. Product may become icy or dense if left in the freezing cylinder too long, often occurring during a business's longer slow-periods.

1. With machine in FREEZE mode, remove air tube
2. Clean air tube and insert into machine upside-down (inlet hole on the side of the air tube at the top)
3. Confirm product is above low-mix line in hopper
4. Open draw handle to draw 6 to 8 oz. of product; discard product
5. Wait until machine finishes freeze cycle and motor stops turning
6. Remove and clean air tube
7. Insert air tube into machine with correct orientation (inlet hole on the side of the air tube at the bottom)
8. Machine is ready for normal operation



TROUBLESHOOTING

PROBLEM: HOPPER ISN'T COLD ENOUGH

Probable Cause

1. Warm product was recently added
2. Hopper temperature setting is too high
3. Temperature offsets need adjustment

Remedy

1. Allow at least 1 hour after adding new mix for hopper temperatures to stabilize
2. Adjust hopper temperature warmer (Page 20)
3. Call Spaceman Technical Support

PROBLEM: HOPPER IS FREEZING

Probable Cause

1. Inadequate mix in hopper
2. Hopper temperature setting is too low

Remedy

1. Ensure hopper is at least half full
2. Adjust hopper temperature warmer (Page 20)

PROBLEM: PRODUCT IS TOO SOFT

Probable Cause

1. Machine isn't cleaned/lubricated adequately
2. Inadequate mix in hopper
3. Improper mixing of product
4. Machine doesn't have adequate ventilation
5. Viscosity adjustment is set incorrectly

Remedy

1. Clean and properly lubricate machine daily
2. Ensure hopper is at least half full
3. Follow manufacturer instructions for mixing product; ensure correct mix ratios
4. Ensure at least 6-in. clearance on all sides
5. Raise viscosity setting as required (Page 19)

PROBLEM: STOP 1—LOW TEMP PROTECT

Probable Cause

1. Inadequate mix in hopper
2. Improper mixing of product
3. Air tube isn't installed correctly
4. Viscosity adjustment is set incorrectly
5. Product is being drawn too quickly

Remedy

1. Ensure hopper is at least half full
2. Follow manufacturer instructions for mixing product; ensure correct mix ratios
3. Clean air tube, ensure proper orientation
4. Lower viscosity setting as required (Page 19)
5. Ensure air tube isn't clogged, allow machine 2 to 3 seconds between servings

PROBLEM: STOP 2—MOTOR OVERLOAD

Probable Cause

1. Viscosity adjustment is set incorrectly
2. Inadequate mix in hopper
3. Improper mixing of product
4. Air tube isn't installed correctly
5. Product is being drawn too quickly

Remedy

1. Lower viscosity setting as required (Page 19)
2. Ensure hopper is at least half full
3. Follow manufacturer instructions for mixing product; ensure correct mix ratios
4. Clean air tube, ensure proper orientation
5. Ensure air tube isn't clogged, allow machine 2 to 3 seconds between servings to recover

PROBLEM: STOP 4—TEMPERATURE

Probable Cause

1. Malfunctioning temperature probe

Remedy

1. Replace temperature probe

PROBLEM: STOP 6—MOTOR AMP

Probable Cause

1. Malfunctioning power board

Remedy

1. Replace power board

PROBLEM: MACHINE IS MAKING NOISE

Probable Cause

1. Improper assembly
2. Wearable parts need replacement
3. Internal cleaning/maintenance required
4. Damaged internal parts

Remedy

1. Stop machine use, drain product with machine powered OFF; clean and inspect parts.
2. Replace wearable parts (including scraper blades) at least once every 3 months
3. Contact Spaceman USA Technical Support
4. Inspect parts carefully for damage, ensure proper assembly; replace as required

PROBLEM: PRODUCT LEAKS EXCESSIVELY INTO INTERNAL DRIP TRAY

Probable Cause

1. Improper or inadequate lubrication of drive shaft gasket
2. Damaged, missing, or improperly installed drive shaft gasket

Remedy

1. Use sufficient food-grade lubricant, and add sufficient lubricant inside drive shaft gasket during assembly (Page 13)
2. Replace drive shaft gaskets every 1–3 months

PROBLEM: PRODUCT LEAKS EXCESSIVELY FROM DISPENSING DOOR SPOUT

Probable Cause

1. Improper or inadequate lubrication of draw valve and draw valve O-rings
2. Cracked, broken, or worn draw valve O-rings

Remedy

1. Use sufficient food-grade lubricant when assembling draw valves (Page 13)
2. Replace O-rings every 1-3 months

PROBLEM: MACHINE SHUTS DOWN AUTOMATICALLY

Probable Cause

1. Cylinders are experiencing freeze-up (usually due to viscosity being set too high for selected product)

Remedy

1. Reset machine (Page 18), and lower viscosity as required (Page 19)

MACHINE SPECIFICATIONS

SM-6210

SOFT SERVE FREEZER

PRODUCT INFORMATION

Type	Counter Top
Flavors	1
Cooling	Air Cooled
Freezing Cylinders	1x 1.2 L / 1.3 qt
Product Mix Hoppers	1x 8.0 L / 8.5 qt
Output (4oz Servings)	12.75 qt / hr 101 servings / hr
Motor	1x 0.6 HP, 450W
Compressor (Main)	1x 2450 BTU, R404A
Compressor (Auxilliary)	Solenoid

FEATURES

Machine Controls	Single, Analog
Refrigerated Hopper	Yes, Analog Control
Hopper Agitator	No
Temperature Display	No
Standby Mode	No
Low Mix Indicator Light	Yes
Low Mix Indicator Alarm	No
Low Temperature Protection	No
Motor Amperage Protection	Yes, Mechanical
High Pressure Protection	Yes
Thermal Overload Protection	Yes



DESCRIPTION

A single flavor, gravity feed, countertop soft serve freezer. Capable of producing a variety of products including: Soft Serve, Frozen Yogurt, Ice Cream, Custards, and Sorbets. Analog control system makes for an excellent low-cost offering while maintaining excellent product consistency. Refrigerated hopper keeps product fresh and is approved for dairy or non-dairy products.

CUSTOM OPTIONS

Air Chute, Spinner (1)

ELECTRICAL SPECIFICATIONS

	Maximum Fuse Size	Min. Circuit Ampacity	Poles (P) Wires (W)
110-115/60/1	1 x 20A	1 x 14A	2P / 3W

Electrical Plug: 1x NEMA 5-20

SIZE SPECIFICATIONS

	Machine		Shipping	
Weight	86 kg	191 lbs	96 kg	213 lbs
Depth (mm / in)	649*	25.6*	800	31.5
Width (mm / in)	384*	15.2*	460	18.2
Height (mm / in)	691	27.2	840	33.07

Shipping Volume: 0.31 CBM / 10.92 CBF

* Machine Requires Minimum 6" Clearance on all sides

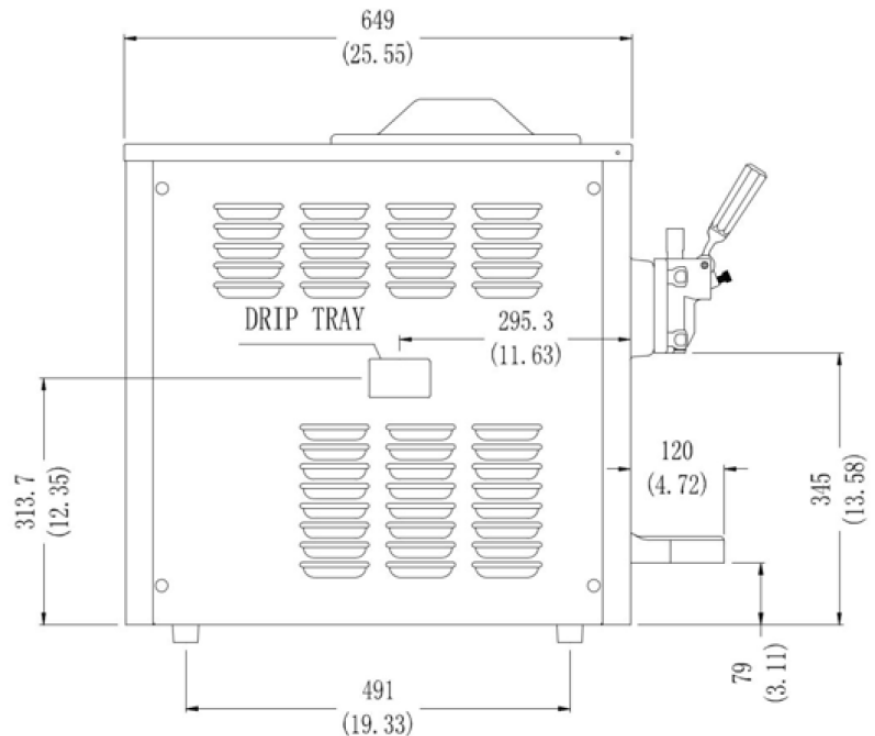
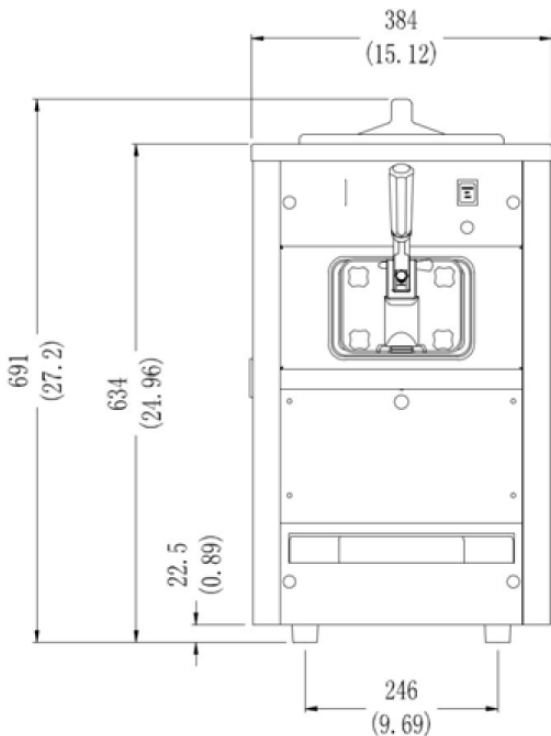

Exterior Parts

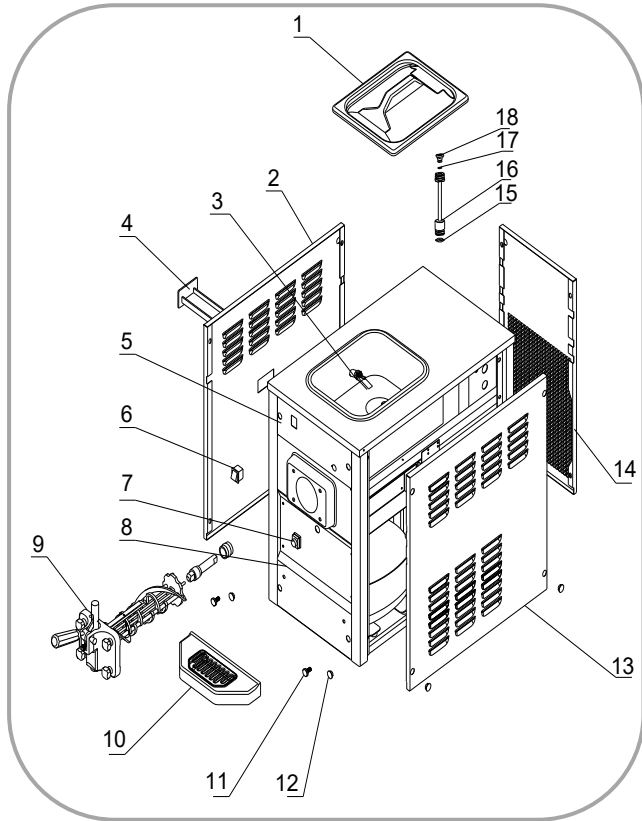

Interior Parts

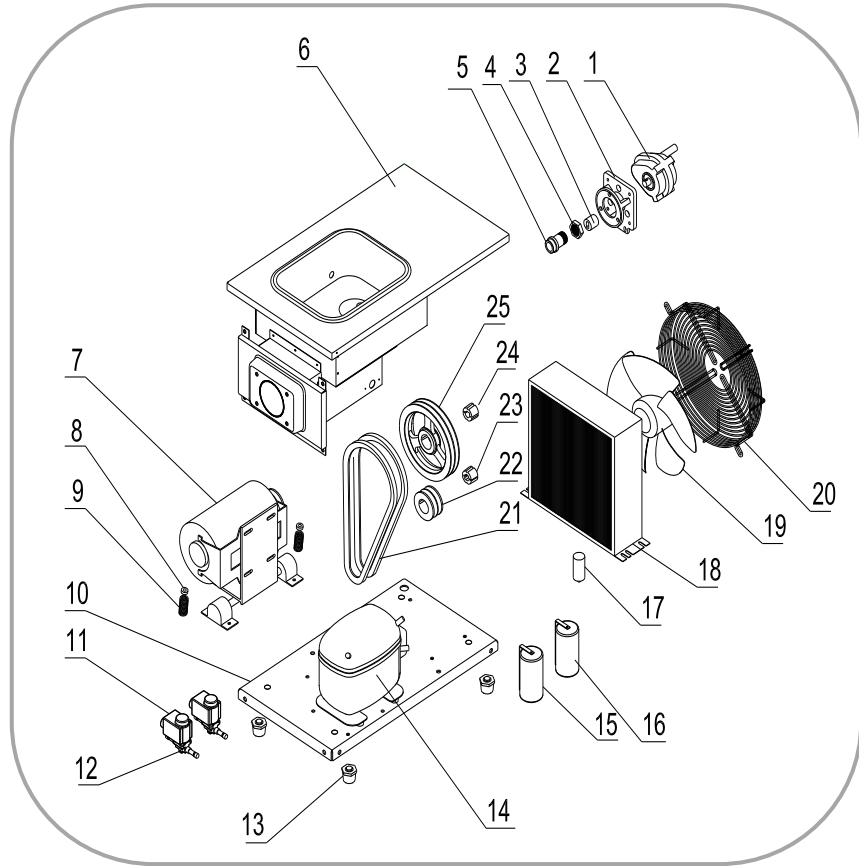

Item	Part #	Description
1	3.4.03.01.001	Hopper Lid
2	2.3.4.28.004	Panel - Left
3	3.1.03.04.009	Low Mix Sensor
4	3.4.04.02.003	Internal Drip Tray
5	2.3.4.08.007	Panel - Front - U
6	3.1.03.03.002	Power Switch
7	3.1.03.04.011	Draw Sensor
8	2.3.4.27.006	Panel - Front - L
9	2.1.1.15.0017	Dispensing Door
10	3.4.04.01.005	Drip Tray
11	3.6.39.004	Drip Tray Mount
12	3.4.07.01.001	Bolt Cover
13	2.3.4.30.004	Panel - Right
14	2.3.4.23.004	Panel - Rear
15	3.4.08.01.002	O-Ring
16	2.1.1.22.0002	Air Tube
17	3.4.08.01.028	O-Ring
18	2.1.3.23.0001	Air Tube Cap

Item	Part #	Description
1	3.3.02.01.002	Gear Box
2	2.1.3.15.0002	Gear Box Mount
3	3.3.02.04.001	Coupling Drive
4	3.3.02.02.010	Nut - RS Bearing
5	3.3.02.02.001	Rear Shell Bearing
6	2.1.1.01.0024	Hopper & Cylinder
7	3.3.01.07.010	Motor - 450W
8	3.4.08.04.001	Motor Mount
9	3.6.03.002	Motor Dampening
10	2.2.4.01.0020	Chassis
11	3.2.04.04.016	Solenoid Coil
12	3.2.04.04.001	Solenoid Body
13	3.3.05.03.001	Leg

Item	Part #	Description
14	3.2.01.02.038	Compressor
15	3.1.02.22.010	Capacitor - Running
16	3.1.02.22.063	Capacitor - Start
17	3.2.03.04.003-2	Capacitor - Fan
18	3.2.02.01.003	Condenser
19	3.2.03.04.003	Fan Motor
20	3.2.03.04.003-1	Fan Cover
21	3.3.03.03.007	Belt - A813
22	3.3.04.02.003	Pulley - 71x2-1108
23	3.3.04.01.006	Bushing - 1108
24	3.3.04.01.005	Bushing - 1008
25	3.3.04.02.007	Pulley - 182x2-1008

Dispensing Door and Beater

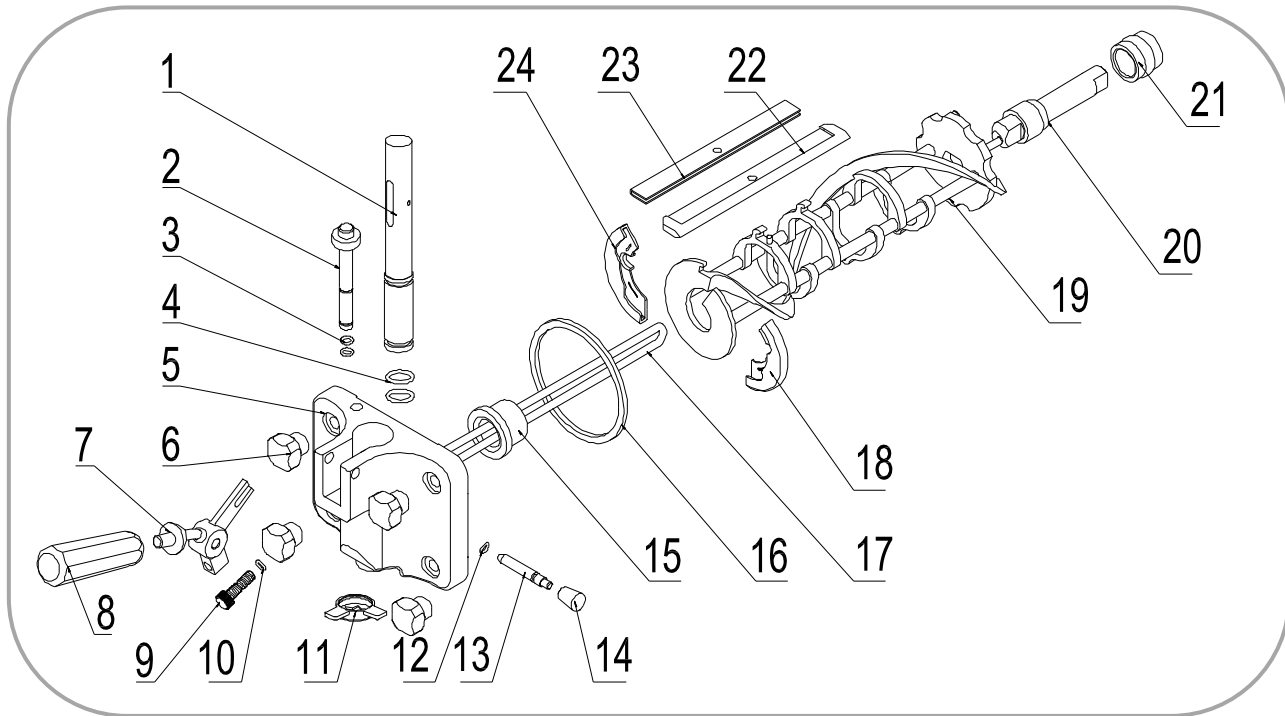

Item	Part #	Description	Item	Part #	Description
1	2.1.3.01.0002	Draw Valve	13	2.1.3.27.0001	Retention Pin
2	2.1.3.02.0015	Prime Plug	14	2.1.3.27.0025	Nut - Retention Pin
3	3.4.08.01.013	O-Ring - Plug	15	3.4.01.03.001	Beater Guide
4	3.4.08.01.006	O-Ring - Valve	16	3.4.08.01.029	Door Gasket
5	2.1.3.14.0002	Dispensing Door	17	2.1.1.11.0003	Beater Rod
6	2.1.3.32.0001	Hand Screws	18	3.4.01.02.002	Beater Shoe - R
7	2.1.3.26.0004	Handle Seat	19	2.1.1.10.0008	Beater
8	3.4.05.01.001	Dispensing Handle	20	2.1.3.25.0001	Drive Shaft
9	3.6.39.009	Adjustment Screw	21	3.4.07.05.002	Drive Shaft Gasket
10	3.4.08.01.012	O-Ring - Screw	22	3.4.02.01.003	Scraper Blade
11	3.4.05.03.004	Star Cap	23	2.3.4.04.003	Scraper Blade Clip
12	3.4.08.01.013	O-Ring - Pin	24	3.4.01.01.002	Beater Shoe - L

