



### Performances

1160.6PAG/PAiG

#### DESIGN

The Performances range of rotisseries has been especially designed for high-volume cooking with high output and speed, while retaining excellent cooking quality. Well designed, user friendly and reliable the Performances is used by leading super-markets and chain restaurants throughout the world.

Conscious of the high energy cost involved for our clients, the Performances rotisserie has energy saving infrared burners, patented by Rotisol. A wide array of accessories enable the rapid roasting of a variety of products.

#### FEATURES

- Energy efficient
- Tempered K-glass doors
- Independent motor for each spit
- Equipped with bottom drip tray with built-in drainage
- Rotisol patented burners
- Powerful halogen lamp
- Delivered with 6 spatchcock spits (BCR1160)
- Optional Illuminated sign «Rotisserie»
- Optional base on casters with brakes must be purchased unless installing on a food truck

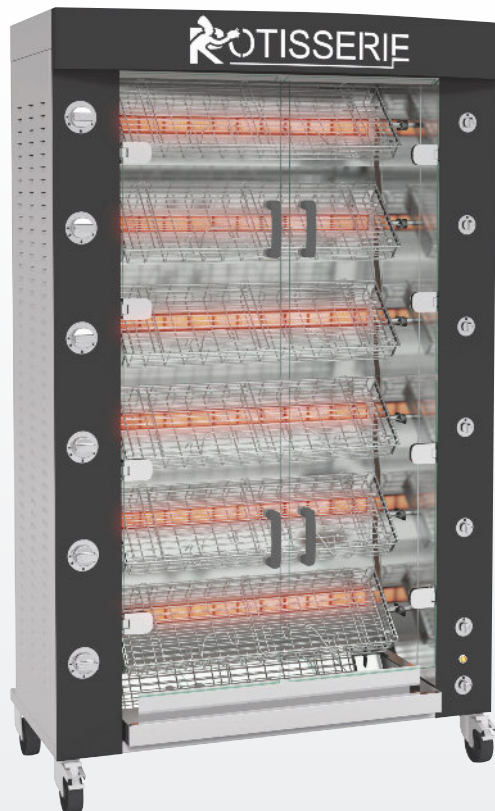

1160.6PAG  
Black enamel



#### TECHNICAL DETAILS

Overview of some of the standard features.

	<p>Replaceable ceramic bricks for significant financial savings</p>		<p>Robust hinges designed for heavy use, with integrated locking in open and closed positions</p>		<p>Gas safety ! separation of the gas and electric chambers avoids any risks of explosion</p>
	<p>Gas and electric switches, in chromed metal</p>		<p>Anti-scald K-glass reduces external thermal radiation (energy saving). Glass overlaps drip pan to keep splatters inside (anti-slip protection).</p>		<p>Removable inside side-panels doubles protection from grease seeping into motors and other sensitive parts</p>

#### ACCESSORIES

A variety of accessories are available. See video of available [accessories](#) and of [vertical spit system](#) online.

<p><b>CUI1160</b> Anti-cutting prongless V-spit.</p>		<p><b>PID1160</b> Tray for unspitting.</p>		<p><b>BRC1160</b> Rectangular basket spit.</p>	
<p><b>BS1160</b> Spit for ham / turkey.</p>		<p><b>BRRO1160</b> Roast-clamp spit.</p>		<p><b>BA1160</b> Lamb/suckling-pig spit.</p>	
<p><b>BCR1160</b> Spatchcock chicken basket.</p>		<p><b>DEC</b> Spit mover.</p>		<p><b>AT</b> Gas lighter.</p>	

### Front view

Rotisserie with roof (optional)  
and base on casters (optional)

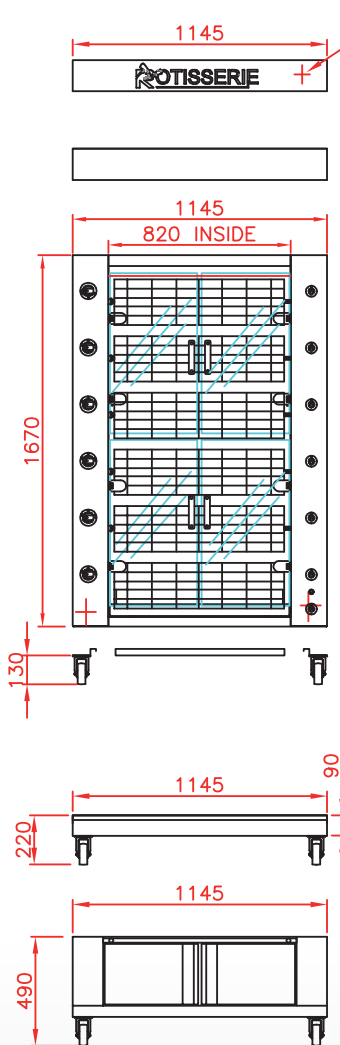

### Side view

Rotisserie with roof (optional)  
and base on casters (optional)

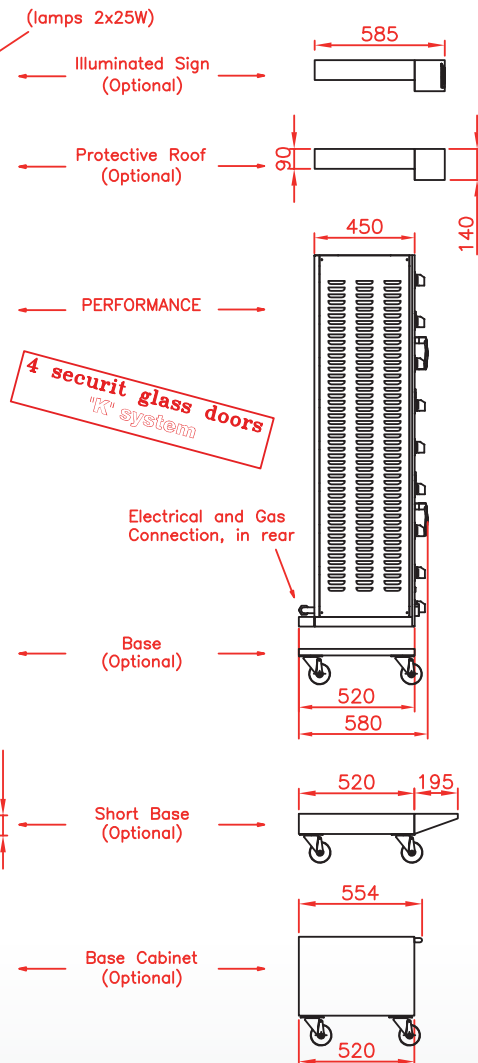

### Top view

Rotisserie with roof (optional)  
and base on casters (optional)

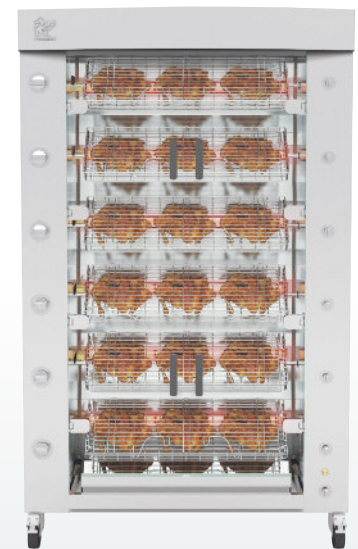
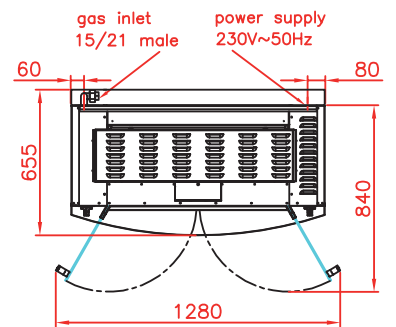

1160.6PAiG  
Stainless steel



Revised :  
December 2016

## SPECIFICATIONS

Capacity	24/30 poultries ; 18/24 open poultries
Gas power	22.5 kW
Power supply	208-230V-50Hz/60Hz
Electrical power	0.53 kW
Weight and size (HxDxW)	160 kg ; 1890 x 655 x 1145 mm
Shipping weight and size	220 kg ; 2000 x 750 x 1210 mm
Guarantee	1 year parts



DISTRIBUTOR / AGENT

Rotisol S.A.S.

Zone industrielle La Trentaine, Avenue Gustave Eiffel  
77507 Chelles cedex - FRANCE

[s.bennell@rotisol.com](mailto:s.bennell@rotisol.com) - Tel : +33 1 64 21 80 00

[www.rotisol.com](http://www.rotisol.com)