



WARNING

Failure to **turn OFF electrical power** prior to installing or removing MotionLights can result in electrical shock, fires, and/or death.

CAUTION: Please read all instructions and warnings before installing!

- Failure to follow these instructions can cause electrical shock, death or permanent injury. Do not work on live electrical outlets. Test outlets to ensure electrical power has been turned OFF.
- MotionLights are for dry location use only. MotionLights are not intended for use on outlets which are fed by more than one branch circuit or for use where one receptacle is switched and the other receptacle is always on.
- Install MotionLights in accordance with all applicable electrical codes and regulations. Only install the corresponding MotionLight style on its intended outlet (duplex and décor).
- MotionLights are designed to be compatible with permanently installed, standard 120V AC duplex and décor outlets with side screw terminals. They will not work with switches or other outlet families. Do not use MotionLights where they could contact bed coverings or other material that could be a fire hazard. Do not use on DC to AC converter systems.
- Power prongs must always fit inside the electrical box. There must be enough room between the sides of the outlet and the electrical box for the power prongs to slide inside the electrical box and around both sides of the outlet. Installing MotionLights without enough room between the outlet and the electrical box can result in damage to the MotionLights, arcing and/or malfunction of your electrical system.
- Do not use MotionLights with electrical boxes containing telephone, data, or TV antenna circuits.
- If you are unsure about any part of these instructions, please consult an electrician.

www.snappower.com



WARNING: Do not work around outlets while the power is on. Do not stick fingers or tools into an electrical box while the power is on.

How SnapPower MotionLights Work

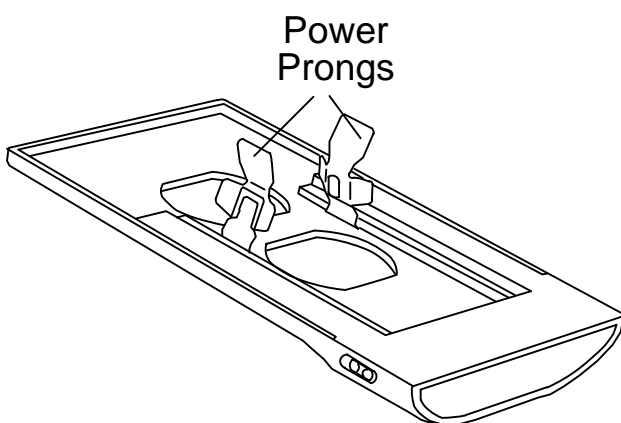

The MotionLight has two power prongs that extend from the back.

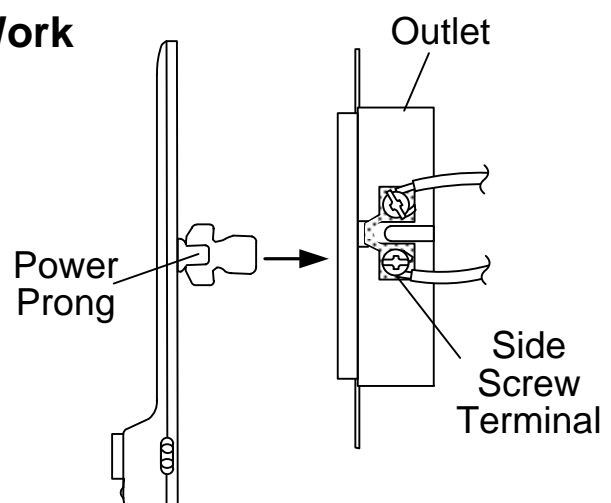

The power prongs slide around the side screw terminals and contact the lower screw heads to extract power for the MotionLight.

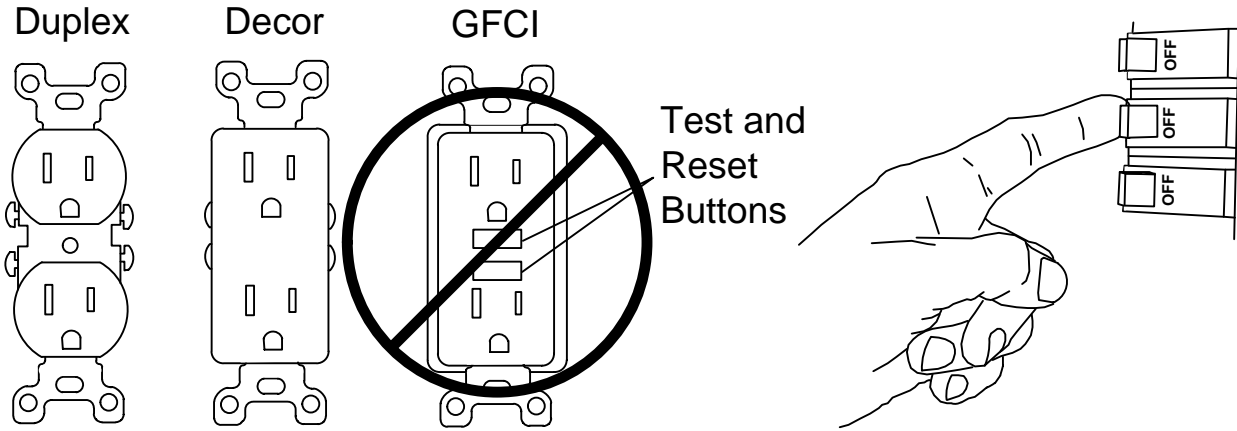

STEP 1: Select an outlet for the MotionLight to be installed over. This MotionLight is only compatible with standard duplex or décor outlets with side screw terminals.

STEP 2: TURN OFF POWER at the circuit breaker and TEST that the power is off at the outlet before removing the existing coverplate or proceeding with the installation.

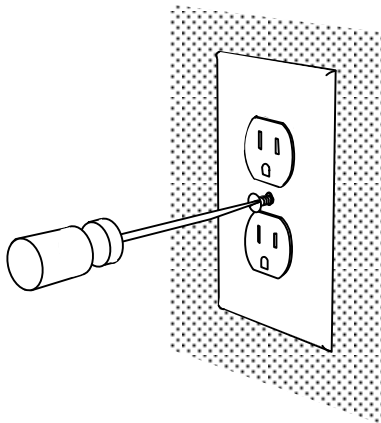

These areas must be clear

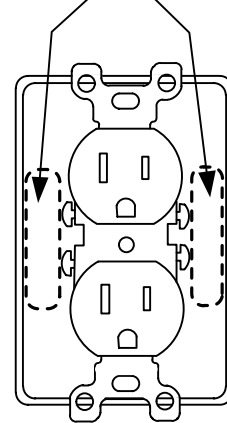

STEP 3: Remove existing coverplate from the outlet.

STEP 4: Look into the box to determine if the areas around the screw terminals are clear so that the prongs can pass into the box and around the outlet. If the area is not clear, see the “Obstructions” section of this manual.

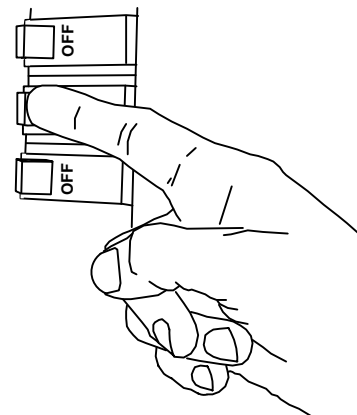
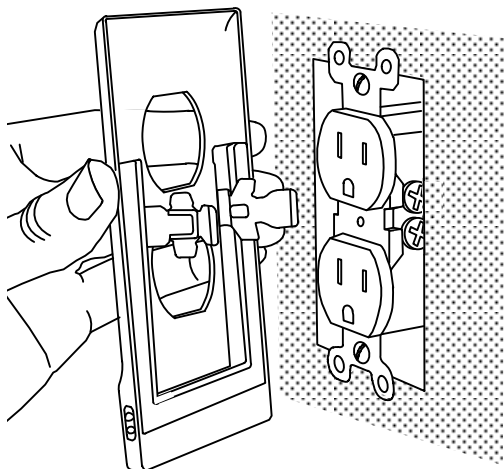

STEP 5: If clear, place the MotionLight over the outlet and secure with screw(s). Be sure that the prongs slide **inside** the electrical box.

STEP 6: Turn ON electrical power to the outlet. Darken the room and move in front of the MotionLight to test for functionality.

STEP 7: Now that your MotionLight is installed, use the switches on the unit to customize the brightness of the LEDs and the length of time the unit stays on.

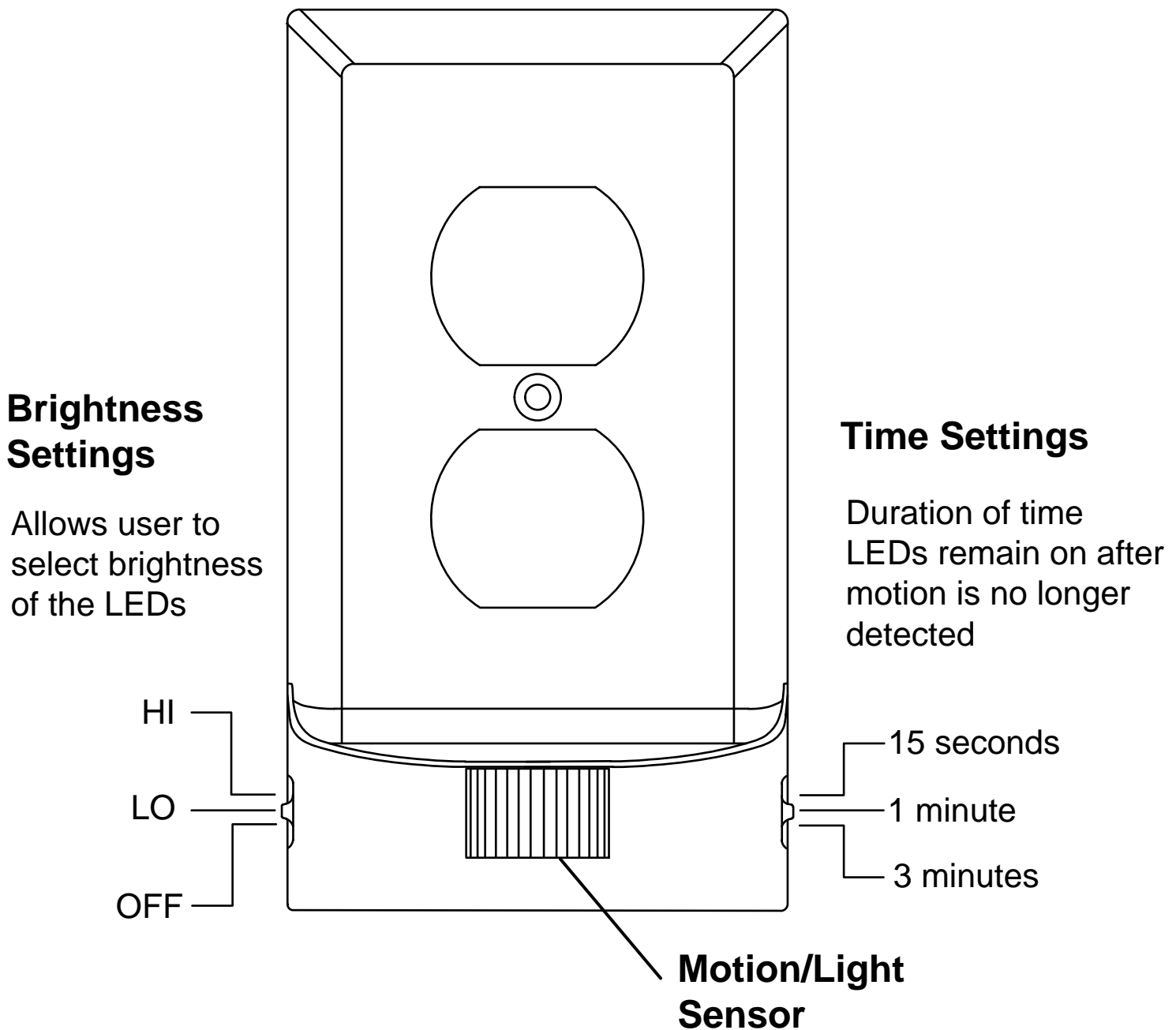

For the latest instructions and trouble shooting information scan this QR code or go to <https://www.snappower.com/pages/ml-instructions.com>



WARNING

Failure to **turn OFF electrical power** prior to installing or removing the MotionLight can result in electrical shock, fires, and/or death.

Having difficulties? Here are some tips that might help. Your MotionLight has been individually tested and worked when it was shipped. It is very unlikely that the MotionLight is malfunctioning. We'll walk you through some of the common issues that you might encounter.

QUICK OVERVIEW OF POSSIBLE INSTALLATION ISSUES

ISSUE	TROUBLESHOOTING STEPS
<p>You can't get the MotionLight installed over the selected outlet.</p>	<p>Is the outlet a standard duplex or décor outlet? If not, please select a different outlet. See the "Non-compatible Outlet" section of the troubleshooting guide.</p>
	<p>Is there an obstruction that is preventing the prongs from passing around the outlet and inside the electrical box? See the "Obstruction" section of the troubleshooting guide.</p>
<p>You have installed the MotionLight over a compatible outlet but it is not illuminating.</p>	<p>Did you turn the power back on?</p>
	<p>The MotionLight only illuminates when the area is dark and motion is detected. You may need to darken the room or place your hand over the light/motion sensor. The light/motion sensor is the rectangle in the lower center of the MotionLight.</p>
	<p>Check to make sure the brightness switch (the switch on the front of the MotionLight) is in the "Low" or "High" position.</p>
	<p>Have you installed the MotionLight in the correct orientation over your outlet? The LEDs should be on the same side as the ground on the outlet. See the "Orientation" section.</p>
<p>Is there something interfering with the contact between the prongs and side screw terminals? See "Obstruction" section. Remember to turn the power off before removing the MotionLight!</p>	

The next several pages show specific examples of non-compatible outlets, obstructions resulting from the way your outlet was installed, and some adjustments you can make. Please be careful when correcting these problems and always remember to turn the power off before working around electrical wiring! Test the outlet to be sure you turned off the correct breaker. **If you are not sure about any part of these instructions, please consult an electrician.**

Non-compatible Outlets

Remember that this MotionLight is designed to fit over **standard** duplex and décor outlets with side screw terminals. These types of outlets represent the vast majority of outlets in North American homes. Below are some examples of nonstandard outlets. This MotionLight will not work with nonstandard outlets. You will need to pick a different outlet for your MotionLight. A list of compatible outlets is available at www.snappower.com/pages/trouble-compatibility.

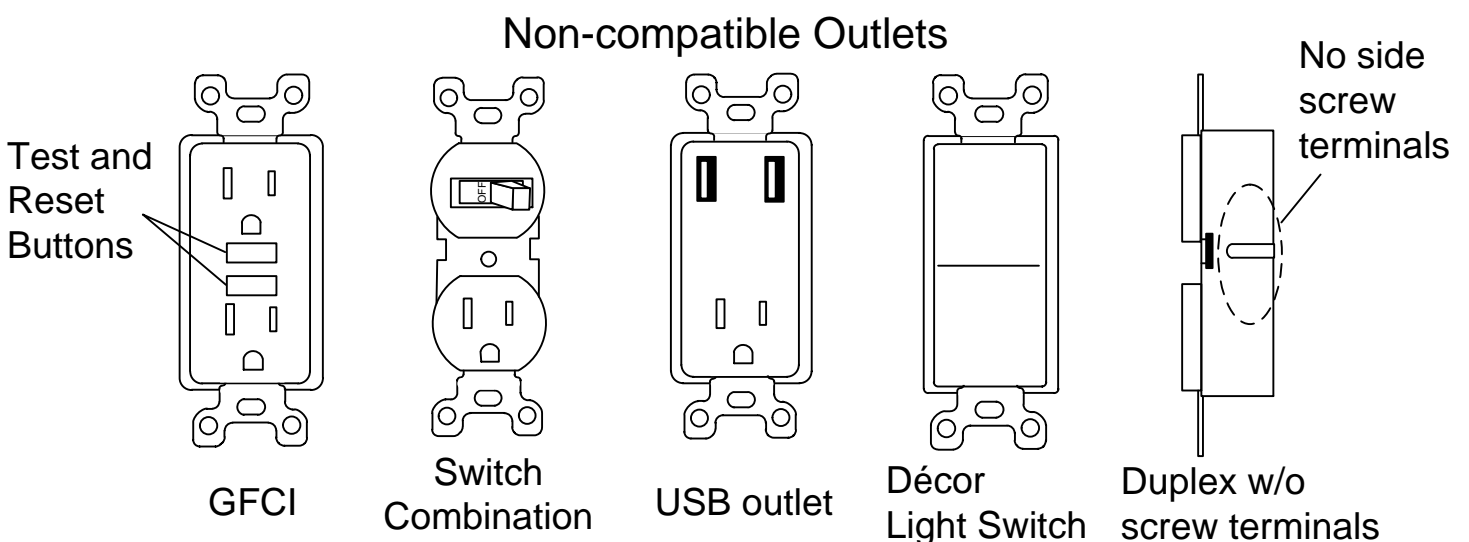

Orientation:

The MotionLight must be installed with the LEDs on the same side as the ground of the outlet. If you install the MotionLight with the LEDs on the same side as the power slots, the MotionLight may not work.

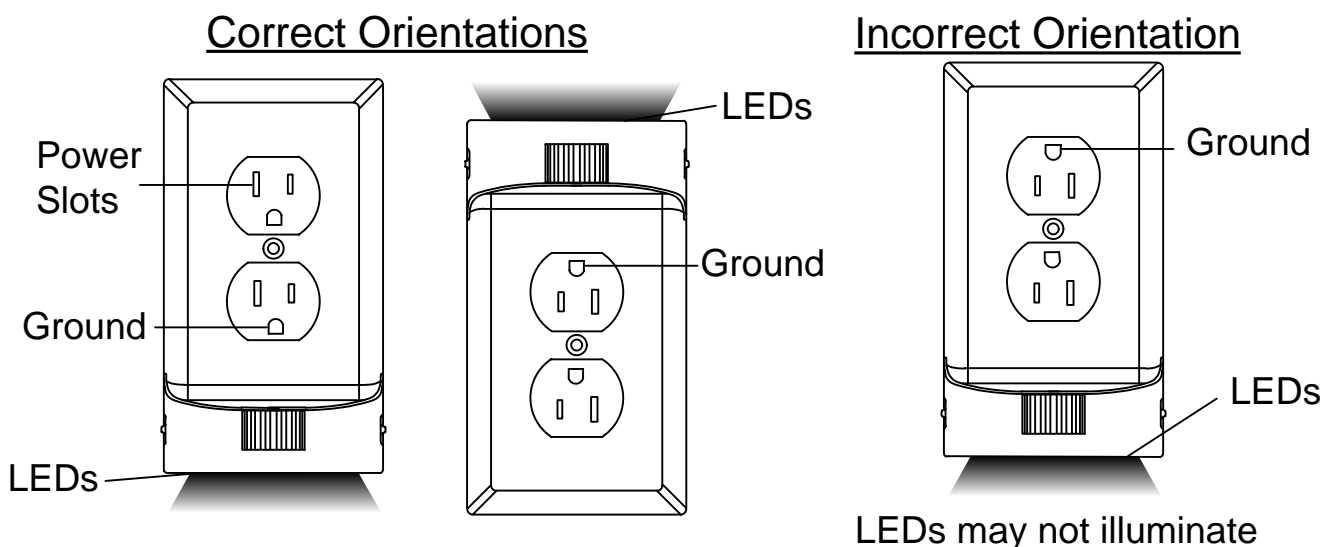

Obstructions

The way your outlet was initially installed could create a number of obstructions that prevent the MotionLight from being installed and/or operating correctly. Be sure to turn off electrical power before working around outlets. If you are unsure about any of these instructions, please consult an electrician.

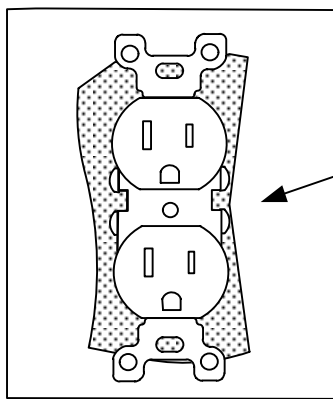

Sheet Rock

Obstruction 1: Sheet rock or other wall coverings can prevent the prongs from passing around the outlet. This can be solved by removing the excess sheet rock near the screw terminals. If you are unsure of how to properly do this, please consult an electrician.

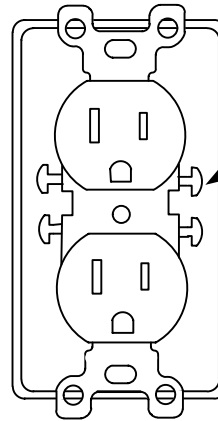

Extended Screws

Obstruction 2: Screws may be all the way out and catch the ends of the prongs. To solve this, simply maneuver the prongs around the screws during installation.

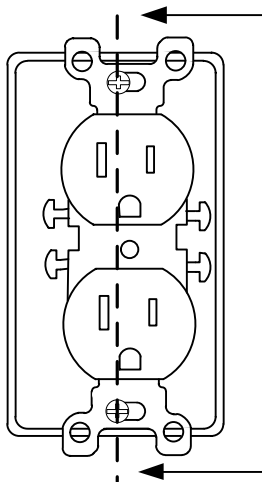

Obstruction 3: Outlet not centered
If your outlet is not centered, there might not be room to insert the prongs on one side. If this is the case, your outlet will need to be centered. If you are unsure of how to do this, please consult an electrician.

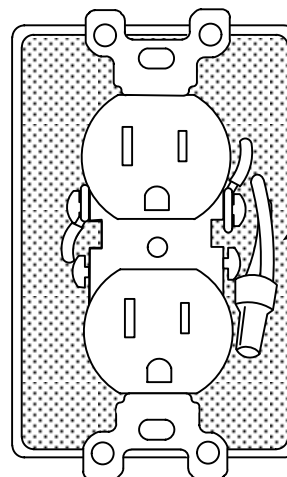

These wires may prevent the Product prong from contacting the screw terminal

Obstruction 4: Wires in the way
In order for the prongs to fit around the outlet the areas next to the screw terminals need to be free from obstructions. If there are wires blocking the side screw terminals, they will need to be moved. If you are unsure of how to do this, or if you see bare wires next to the screw terminals, please consult an electrician.

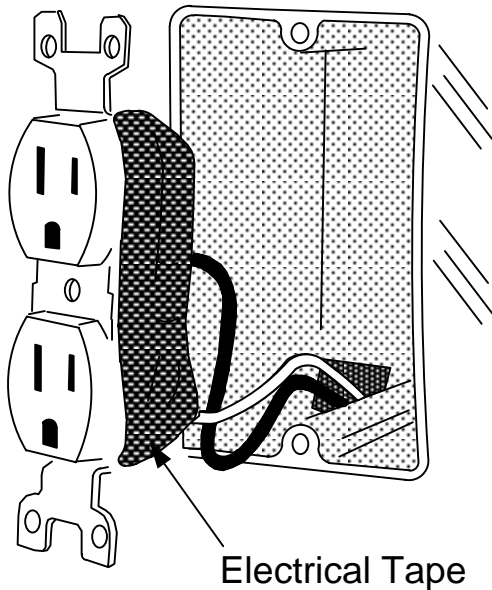

Electrical Tape

Obstruction 5: Electrical Tape

If electrical tape is wrapped around your outlet it will prevent the prongs from contacting the side screw terminals. This tape will need to be removed in order for the MotionLight to work. If you are unsure of how to do this, please consult an electrician.

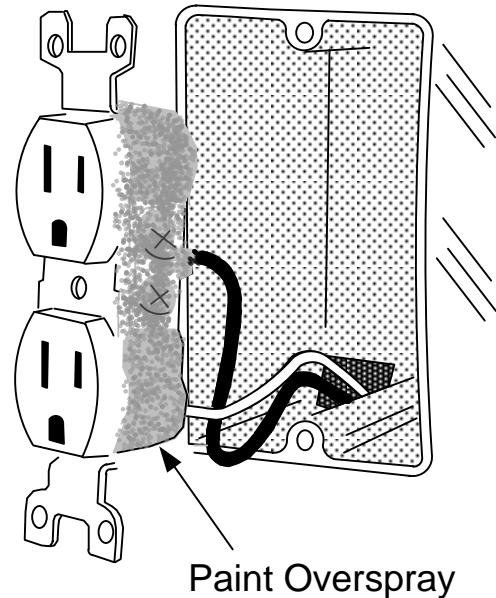

Paint Overspray

Obstruction 6: Paint

Paint overspray can coat the sides of the outlet and prevent the prongs from making electrical contact with the screw terminals. This paint may need to be removed from the screw terminals for the MotionLight to work. If you are unsure of how to do this, please consult an electrician.

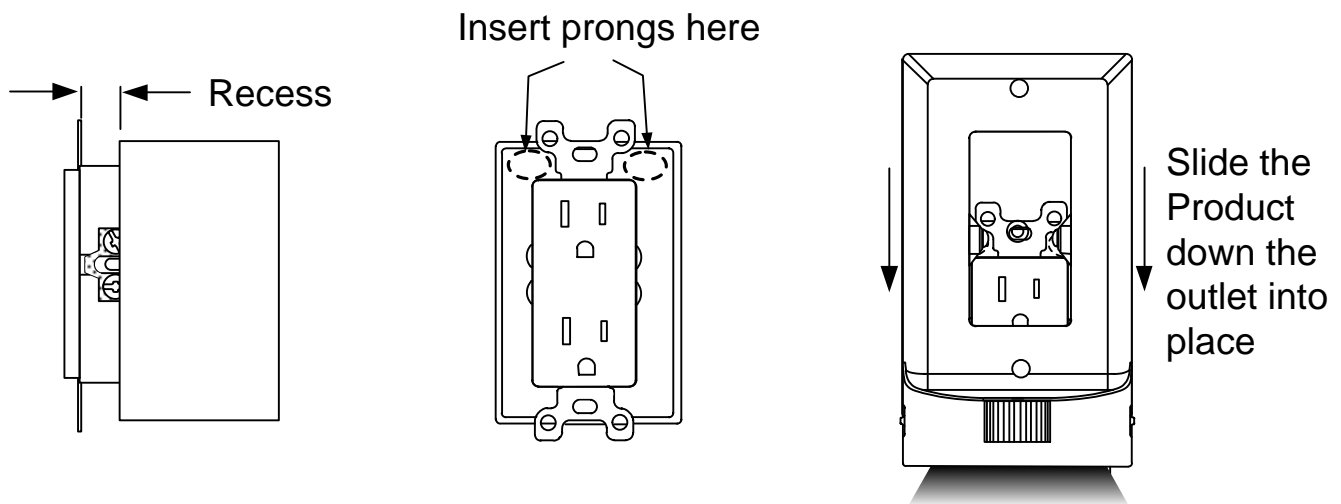

Obstruction 7: Recessed or narrow electrical box

Outlets are designed to be mounted inside an electrical box. In some situations, thick wall coverings (tile, paneling, etc) move the outlet forward and out of the box. The prongs may pass around the outlet and get caught on the recessed electrical box or go outside of the electrical box altogether. This can also occur with narrow electrical boxes. When prongs go outside of a metal electrical box, arcing between the screw terminals and metal box can occur. This can be solved by careful installation to ensure that the prongs are inserted inside the box.

For outlets with recessed boxes, try initially inserting the prongs into the electrical box at the upper or lower yoke of the outlet, pushing the prongs into the electrical box and then sliding the MotionLight into place (see drawings above). For a video showing this installation, see our online troubleshooting videos at www.snappower.com. If you are unsure about any of the instructions, please consult an electrician.

SNAPPOWER MOTIONLIGHT LIMITED ONE-YEAR WARRANTY



SnapPower warrants that the MotionLight accompanied by this limited warranty is free from manufacturing defects in materials and workmanship for a period of one (1) year from the original purchase. For more information about the warranty and limitations it includes go to: www.snappower.com/pages/warranty or scan the QR code.