



# VACUUM SEALER SE-310

Tabletop model. 10 m<sup>3</sup>/h. 320 mm.



- ✓ Safety system with protection against vacuum failure.
- ✓ NSF-listed model.

## INCLUDES

- ✓ Sensor Controls
- ✓ Up to 10 seconds of extra vacuum pull
- ✓ Soft air function
- ✓ Dry oil cycle
- ✓ BUSCH pump
- ✓ NSF Approved
- ✓ Clear methacrylate lid
- ✓ Filling plate

## ACCESSORIES

- Filling plates
- Liquid insert plates
- Vac-norm external vacuum kits
- Vac-norm containers
- Smooth bags for vacuum packing

## SALES DESCRIPTION

320 mm. sealing bar.  
 10 m<sup>3</sup>/h Busch vacuum pump.  
 Vacuum controlled by sensor.

- ✓ Powered by Busch.
- ✓ Vacuum controlled by sensor.
- ✓ Vacuum PLUS.
- ✓ Digital keyboard.
- ✓ Control panel equipped with display indicating the exact vacuum percentage.
- ✓ "Pause" button to marinate food.
- ✓ Safe liquid packing thanks to sensor control.
- ✓ Double seal.
- ✓ Cordless sealing bar.
- ✓ Bag-sealing programme.
- ✓ Pulse-controlled decompression.
- ✓ Vac-Norm ready with Automatic decompression.
- ✓ Stainless steel body and chamber. Deep-drawn chamber.
- ✓ Damped transparent lid of highly durable polycarbonate.
- ✓ Dry-oil programme for drying the pump.
- ✓ Working hours counter for oil changes.



**sammic** | [www.sammic.us](http://www.sammic.us)  
 Food Service Equipment Manufacturer

[usa@sammic.com](mailto:usa@sammic.com) phone +1 (224) 307-2232  
 1225 Hartrey Avenue toll free +1 844 275 3848  
 60202-1056 Evanston, IL



Project	Date
Item	Qty
Approved	

FOOD PRESERVATION AND SOUS-VIDE  
 VACUUM PACKING MACHINES - "SENSOR" LINE

product sheet  
 updated 11/17/20



# VACUUM SEALER SE-310

Tabletop model. 10 m<sup>3</sup>/h. 320 mm.



## SPECIFICATIONS

Pump capacity: 350 cf/h  
 Bar length: 13 "  
 Total loading: 0.5 Hp  
 Vacuum pressure (maximum): 2 mbar

### Internal dimensions

- ✓ Width: 13 "
- ✓ Depth: 14 "
- ✓ Height: 6.1 "

### External dimensions (WxDxH)

- ✓ Width: 15 "
- ✓ Depth: 18.3 "
- ✓ Height: 16 "

Net weight: 87.7 lbs.

Noise level (1m.): 75 dB(A)  
 Background noise: 32 dB(A)

### Crated dimensions

18.1 x 20.9 x 18.1 "  
 Gross weight: 97.7 lbs.

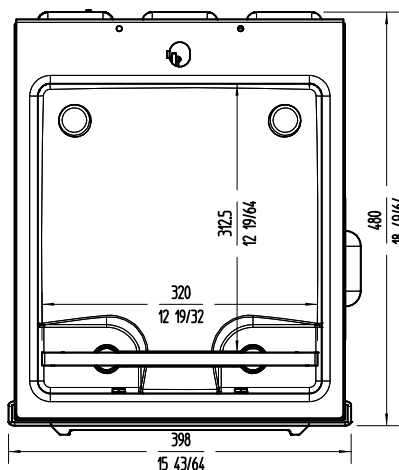
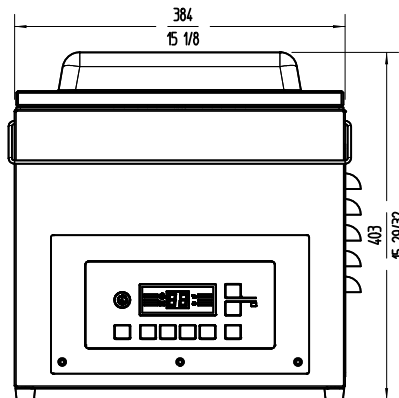
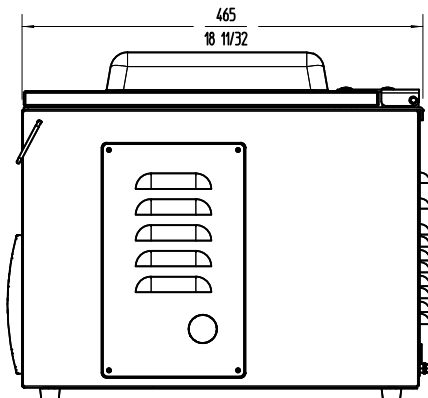

## AVAILABLE MODELS

1140629 Vacuum packing machine SE-310 120/50-60/1

\* Ask for special versions availability

<b>sammic</b>   www.sammic.us <b>Food Service Equipment Manufacturer</b> usa@sammic.com phone +1 (224) 307-2232 1225 Hartrey Avenue toll free +1 844 275 3848 60202-1056 Evanston, IL		Project	Date
		Item	Qty
		Approved	

FOOD PRESERVATION AND SOUS-VIDE  
 VACUUM PACKING MACHINES - "SENSOR" LINE

product sheet  
 updated 11/17/20