



IMMERSION CIRCULATOR SMARTVIDE 5

1.6 Hp / 1200 W. Maximum capacity: 30 lt./ 8 gal.



temperature technique.

- ✓ Increases **profits** due to lack of product shrink.
- ✓ Requires **very little hands-on time**, allowing the Chef to do other tasks while the product is being cooked. Just program temperature and time, SmartVide will do the rest. 4 buttons and a full-color TFT display that offers **all the information at a glance** makes operation a child's play.
- ✓ SmartVide5 is **portable**: thanks to their ergonomic handle, SmartVide5 can be taken from a container to another easily. Additionally, the optional bag allows easy transport - wherever the Chef goes.
- ✓ **HACCP-ready**: thanks to Bluetooth connectivity, it is possible to export or print cooking results at the end of each cycle.
- ✓ **Your appliance, always updated**: free firmware update, no matter where the appliance is.

ACCESSORIES

- Needle Probe for sous-vide cookers
- Lid for SmartVide
- Probe Foam Seal
- Floating balls for SmartVide
- Insulated tank for SmartVide immersion circulator
- SmartVide transport bag
- Smooth bags for sous-vide cooking

SALES DESCRIPTION

Commercial high-precision sous-vide cooker. Reliable, user-friendly, portable. Interchangeable between °C and °F.

- ✓ Bluetooth connectivity.
- ✓ HACCP-ready.
- ✓ Optional core probe.
- ✓ Firmware update.

Portable precision cooker with stirrer for up to 30 lt. / 8 gal. containers. Designed for chefs, developed with chefs.

- ✓ The thick stainless steel, robust construction guarantees commercial performance. The front panel and the grip are made of fiberglass-reinforced polyamide.
- ✓ SmartVide guarantees cooking at a **precisely controlled temperature** while preserving the quality of the product, enhancing flavor and texture. Equipped with a highly precise temperature control system to obtain extremely consistent results.
- ✓ Allows cooking food in their own juice and using this juice immediately after cooking to **enhance flavors**.
- ✓ Marinates and macerates an ingredient in **half the time**.
- ✓ **Infuses and flavors** oil, fat or other products applying the controlled



sammic | www.sammic.us
Food Service Equipment Manufacturer

usa@sammic.com
1225 Hartrey Avenue
60202-1056 Evanston, IL

phone +1 (224) 307-2232
toll free +1 844 275 3848



Project	Date
Item	Qty
Approved	

product sheet
updated 11/25/20

FOOD PRESERVATION AND SOUS-VIDE
SOUS-VIDE COOKERS



IMMERSION CIRCULATOR SMARTVIDE 5

1.6 Hp / 1200 W. Maximum capacity: 30 lt./ 8 gal.



SPECIFICATIONS

Temperature

Display precision: 0.1 °F
 Range: 41 °F - 203 °F
 Permissible ambient temperature: 41 °F - 104 °F

Time

Resolution: 1 '
 Cycle duration: 1' - 99 h

General features

Maximum recipient capacity: 8 gal.
 Total loading: 1.6 Hp (120V) / 2.1 Hp (208V)
 Submersible part dimensions: 4.6 " x 3.7 " x 5.8 "
 External dimensions (WxDxH): 4.6 " x 5 " x 13 "

Net weight: 6.8 lbs.

Crated dimensions

16.1 x 7.3 x 11.2 "
 Gross weight: 11.0 lbs.

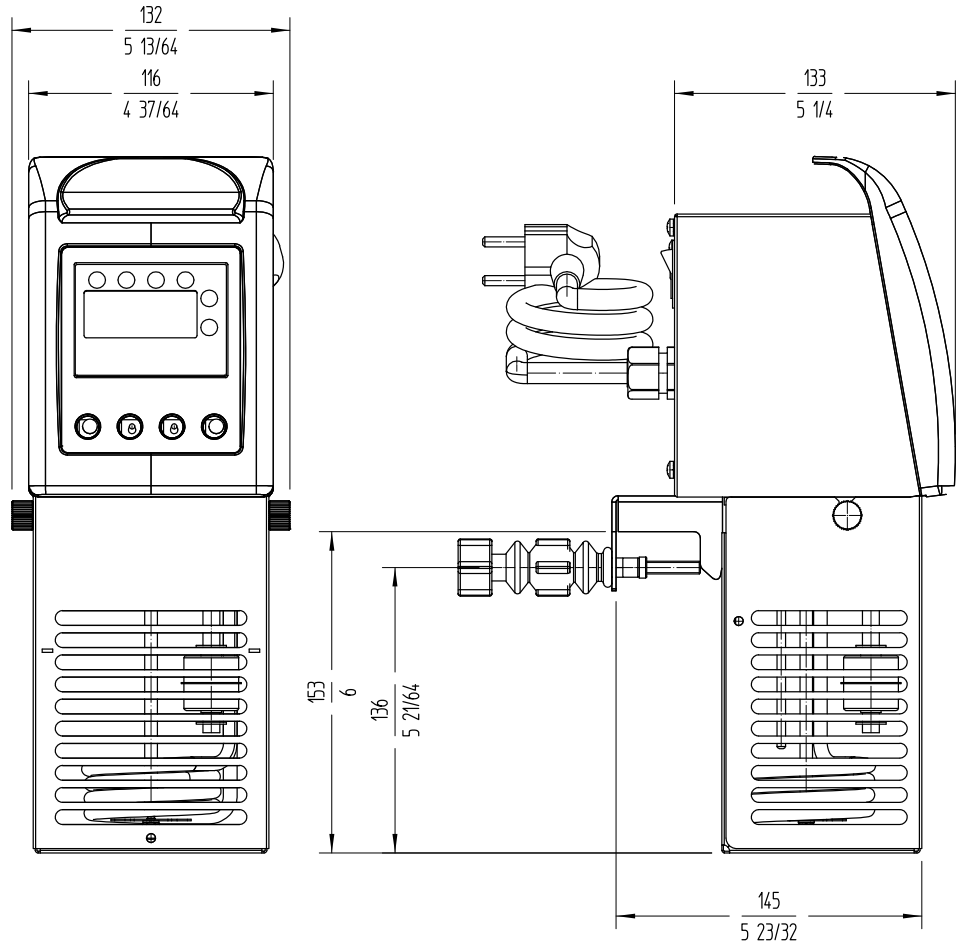

AVAILABLE MODELS

1180101 SmartVide 5 230/50-60/1 UK

1180103 SmartVide 5 120/60/1

* Ask for special versions availability

sammic | www.sammic.us
 Food Service Equipment Manufacturer

usa@sammic.com phone +1 (224) 307-2232
 1225 Hartrey Avenue toll free +1 844 275 3848
 60202-1056 Evanston, IL



Project	Date
Item	Qty
Approved	

FOOD PRESERVATION AND SOUS-VIDE
SOUS-VIDE COOKERS

product sheet
updated 11/25/20