



FS0822 - 800lb Flake Ice Machine

Prodigy Plus® Flake Ice Machine



Features & Benefits

- Sealed, maintenance-free bearings for reduced preventative maintenance and long-lasting performance
- Stainless steel evaporator and auger for maximum durability
- AutoAlert™ indicator lights for better visibility
- Operational footprint among the industry's smallest
- Unit specific QR code for quick access to service manuals, cleaning guides and warranty history
- Front-breathing - No side clearance required for flexible placement
- Smart-Board™ advanced feature module available for additional diagnostic capabilities
- Optional Vari-Smart™ ice level control allows operators to customize ice levels
- Antimicrobial protection guards internal surfaces between cleanings
- A full range of water- and energy-saving features



Sealed, maintenance-free bearings ensure maximum reliability and contribute to a long machine life



24 Hour Volume Production

Air Cooled		Remote Cooled			Water Cooled			
70°F/21°C 50°F/10°C	Air Water	90°F/32°C 70°F/21°C	70°F/21°C 50°F/10°C	Air Water	90°F/32°C 70°F/21°C	70°F/21°C 50°F/10°C	Air Water	90°F/32°C 70°F/21°C
800/363 lb/kg		606/275 lb/kg	760/345 lb/kg		589/267 lb/kg	775/352 lb/kg		581/264 lb/kg



Modular Bin Options

Model Number*	Dimensions W" x D" x H"	Bin Application		Ship Weight lb/kg
		Capacity lb/kg	Finish	
B322S	22 x 34 x 44**	370/168	Metallic	140/64
B330P	30 x 34 x 31**	344/156	Poly	90/41
B530P	30 x 34 x 44**	536/244	Poly	110/50
B530S	30 x 34 x 44**	536/244	Metallic	150/68
B842S	42 x 34 x 44**	778/353	Metallic	190/86
B948S	48 x 34 x 44**	893/406	Metallic	209/95

* Contact Scotsman for bin top requirements. ** Add 6" Height for bin legs.



AutoAlert™ indicator lights and QR code for easy maintenance



Flake Ice



Cools more quickly than other ice forms. Ideal for seafood and produce displays.



Certification



Warranty

- 3 years parts and labor on all components.
- 5 years parts on the compressor.
- Warranty valid in North, South & Central America for commercial installations.
- Contact factory for warranty in other regions.
- Residential Applications: 1 year parts and labor



FS0822 - 800lb Flake Ice Machine

Prodigy Plus® Flake Ice Machine

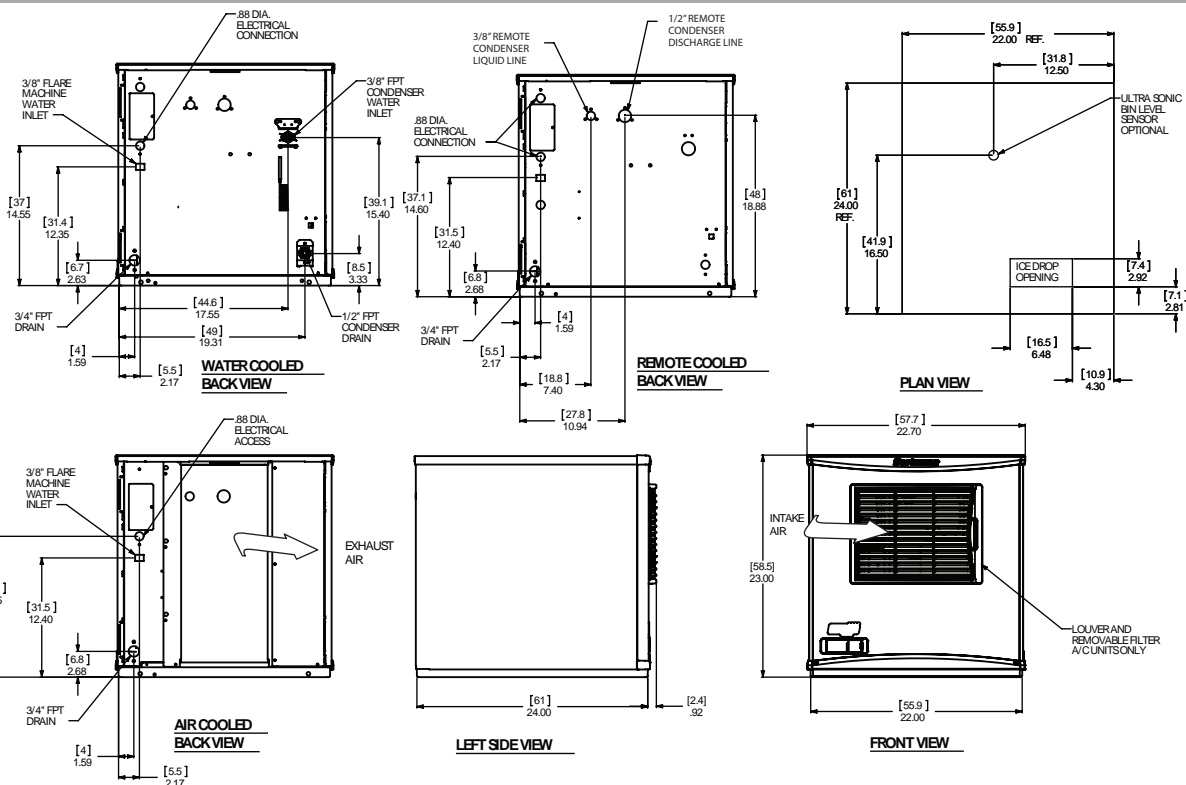

Specifications

Model Number	Condenser Unit	Basic Electrical Volts/Hz/Phase	Max. Fuse Size or HACR Circuit Breaker (amps)	Circuit Wires	Min. Circuit Ampacity	Energy Consumption kWh/100 lb (45.4 kg) 90°F(32°C)/70°F(21°C)	Water Usage Gallons/100 lb (liters/45.4 kg)	
							Potable 90°F(32°C)/70°F(21°C)	Condenser 90°F(32°C)/70°F(21°C)
FS0822A-1	Air	115/60/1	25	2	18.3	5.68	12.0/45.5	-
FS0822R-1	Remote	115/60/1	25	2	19.4	5.8	12.0/45.5	-
FS0822W-1	Water	115/60/1	25	2	16.7	4.72	12.0/45.5	120/454.8
FS0822W-32	Water	208-230/60/1	15	2	8.9	4.72	12.0/45.5	120/454.8



All Models

Dimensions (W x D x H):

Unit: 22" x 24" x 23"
(55.9 x 61.0 x 58.4 cm)

Shipping Carton: 25.5" x 27.5" x 28.5"
(64.8 x 69.9 x 72.4 cm)

Shipping Weight: 175 lb / 79 kg BTUs per hour: 7,100

Refrigerant: R-404A



Accessories

Model Number	Description
KVS	Vari-Smart™ Ice Level Control - Program ice bin levels to match ice needs.
KSBU	Smart-Board™ Advanced Control - Use additional operational data for fast diagnosis.
KSBU-N	Smart-Board™ Advanced Control with Network - Network capable.
ERC111-1	Remote condenser for F0822R, 115/60/1 - Consult remote condenser spec sheet for details.
BRTE10	10ft (3.0 m) line set, brazing required
BRTE25	25ft (7.6 m) line set, brazing required
BRTE40	40ft (12.2 m) line set, brazing required
BRTE75	75ft (22.9 m) line set, brazing required
KPAS	Prodigy Advanced Sustainability Kit - Includes KVS and KSBU - N

Scotsman recommends all ice machines have water filtration. See Scotsman water filter specification sheet for details.



Operating Requirements

	Minimum	Maximum
Air Temperatures	50°F (10°C)	100°F (38°C)
Water Temperatures	40°F (4.4°C)	100°F (38°C)
Remote Cond. Temps	-20°F (-29°C)	120°F (49°C)
Water Pressures	20 PSIG (1.4 bar)	80 PSIG (5.5 bar)
Electrical Voltage	-5%	+10%

Specifications and design are subject to change without notice.

FS0822 - 800lb Flake Ice Machine