

PLAN

SCALE: 1/2"=1'-0"

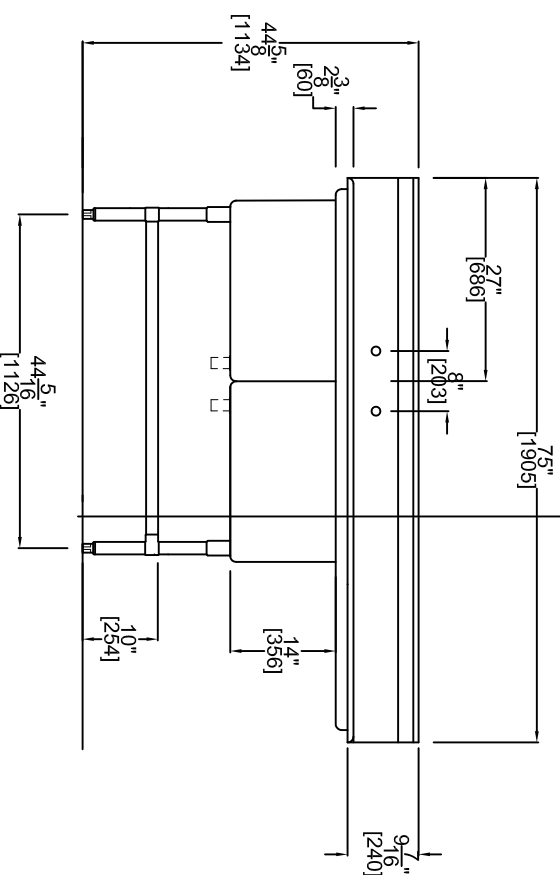
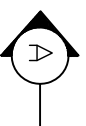

ELEVATION

SCALE: 1/2"=1'-0"

CONSTRUCTION OF 2 COMPT. SINK c/w DB. RIGTH SIDE.

MODEL: MA-S2424-2-R24

CONSTRUCTED: 18ga. S.STEEL 304 FINISH

1 5/8" dia. LEGS and BRACES 16ga. GALVANIZED

c/w ADJUSTABLE BULLET FEET

SINKS: 24"x24"x14" dp. ALL COVERED CORNERS

SINK SLOPE TO 2" dia. CORNER DRAINS.

DRAINS c/w REMOVABLE STOPPERS.

REAR SPLASH TO ACCOMODATE 8" c/c TYPICAL FAUCET

DRAINBOARD SLOPE TOWARDS THE SINK

1 1/2" dia. EXTERIOR DRAIN (TYPICAL NORTH AMERICAN)

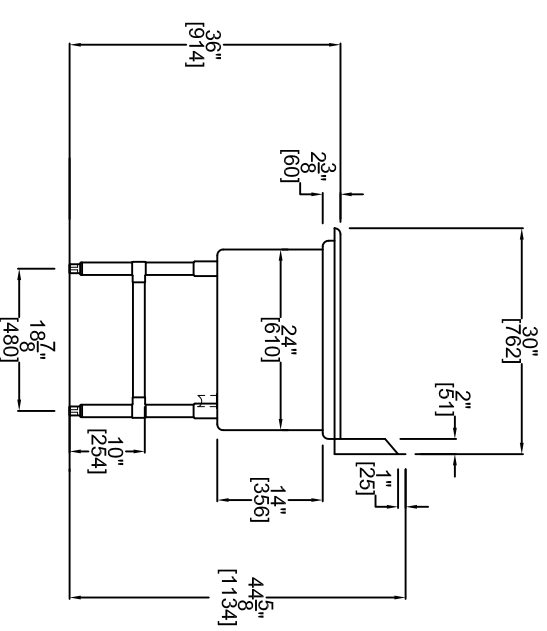

SECTION A

SCALE: 1/2"=1'-0"

MODEL
MA-S2424-2-R24

REVISION:



880 Milner Avenue
Toronto, Ontario, Canada
M1B 5N7
416 321-5823
Toll Free: 1 (866) 722-2649
www.rabcofoodservice.com

PROJECT NAME:

VARIES

DATE:

NOV. 24, 2017

MODEL:

MA-S2424-2-R24

REVISION:

PAGE:

1 of 1

SHEET No.:

1

SCALE:

1/2"=1'-0"

ITEM DESCRIPTION:

2 COMPT. SINK DB/R